

Joseph Lstiburek, Ph.D., P.Eng, ASHRAE Fellow

# Building Science

Adventures In Building Science

presented by [www.buildingscience.com](http://www.buildingscience.com)

## Definition of a Problem

People  
Pollutant (hot, wet, UV, ozone)  
Path  
Pressure

Building Science Corporation

Joseph Lstiburek 2

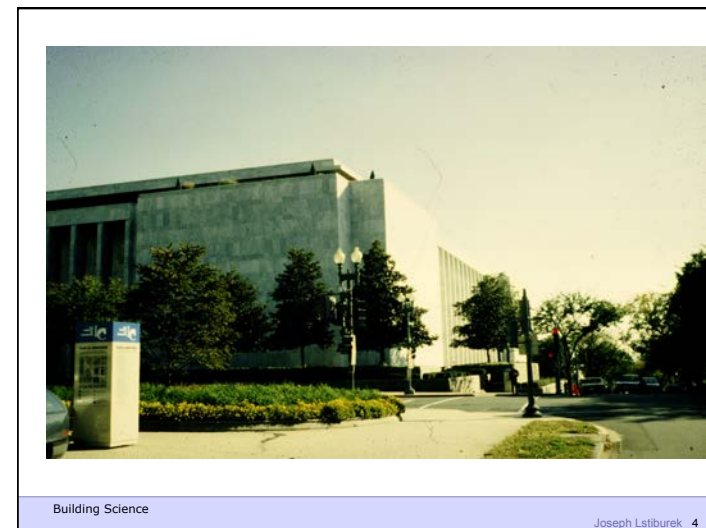
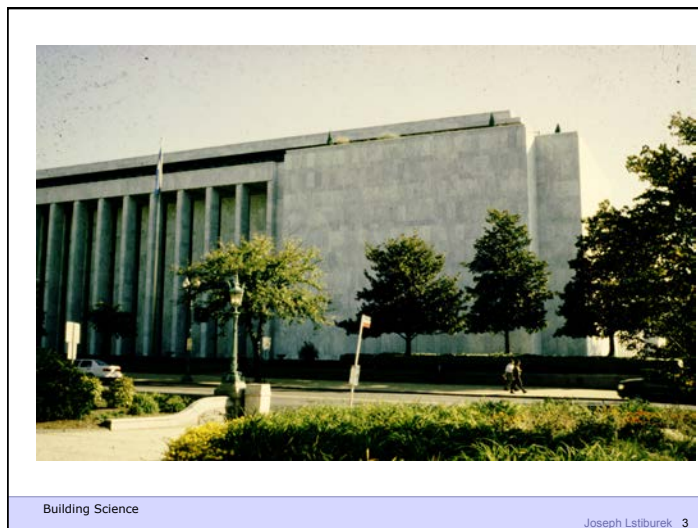

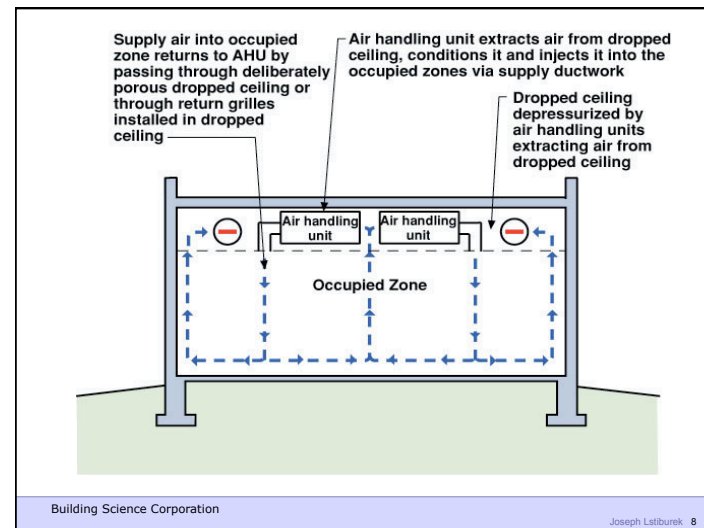
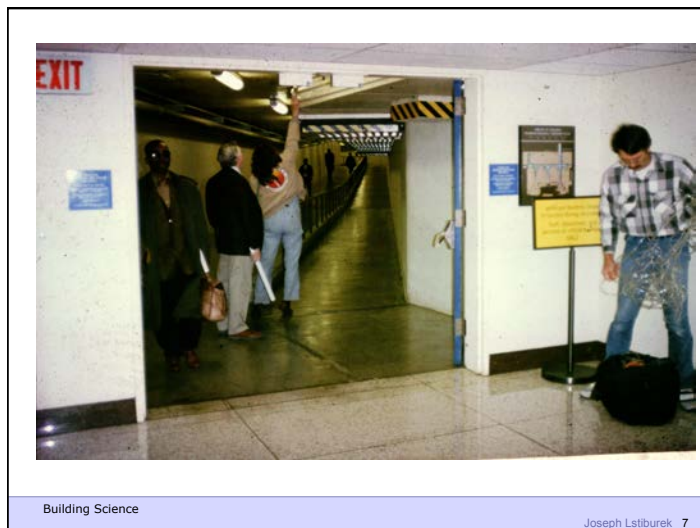
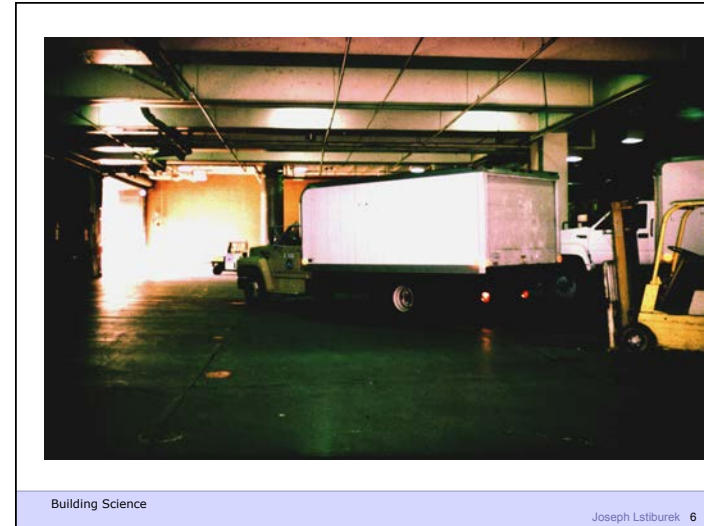
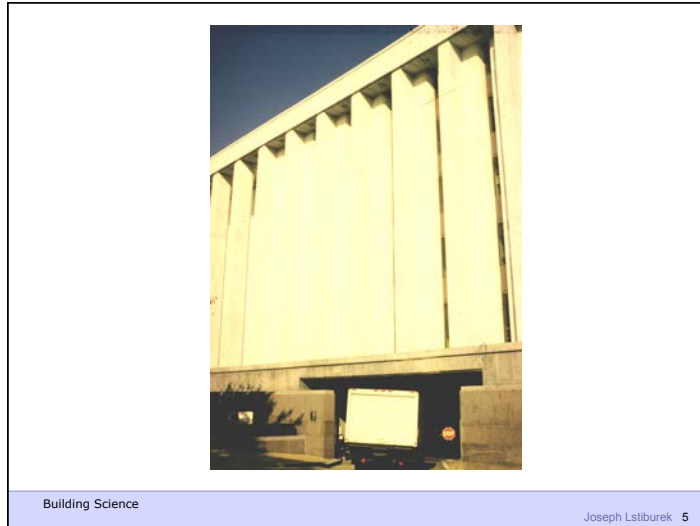

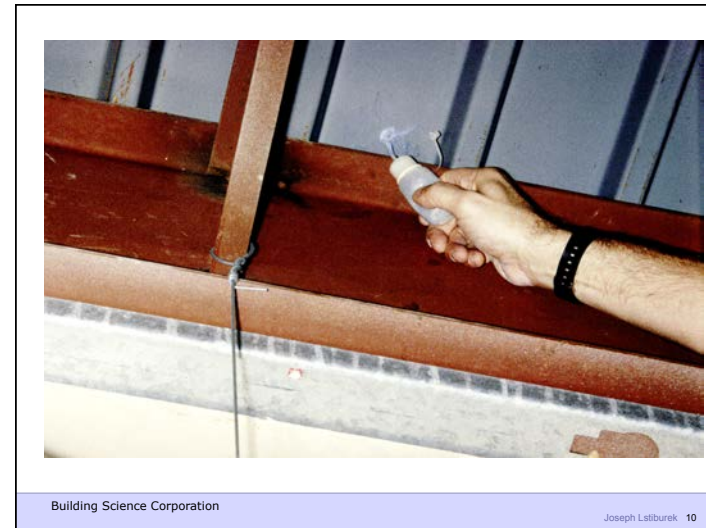
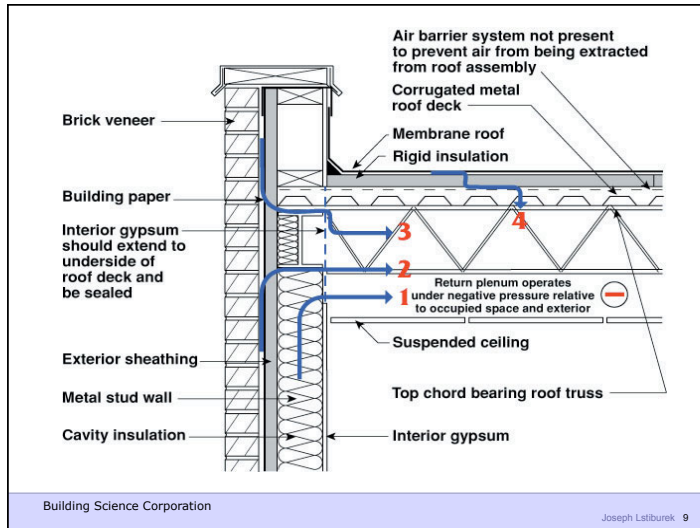

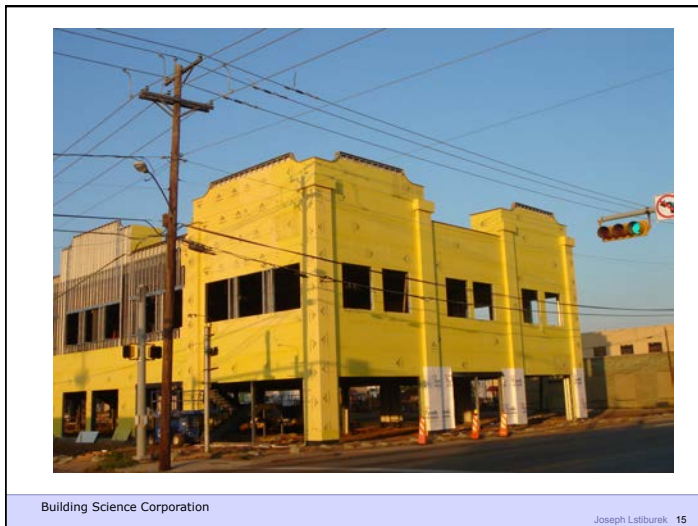
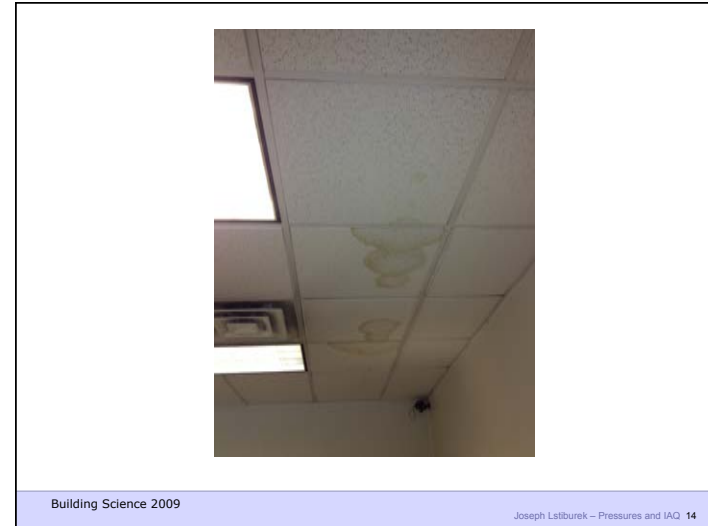

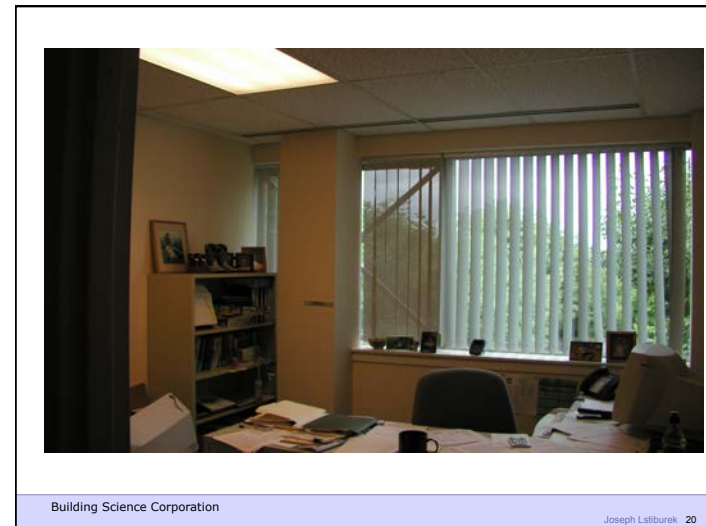
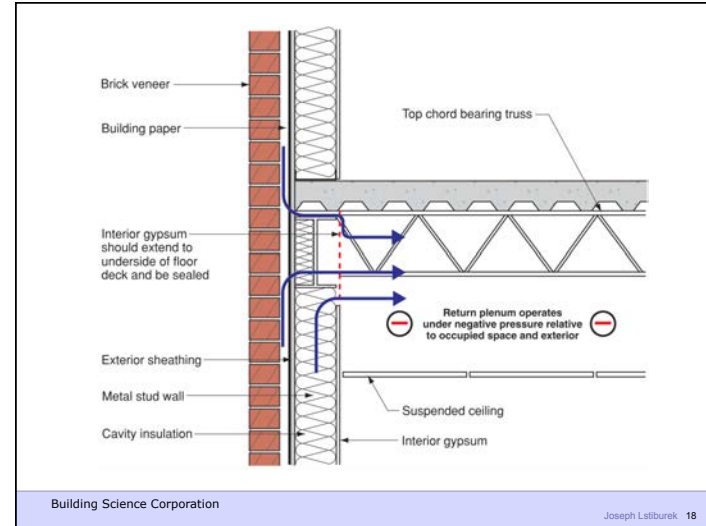
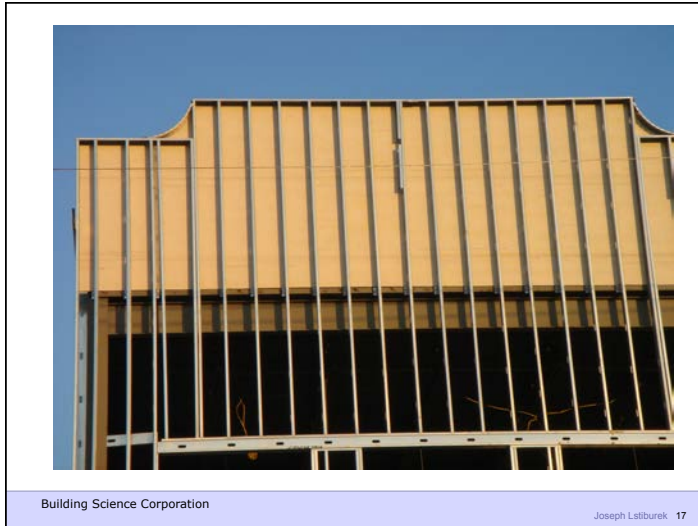

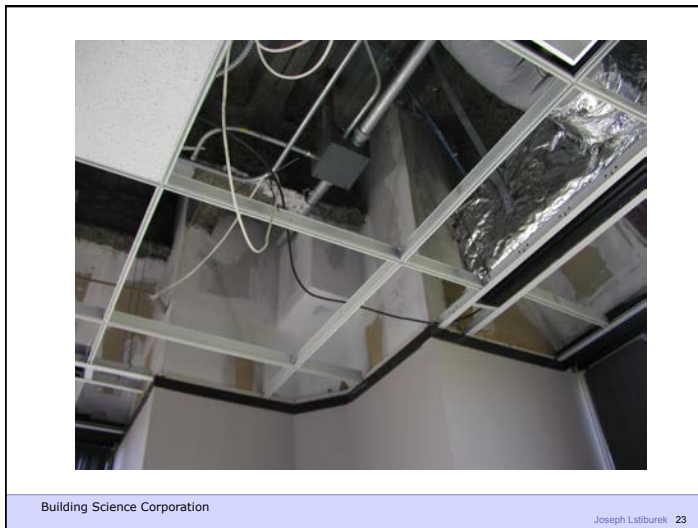
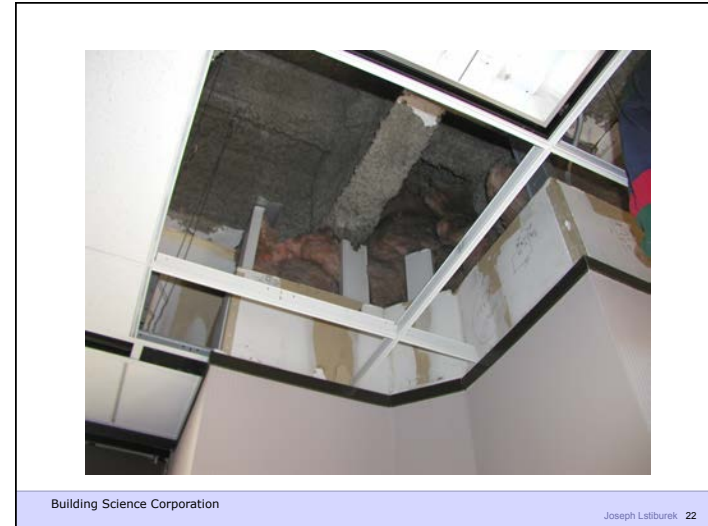



Building Science Corporation

Joseph Lstiburek 25

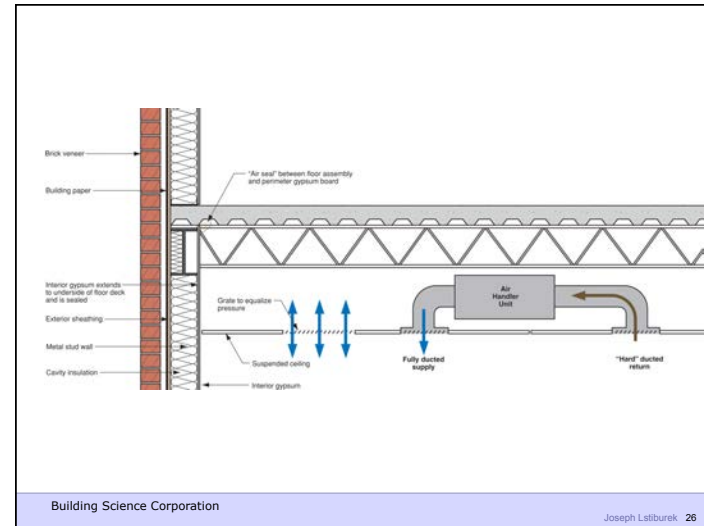

Building Science Corporation

Joseph Lstiburek 26

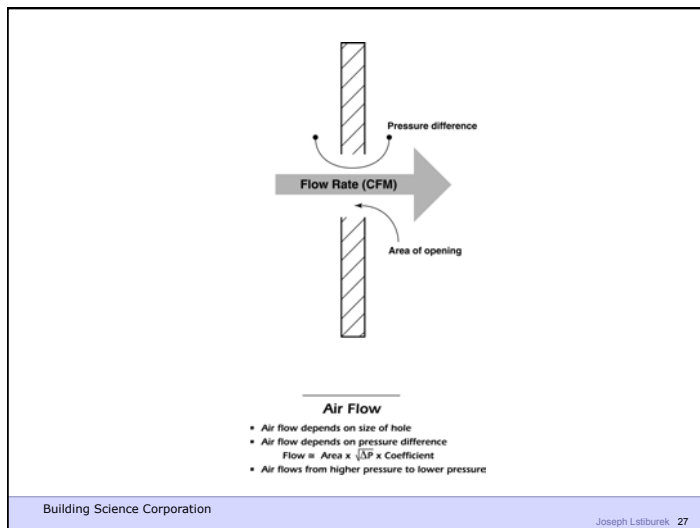

Building Science Corporation

Joseph Lstiburek 27

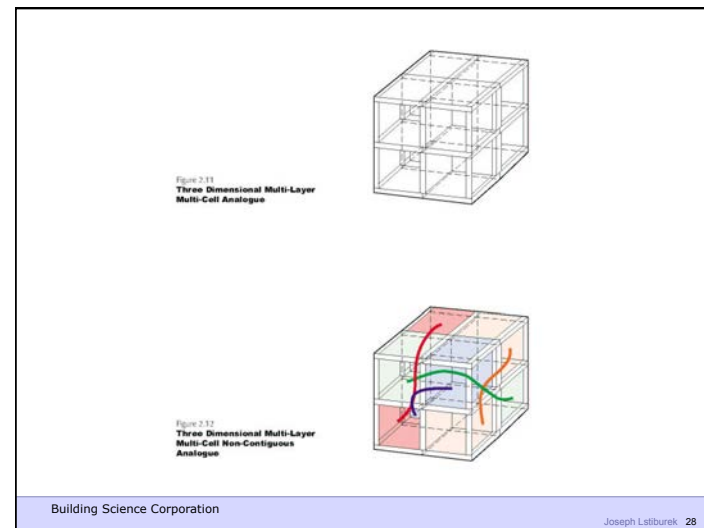

Building Science Corporation

Joseph Lstiburek 28

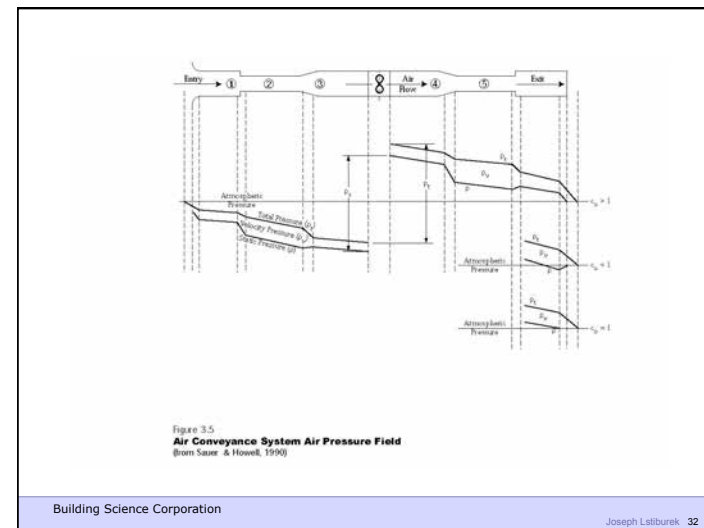
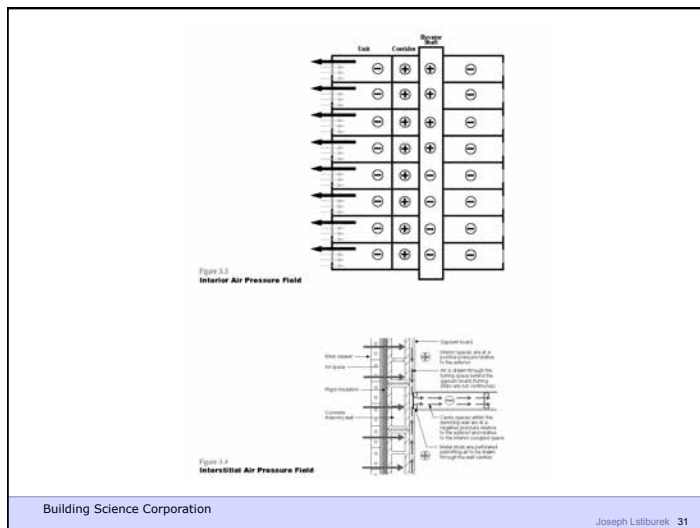
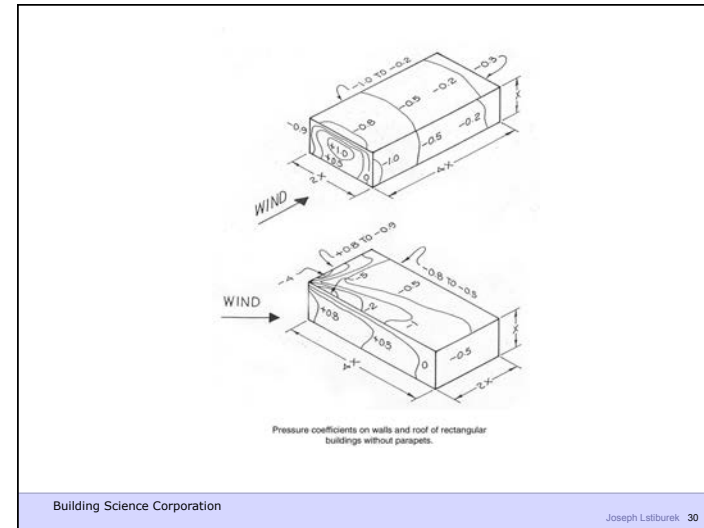
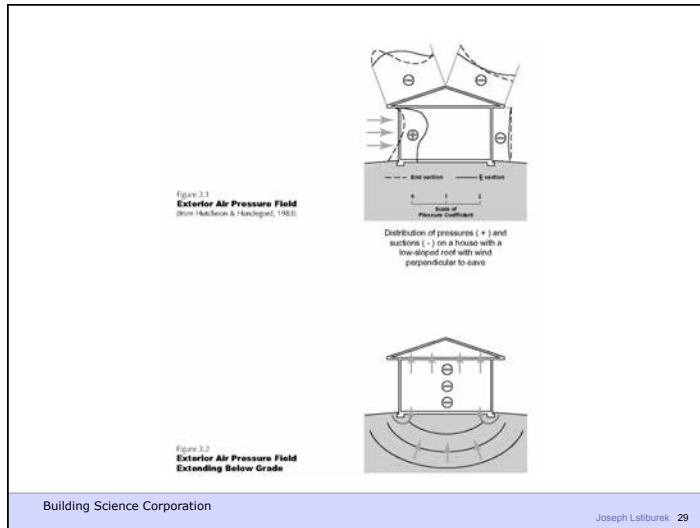



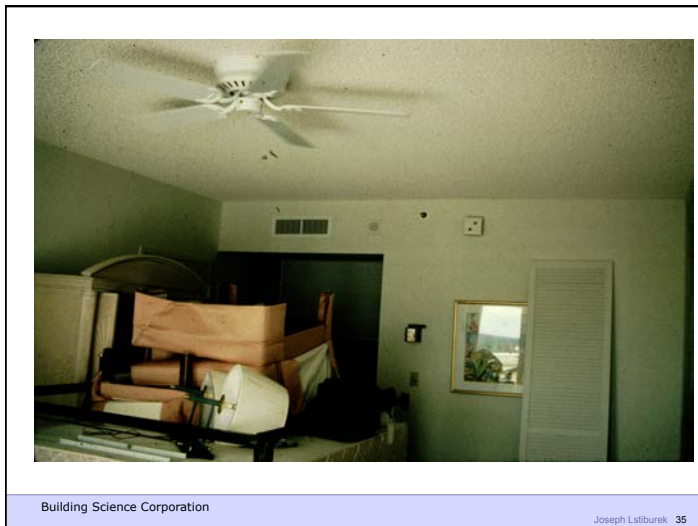
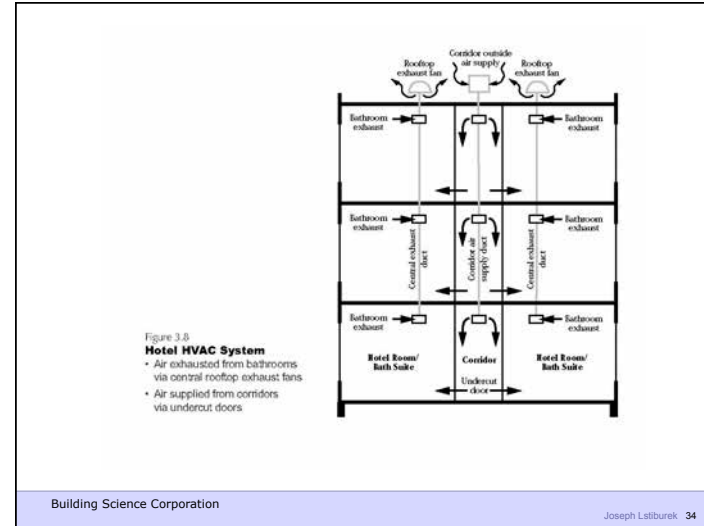

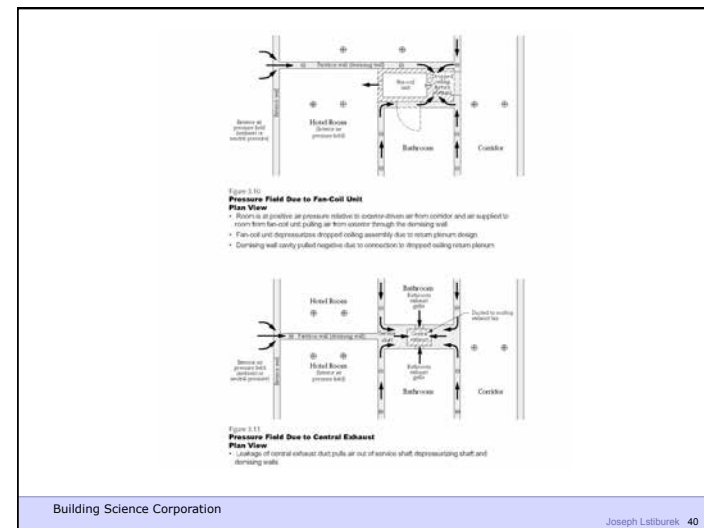
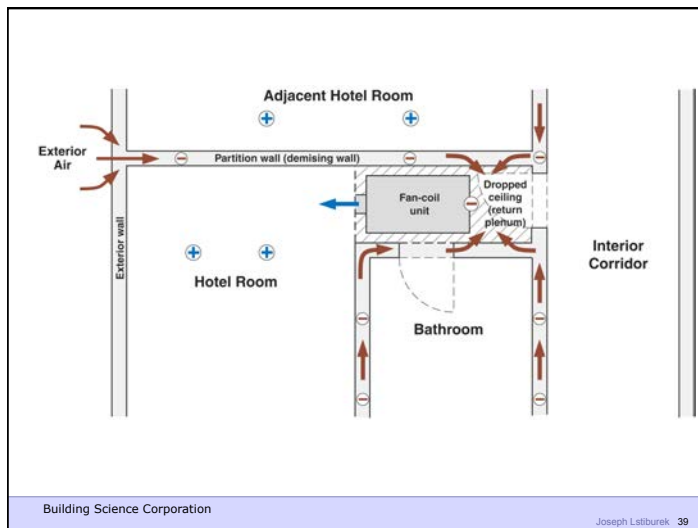
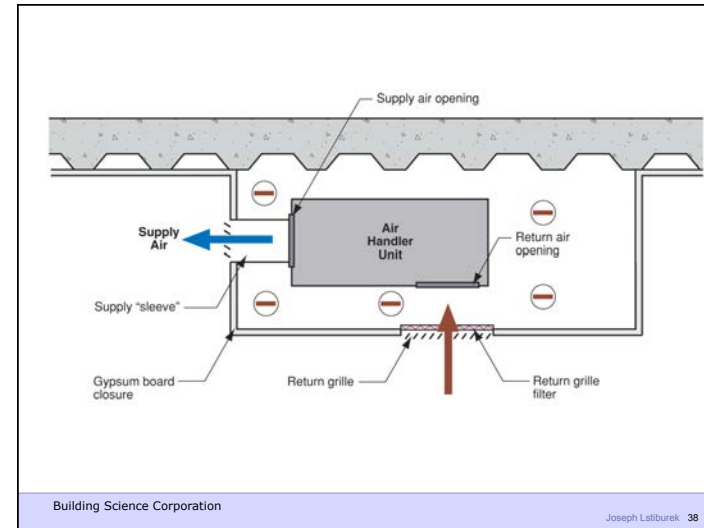
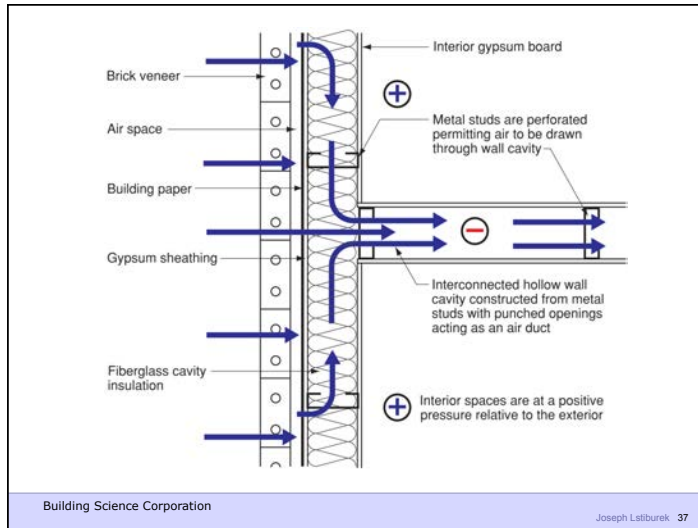

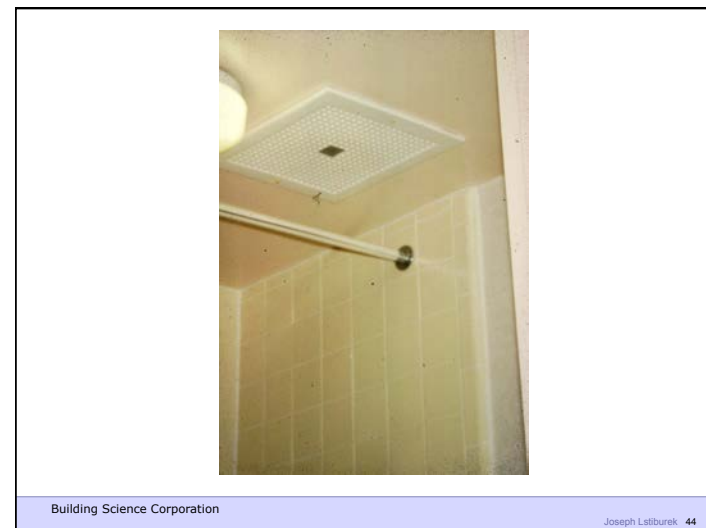

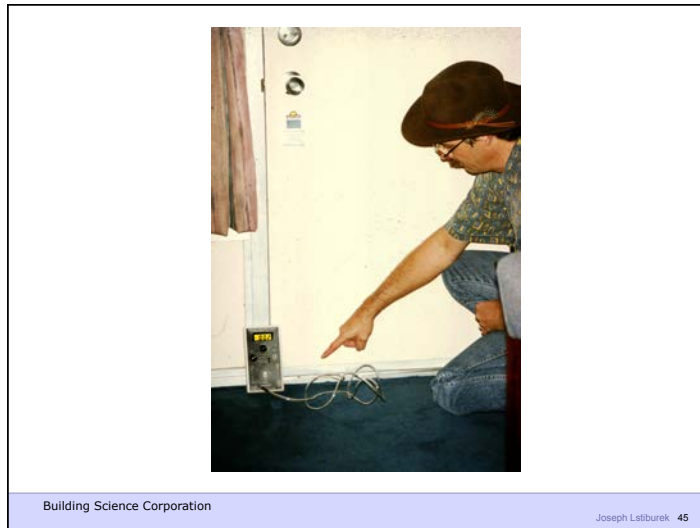

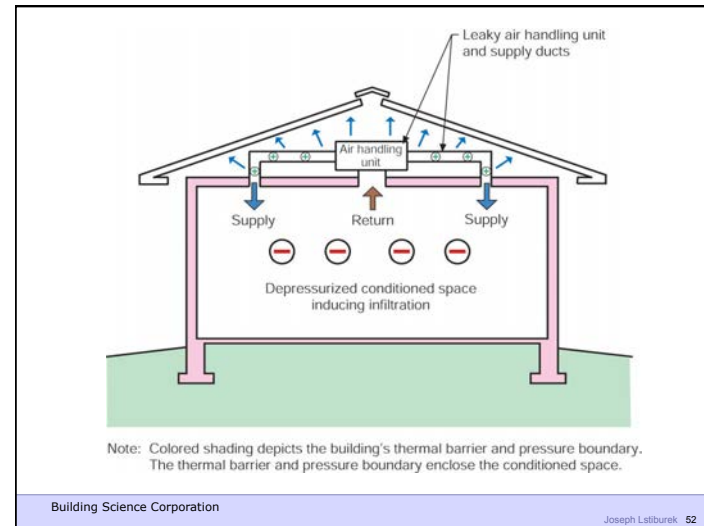
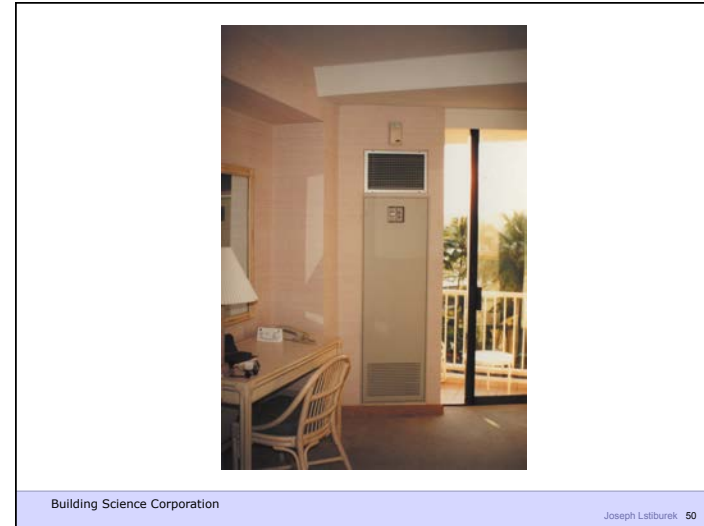

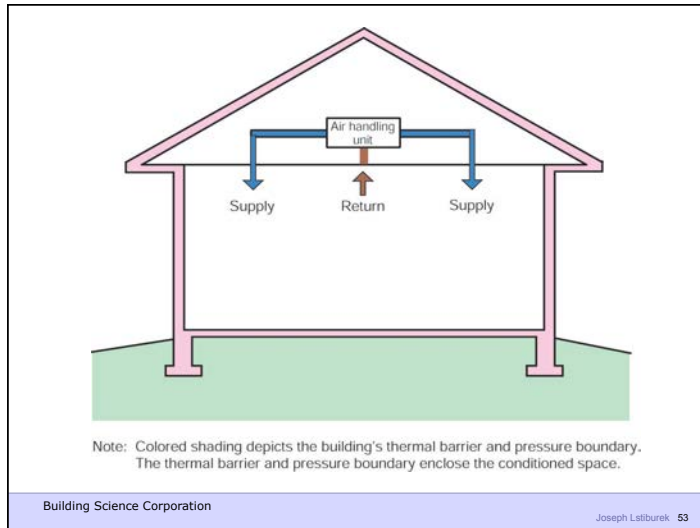

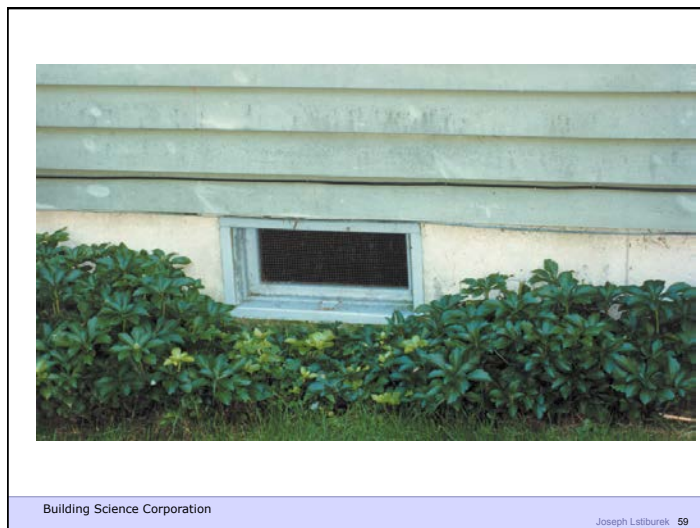
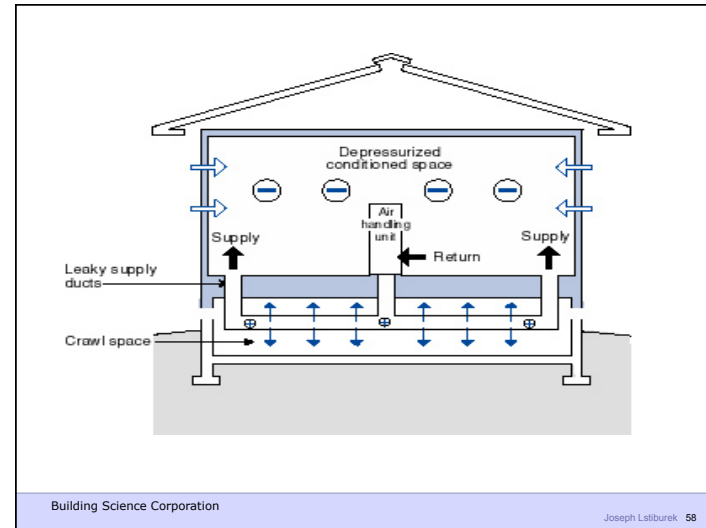
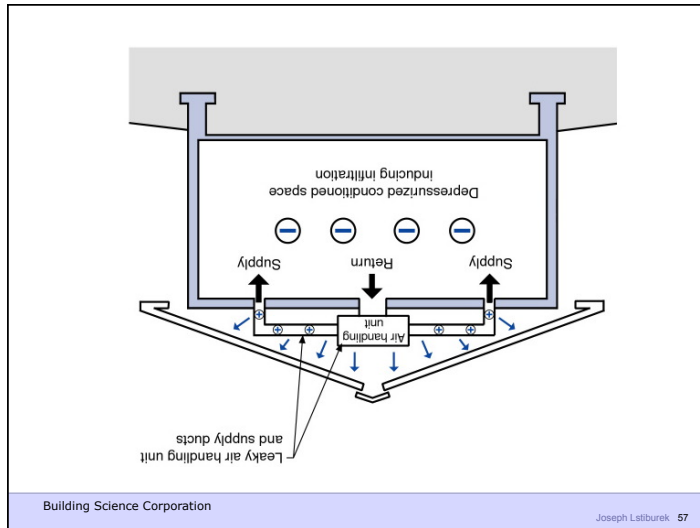

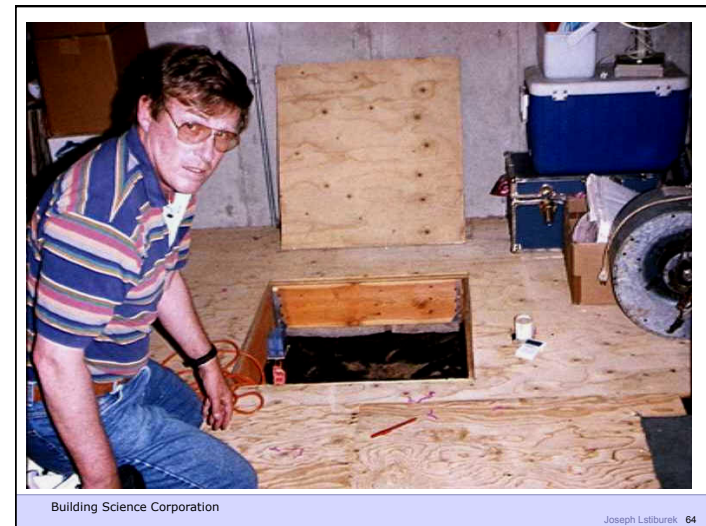
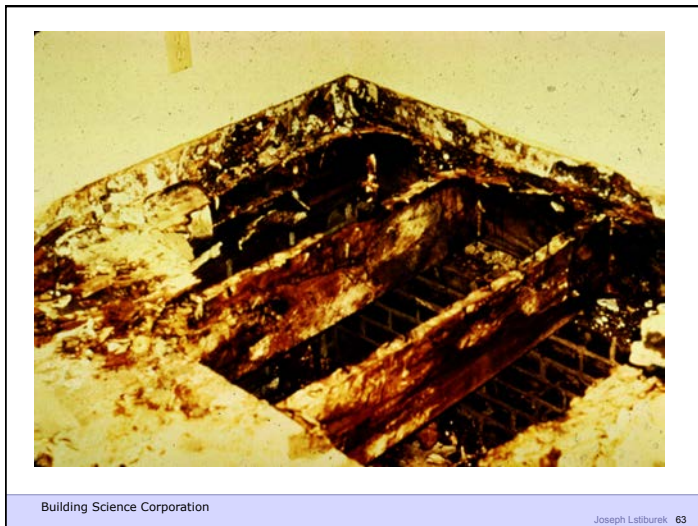
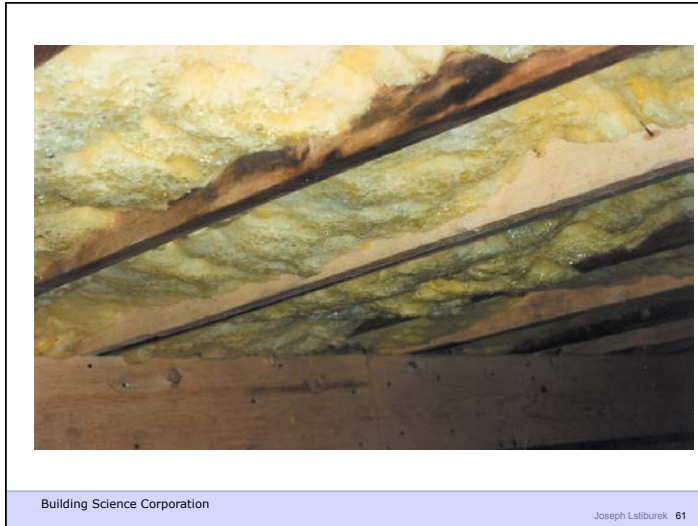



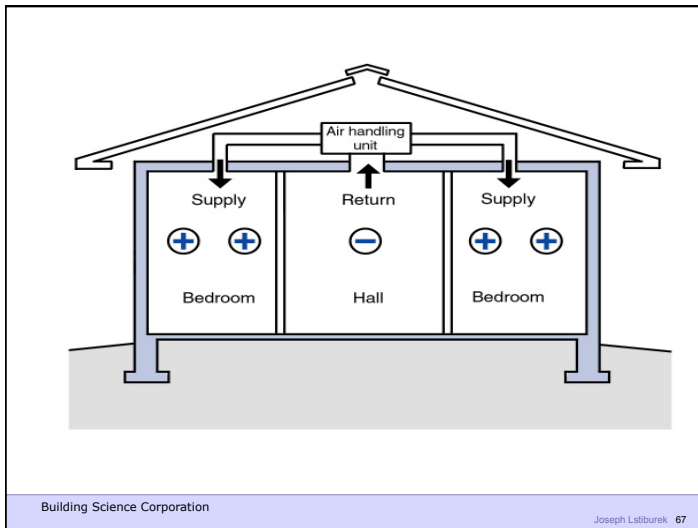

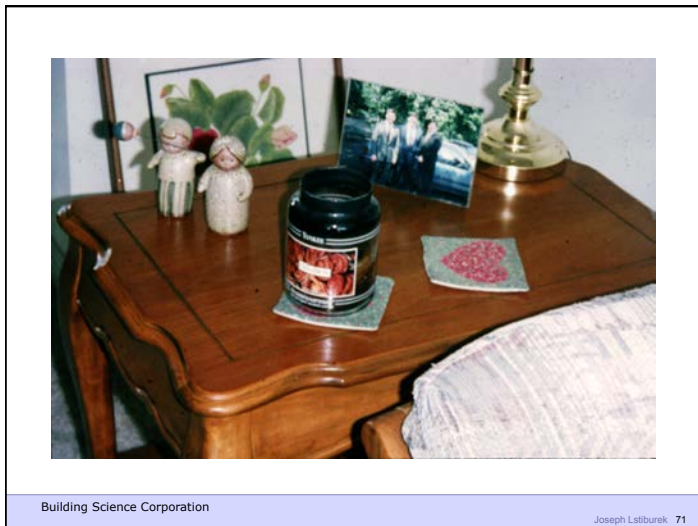
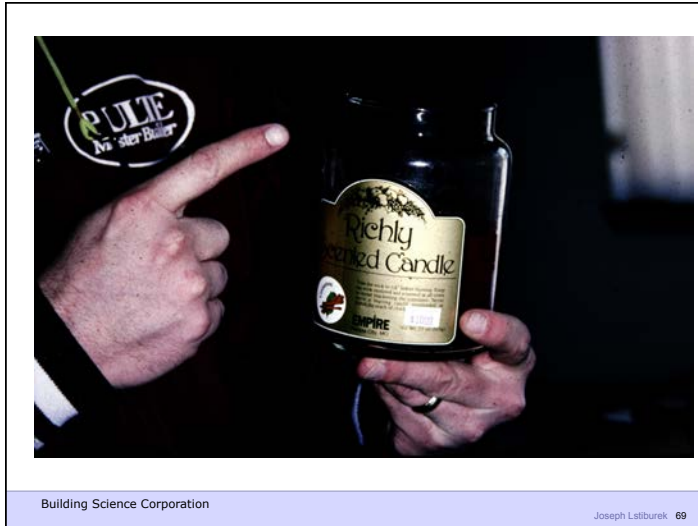

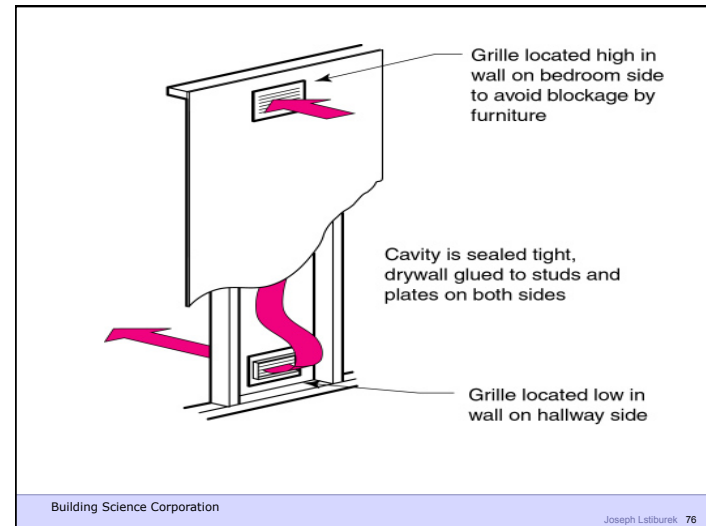



Building Science Corporation

Joseph Lstiburek 77

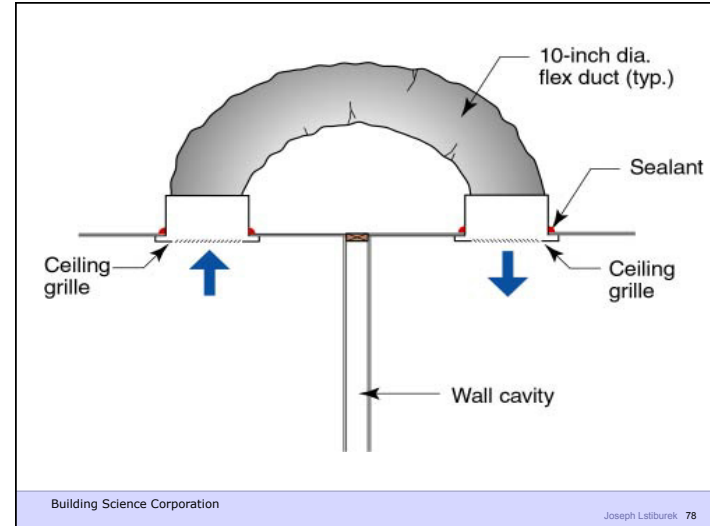

Building Science Corporation

Joseph Lstiburek 78

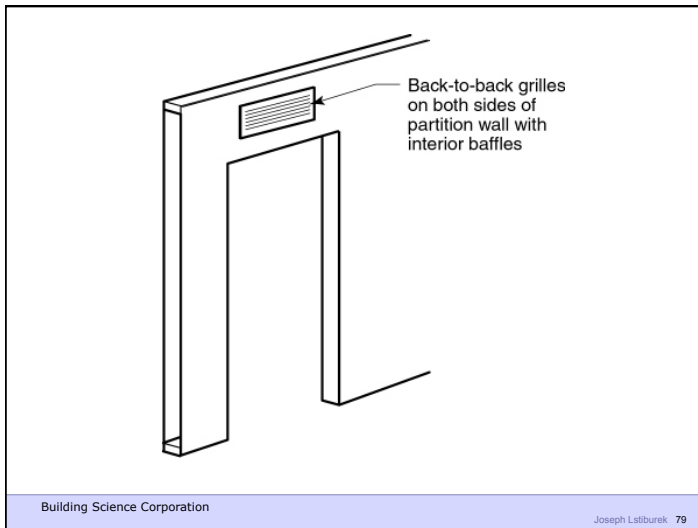

Building Science Corporation

Joseph Lstiburek 79

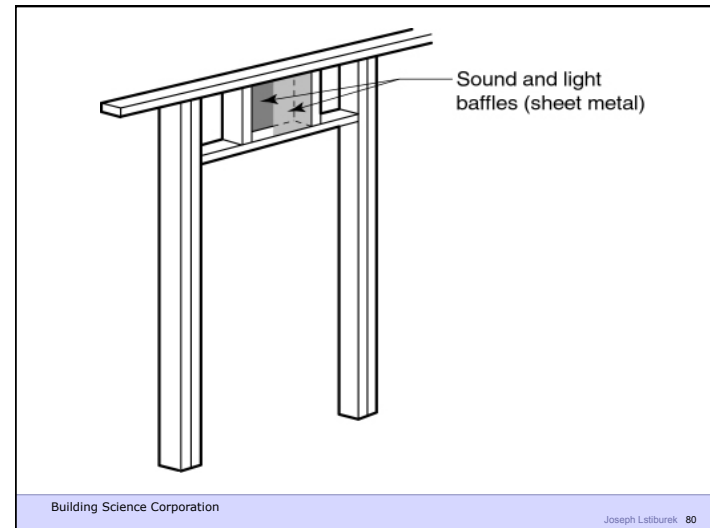

Building Science Corporation

Joseph Lstiburek 80

