

Building America Special Research Project: Space Conditioning Systems for High Performance Homes

Research Report - 1009

15 November 2010

Armin Rudd

Abstract:

The main focus for this research project is the integration of a combination space and domestic hot water heating system ("combi system") with a high-efficiency air source heat pump to optimize efficiency and comfort.

Research Project: Space Conditioning Systems for High Performance Homes

Highlights for the last quarterly report/year-end report to NETL

A.Rudd, 11/12/2010

The research plan for this project was finalized by February 2010. BSC then continued with its main focus on the integration of a combination space and domestic hot water heating system (“combi system”) with a high-efficiency air source heat pump to optimize efficiency and comfort.

An initial effort began to quantify and classify the type of challenges that face HVAC and DHW systems of low-energy homes. A review and comparison was done on the types of equipment available in North America and emerging equipment from Asia and Europe. An information sheet was prepared regarding the importance of proper refrigerant charge for cooling systems and the negative impacts of improper charge.

This project continued to evaluate combination space and domestic hot water heating system configurations and trade-offs, including application as backup for cold climate air source heat pump systems (for both new construction and existing buildings). Such an application could improve delivered comfort and extend efficient air source heat pump applicability in cold climates. A matrix of combi system applications for new and retrofit construction, with the goal of modeling some of those systems for performance and controls optimization, was developed. BSC developed a draft matrix of system configurations for TRNSYS modeling, and a preliminary TRNSYS model has been started to provide insight into optimizing the combo heating system when used as backup for an air source heat pump system. Discussions were begun with ORNL researchers, and others, to better understand the state of the art in modeling air source heat pump defrost operation. It appears that the current modeling technique applies a very basic energy use post-processing adjustment factor to approximate the energy impact of defrost operation. BSC plans to work on modeling the entire system in much more detail in TRNSYS to allow optimization strategies. This will include a short time step model that includes using actual outdoor temperature and estimates of the outdoor coil temperature, along with heat from a combi system hydronic coil to boost supply air during defrost cycles.

BSC discussed the potential to do a field evaluation of the integrated combi/air source heat pump system with some potential builder and utility partners in New England, but was not ultimately successful in initiating a project in 2010. However, a project synergy began to emerge when personnel from NYSERDA contacted BSC about pilot deep energy retrofit projects planned in Utica and Rome, NY. NYSERDA wanted to employ the combi system part of BSC’s research without the air source heat pump. BSC updated and provided system schematics to NYSERDA for consideration in their retrofit programs.

NYSERDA conducted meetings with contractors and proceeded with soliciting contractor bids for the BSC-developed system, which included a combination space and domestic hot water heating system using a tankless gas hot water heater in combination with a small storage tank. This project materialized into a research collaboration effort with NYSERDA for their deep energy retrofit program in upstate New York. BSC specifications were used in the bid package, and BSC participated in post-award meetings with the builder, mechanical contractor, and hot water heater manufacturer Rinnai. As a result of BSC’s contribution in those meetings, Rinnai now officially offers its standard 12 year warranty on its tankless condensing hot water heating equipment for space heating installations, as opposed to the previous warranty reduction to 3 years.

In July-August, three of the combi systems following the BSC design were installed in Utica and Rome, NY by NYSERDA contractors. Figure 1 shows a schematic of the system; Appendix A includes a more detailed specifications. The systems (without central cooling) were very economical, at roughly \$3,500 each installed cost. BSC provided advice during the process as necessary, and as requested by NYSERDA and the installing mechanical contractor. The Utica installation was first, which comprised two systems in a two-family (duplex) home. The systems operated

without problems for about the first month; however, water quality issues due to replacement and back-flushing of utility main water lines occurred and had to be addressed. While debris from back-flushing the main water lines did cause the water heater strainer to clog, stopping the heater from operating until the strainer was cleaned, there is still an ongoing problem with strainer clogging which BSC believes is due to the electronic water conditioner gradually clearing out old scale in the cold water feed pipes that were not replaced. In order to cure that problem, a new cold water line from the meter to the hot water heating system is being piped for each system.

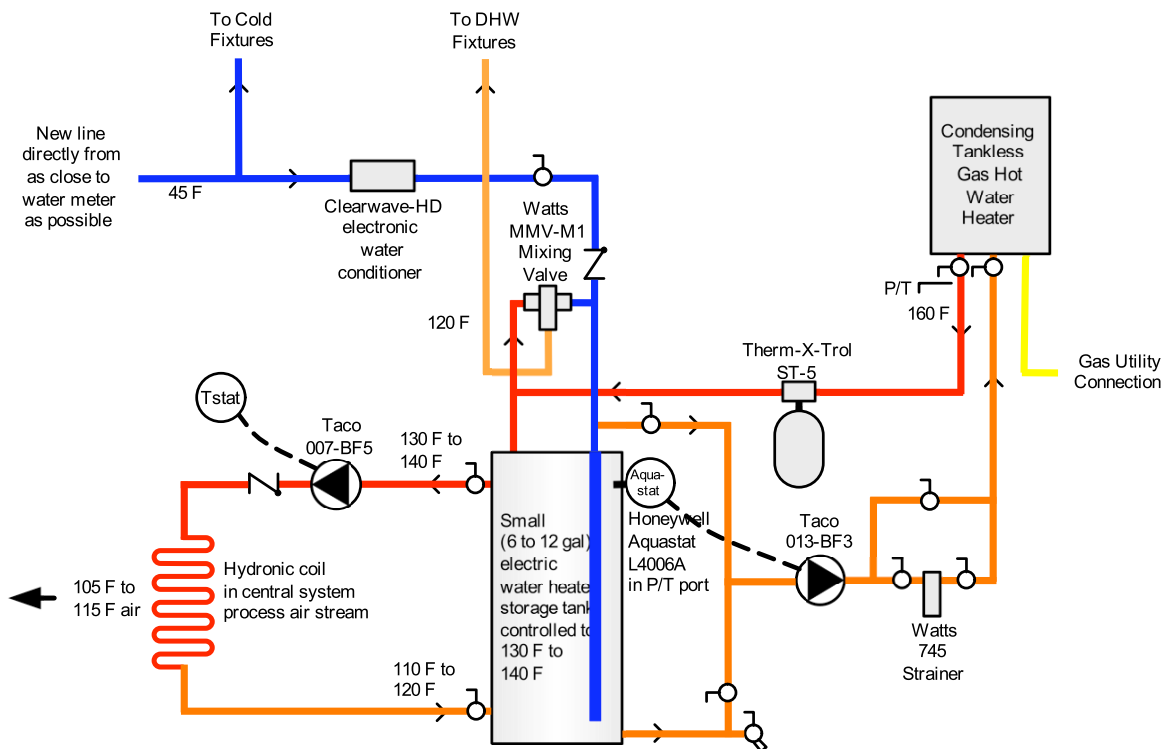

Figure 1. BSC schematic of the combination space and domestic hot water heating system installed at NYSERDA's deep energy retrofit project in Utica, NY

NYSERDA planned to track the system performance only by utility bills, so BSC initiated plans to install more detailed temperature, runtime, and energy use monitoring on these two systems to track their performance. In October, BSC developed the monitoring plan and installed the monitoring instrumentation on both of the Utica systems. Data will be collected over an internet connection. Figure 2 shows a photo of the installed combi system in Utica, NY with the attached monitoring instrumentation. The channels being monitored at 1-minute intervals for each unit are:

- Return air and supply air temperature
- Mains cold water temperature
- Mixing valve outlet temperature
- Hydronic coil inlet and outlet water temperature
- Instantaneous water heater inlet and outlet temperature
- Time stamped on/off status, duty cycle, and cycles per hour of air handler unit and instantaneous water heater
- Electrical energy consumption (W-h) of air handler unit (with integral circulator) and instantaneous water heater+circulator



Figure 2. Photos of the two installed systems in Utica, NY with monitoring instrumentation.

BSC's development of this novel combination space and domestic hot water heating system for low energy houses is gaining national attention (ACI, SMUD, etc), and particularly for retrofit projects. This space conditioning system research project is expected to continue through 2011 to track the Utica systems' performance and further inform future potential installations. Appendix B is an email exchange that describes the status of the project at the close of the NETL contract period.

Combination Space and Domestic Hot Water (DHW) Heating Mechanical System

BSC, A.Rudd, 11/12/2010

Specifications:

1. 150k to 200k Btu/h sealed combustion, condensing tankless hot water heater, side wall vent, >90% efficiency
2. Hydronic air handler unit with ECM blower and with automatic controls to purge water from the space heating plumbing circuit after long periods of inactivity.
3. Determine the locations and provide air sealed and weather protected penetrations for side wall venting for the sealed combustion water heater, for bathroom and kitchen exhaust, and for a 6" outside air intake for whole-house supply ventilation.
4. Seal all seams and joints in ductwork with approved duct mastic. Ducts must be sealed to leak not more than 5% of air handler flow at 25 Pascals test pressure. Minimize length and bends of all duct runs. Utilize rigid ductwork and mounting straps wherever possible.
5. Provide homeowner with annual maintenance guidelines, and local maintenance contact.

Suggested Components:

Rinnai RC98HPi (KA3237FFUD-US) tankless condensing gas water heater, order with optional commercial controller

<http://www.rinnai.us/tankless-water-heater/rc98hpi/>

Pre-fab plumbing valve/purge kit for Rinnai tankless water heater connections

Rinnai concentric through-wall venting: condensing wall termination kit

Whirlpool 12 gallon insulated hot water tank with top and side DHW ports

Therm-X-Trol ST-5 expansion tank

Watts MMV-M1 mixing valve

Watts 777s-100 Y strainer (bronze body, stainless steel 100 mesh screen)

Clearwave H.D. electronic water conditioner

Taco 013 bronze or stainless steel circulator

Rinnai 37AHB04512KA5 Hydronic Air Handler (ECM blower, 650-1200 cfm)

<http://www.rinnai.us/hydronic-air-handlers/>

Taco 007 bronze circulator (NOT needed if using the Rinnai hydronic air handler with integral circulator)

2- 3/4" flow check valves

1- 1/2" drain valve

7- 3/4" ball valves (full bore)

All copper tubing and fittings to complete installation

All gas piping and fittings to complete installation

All electrical wire and boxes, switches, breakers to complete installation

All ductwork to complete installation

Retrofit installed cost estimate is about \$3500 to \$4000 depending on installation circumstances.

Cooling can be added to this system--size the air handler airflow appropriately.

System Schematic with additional notes:

Condensing Tankless Gas Hot Water Heater Application
In Combination Space and Domestic Hot Water Heating System

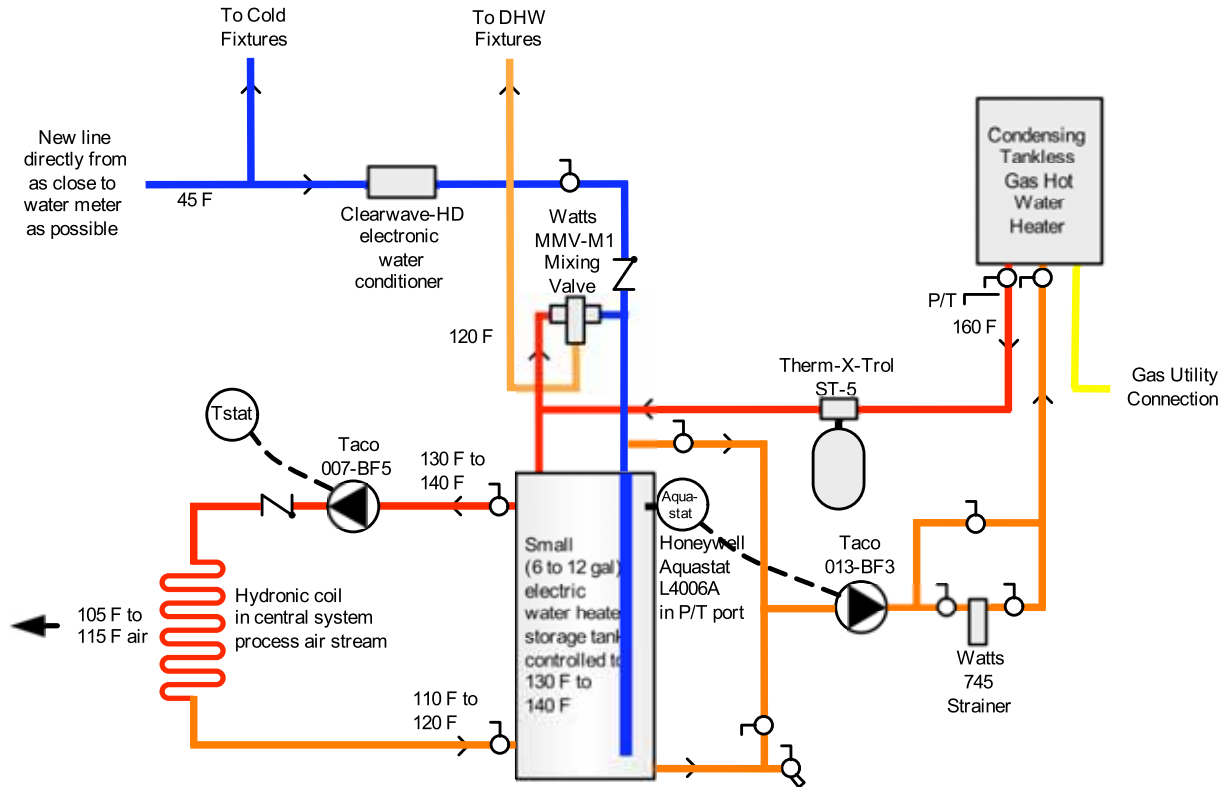

Notes:

- 1) Aquastat installed in water heater tank P/T port is wired to energize the Taco 013 circulator. Water heater tank resistance elements are NOT used. Taco 013 circulator is 1/8 HP and is capable of 5 gpm at 30' head, which is the design pressure loss recommended by Rinnai when pumping through their tankless water heater. The Rinnai warranty for this configuration remains at 12 years when using any of the condensing water heater units.
- 2) Electric water heater storage tank is available from Whirlpool with all the ports necessary. The tankless water heater loop uses tank ports common with the domestic water supply inlet and outlet. The space heating coil loop uses the available side ports. Space the tank off of floor with 2" rigid extruded polystyrene insulation.
- 3) Watts-Mueller 745 brass body strainer with 80 mesh stainless steel screen to pre-filter and extend maintenance interval of tankless water heater inlet filter.
- 4) Field Controls, Clearwave HD electronic water conditioner protects against potential scaling.
- 5) This configuration provides hot water for space heating with domestic hot water priority. This system will eliminate the low-flow and on/off flow hot water supply issues with tankless water heater usage. This system will eliminate tankless water heater short-cycling. When there is a domestic hot water draw, the coldest water will go to the tankless water heater first, thereby increasing the time of condensing operation and reducing cold water mixing in the tank.
- 6) Product brands listed are to illustrate constructability, equivalents are acceptable.

Armin Rudd, Building Science Corp., www.buildingscience.com
rev. 11/01/2010

Email exchange describing project status at close of the NETL contract period

From: arudd@buildingscience.com [mailto:arudd@buildingscience.com]
Sent: Monday, November 01, 2010 2:51 PM
To: 'Gregory A. Pedrick'
Cc: Kohta Ueno (Ueno, Kohta); Betsy Pettit (betsy@buildingscience.com); Joseph Lstiburek (joe@buildingscience.com)
Subject: RE: Taylor Ave Water Flow

Greg:

Thanks for the summary Greg, here is my follow up on that. I'll leave it to you to copy Kalex after you have reviewed this, but please copy me on what you send them so that I know what they are working from.

We are now collecting data at a 1 minute interval on both of the combi hot water systems at the 1632 Taylor, Utica site. We are measuring:
Return air and supply air temperature
Mains cold water temperature
Mixing valve outlet temperature
Hydronic coil inlet and outlet water temperature
Rinnai water heater inlet and outlet temperature
Time stamped on/off status, duty cycle, and cycles per hour of air handler unit and Rinnai water heater
Electrical energy consumption (W-h) of air handler unit (with integral circulator) and Rinnai water heater+circulator

I talked with Sean, Jim, and Gary about the short-circuiting of the HRV air (through the air handler from supply trunk to return trunk connections). I understood that Sean will be interlocking the HRV fan operation with AHU ECM fan operation via the interlock terminals provided on the Fantech HRV. I also discussed how that would not work if cooling was added to the system (because of feedback from G to Y turning the compressor on), as Winston had mentioned to us that they are already thinking about doing. In that case, it would be better to disconnect the HRV fresh air supply outlet from the central supply trunk and put the fresh air directly into the main living space via a new floor supply grille (not close to a return grille) and add an AirCycler FR-V timer (www.aircycler.com) to assure periodic fresh air distribution throughout the house.

Note that there is a problem with the green and blue thermostat wires going to the second floor. Constant fan (Fan ON) does not work on that system using either the green or blue wires, and there is no continuity through the green and blue wires. That will need to be fixed anyway, but certainly before the HRV interlocking or AirCycler FR-V timer can be applied.

Kohta and I cleaned the Rinnai inlet filters several times while we were there, and we did various things to investigate the problem with debris plugging the systems. I have concluded that a home-run line should be installed from the outlet of the water meters to the mains cold water inlet of each combi system. This will bypass all of the existing water supply lines that are feeding the combi systems which are likely being gradually cleaned out by the Clearwave water conditioning unit.

Sean, Jim, Gary and I went over the moving of the check valve in both cold water lines to just before the mixing valve. We also went over adding a bypass leg for sending water to the Rinnai water heater from a choice of two locations according to the attached updated schematic. This will allow us to both further isolate the source of debris and to test the possibility of achieving a higher percentage of time for condensing operation.

We have received permission from the homeowners to work directly with them within the next month or so to install an internet connection to the dataloggers for retrieving the datalogger data.

Thanks for all of your great work and cooperation throughout this project. We look forward to more, and your comments and feedback are always welcomed.

Respectfully,

Armin Rudd
717.867.0123 direct, 717.304.3814 cell
arudd@buildingscience.com

Building Science Corp
30 Forest Street, Somerville, MA 02143
978.589.5100, 978.589.5103 fax
www.buildingscience.com

From: Gregory A. Pedrick [mailto:gap@nyserda.org]
Sent: Wednesday, October 27, 2010 7:13 AM
To: Gary Edwards; Michael Pfluke
Cc: arudd@buildingscience.com
Subject: Taylor Ave Water Flow

Gary, Mike,

I hope one of you will see this the morning of 10/27, and I will call Gary this A.M.

Armin Rudd and I had a productive afternoon yesterday (10/26) making some further discoveries with “possible” causes/solutions to the repeated sedimentation deposits that are clogging the Rinnai tank less strainers. Some of the remedies can be handled by Sean if he can go to the site today (10/27) and review with Armin who will be at the Taylor Ave. site until mid-afternoon connecting data logging equipment on the air handler and tank less systems.

1. We met with Dave Jones at Mohawk Valley Water Authority after talking with Winston (homeowner’s son) and discussed the debris, frequency and remedies. Some of his remarks lead us to consider some other possible causes which Armin can talk with Sean about.
2. With the location of the Clearwave water conditioner, as it relates to older existing piping and its function as a de-scaler of the pipes, operation (its intended function) may be releasing some of the older scale in the pipes and it may be getting deposited and coagulating in the bottom of the 12 gallon storage tank. One of the remedies Armin will discuss with Sean is to relocate the pipe that goes to the Taco BF3 circulator from the bottom of the tank up to the top. This is reflected in the most recent schematic that Armin shared with us a few weeks back.
3. Armin had 2 new watts strainers, similar to the ones you have ordered, and yesterday we placed the finer meshed screens (100) over the existing screens all into the existing brass fitting. This may become a solution in of itself, but we will not know I the immediate timeframe.

Other issue that Armin will discuss with Sean, is the Fantech HRV unit and its ducting. I discovered with Armin’s knowledge that the Fantech unit as it is currently installed is merely short circuiting the supply air with the return air in a loop, while the fan runs continuously. There are a couple of solutions to correct this, which Armin can explain to Sean when he is there today.

From this knowledge I gained, we may be able to use the Rinnai air handler ECM motor to circulate air at the Rome project, and avoid installing a Fantech unit altogether.

I will call Gary this A.M., but hoping you will be able to read this before (so you are not blindsided by these discoveries of yesterday) when I call.

As usual, your work looks impressive and I appreciate all the efforts Kalex is making on these projects.

Thanks.

Gregory A. Pedrick, C.E.M.
Project Manager Buildings R&D



(518) 862-1090, x3378
(518) 862-1091, fax
gap@nyserda.org

"We can't solve problems by using the same kind of thinking we used when we created them." Albert Einstein

RR-1009: Building America Special Research Report Space Conditioning Systems for High Performance Homes

About this Report

This report was prepared with the cooperation of the U.S. Department of Energy's, Building America Program.

About the Authors

Armin Rudd is a principal engineer at Building Science Corporation in Somerville, Massachusetts. More information about Armin Rudd can be found at www.arminrudd.com.

Direct all correspondence to: Building Science Corporation, 30 Forest Street, Somerville, MA 02143.

Limits of Liability and Disclaimer of Warranty:

Building Science documents are intended for professionals. The author and the publisher of this article have used their best efforts to provide accurate and authoritative information in regard to the subject matter covered. The author and publisher make no warranty of any kind, expressed or implied, with regard to the information contained in this article.

The information presented in this article must be used with care by professionals who understand the implications of what they are doing. If professional advice or other expert assistance is required, the services of a competent professional shall be sought. The author and publisher shall not be liable in the event of incidental or consequential damages in connection with, or arising from, the use of the information contained within this Building Science document.