

Combo Space/Water Heating Systems—“Duo Diligence”

Research Report - 0213

September-2002

Building Science Corporation

Abstract:

Combo systems use a gas water heater to provide domestic water and space heating. Find out when its appropriate to use such a system and guidelines for doing it right.

COMBO SPACE/WATER HEATING SYSTEMS – “DUO DILIGENCE”

Combo systems use a gas water heater to provide domestic water and space heating (see diagrams at top right).¹ It's pretty slick having one equipment set-up handle these two. You can save on floor space and equipment/ducting costs; and adding space heating demands to a properly sized tank water heater more fully employs its capacity, increasing its efficiency during the heating season. These systems can be first-cost effective when the upsized water heater plus the air handler coil (and any reduction of gas supply lines and venting that can be credited to the combo system) cost less than a furnace and water heater.

This type of combo system is best suited for relatively modest and/or energy-efficient single-family detached and multi-family dwellings with heating loads of 25 kBtu/hr or less at design temperatures. How much you will need to upsize your gas water heater for a combo system is a function of domestic hot water

needs (usually correlated to square footage/number of bedrooms), the thermal performance of your building envelope, and your climate. (See chart on sizing on next page.)

This all sounds really elegant and straightforward, but sad to say it is not. BSC has found combo systems difficult to configure with existing commercially available equipment and tricky to install. Here are the (sometimes bloody) details:

a. Trades coordination If you are lucky, you have one trade contractor that handles plumbing and HVAC installations. If you are really lucky, that one contractor will be the type to persevere with the integrated plumbing and HVAC installation that combo systems require. Chances are, though, that you will need to have two really savvy trade contractors (plumbing and HVAC), two that are willing and able to work together on

¹ Although there are a lot of different types of combo systems, in our Building America production homes combo systems have meant the types of systems shown in the diagrams. Not covered in this discussion are systems such as the Lennox CompleteHeat™ or American Water Heater Polaris Comfort™ systems or boiler-based combo systems using equipment such as the Heat Transfer Products Munchkin™. These are high-efficiency (90+%), high capacity (100 Btu), premium systems designed primarily for larger and/or custom homes, not usually considered for production homes.

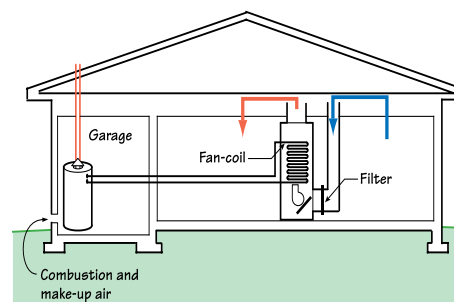

Standard/traditional gas water heater in a garage supplied with combustion and make-up air.

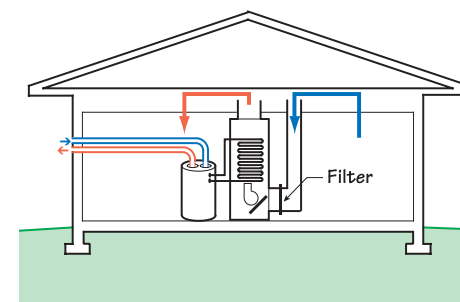

Sealed combustion power vented water heater located in the conditioned space (in utility room with air handler); water heater flue gases exhausted to exterior using fan; combustion air supplied directly to water heater from exterior via duct.

U.S. Department of Energy Building America production builder, Artistic Homes of Albuquerque, New Mexico, uses the combo system with standard gas water heater installed in the garage for all of their homes. They use[†]:

- a 50-gallon/40 kBtu/hr unit for their smaller production homes (1,000 - 1,700 ft²);
- a 50-gallon/50 kBtu/hr unit for their larger production homes (1,500 - 2,000 ft²) and;
- a 75-gallon/75 kBtu/hr unit for their custom homes (2,200 - 3,000 ft²)



Air handler closet located in hallway



“Guts” of the air handler with heat exchanger



Garage installation of water heater

[†] Your equipment size may vary depending on your climate and type of construction.

Combo-System Water Heater Sizing

Calculated for:
140°F tank setpoint, 76% recovery efficiency, 55°F entering water,
1.5 gpm domestic draw for 15 min, 112°F minimum tank temp

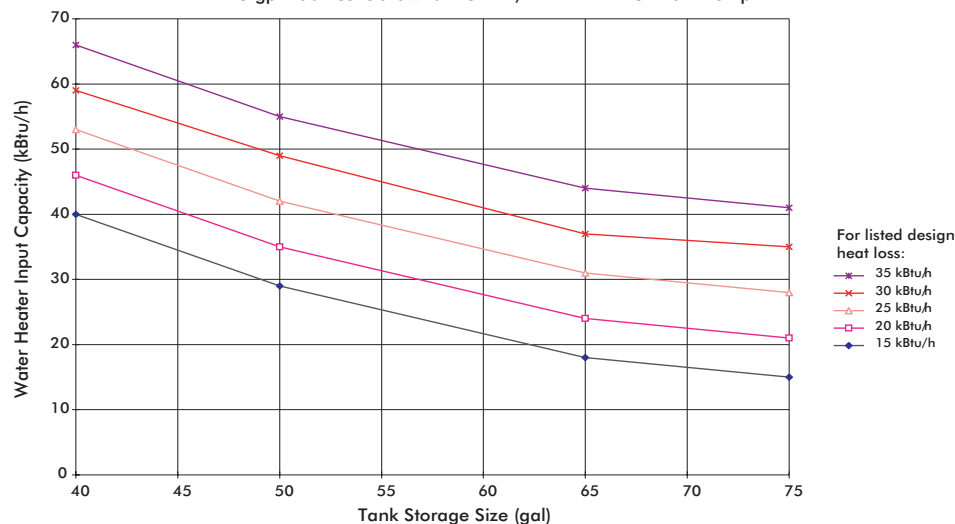

Proper water heater sizing should take into account the tank capacity, the Btu input of the water heater, and the space heating load at design conditions. These sizing recommendations are based on Building Science Corporation analysis and field experience for the specific yet realistic conditions cited.

this system. A tall order, to say the least.

b. Installation Given that combo systems involve (1) a coil carrying hot water through an air handler that also supplies cooling, and (2) a single source of heat supplying two very different demands, there a number of installation items that have just got to be right (see installation diagram at right)

- **Configuration** Proper performance of the tank water heater for both space and domestic water heating

requires specific configuration with respect to the piping entry and exit for the space heating loop. Note that while positioning the air handler above the water heater can reduce the potential for thermo-siphoning, space limitations often preclude this arrangement.

- **Mixing valve** To achieve a comfortable delivered air temperature ($\approx 120^\circ\text{F}$), the tank water heater must be set at an elevated temperature ($\approx 140^\circ\text{F}$). *A mixing valve is required to temper the domestic water*

Plumbing Schematic for Recommended Installation

not to scale

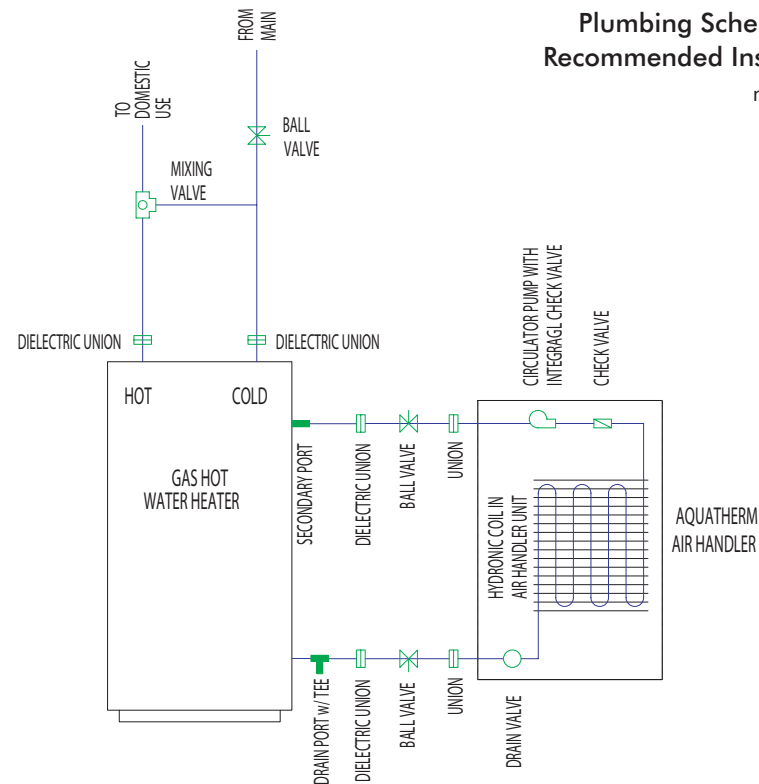

- This schematic describes what BSC feels is the most effective way of integrating the space heating exchange loop with the tank water heater: the hot water supply to the hydronic coil exits the tank at the secondary pressure & temperature relief valve port off the side of the tank and returns to the tank by way of a tee in the drain port. The other typical set up—both lines of the space heating exchange loop tapping into plumbing lines at the top of the tank—can introduce mixing valve performance problems created by pressure differences.

NOTE: Be sure that your tanks come with the T&P valve installed at the top of the tank, with the unused secondary T&P port at the upper side of the tank. If a tank comes with the T&P valve already installed in the upper-side port, then the T&P valve must be moved to the port at the top of the tank according to manufacturer's instructions.

- A recommended mixing valve is Watts model 1170-US (Note: Be sure to follow the manufacturer's instructions for removing the thermostatic core before sweating).
- Note the isolation valves in the space heating exchange loop — they really make any system servicing easy compared to a real pain in their absence.
- The following companies make compact air handlers with integrated hot water coils (listed alphabetically): AllStyle (Houston, TX), ApolloHydroHeat (Ashland City, TN), First Company - AquaTherm (Dallas, TX), Goodman Manufacturing (Houston, TX), MagicAire (Wichita Falls, TX). The other option is to use a standard air handler unit and add a cased hot water coil from the same or another manufacturer. Be sure to account for the additional static drop through this add-on hot water coil when designing the HVAC system.
- The only control that we have found for priority temperature control of a combo system is the Lipidex combo STAT.

temperature delivery to eliminate the risk of scalding water and injury.

During installation, these valves must be protected from the damage that can result from overheating.

- **Check valve** Combo systems must have a check valve that prevents thermo-siphoning of tank water when the space conditioning system is in the cooling mode. This thermo-siphoning can occur when water in the heat exchanger loop is cooled during air conditioning, the cooled water falls to the tank and is replaced by rising heated water, that cools, etc. (Both water heating and air conditioning costs go up when this happens). Trouble is, this valve is really prone to jamming from contaminants—flux, soldering debris, pipe tailings, etc.—during installation. *The entire system must be completely and thoroughly flushed as part of the installation, a surprisingly difficult detail to impress upon many technicians.*
- **Controls** Combo systems require two special control features:
 1. priority control that regulates flow when there is simultaneous space heating and domestic hot water demand, and;

2. cycling control that kicks on the heat exchanger line pump for one minute if the pump has not been on for 24 hours (this keeps water from standing for extended periods of time in this loop during the non-heating season)

While we certainly have the technology for this type of electronic logic, there are not many reliable controls available that accomplish this for combo systems.

- c. **Service life and maintenance** If the water heater in a combo system goes out during the heating season, you lose both hot water and home heating. *Maintenance and service checks are therefore doubly important for combo systems.* While it's reasonable that the much higher circulation rate and frequency of tank water heaters in combo systems should reduce tank degradation from two common foes, tank sediment and corrosion, scheduled maintenance is still critical for combo systems. Flushing your tank water heater and regularly replacing the anode go a long way. A great resource is: <http://www.waterheaterrescue.com>.

- d. **Operation** The most efficient year-round operation of the combo system depends on the *homeowner being willing and able to change the tank water heater temperature setting from 140°F (during the heating season) to 120°F (during the non-heating season) and back again.* Otherwise, unnecessary heat loss occurs during the non-heating season or insufficient comfort is experienced during the heating season.

The Bottom Line: BSC has Building America production builders with the right combination of trade coordination, experienced field technicians, attention to detail, and sensitivity to the issues above for whom the benefits of combo systems—to their operations and to their customer utility bills—make it the right system. But until the manufacturers of water heaters, air handlers, and controls for combo systems demonstrate more coordination, technical and field support, and develop a greater sense of responsibility for combo system

performance, *BSC does not recommend combo systems for production homes.*

Stout of heart, stay the course; all others, take note.

For custom homes, we still can recommend combo systems, IF the following conditions are met:

- Guaranteed proper flushing of the plumbing system before startup to ensure properly functioning check valve;
- installation per diagram in sidebar above;
- air handler not located above the water heater to reduce the thermo-siphon potential;
- tank water heater with large enough sizing/capacity to eliminate the need for priority control;
- high-quality air handler/fan coil, such as the Carrier with ECM.

About this Report

This report was prepared for the US Department of Energy’s Building America Program.

Direct all correspondence to: Building Science Corporation, 30 Forest Street, Somerville, MA 02143.

Limits of Liability and Disclaimer of Warranty:

Building Science documents are intended for professionals. The author and the publisher of this article have used their best efforts to provide accurate and authoritative information in regard to the subject matter covered. The author and publisher make no warranty of any kind, expressed or implied, with regard to the information contained in this article.

The information presented in this article must be used with care by professionals who understand the implications of what they are doing. If professional advice or other expert assistance is required, the services of a competent professional shall be sought. The author and publisher shall not be liable in the event of incidental or consequential damages in connection with, or arising from, the use of the information contained within this Building Science document.