

Joseph Lstiburek, Ph.D., P.Eng, ASHRAE Fellow

# Building Science

---

Adventures In Building Science

[www.buildingscience.com](http://www.buildingscience.com)

# What is a Building?

# A Building is an Environmental Separator

- Control heat flow
- Control airflow
- Control water vapor flow
- Control rain
- Control ground water
- Control light and solar radiation
- Control noise and vibrations
- Control contaminants, environmental hazards and odors
- Control insects, rodents and vermin
- Control fire
- Provide strength and rigidity
- Be durable
- Be aesthetically pleasing
- Be economical

# Order of Magnitude

# Order of Magnitude

1 to 10

10 to 100

100 to 1000

1000 to 10000

First Order Effects, Second Order Effects.....

# Arrhenius Equation

For Every 10 Degree K Rise  
Reaction Rate Doubles

$$k = Ae^{-E_a/(RT)}$$



# Damage Functions

Water

Heat

Ultra-violet Radiation

# The Three Biggest Problems In Buildings Are Water, Water and Water...

# 80 Percent of all Construction Problems are Related to Water

# Thermodynamics

Zeroth Law – Equal Systems

First Law - Conservation of Energy

Second Law - Entropy

Third Law – Absolute Zero

# 2<sup>nd</sup> Law of Thermodynamics

In an isolated system, a process can occur only if it increases the total entropy of the system

Rudolf Clausius

Heat Flow Is From Warm To Cold

Moisture Flow Is From Warm To Cold

Moisture Flow Is From More To Less

Air Flow Is From A Higher Pressure to a  
Lower Pressure

Gravity Acts Down



Moisture Flow Is From Warm To Cold  
Moisture Flow Is From More To Less

Moisture Flow Is From Warm To Cold  
Moisture Flow Is From More To Less

Thermal Gradient – Thermal Diffusion  
Concentration Gradient – Molecular Diffusion

Moisture Flow Is From Warm To Cold  
Moisture Flow Is From More To Less

Thermal Gradient – Thermal Diffusion  
Concentration Gradient – Molecular Diffusion

Vapor Diffusion

# Thermodynamic Potential



# PSYCHROMETRIC CHART

NORMAL TEMPERATURES

SI METRIC UNITS

Barometric Pressure 101.325 kPa

SEA LEVEL

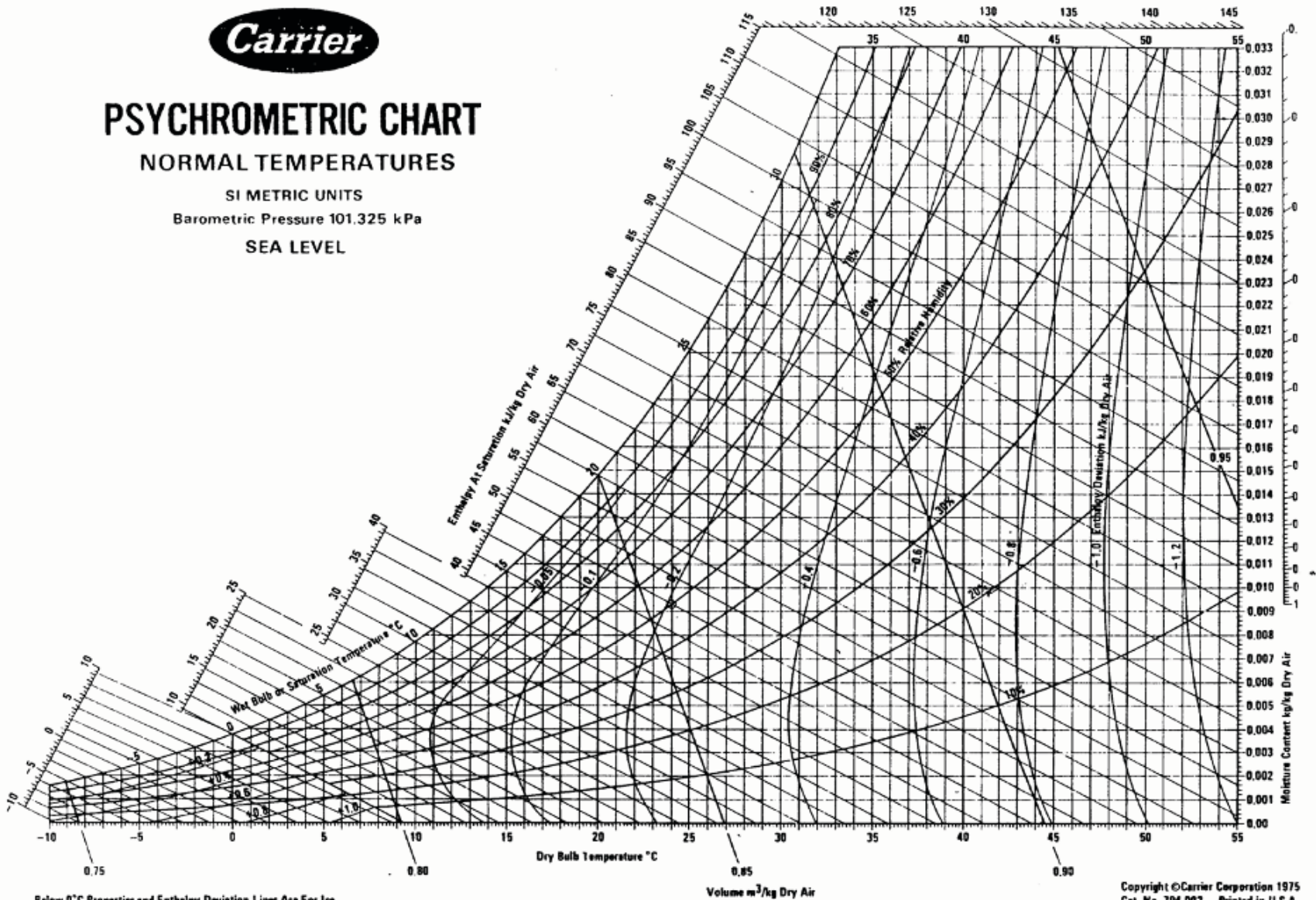

Below 0°C Properties and Enthalpy Deviation Lines Are For Ice

Copyright ©Carrier Corporation 1975  
Cat. No. 794 002 Printed in U.S.A.



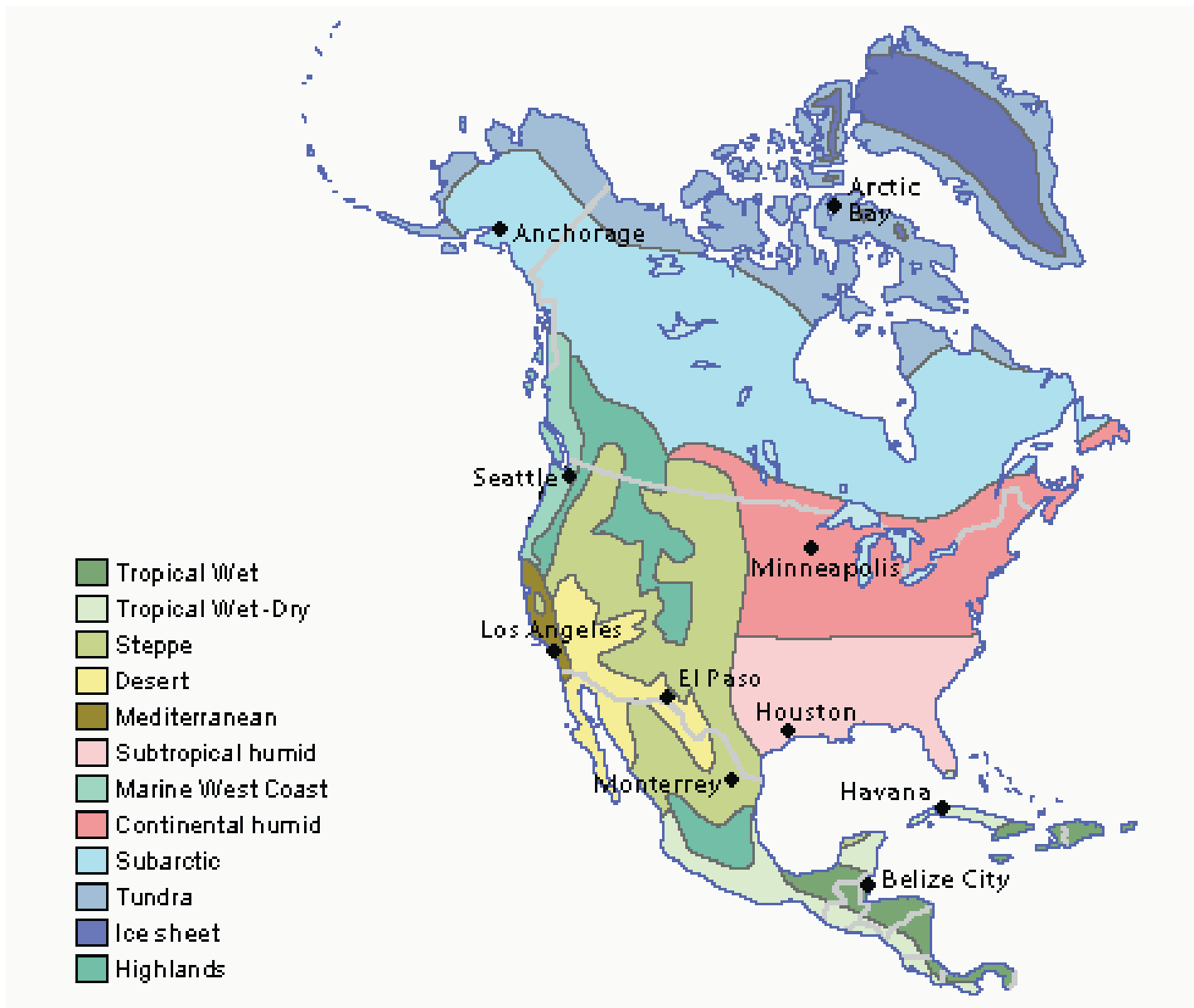

Map of DOE's Proposed Climate Zones

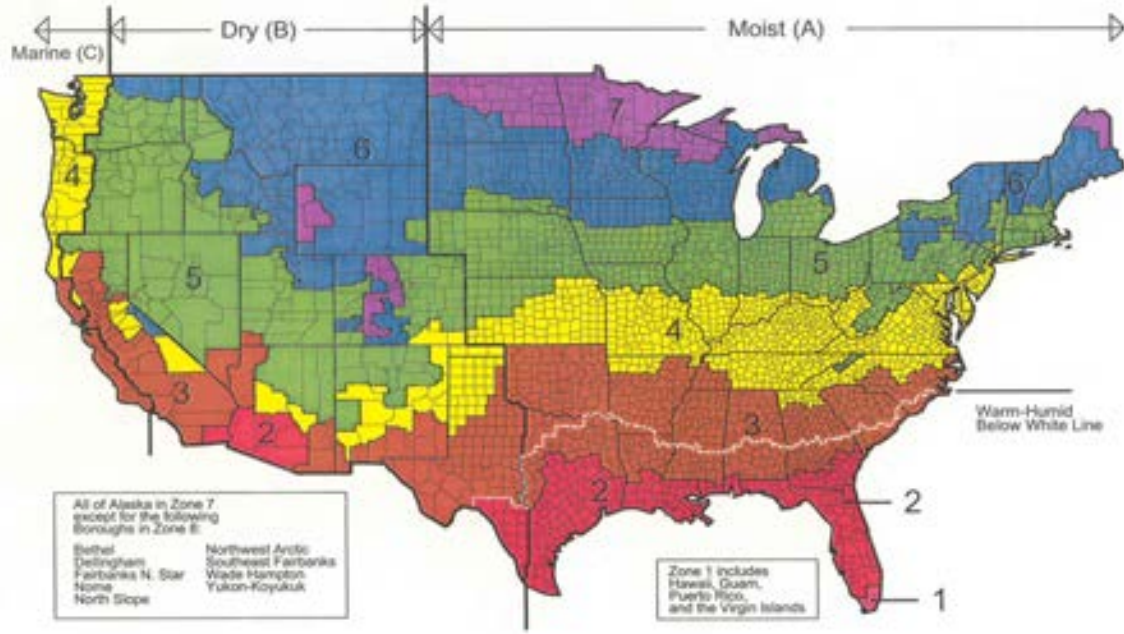

March 24, 2003





**Exposure**

Extreme	Over 60"
High	40" - 60"
Moderate	20" - 40"
Low	Under 20"



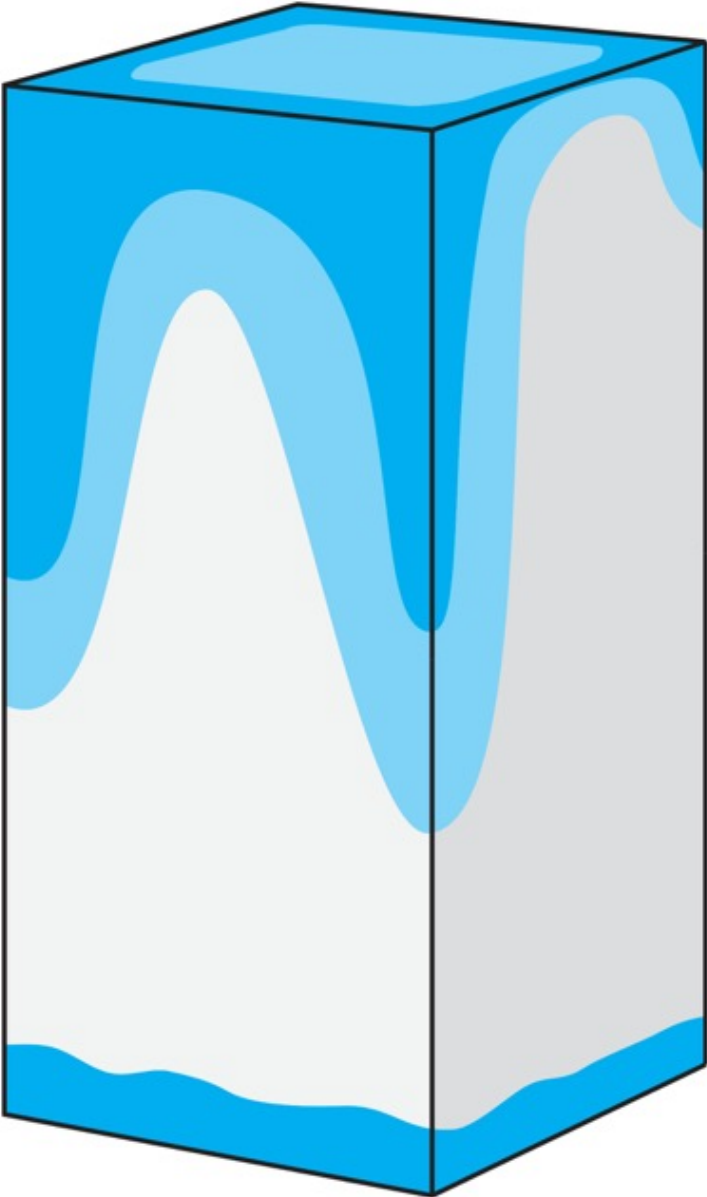

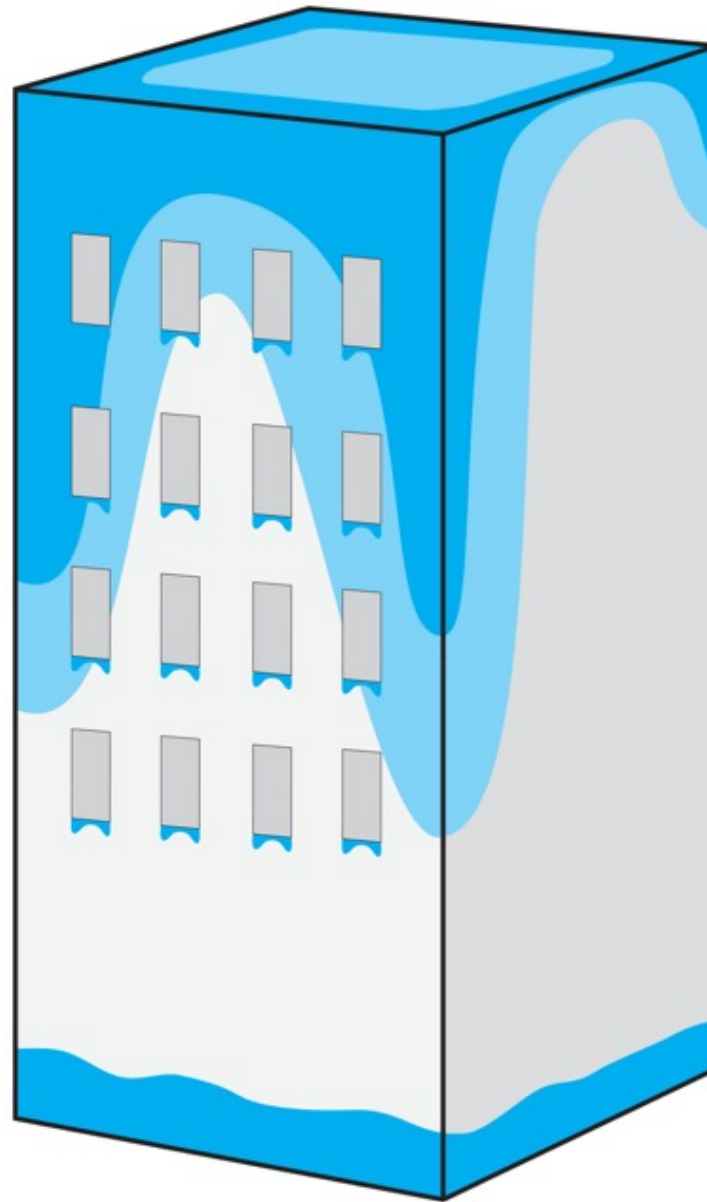

Water Control Layer

Air Control Layer

Vapor Control Layer

Thermal Control Layer

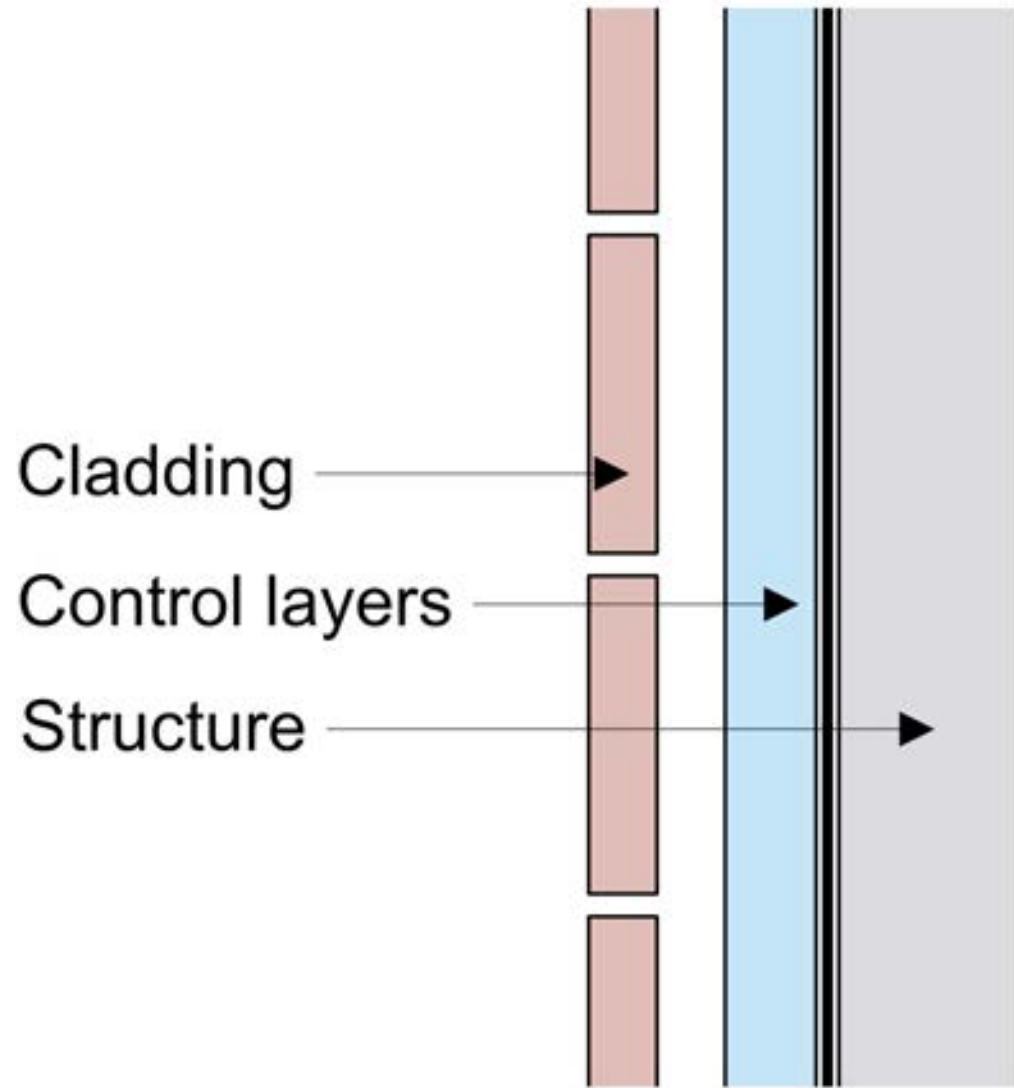

**Wall**

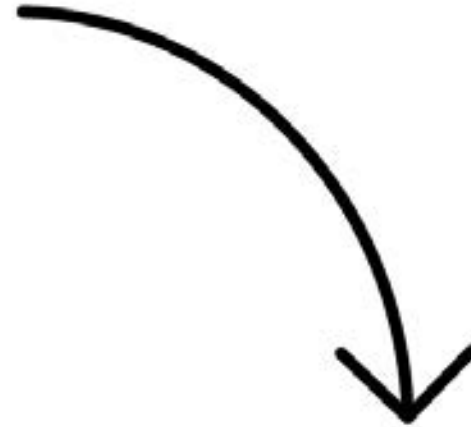
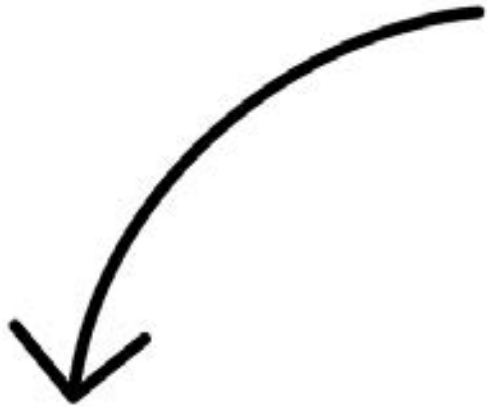

**Slab**



**Roof**

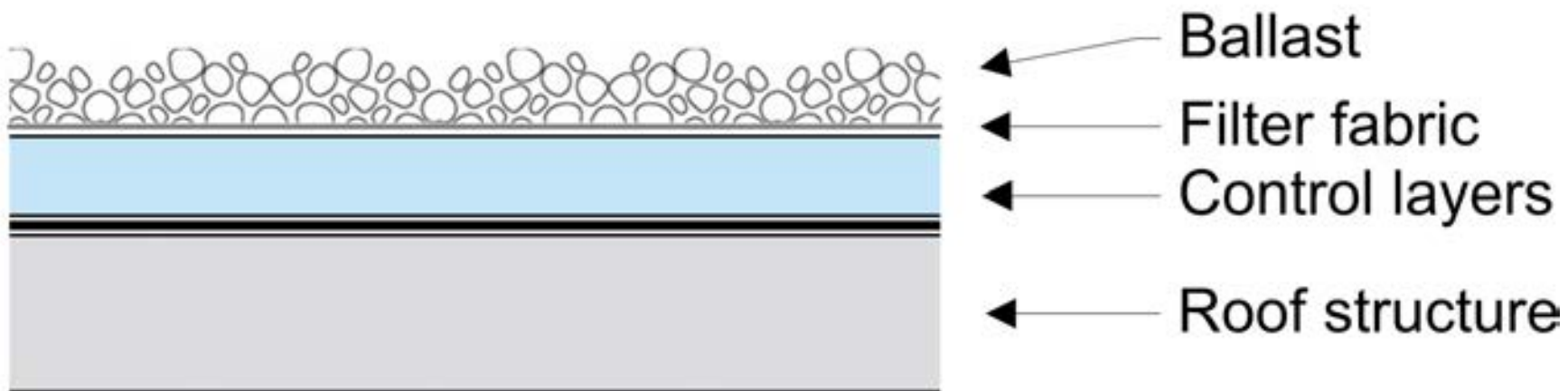



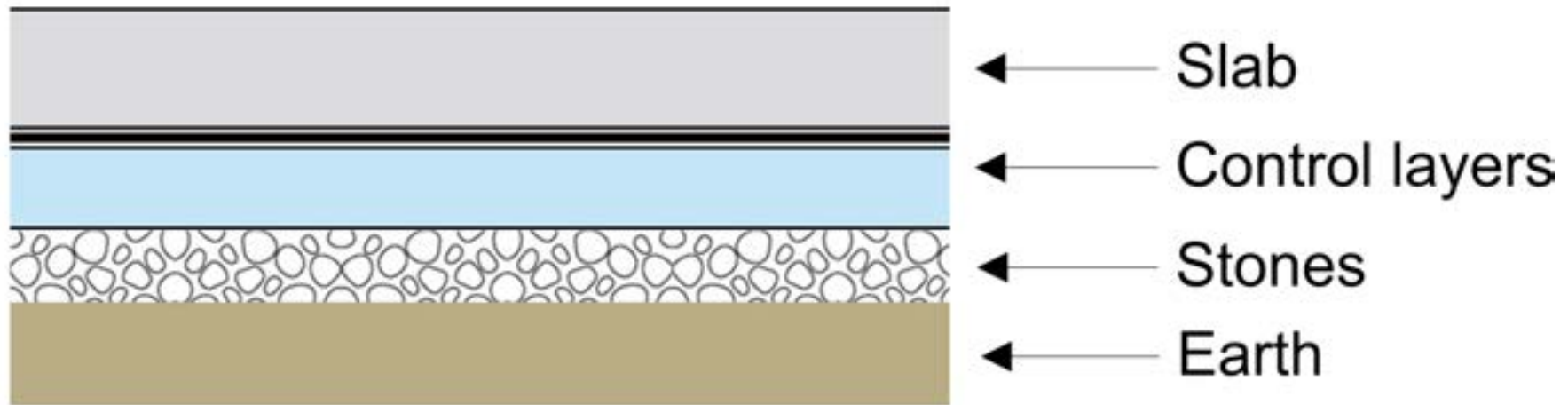

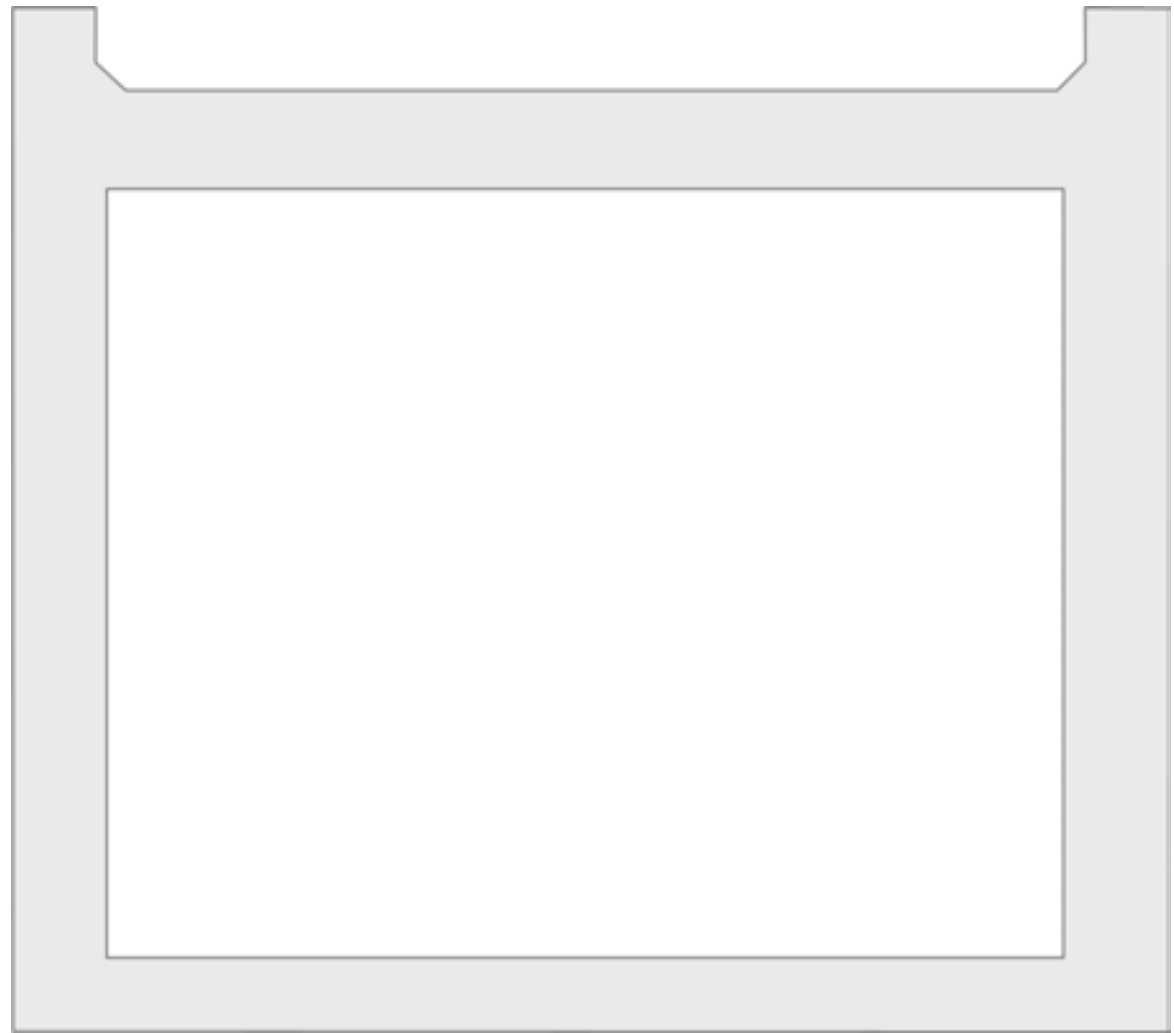



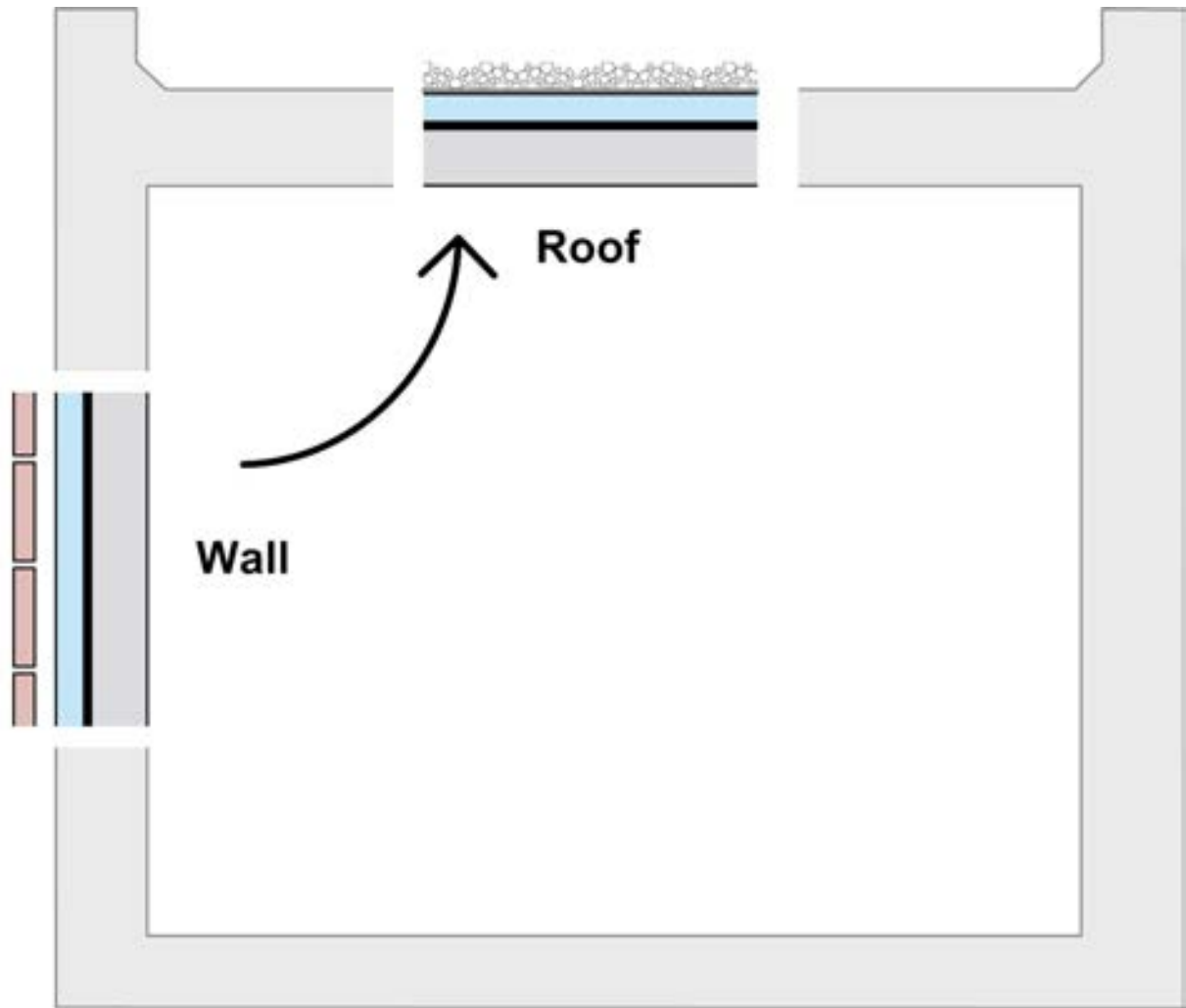

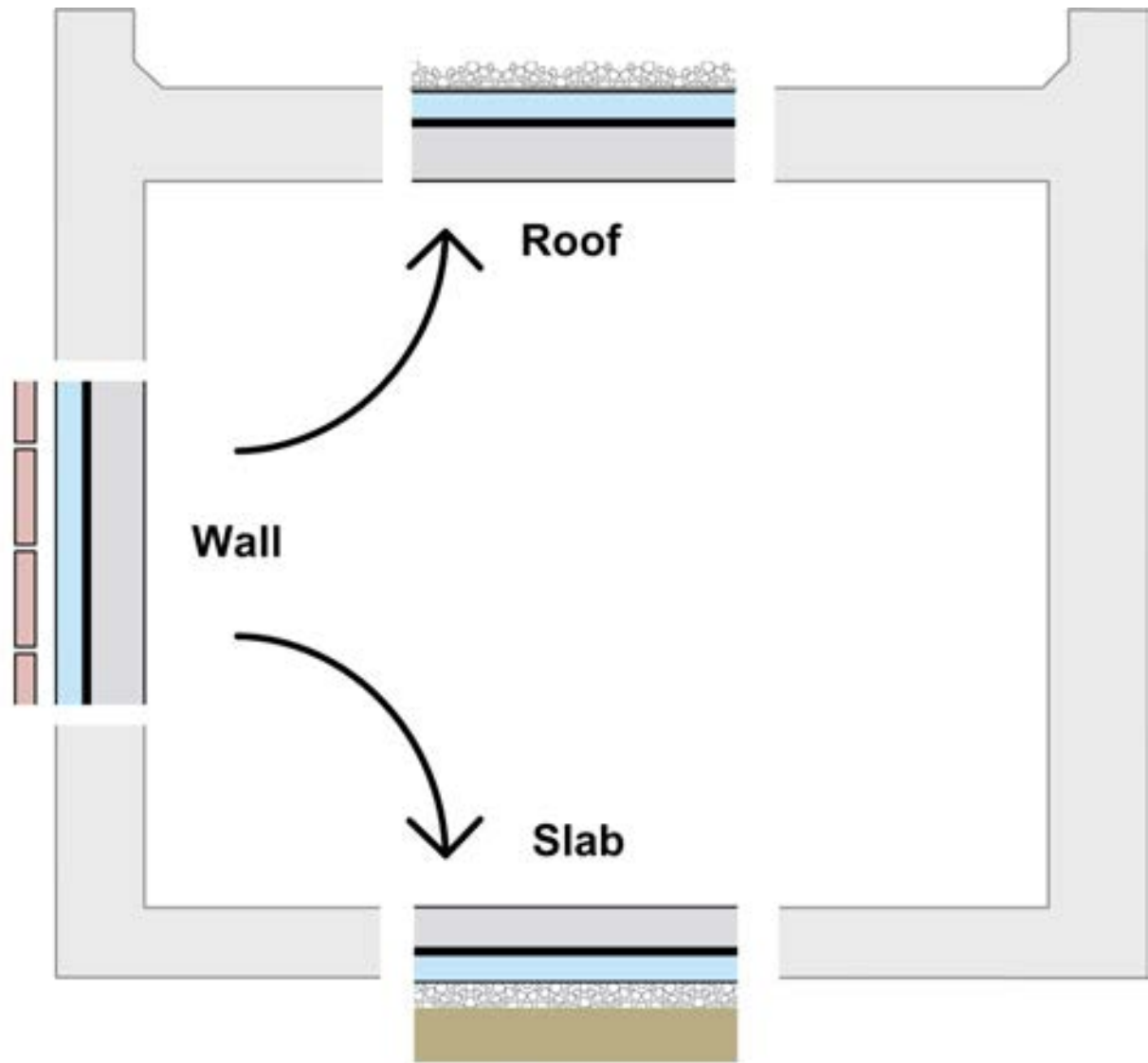

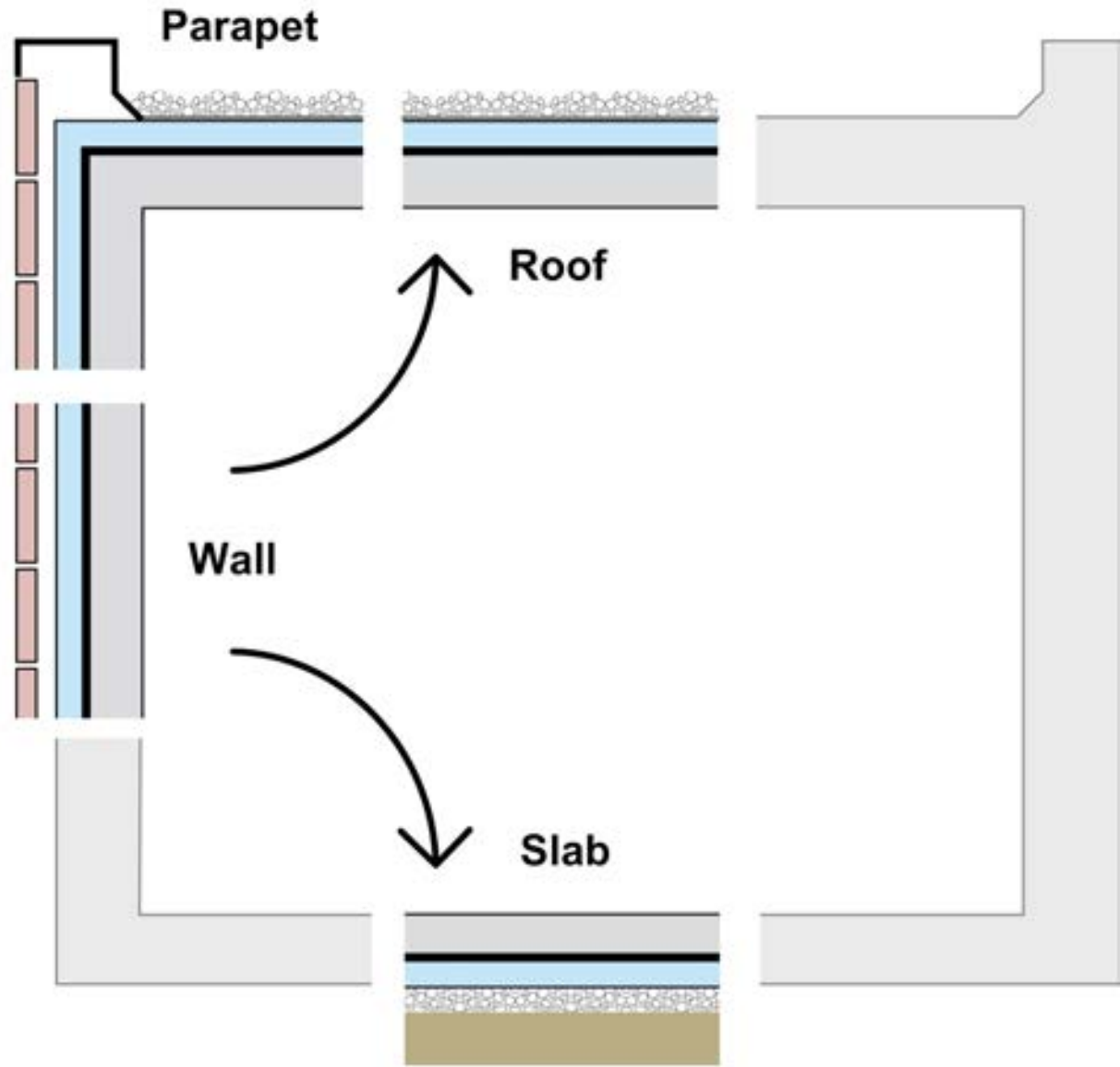

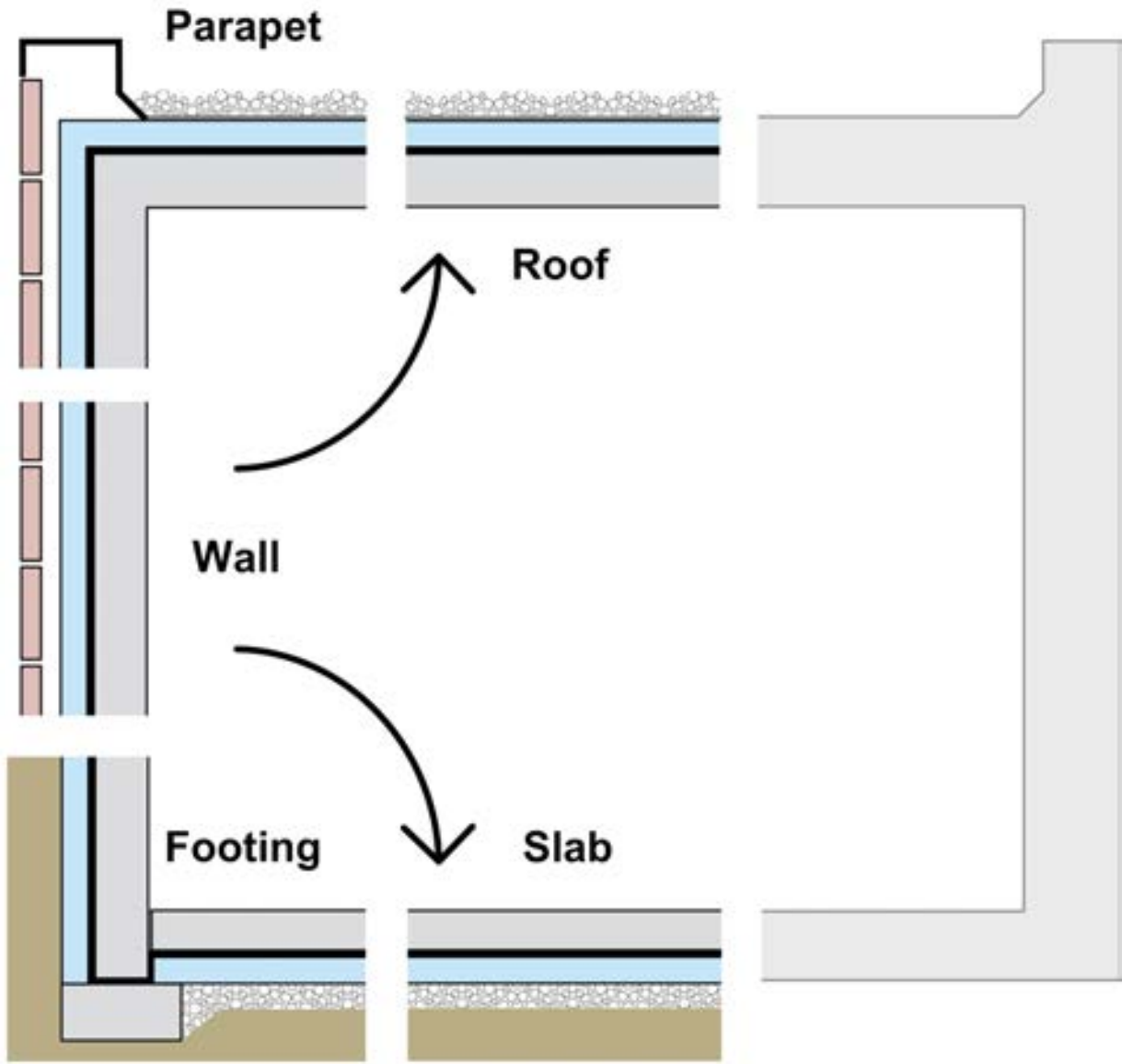

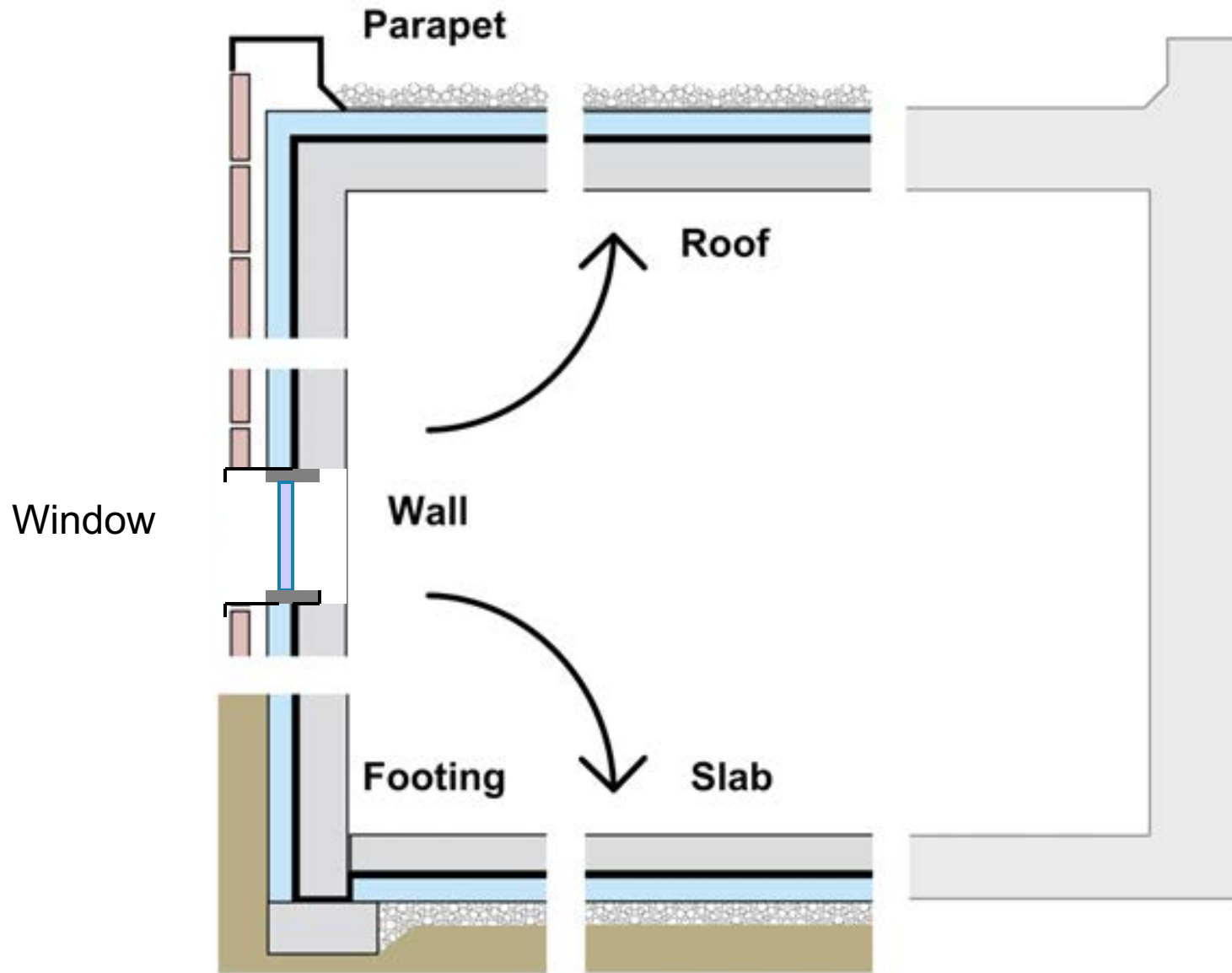





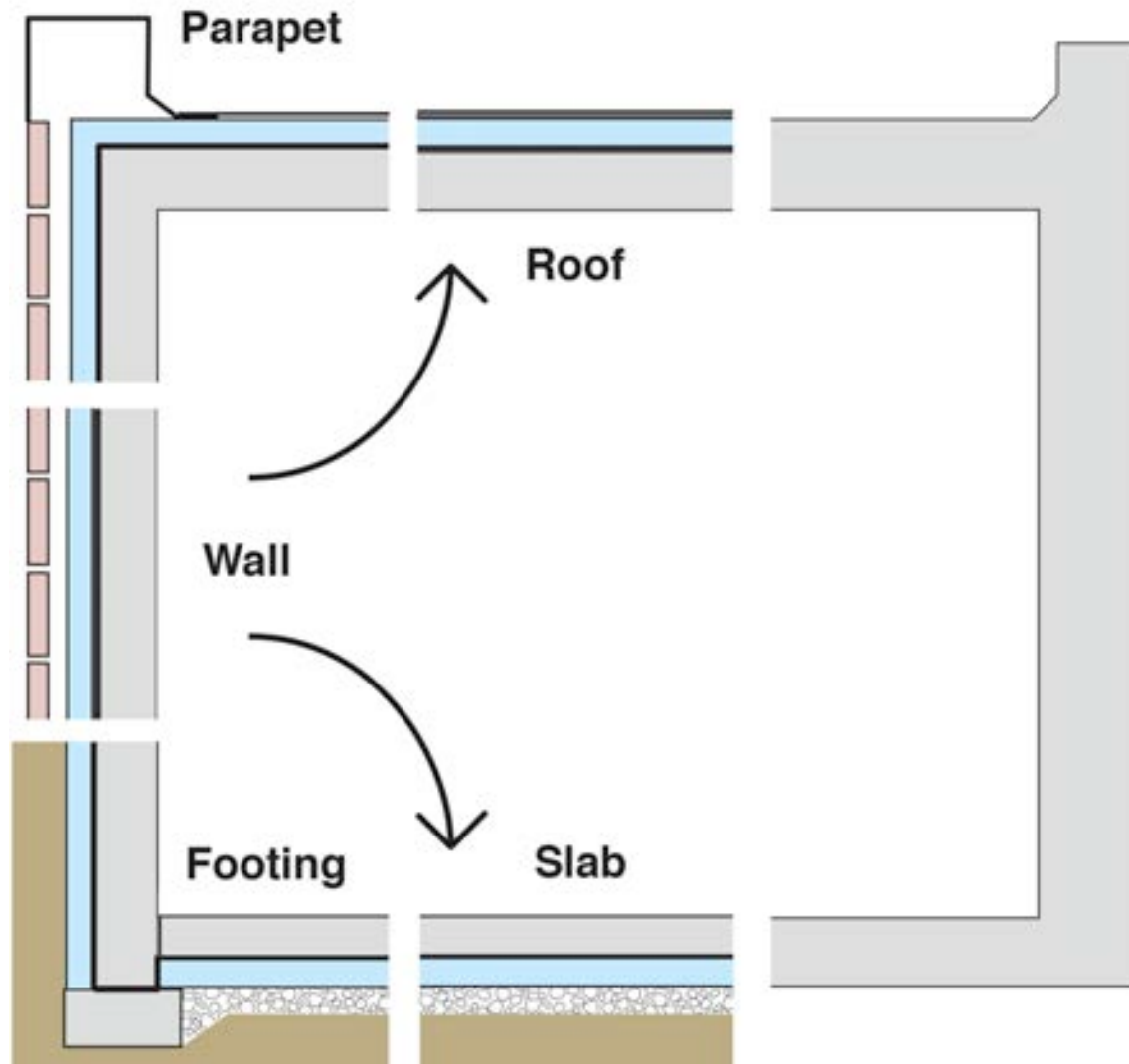

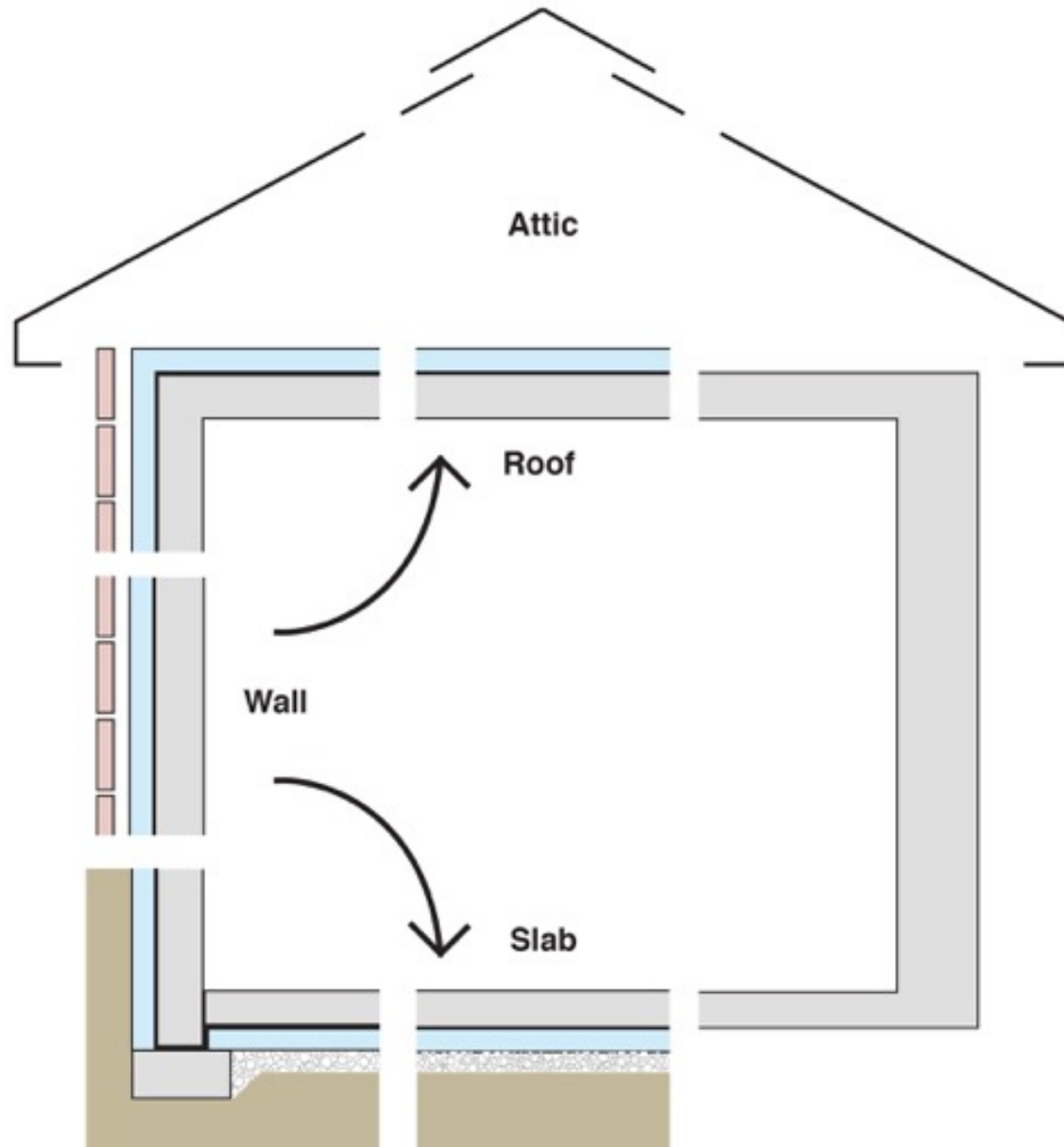

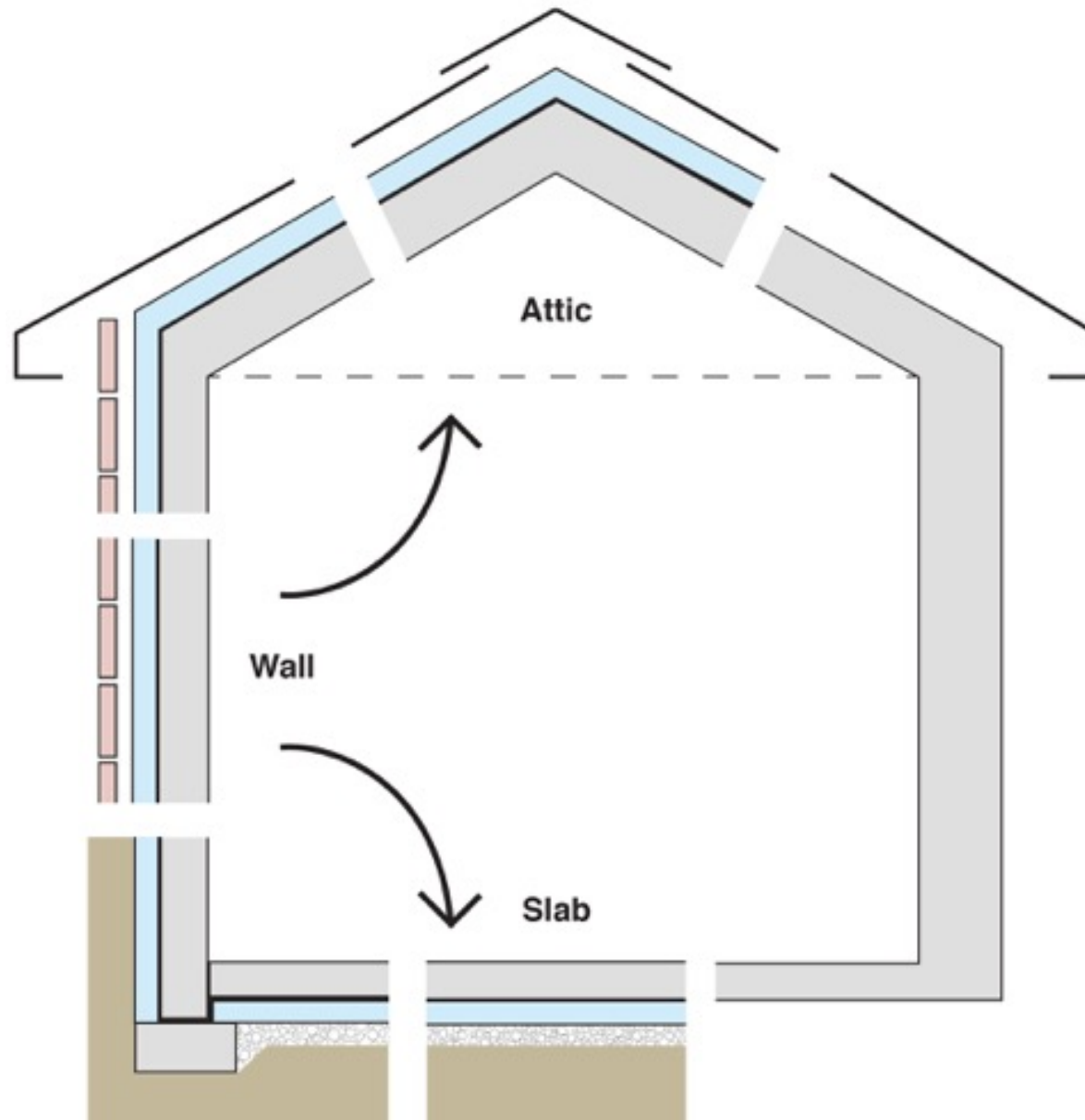

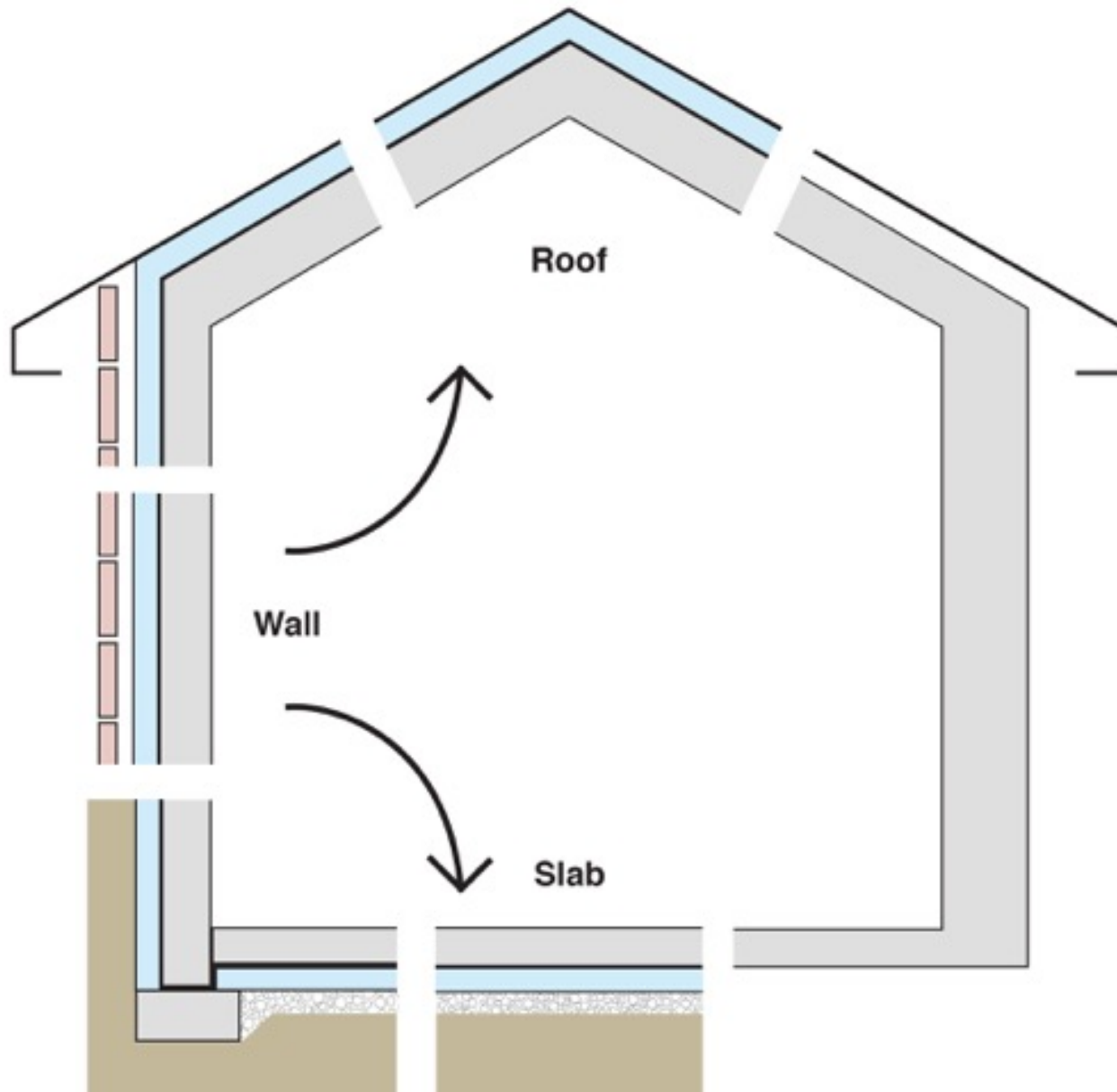

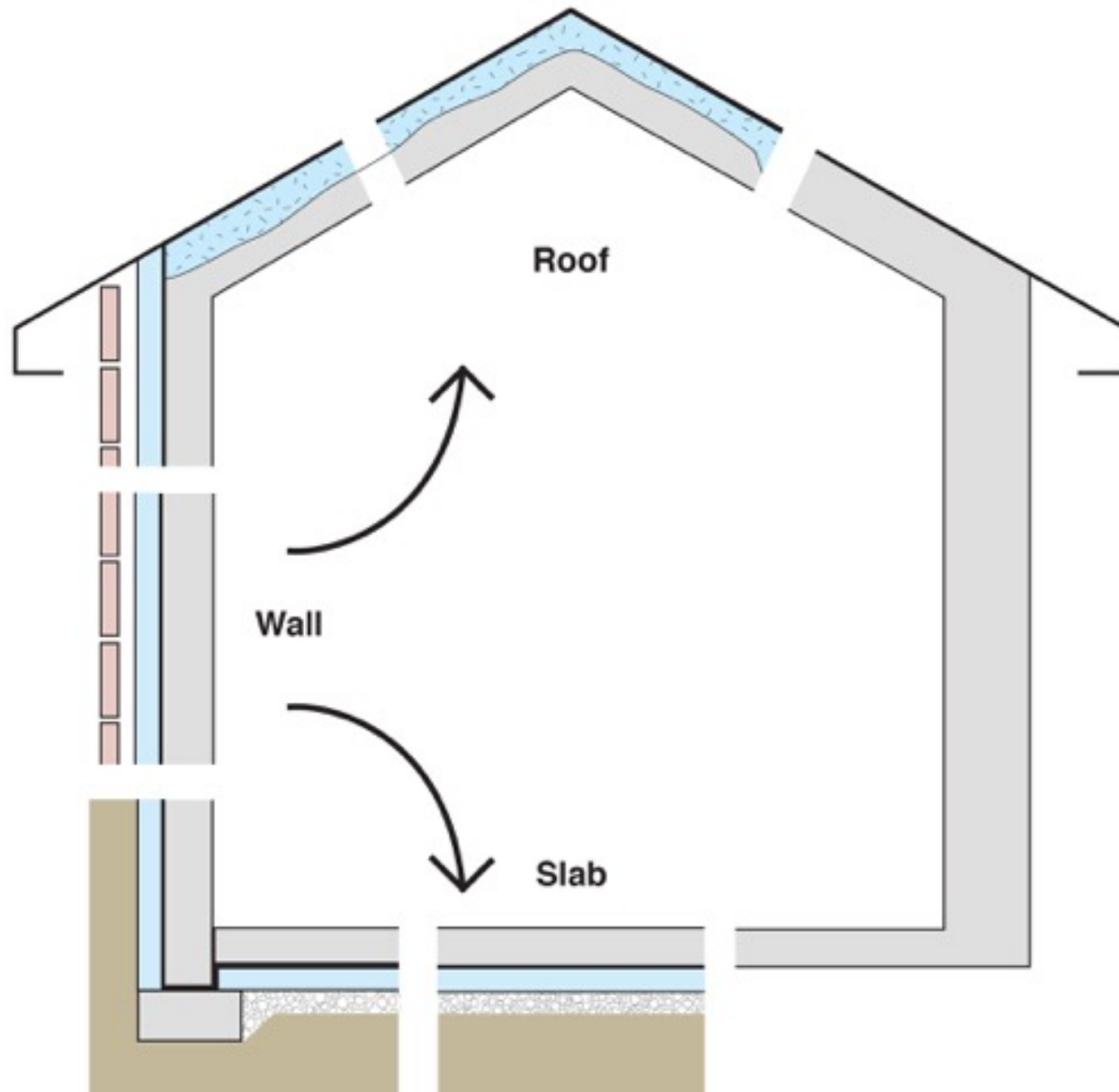

# Configurations of the Perfect Wall

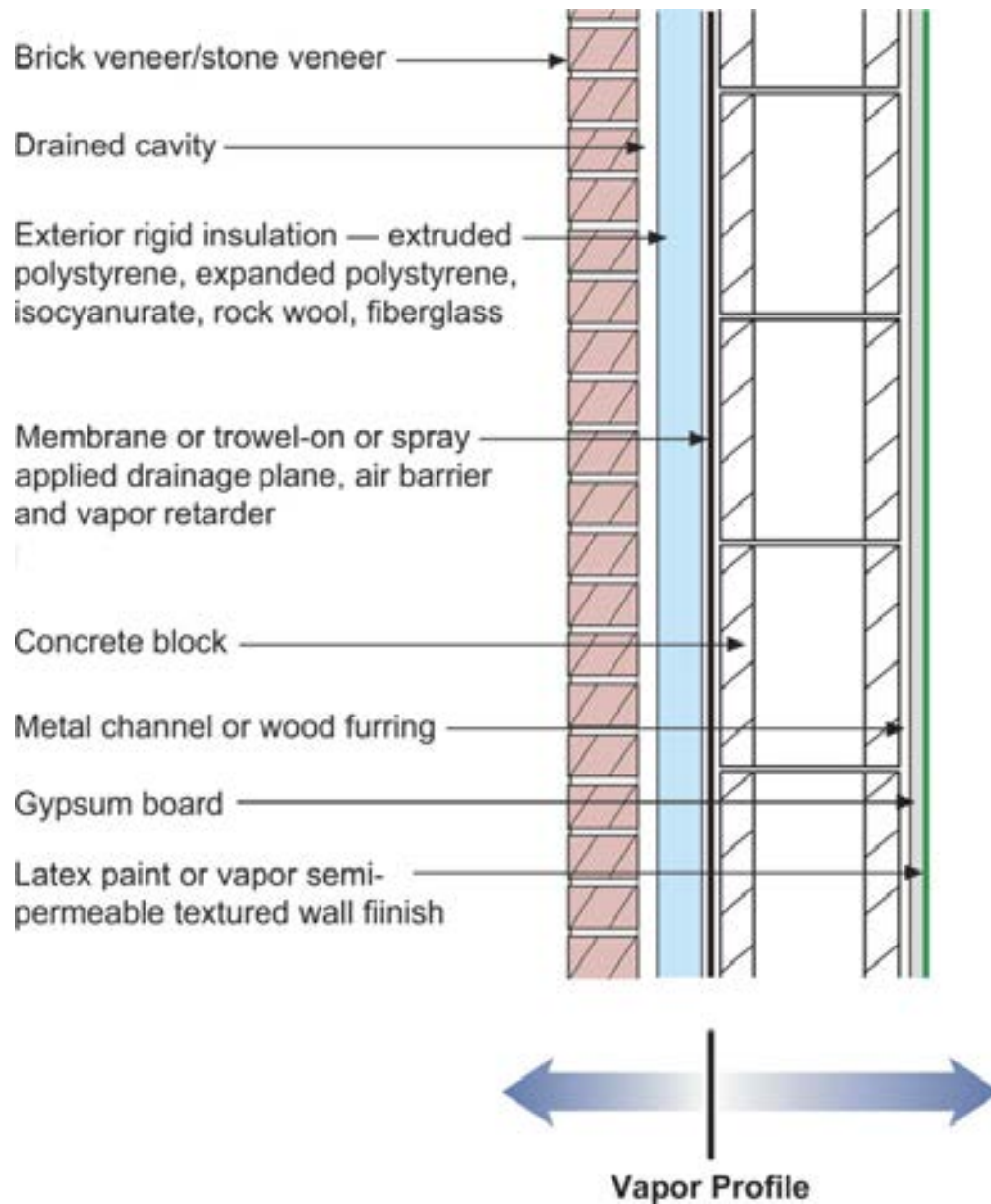



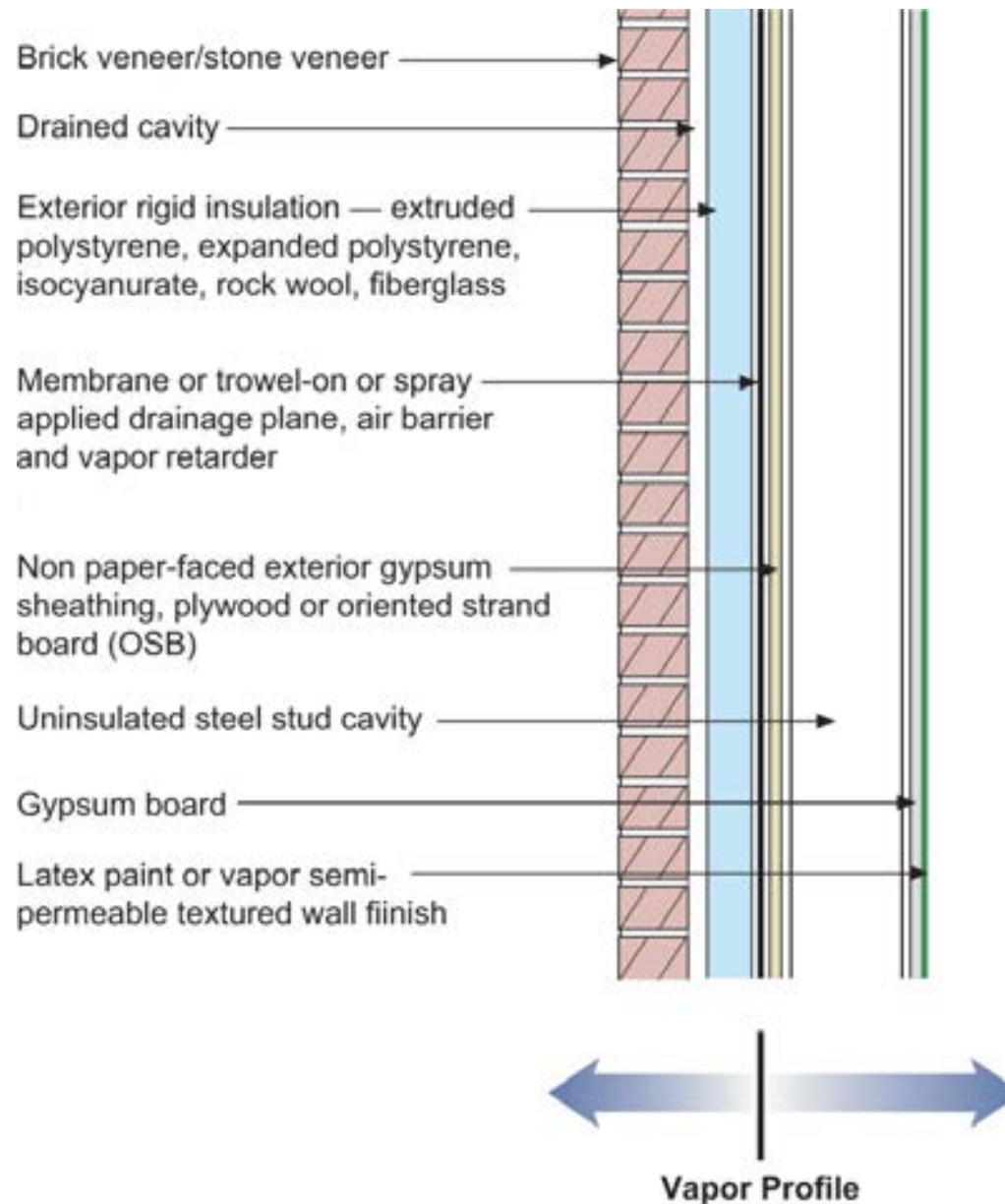

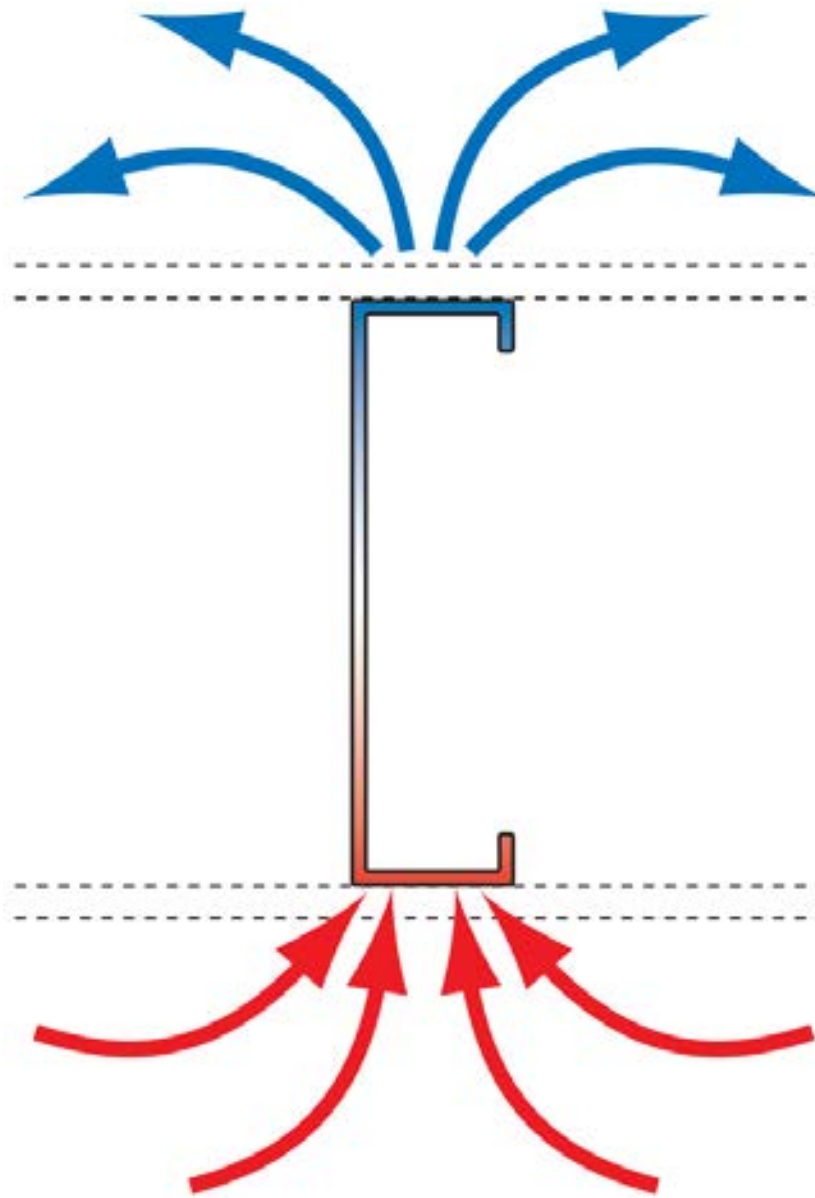



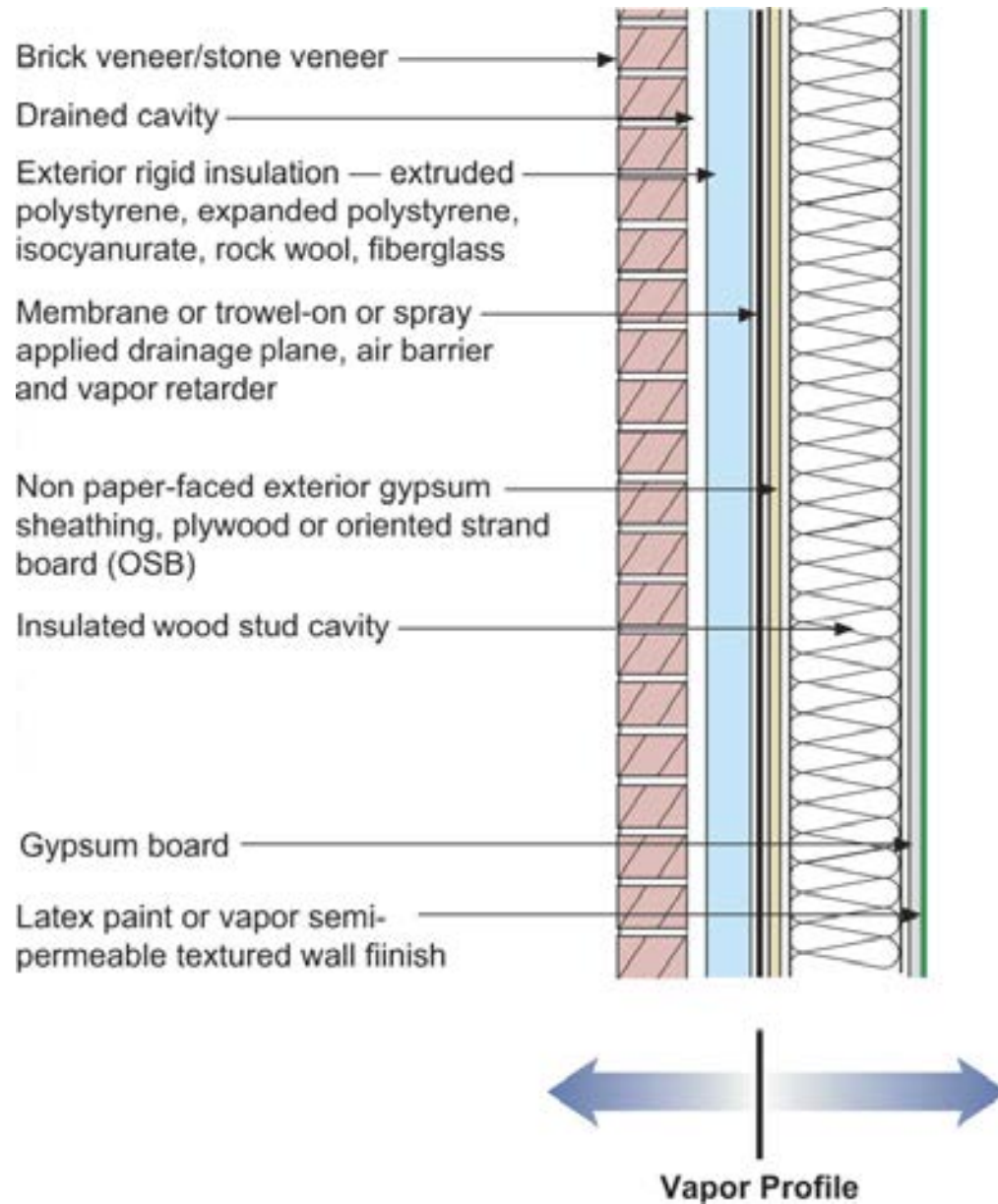

# Commercial Enclosure: Simple Layers



- Structure
- Rain/Air/Vapor
- Insulation
- Finish

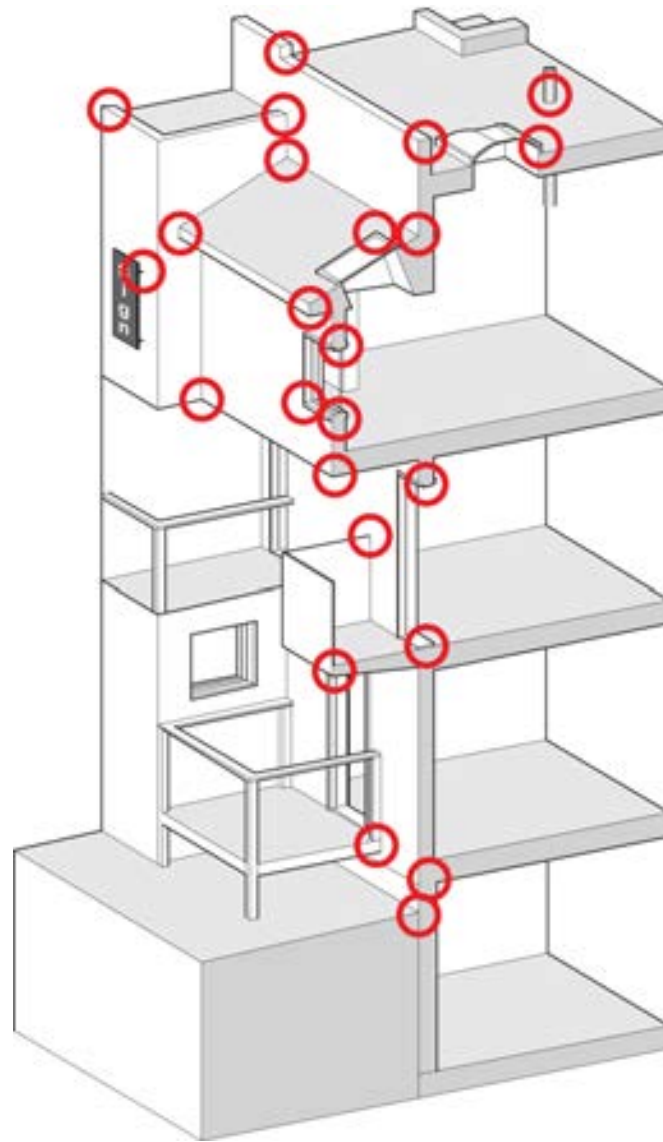





























































































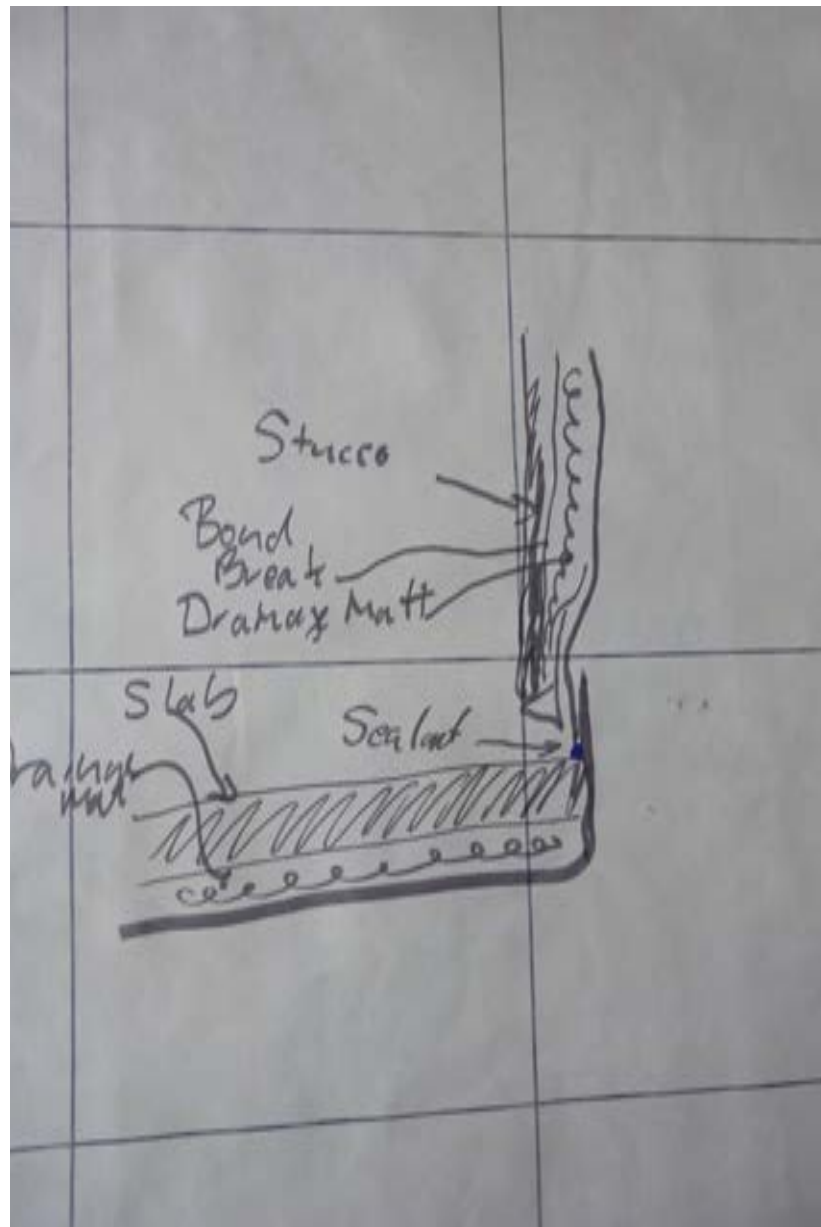























































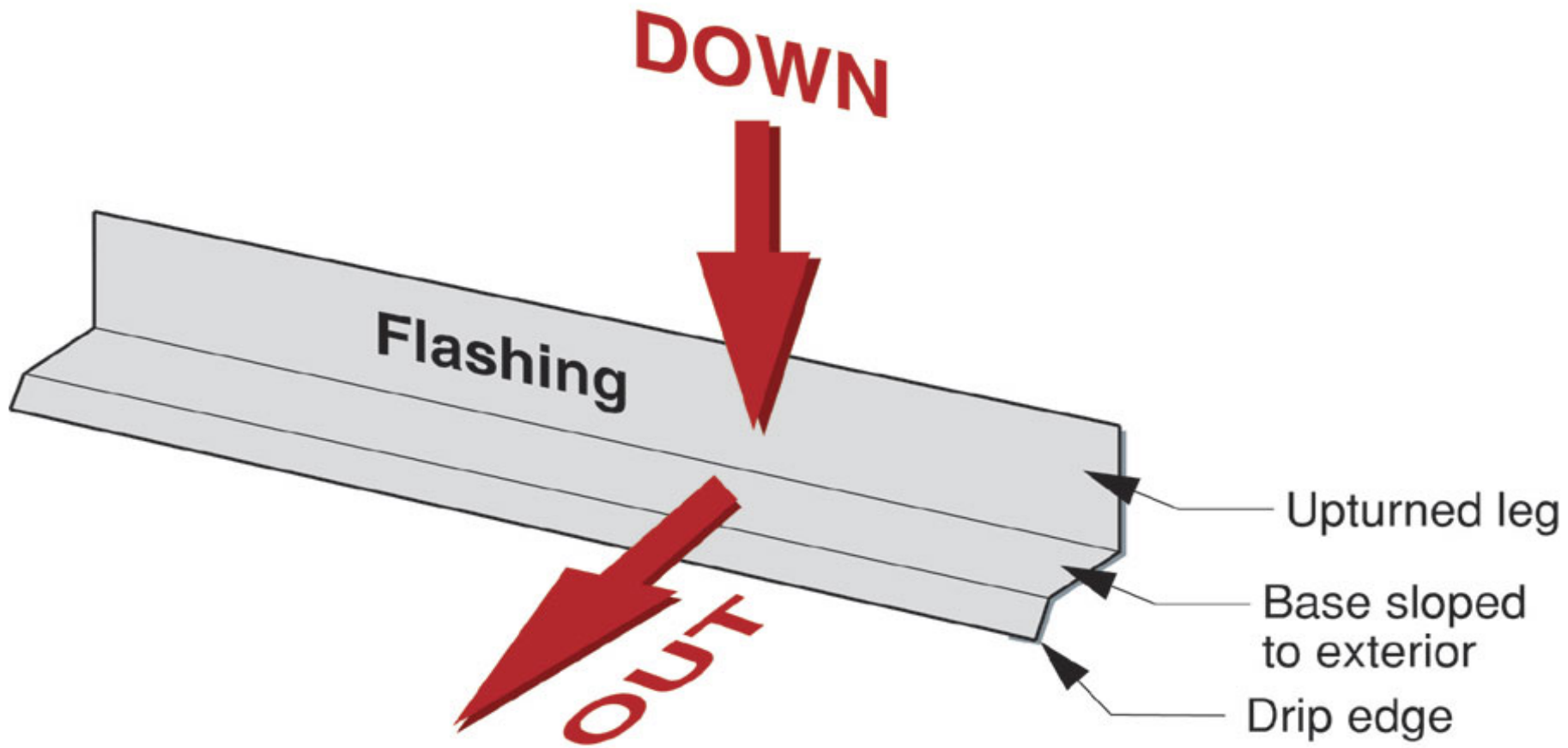

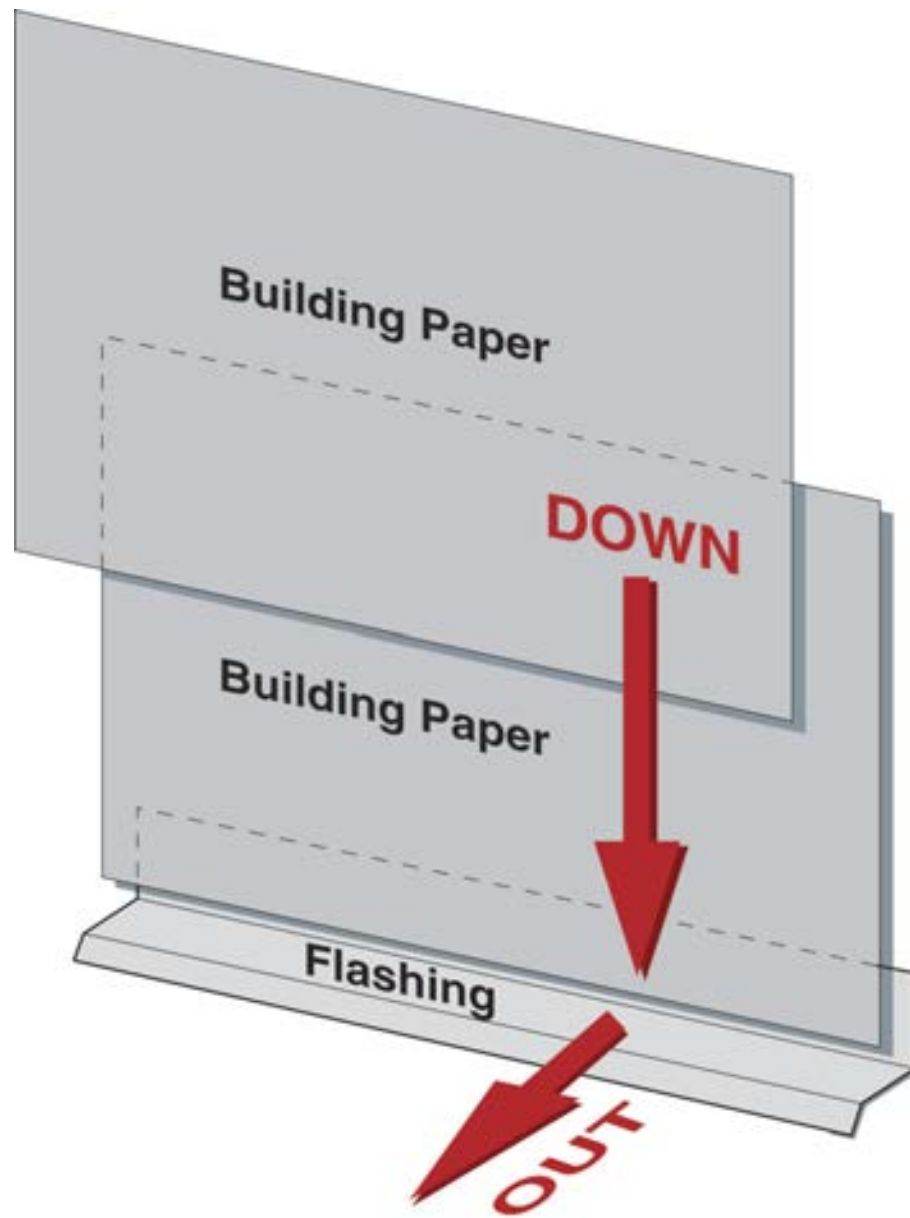

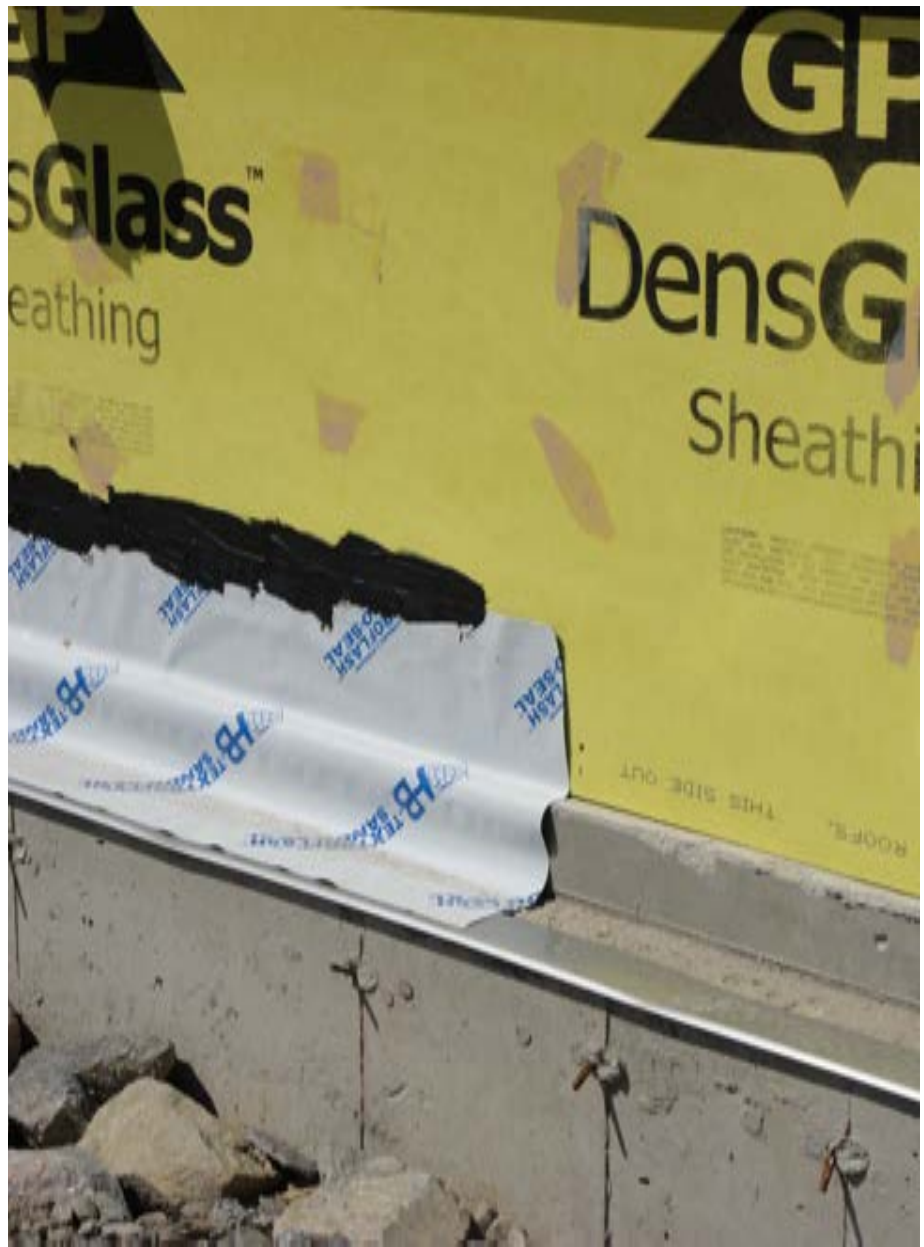





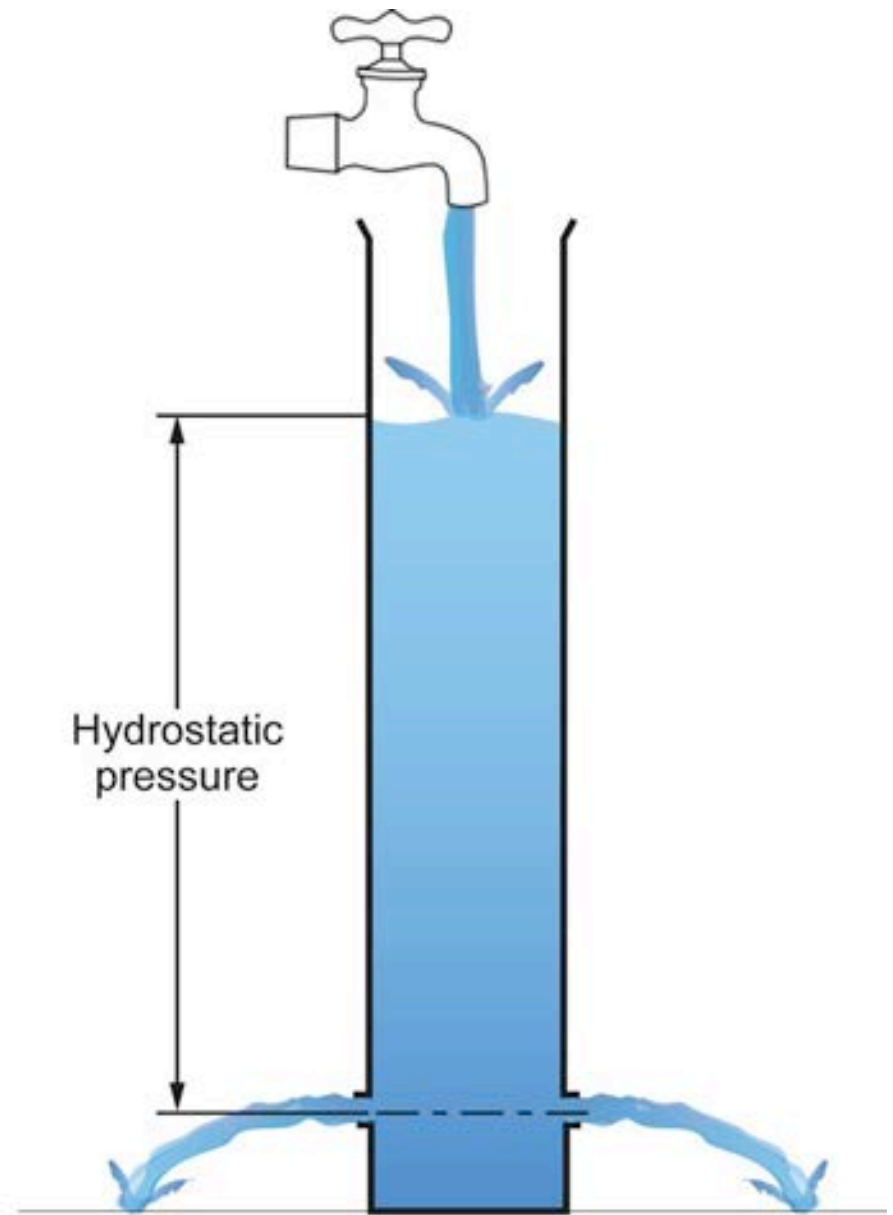
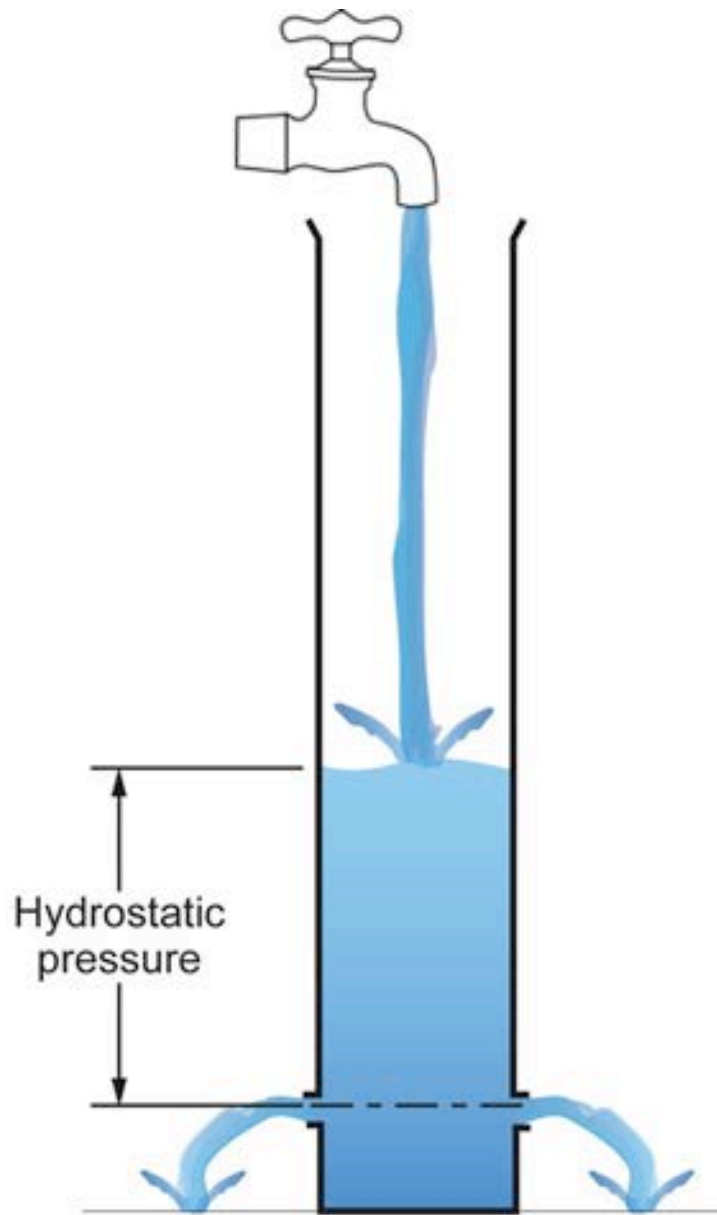



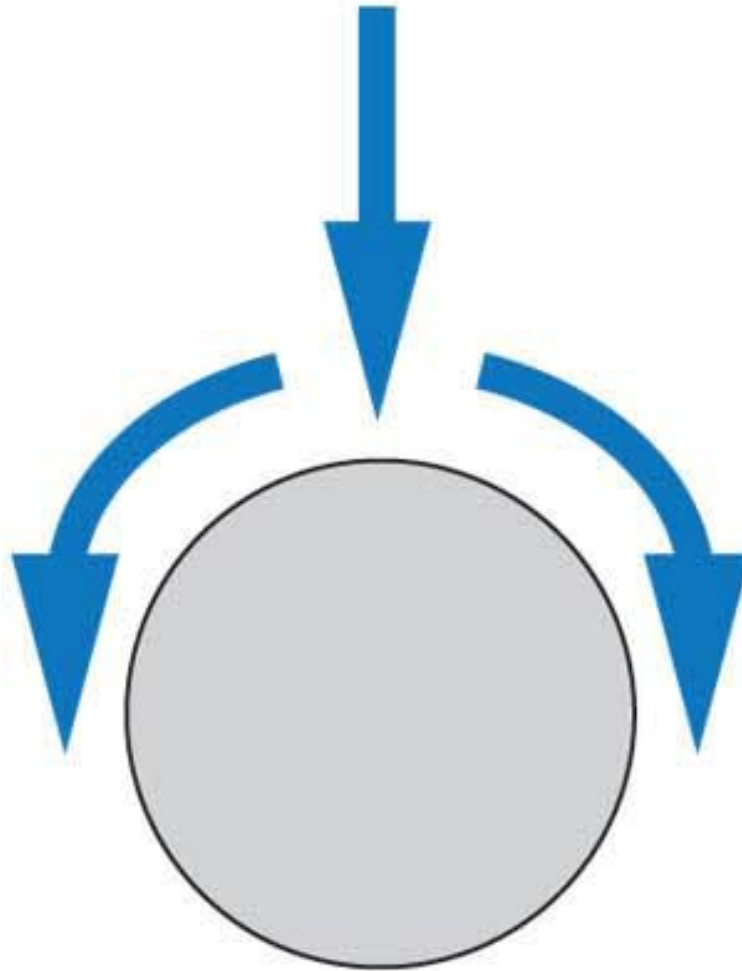

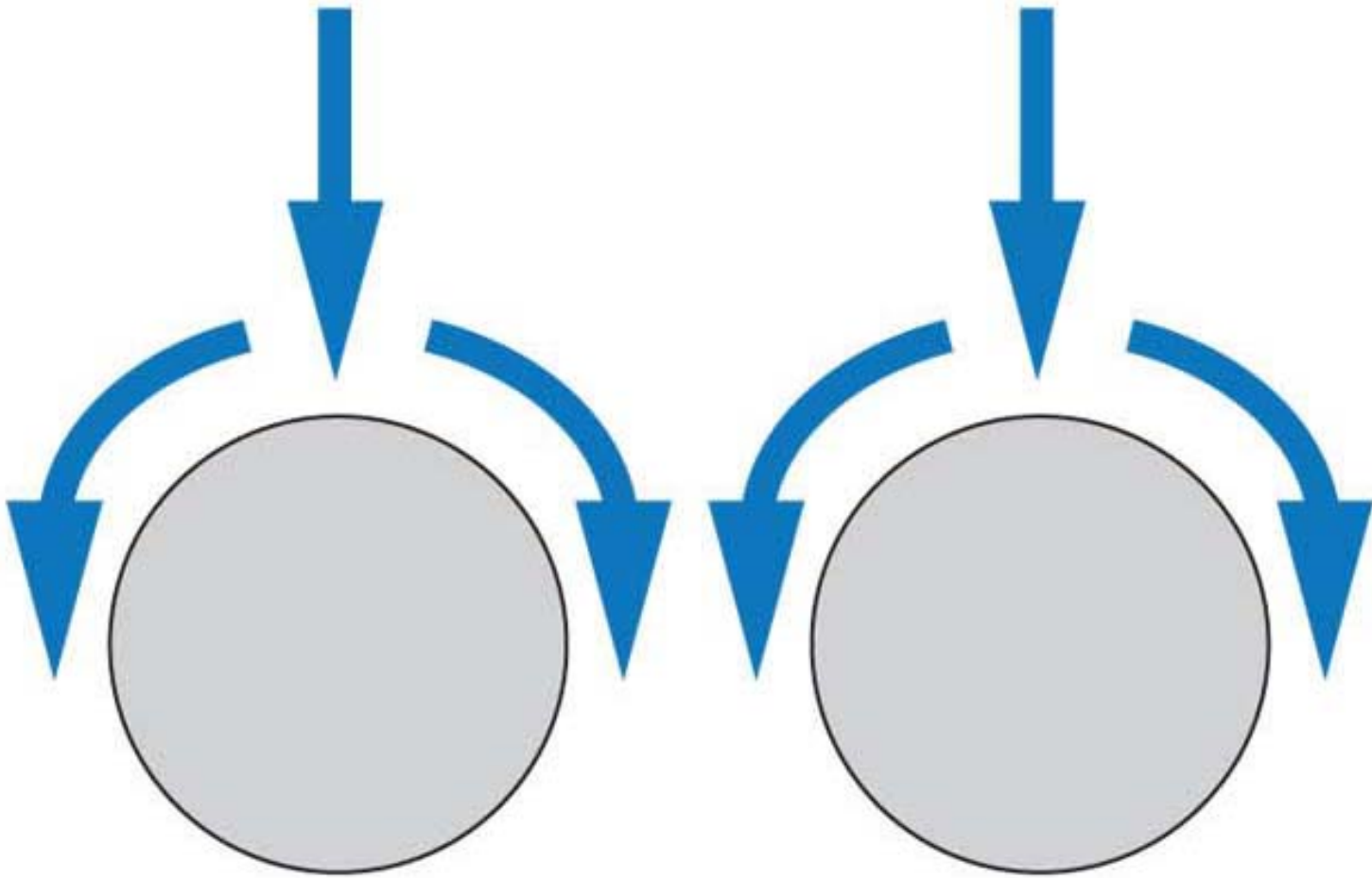



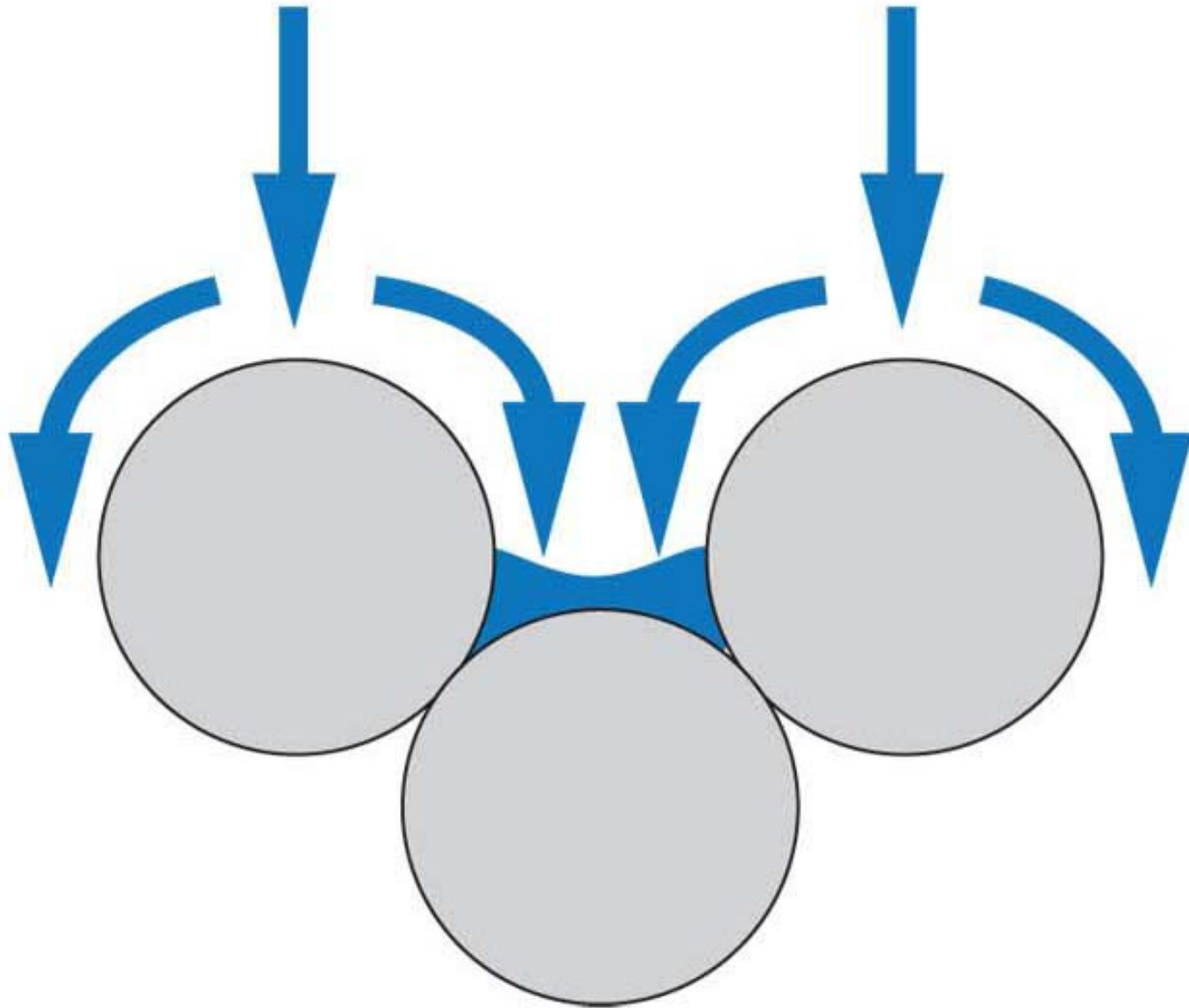



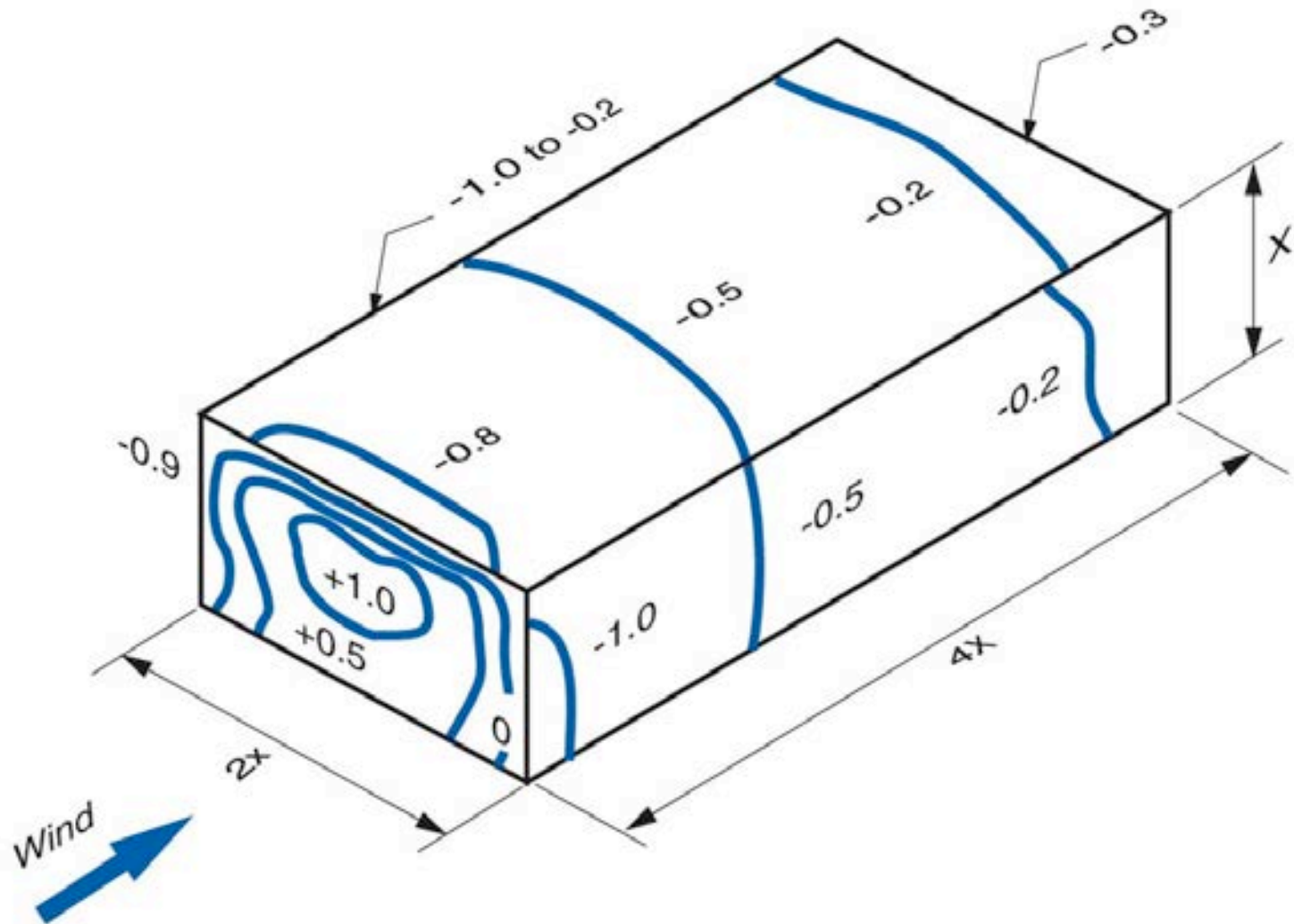

Pascals	mph
50	Pa = 20 mph
100	Pa = 30 mph
150	Pa = 35 mph
250	Pa = 45 mph
500	Pa = 65 mph
1,000	Pa = 90 mph

Wind Speed (mph) vs. Stagnation Pressure (Pa)

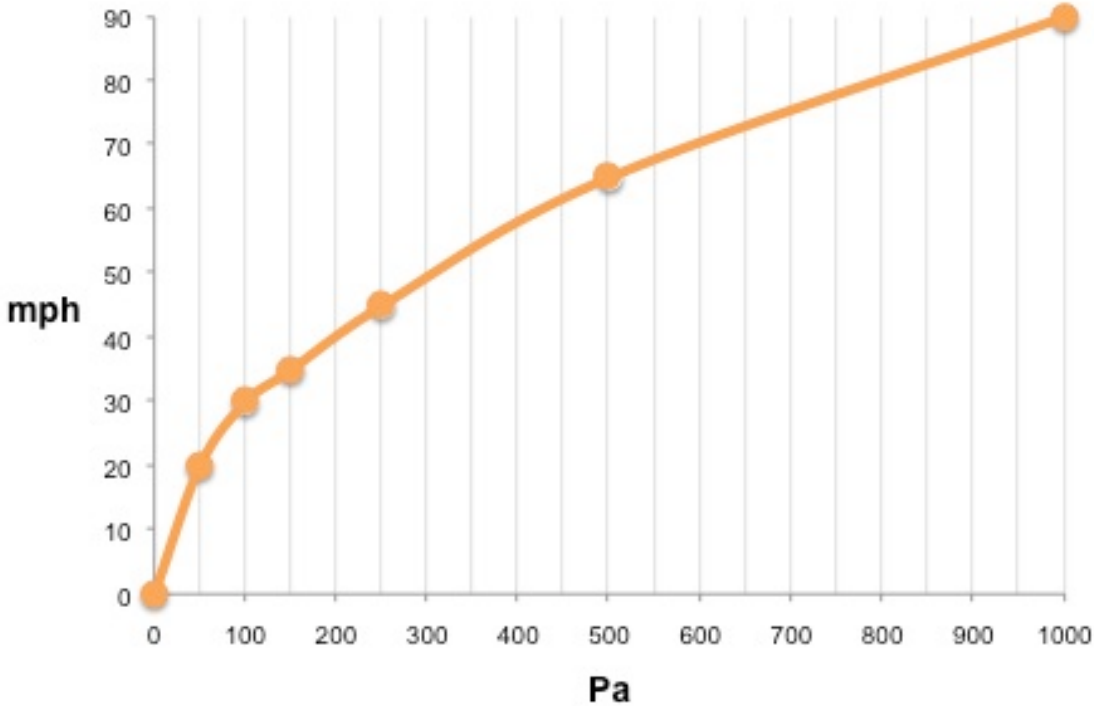









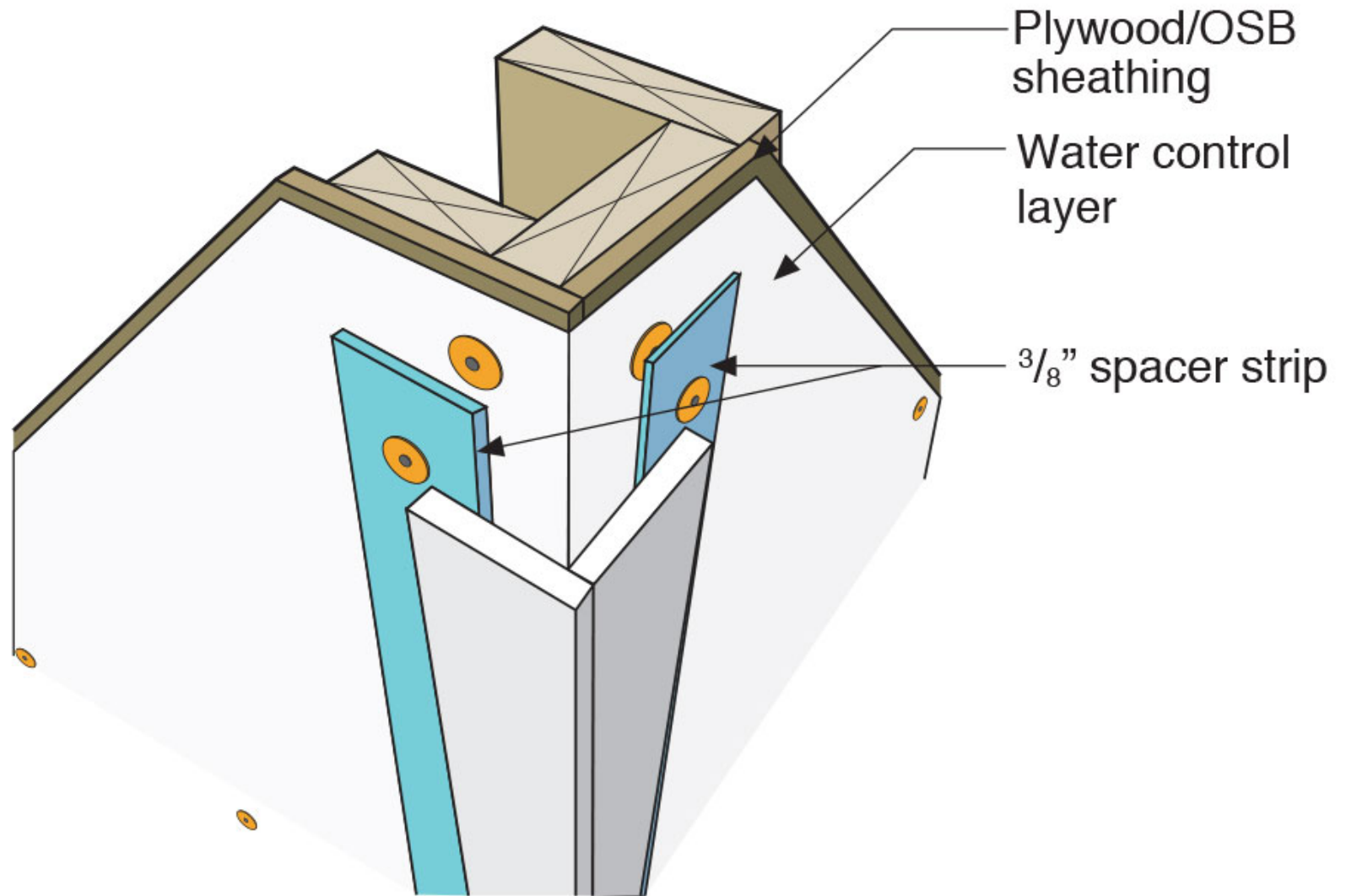

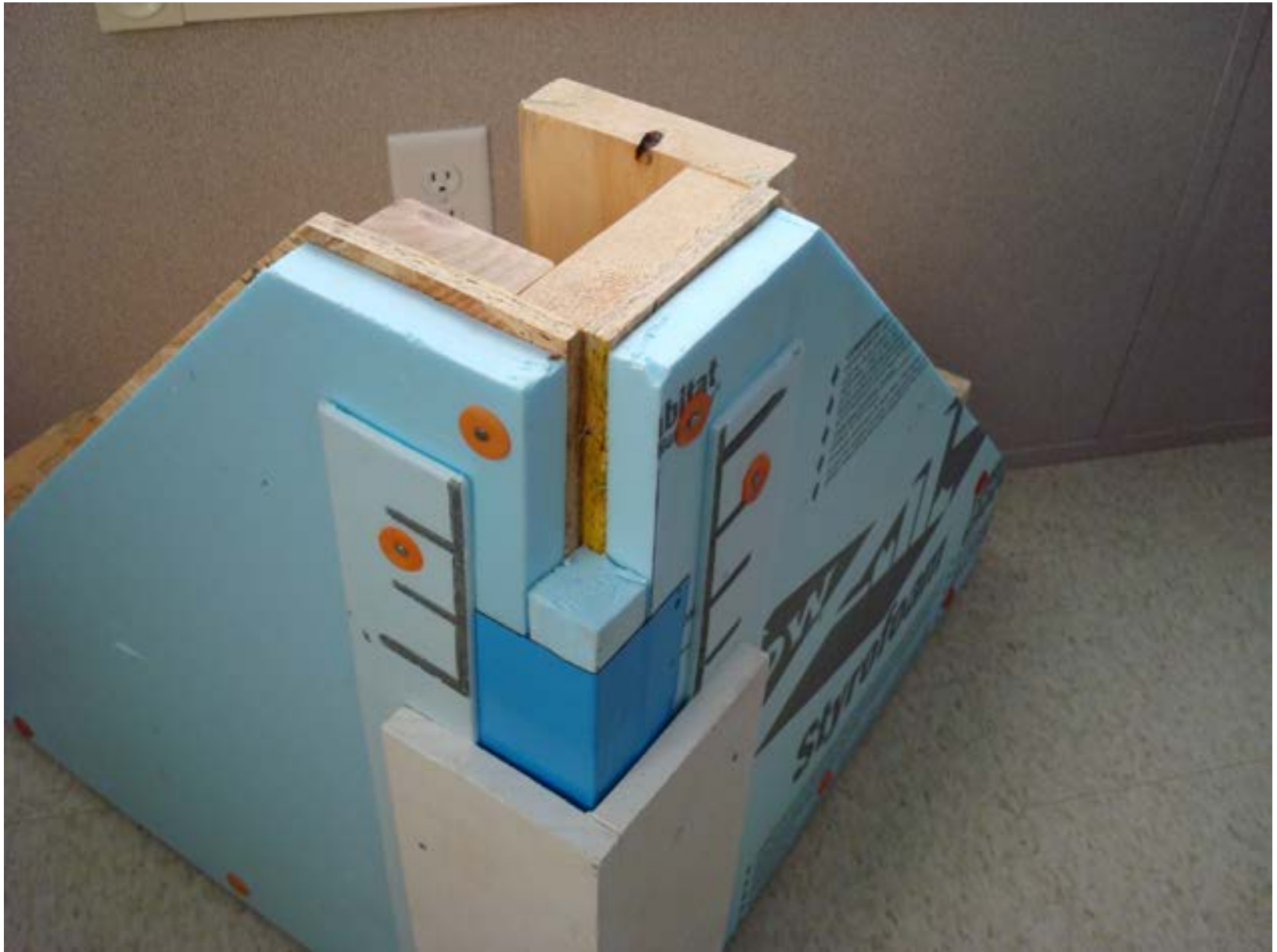









# Rain Screen

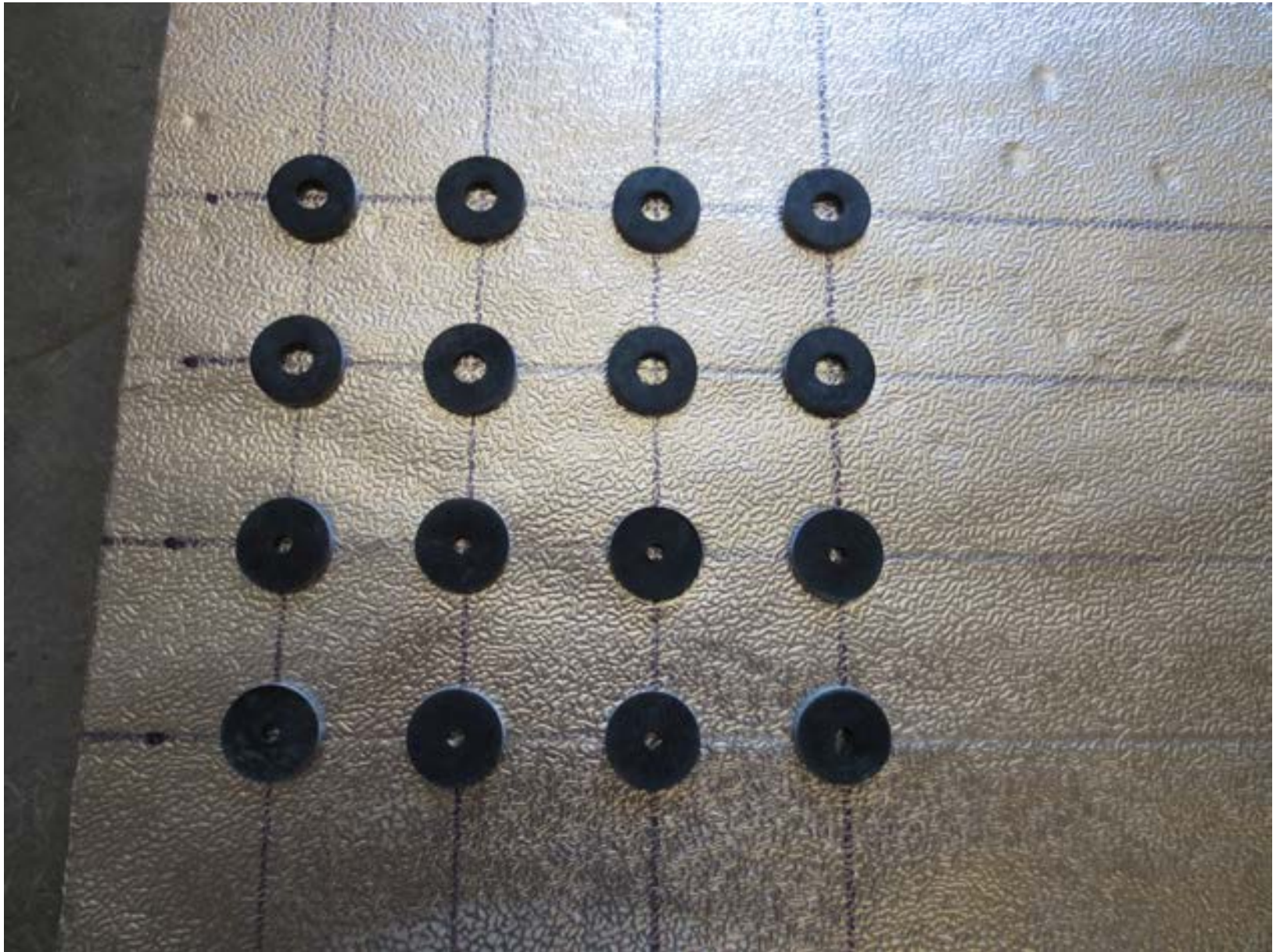

# Beer Screen?

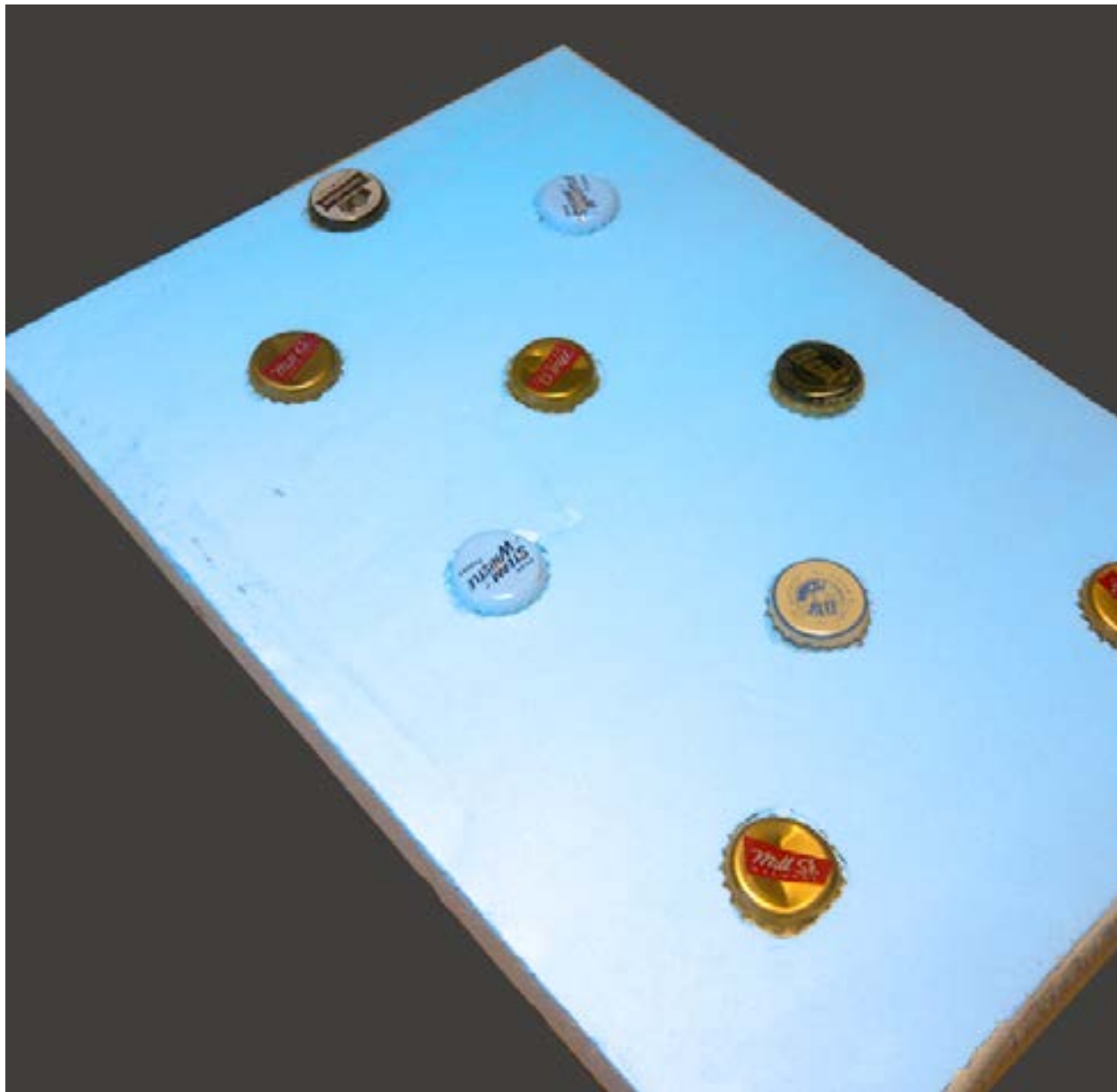

Rain enters cup  
due to momentum  
("kinetic energy")

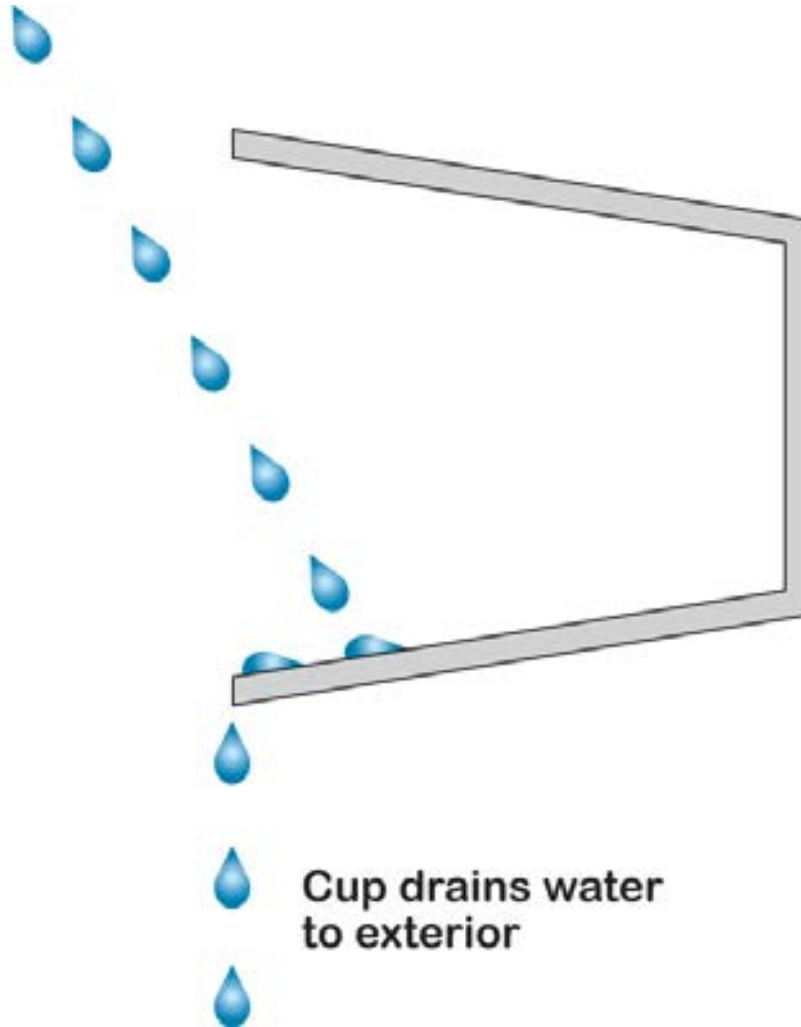

Cup drains water  
to exterior



Rain enters cup due to momentum ("kinetic energy")

Wind enters cup—pressurizing cup; no rain entry due to wind driven rain

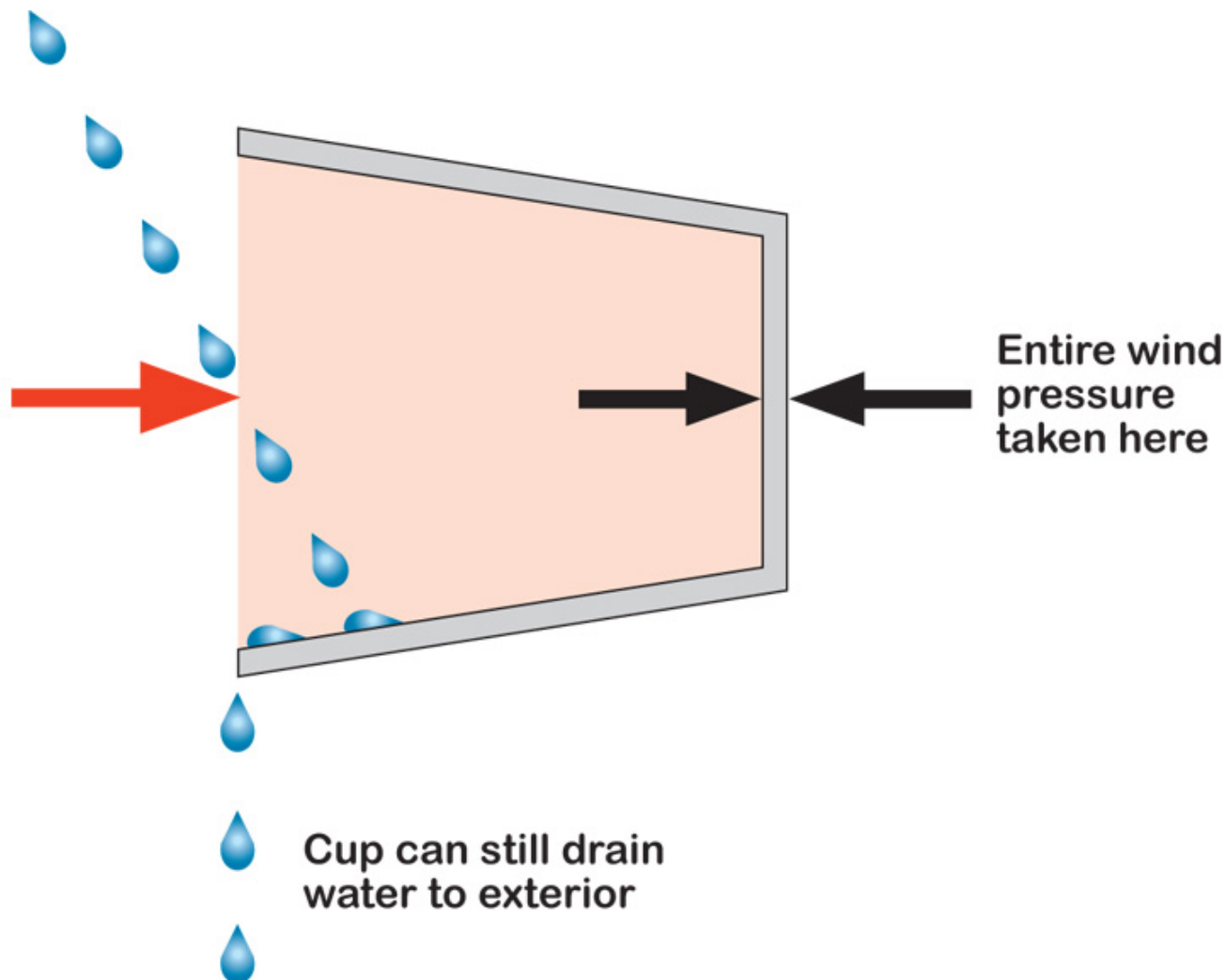

Entire wind pressure taken here

Cup can still drain water to exterior

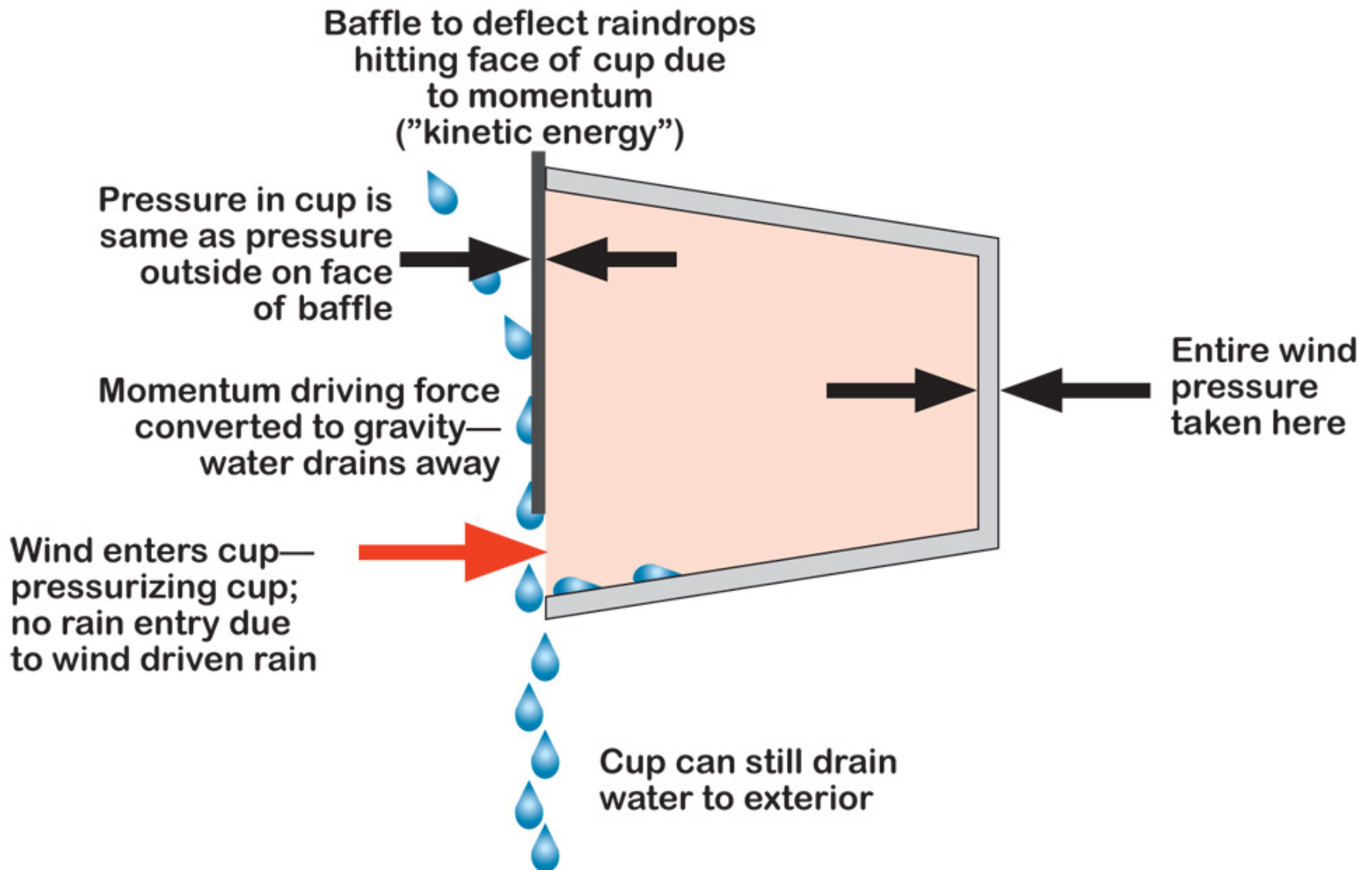

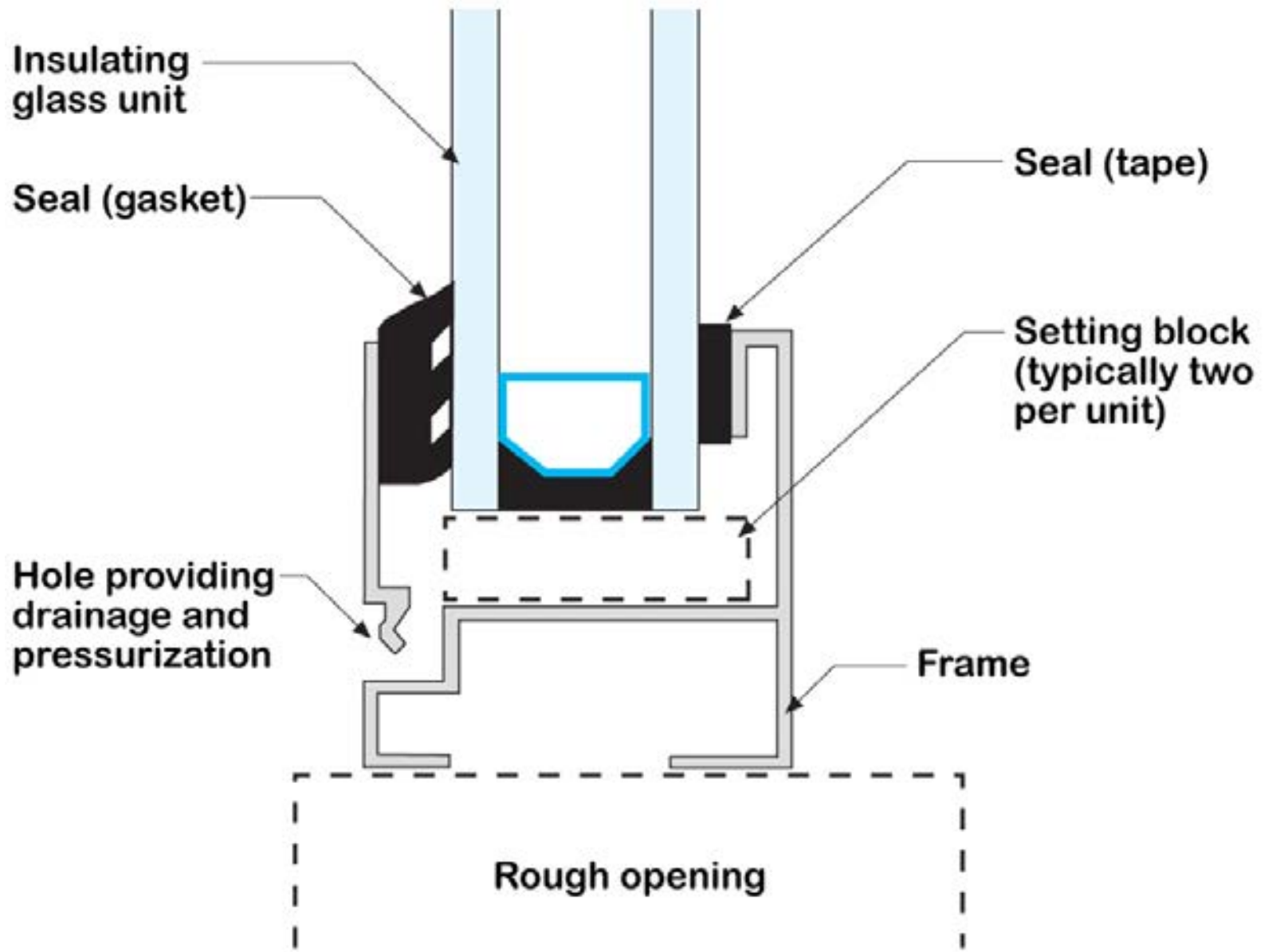

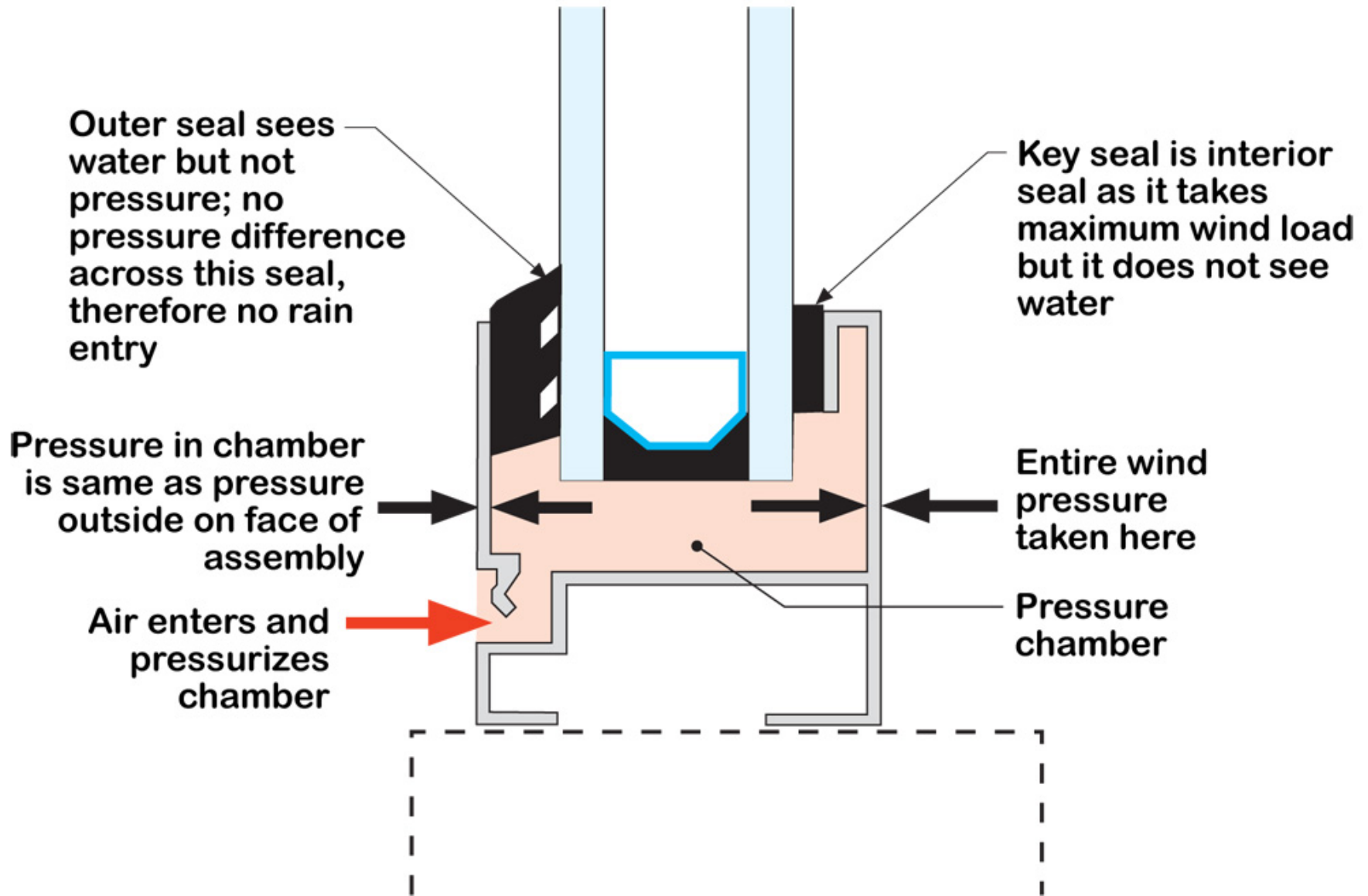

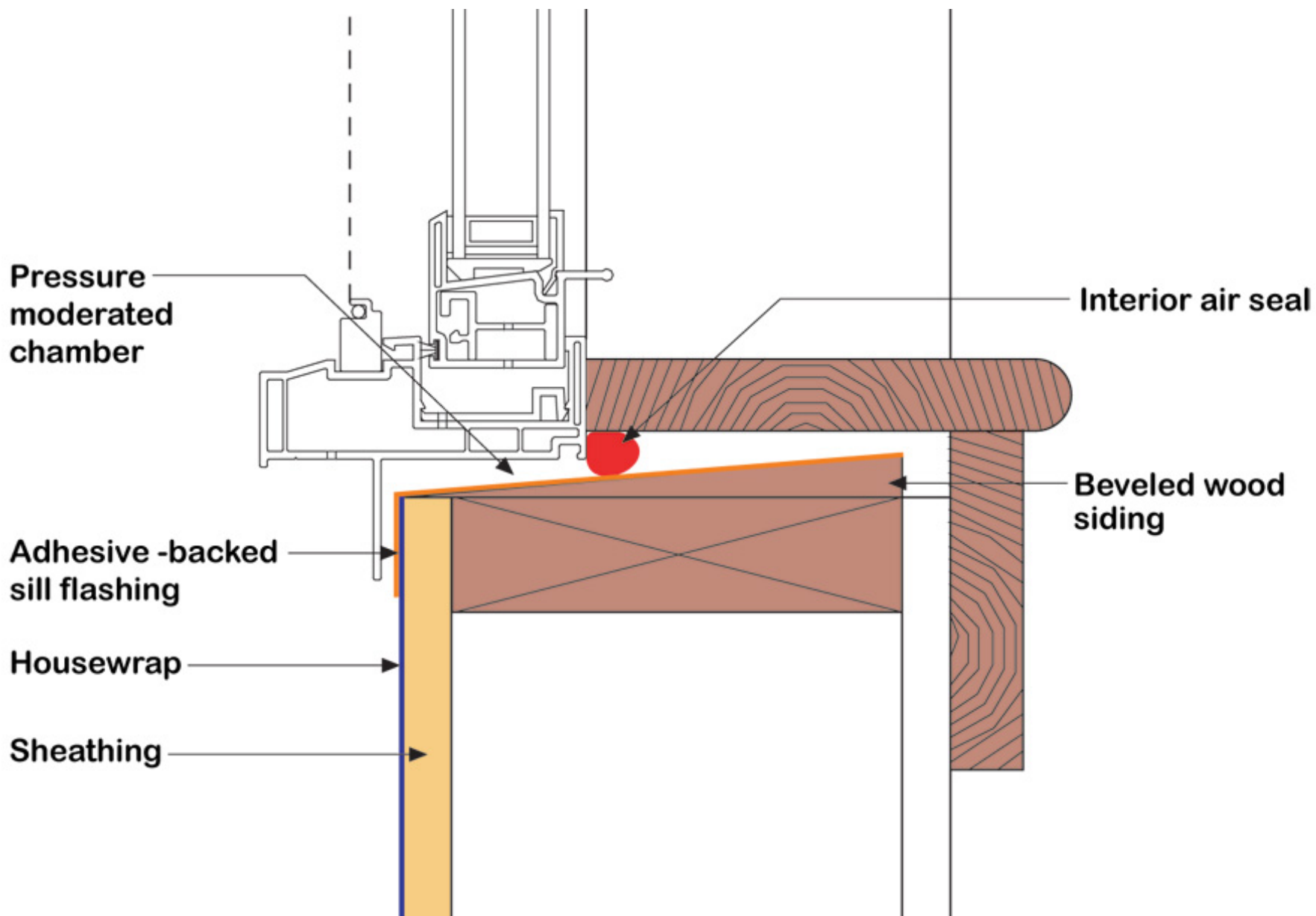

















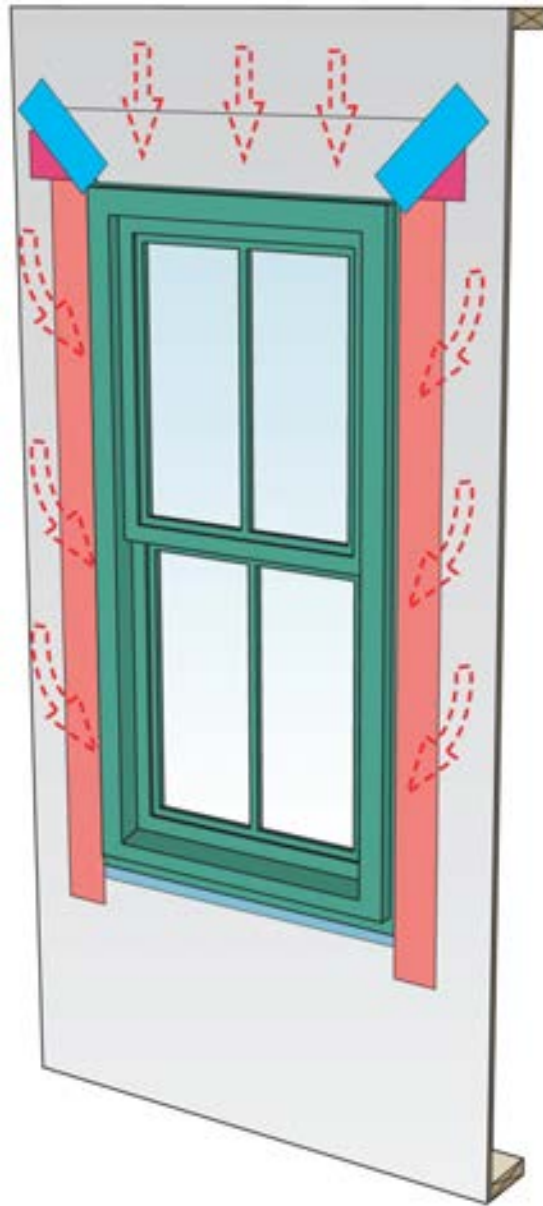

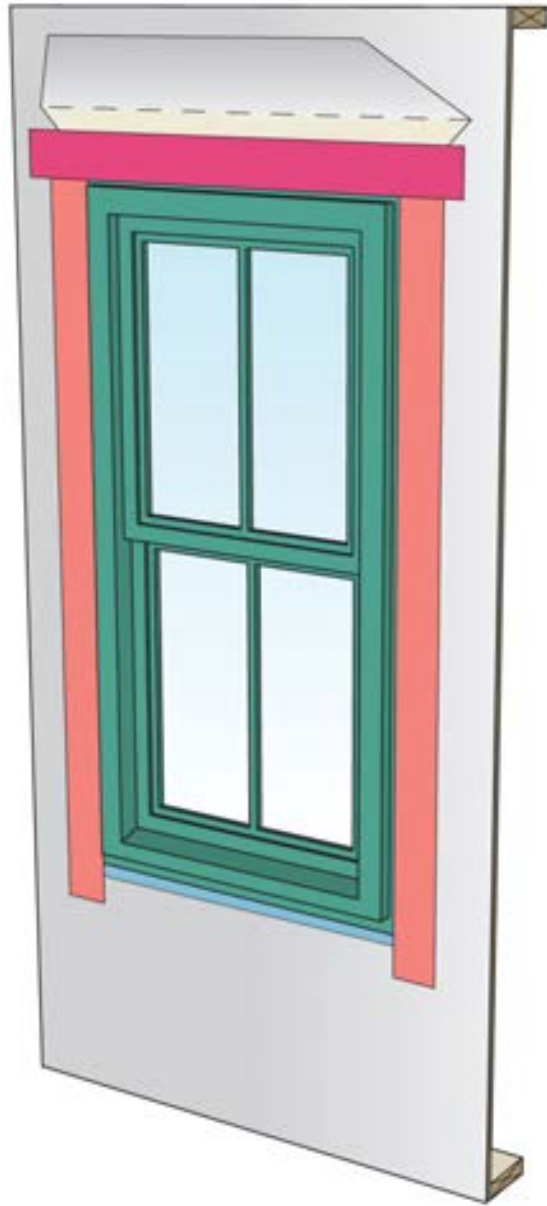

Intent of sealant is to limit this lateral flow of water between sheathing and building wrap

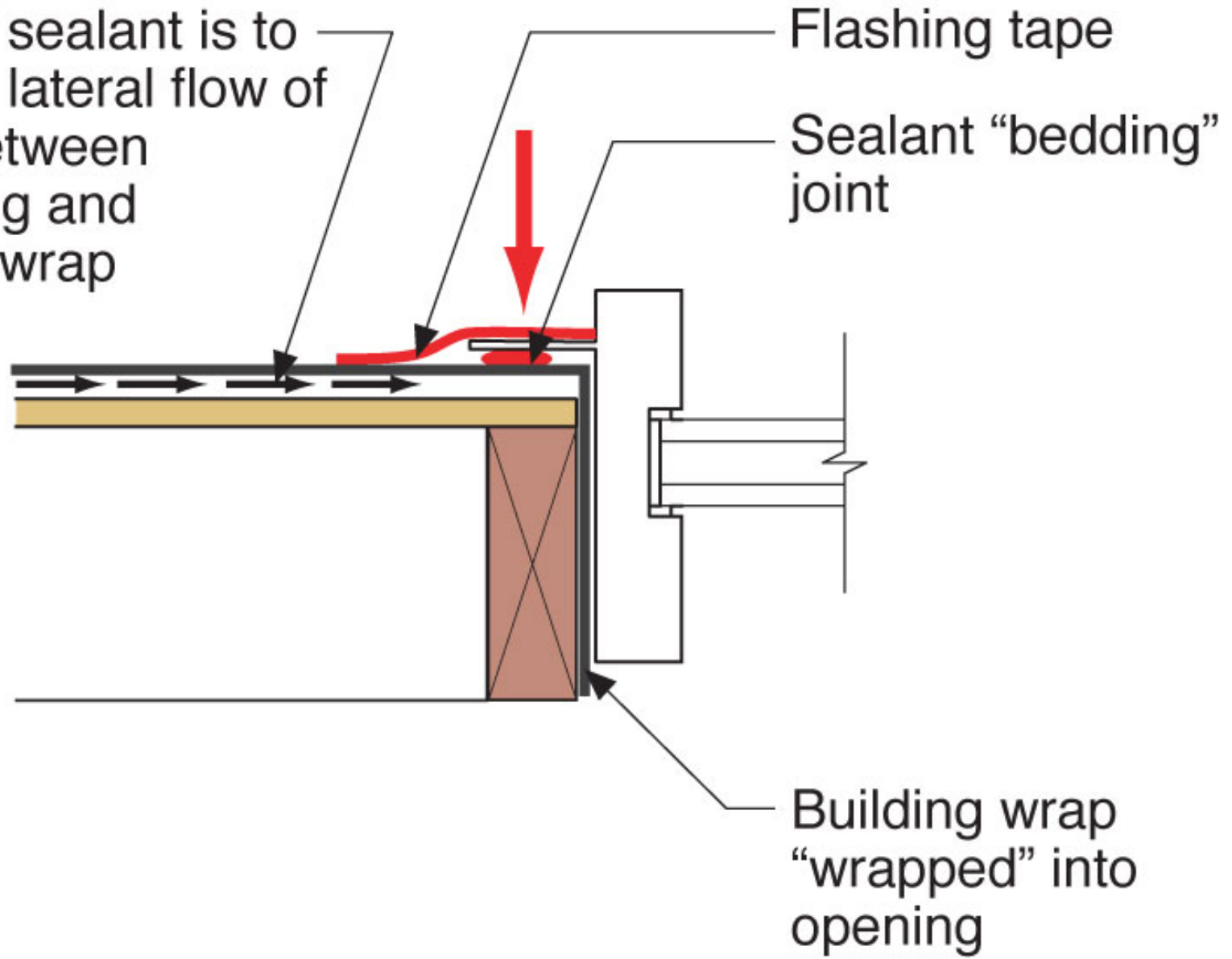

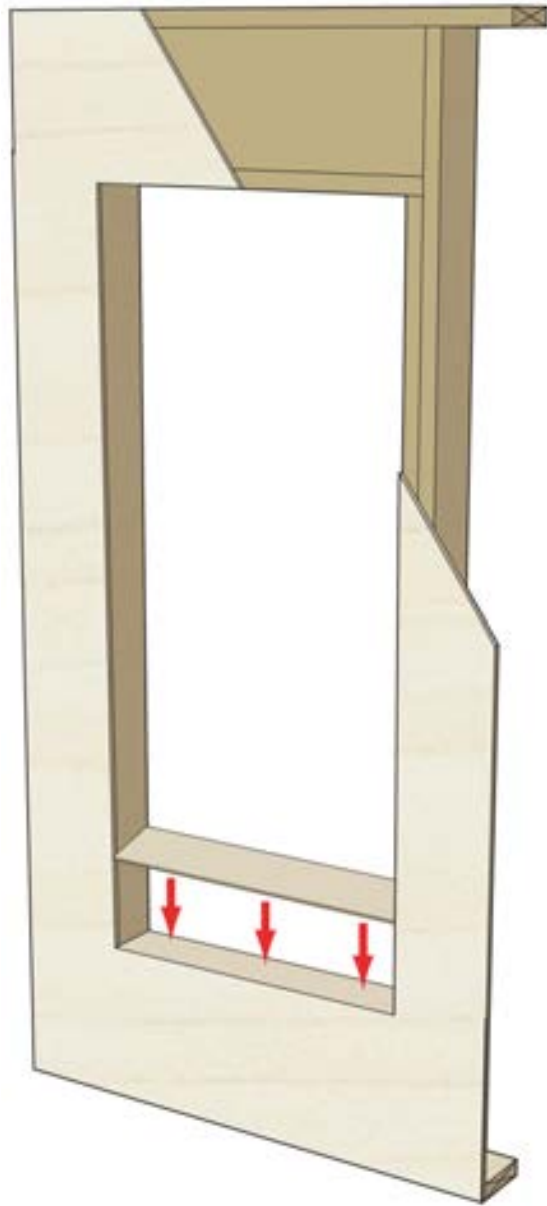

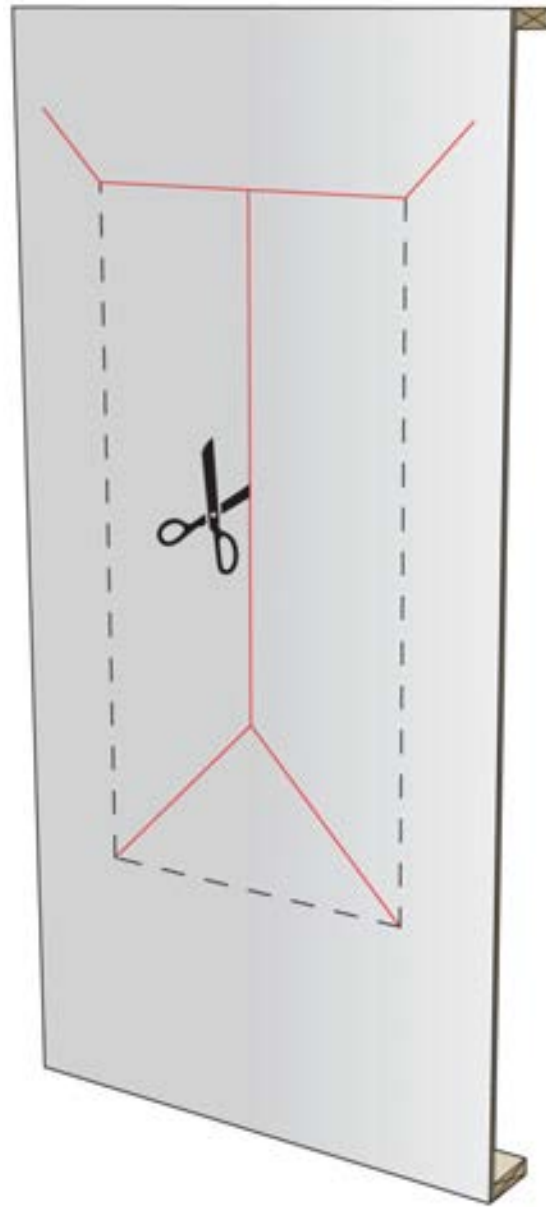



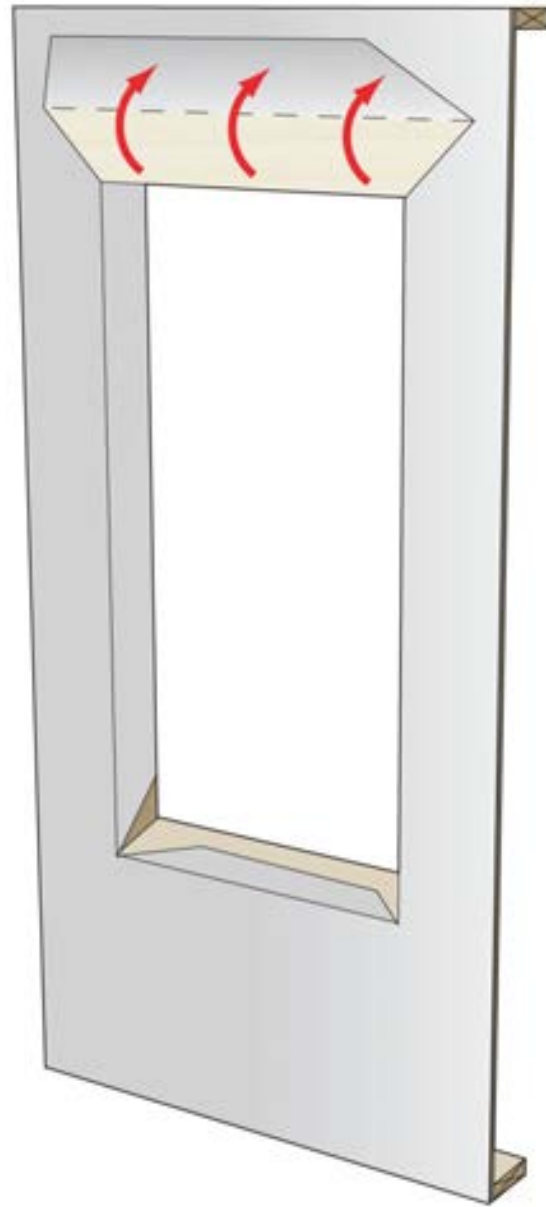

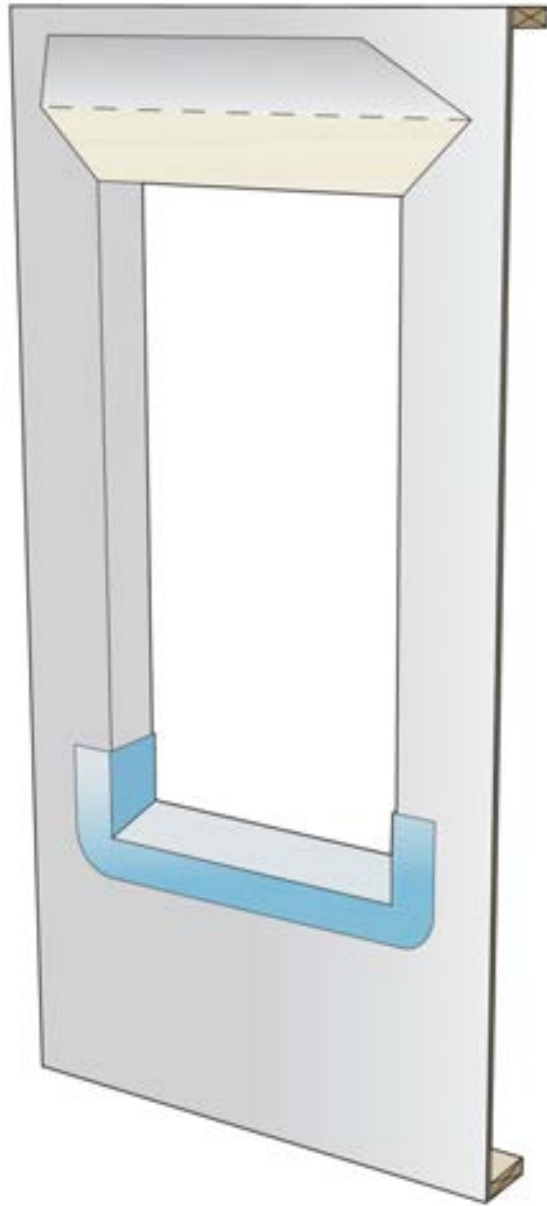

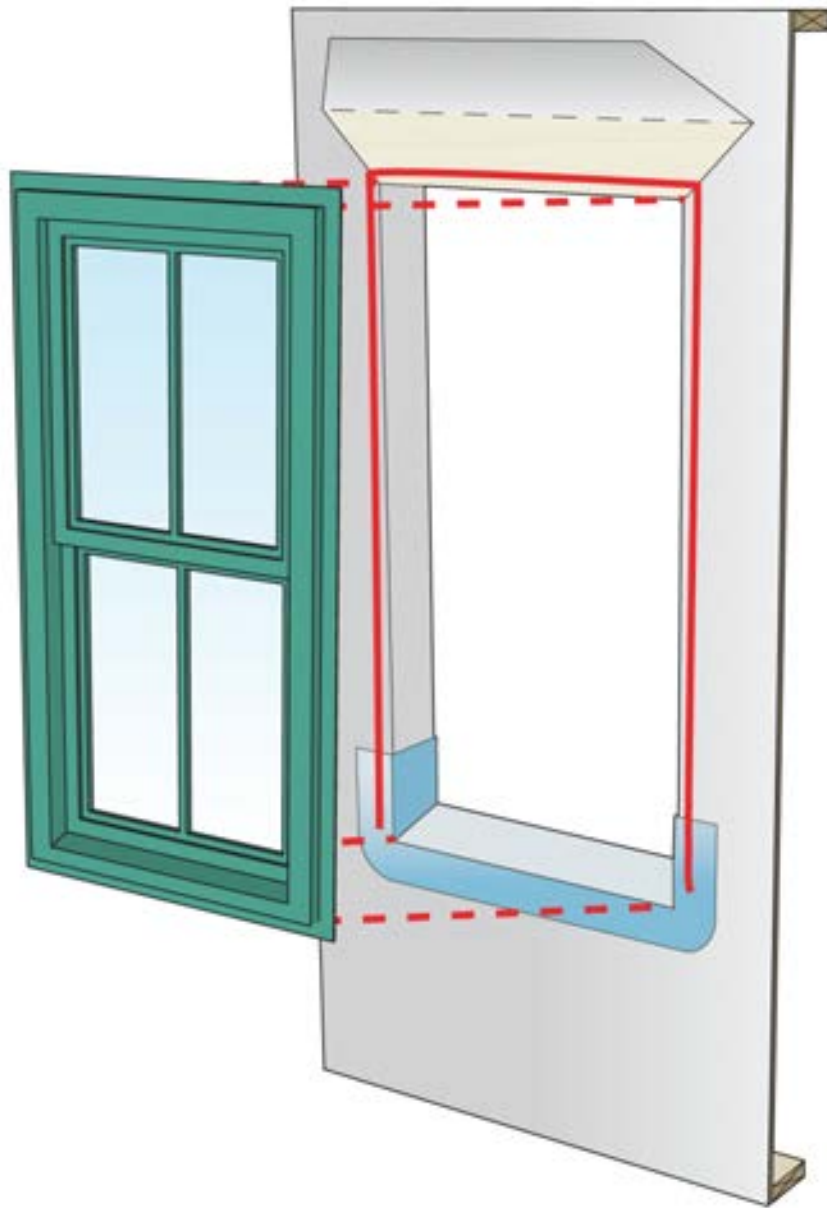

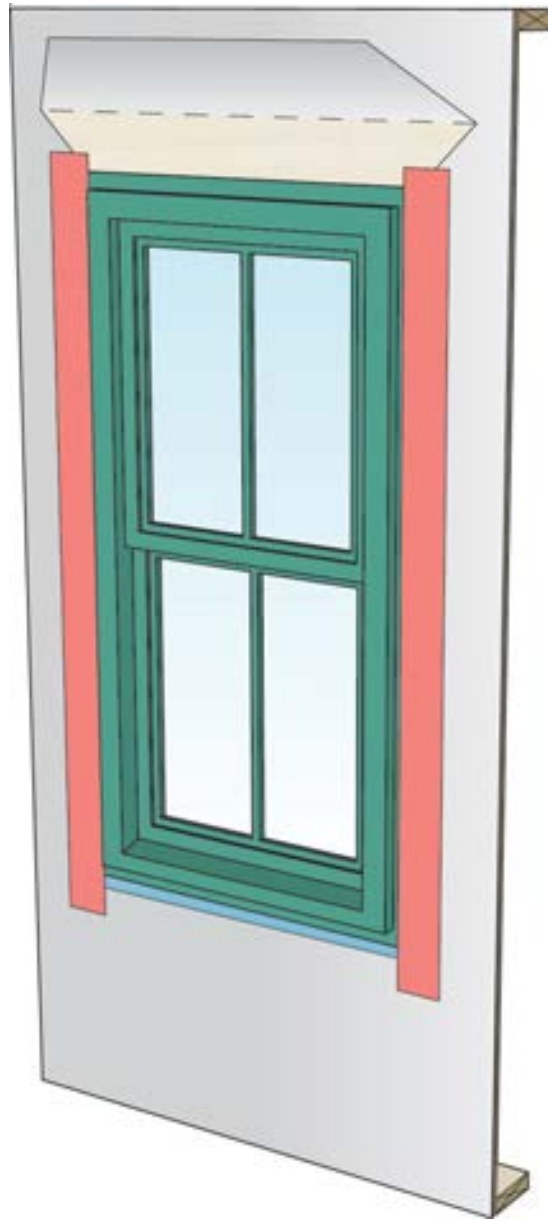

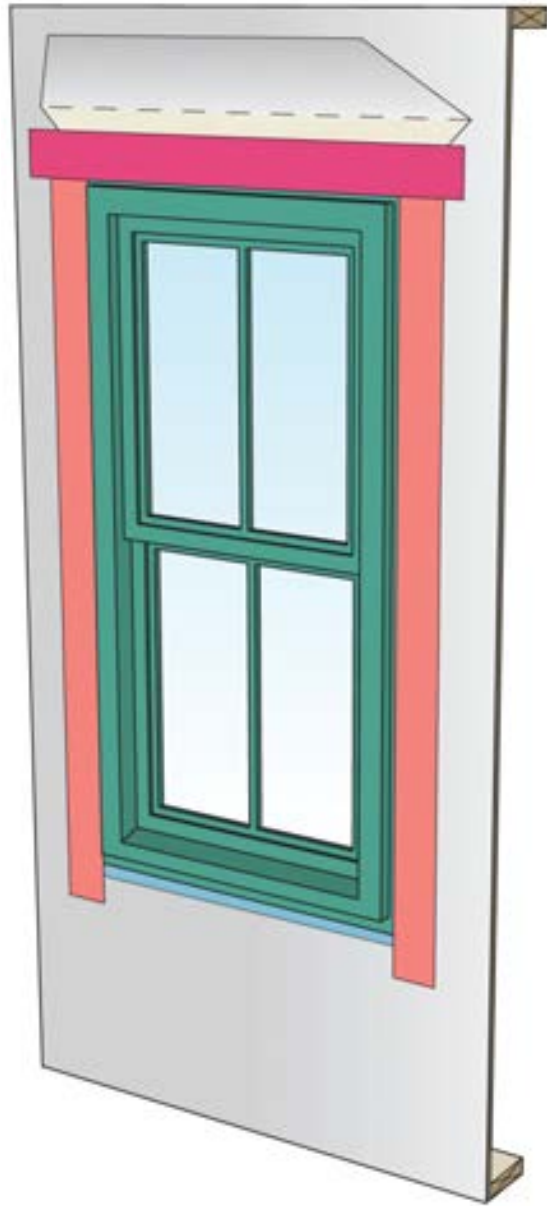



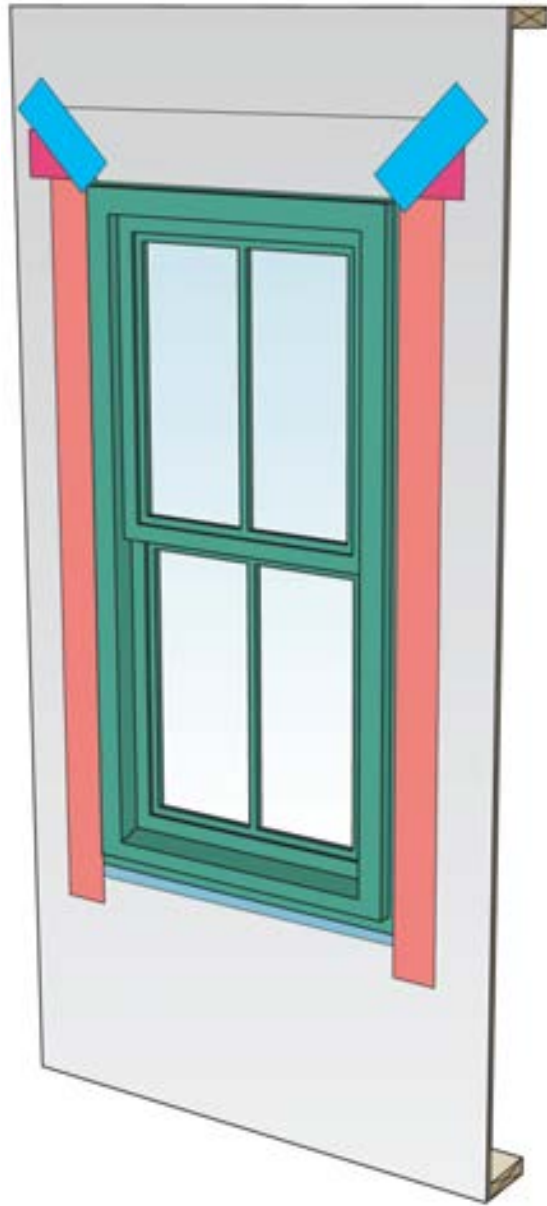

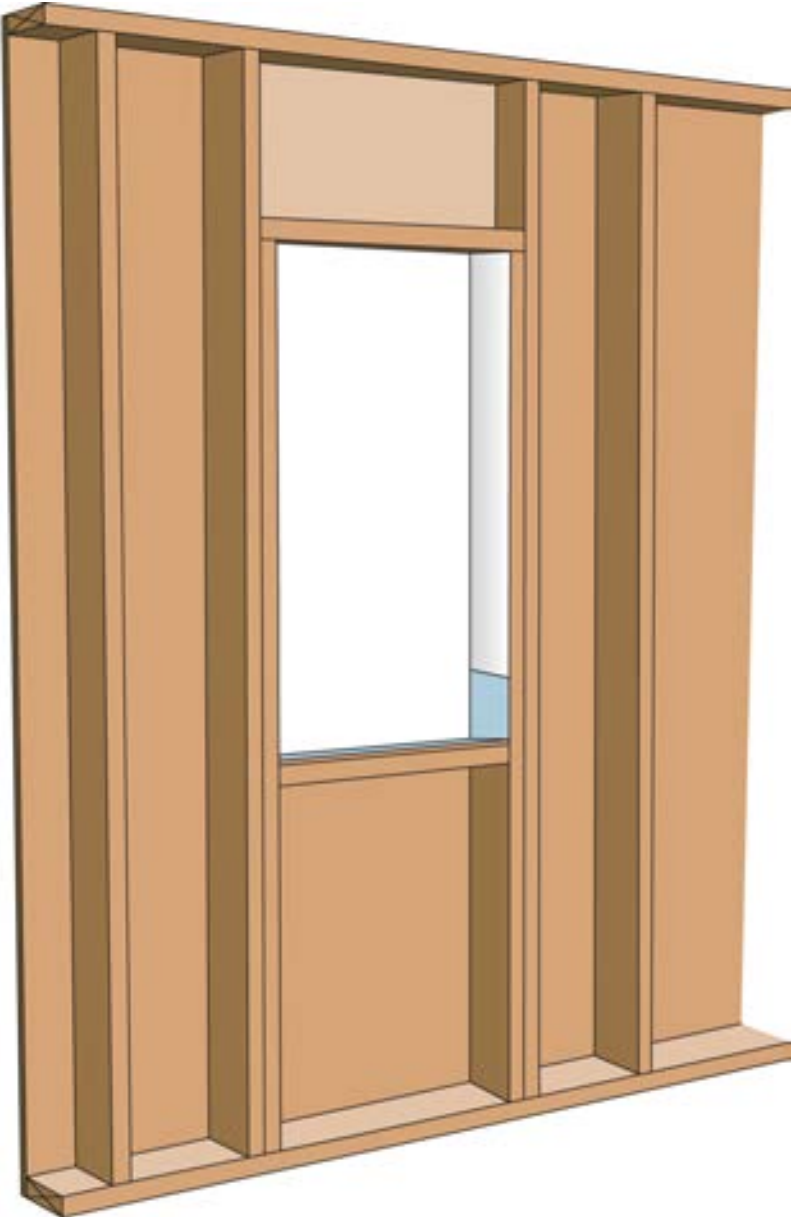



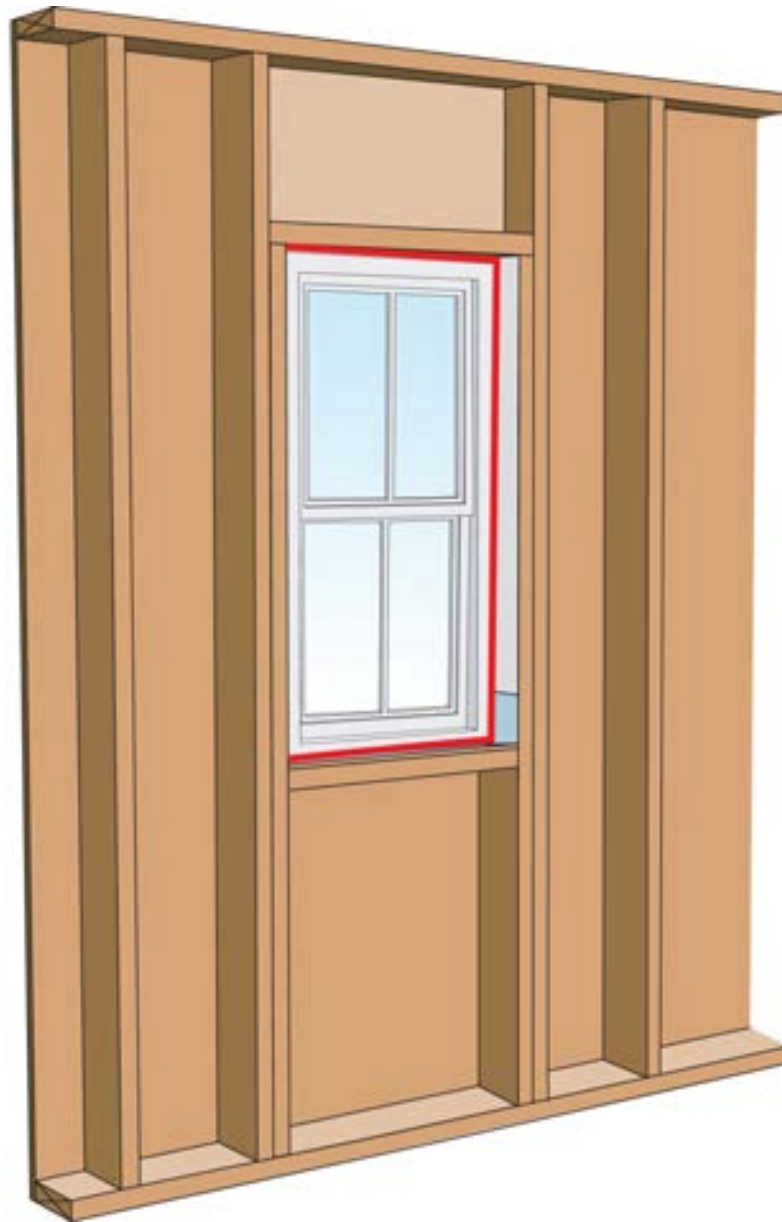





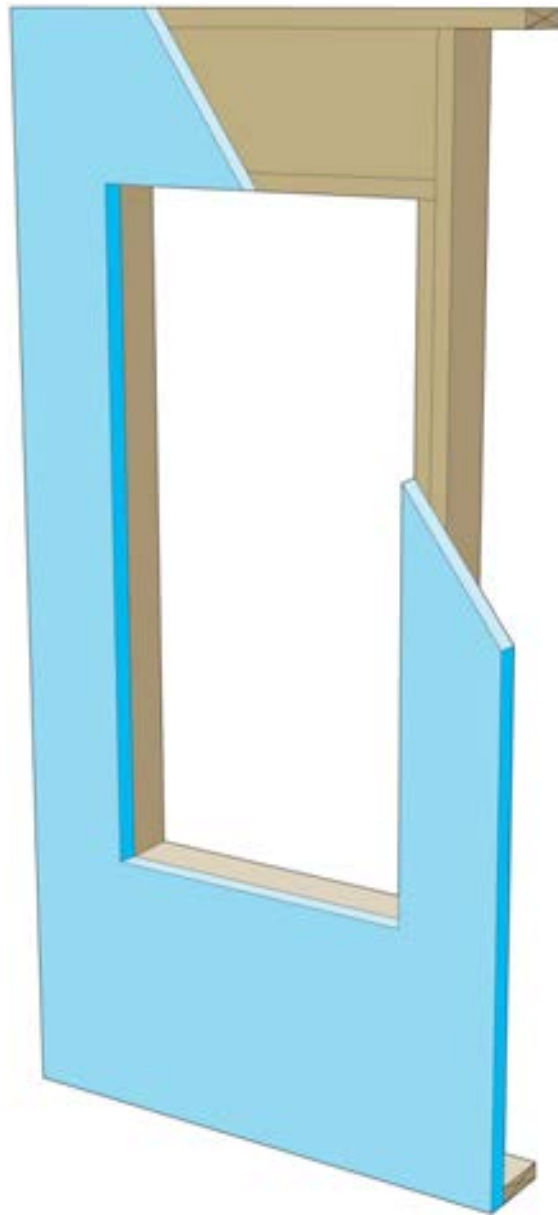

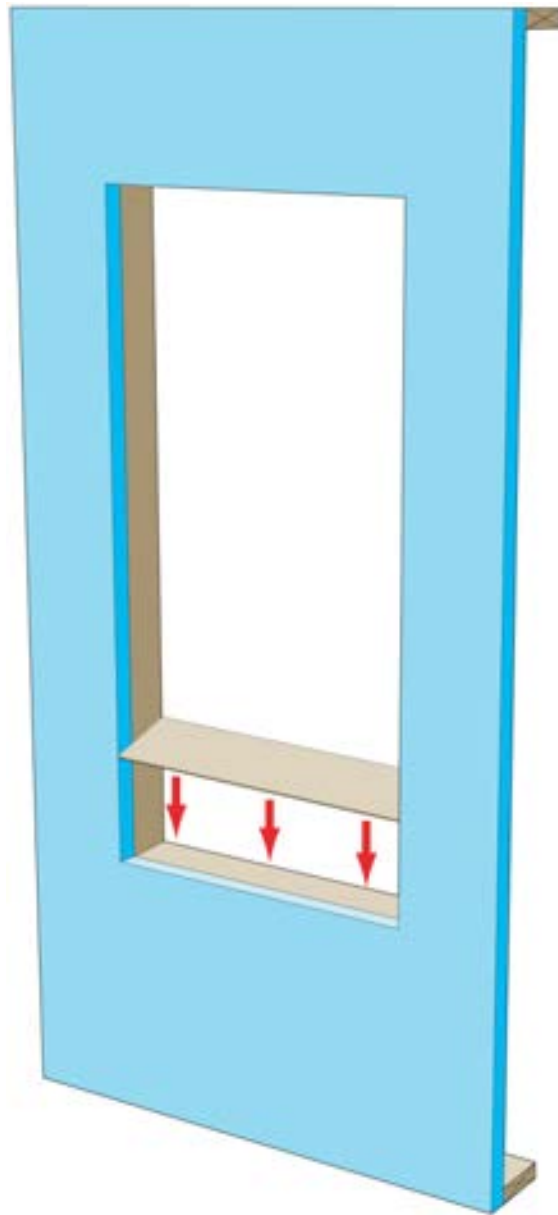

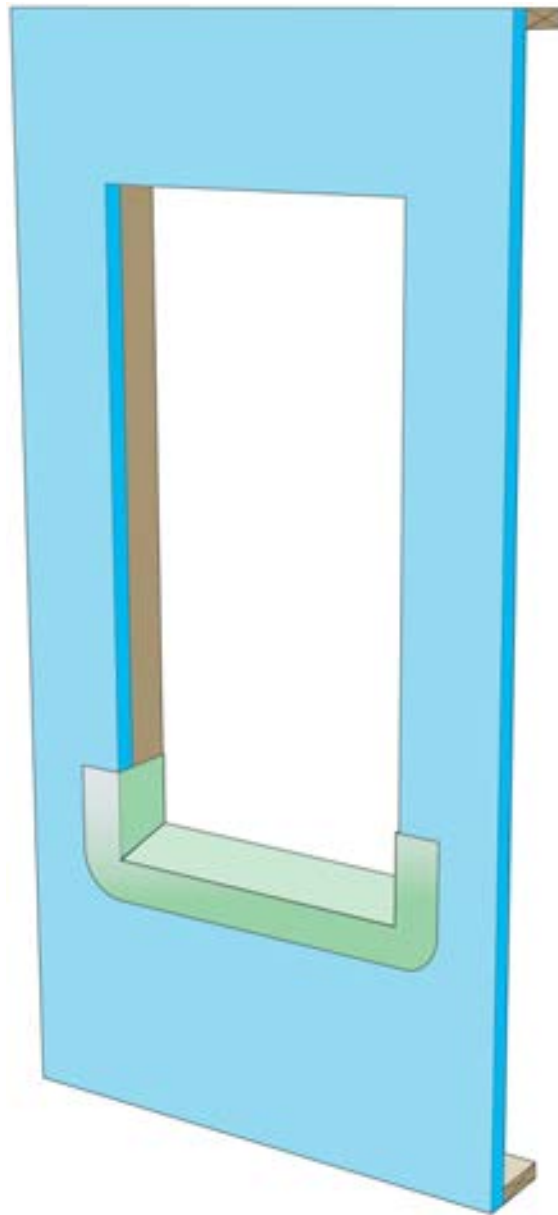

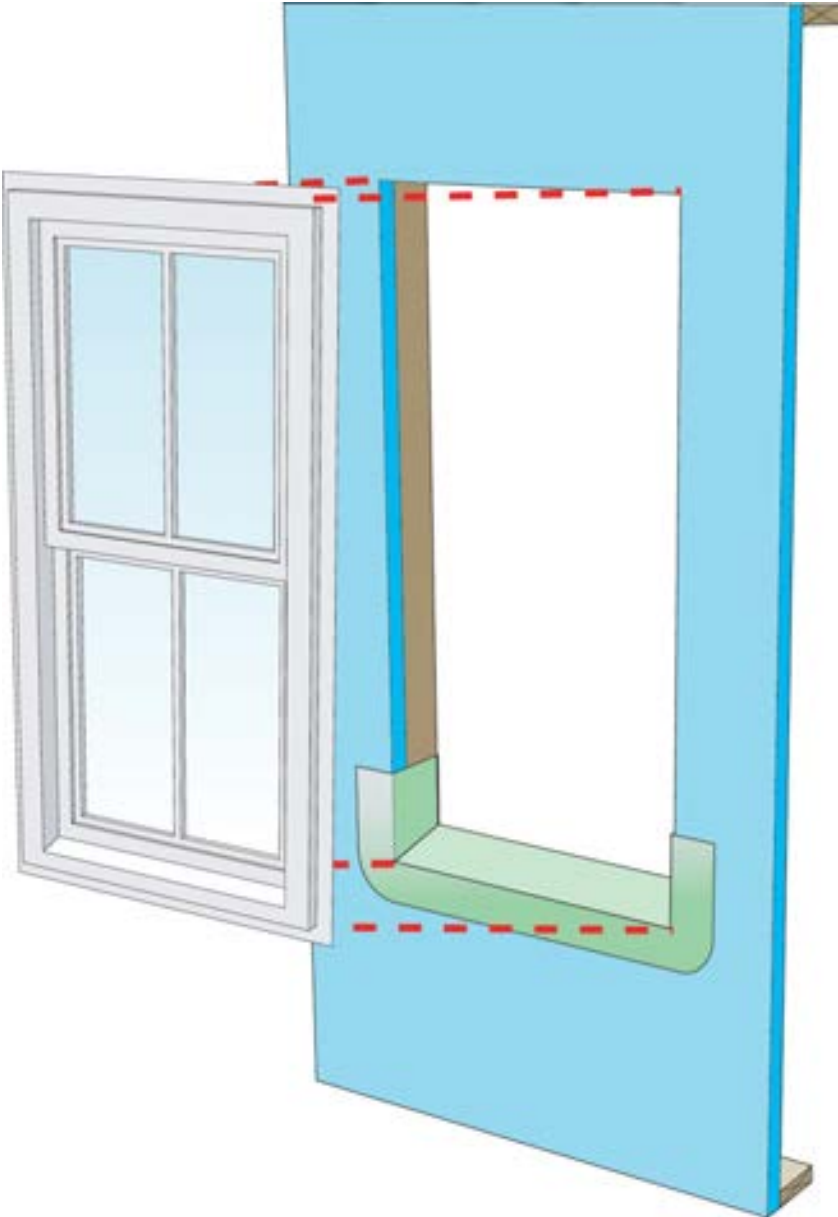









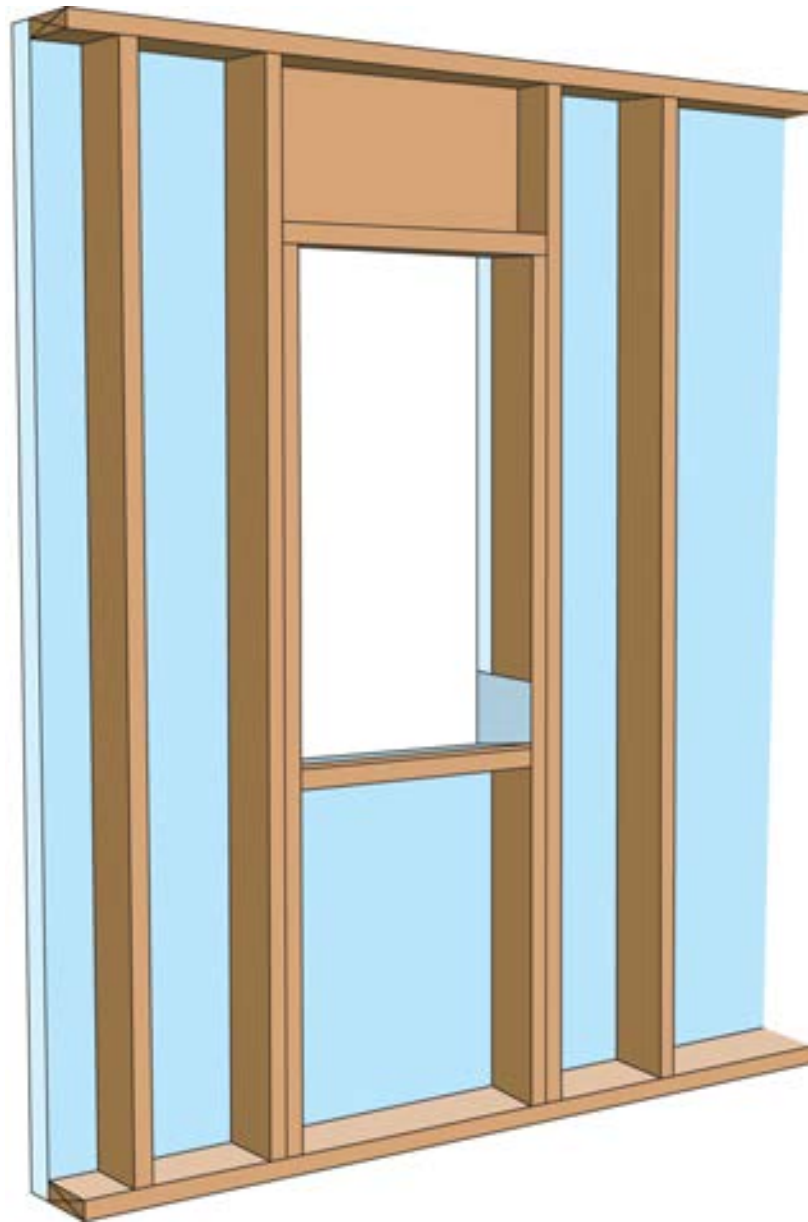



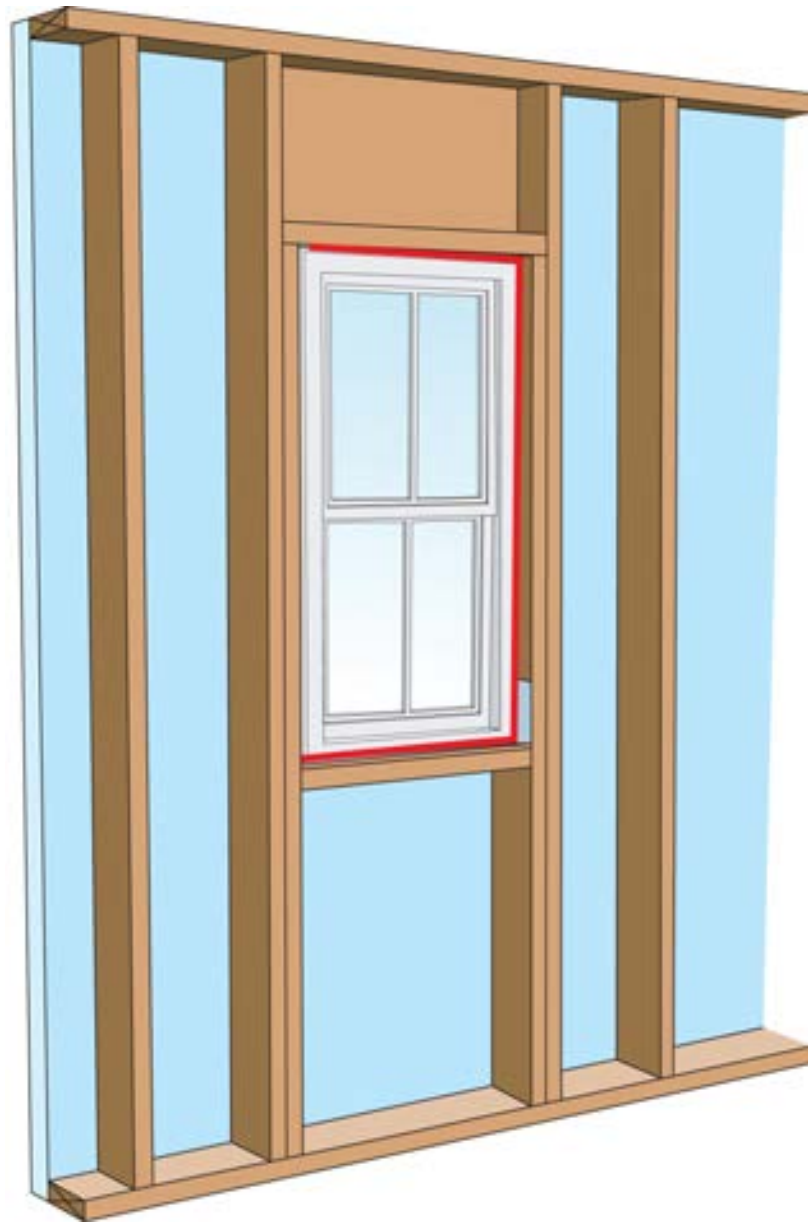







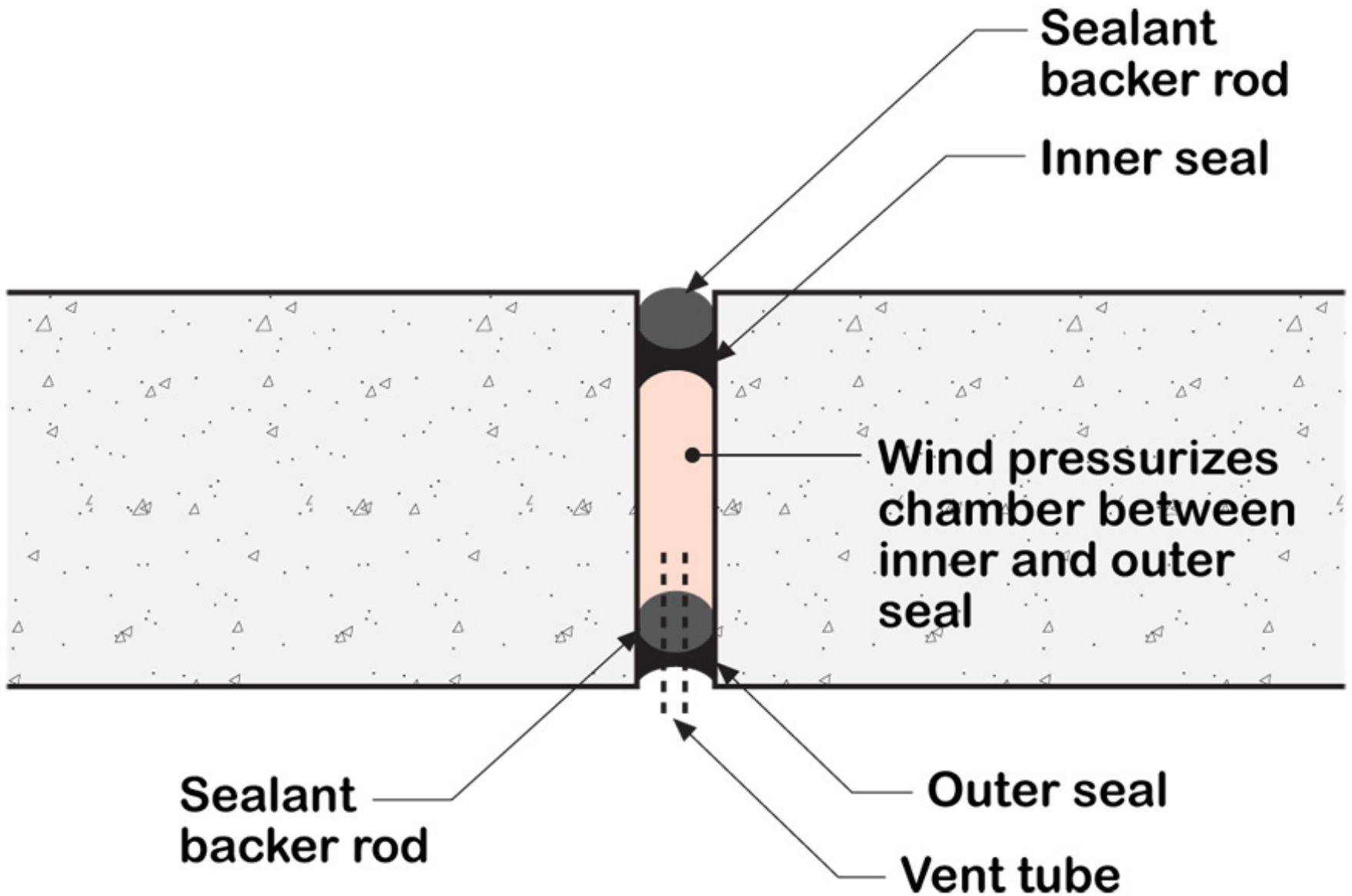

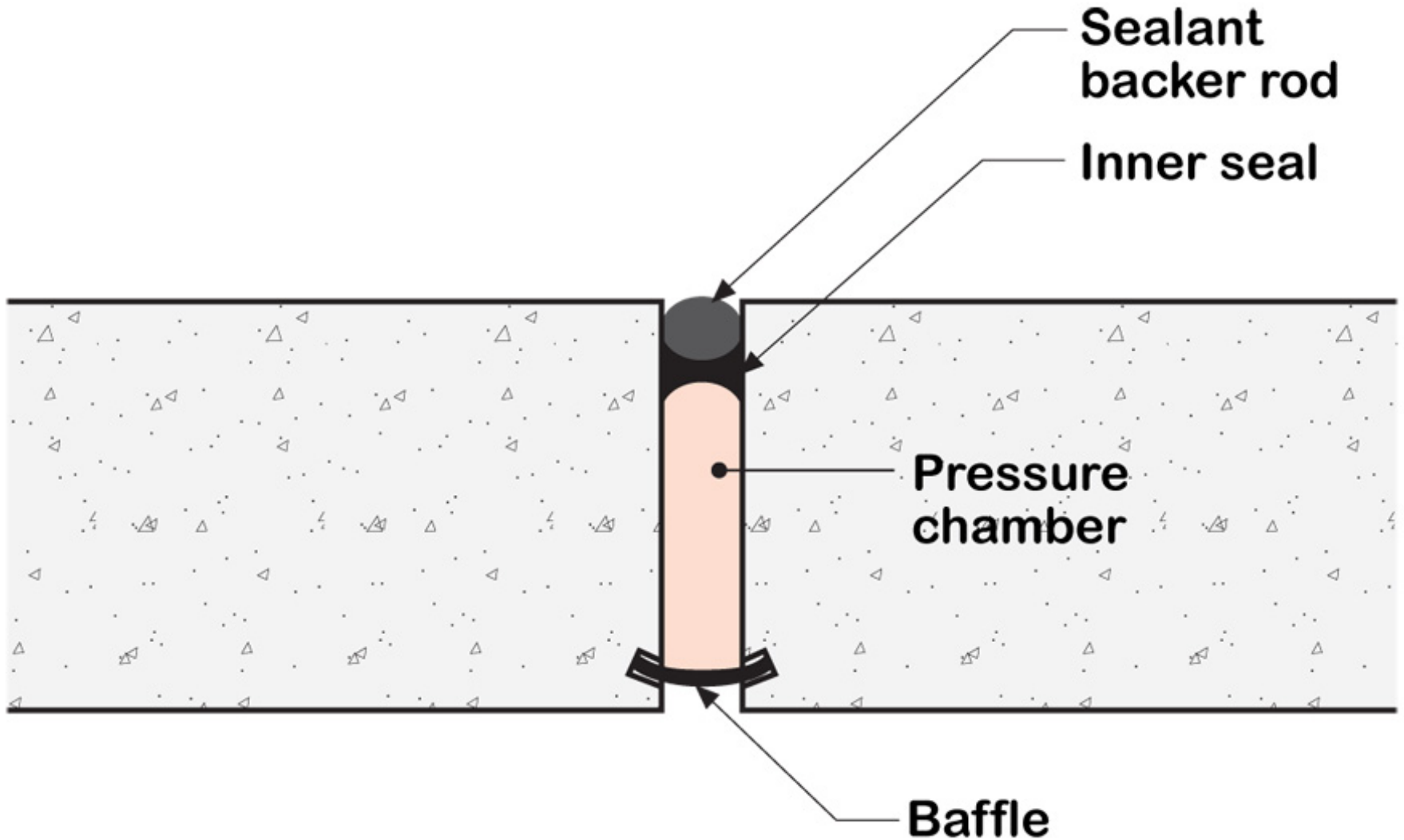

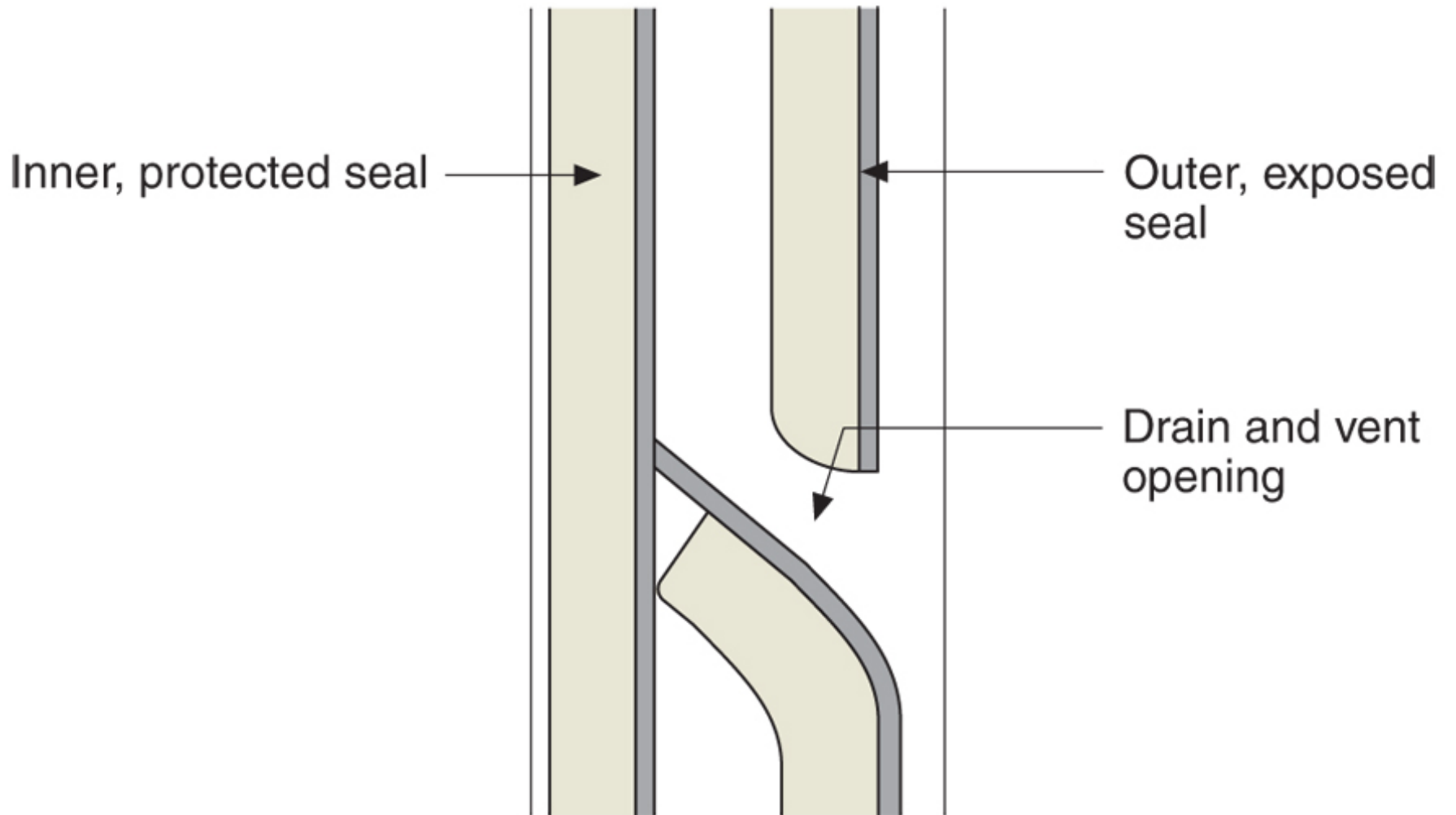





# Open Joints vs Closed Joints

# Open Joints vs Closed Joints

## Limits of Pressure Equalization

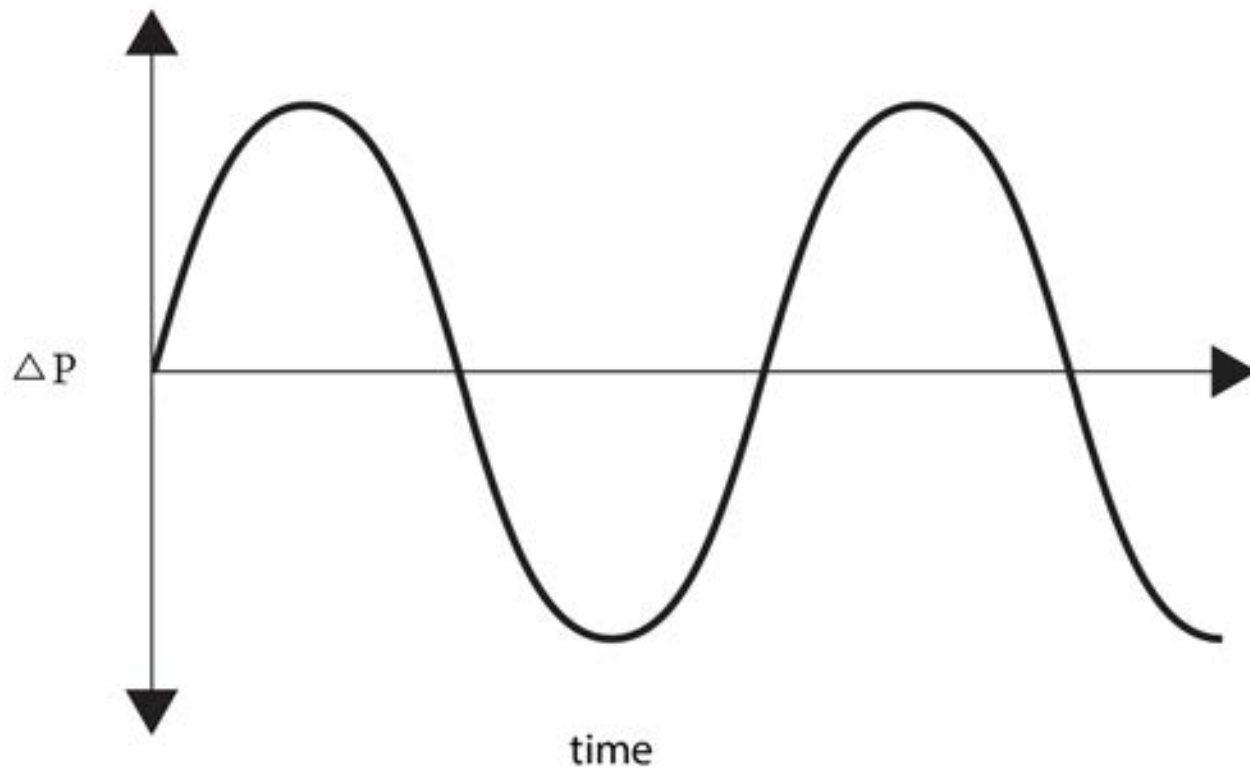

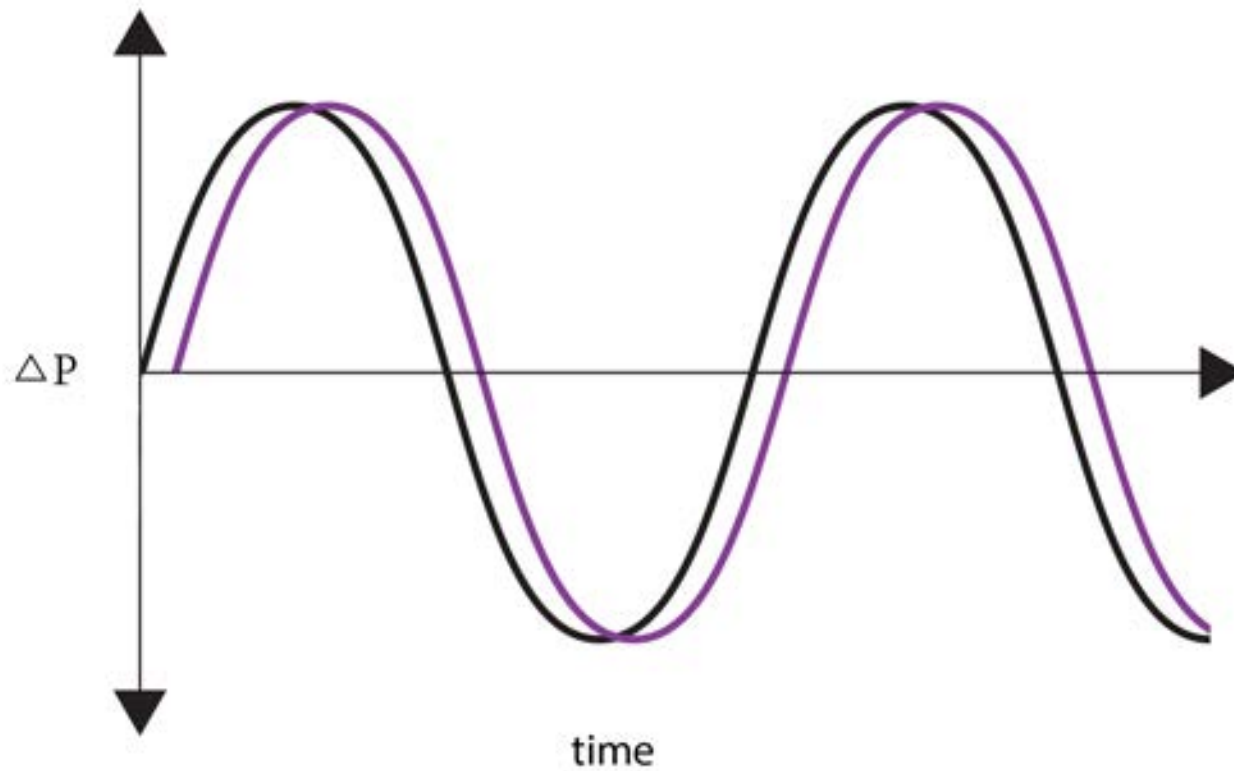



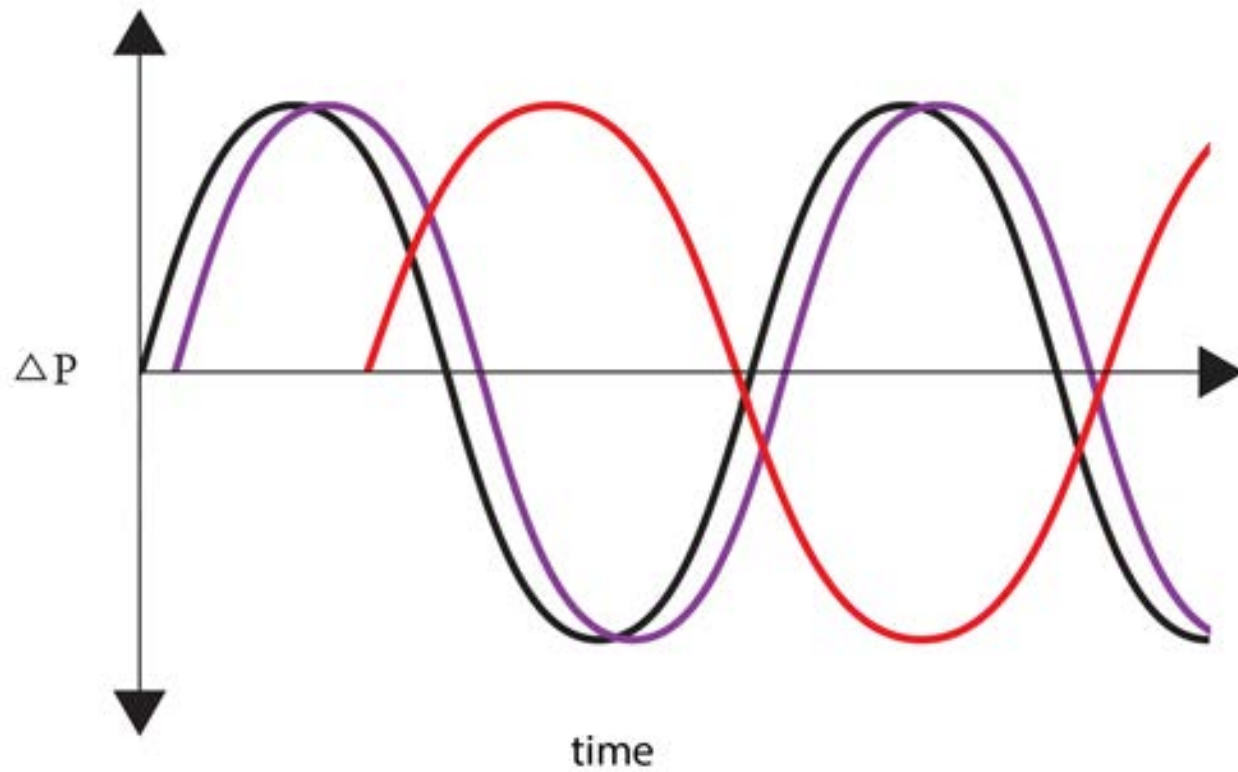













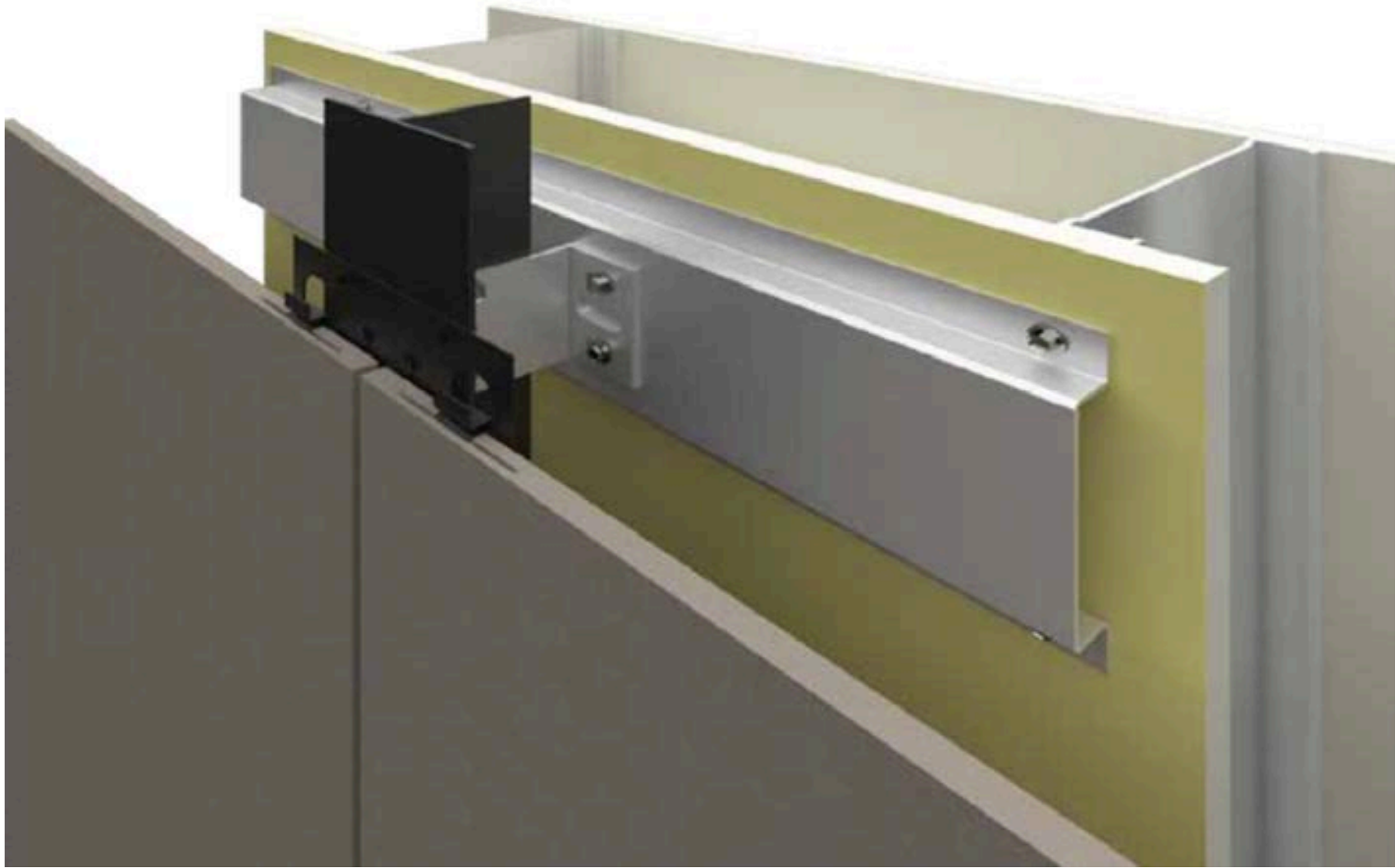

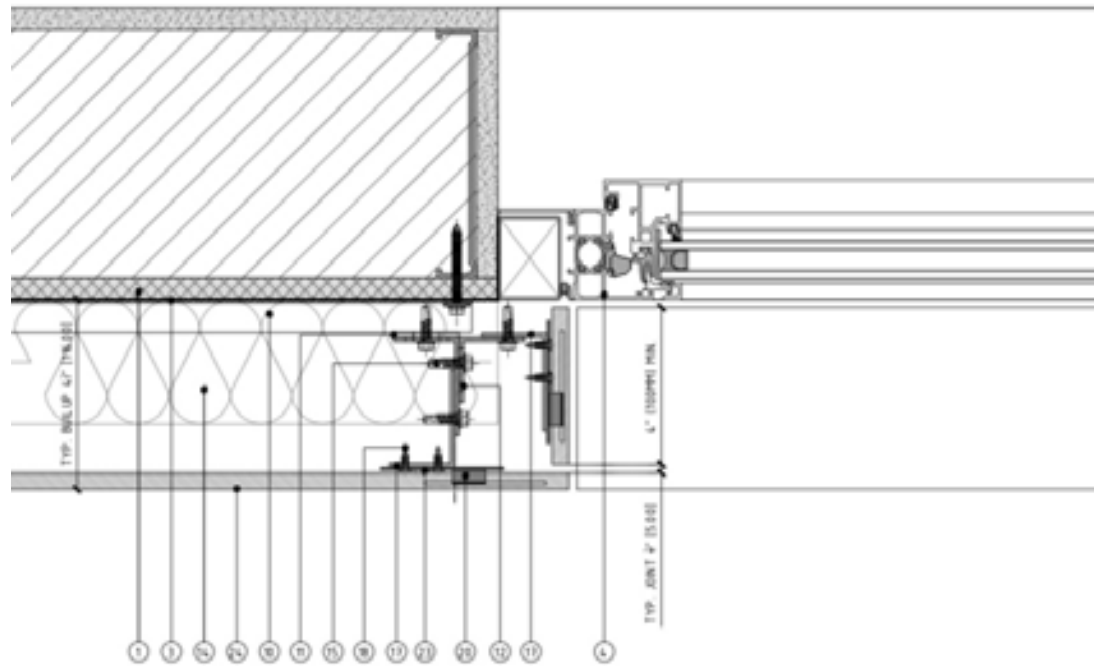























Life is Tough Enough As it Is...

Life is Tough Enough As it Is...  
It's Harder When You Are Stupid

Don't Do Stupid Things

















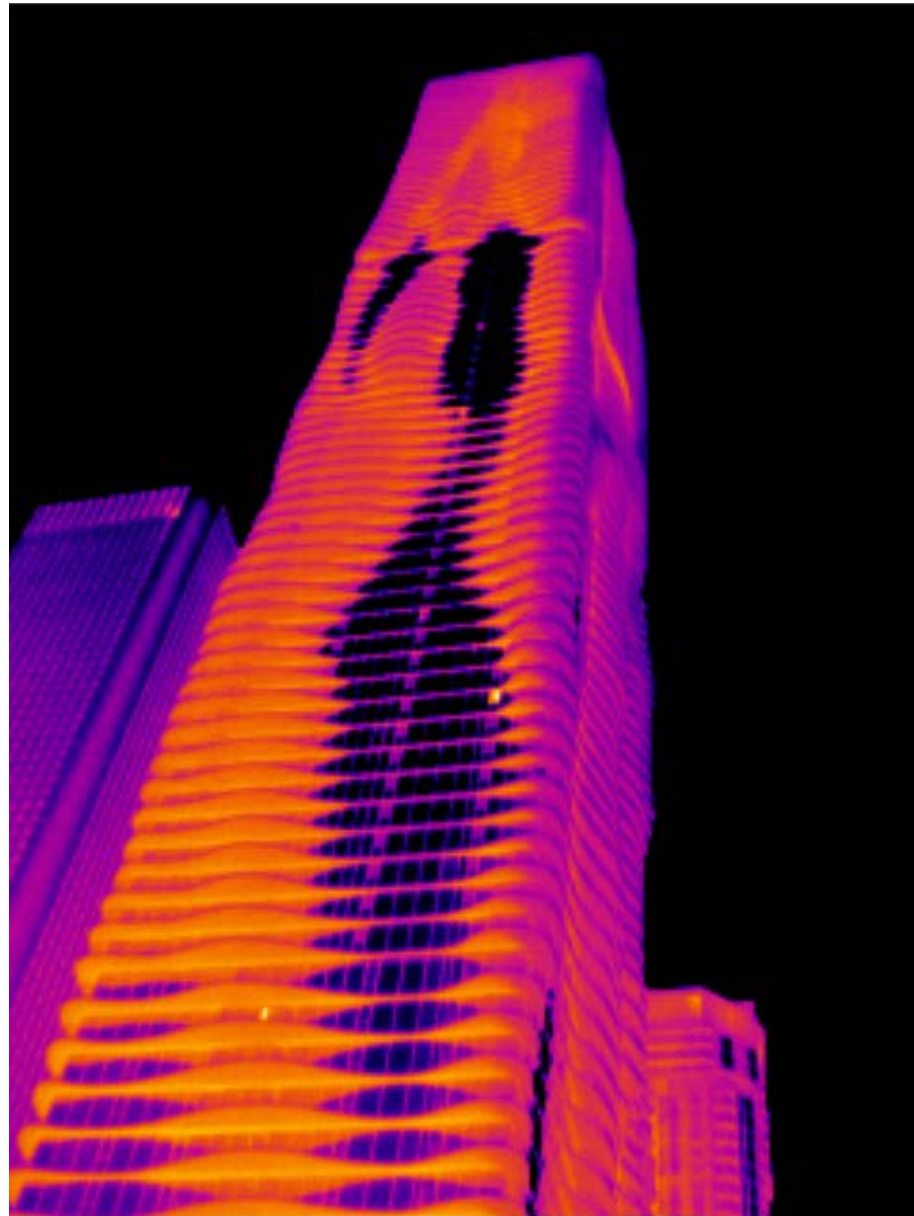



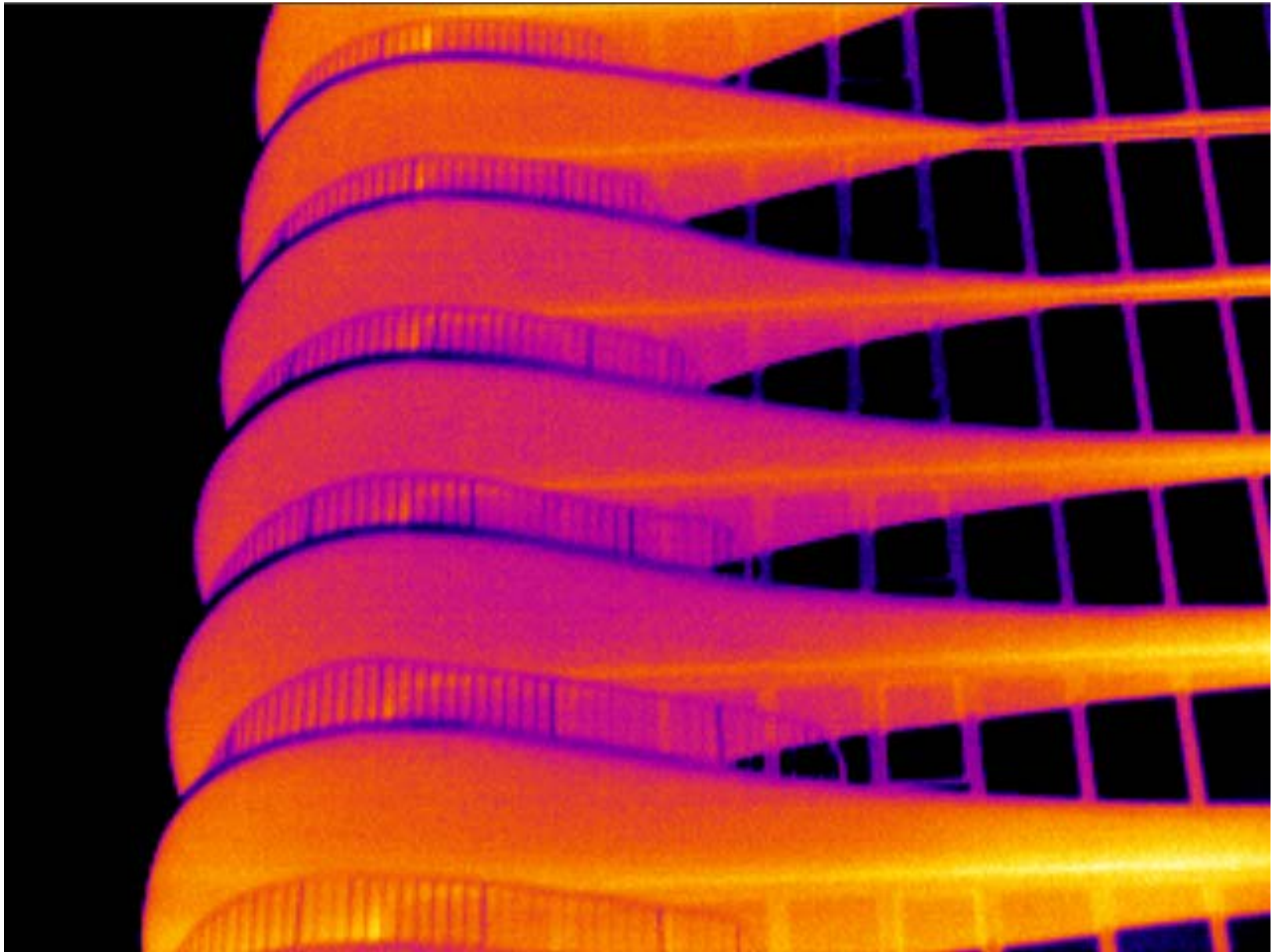

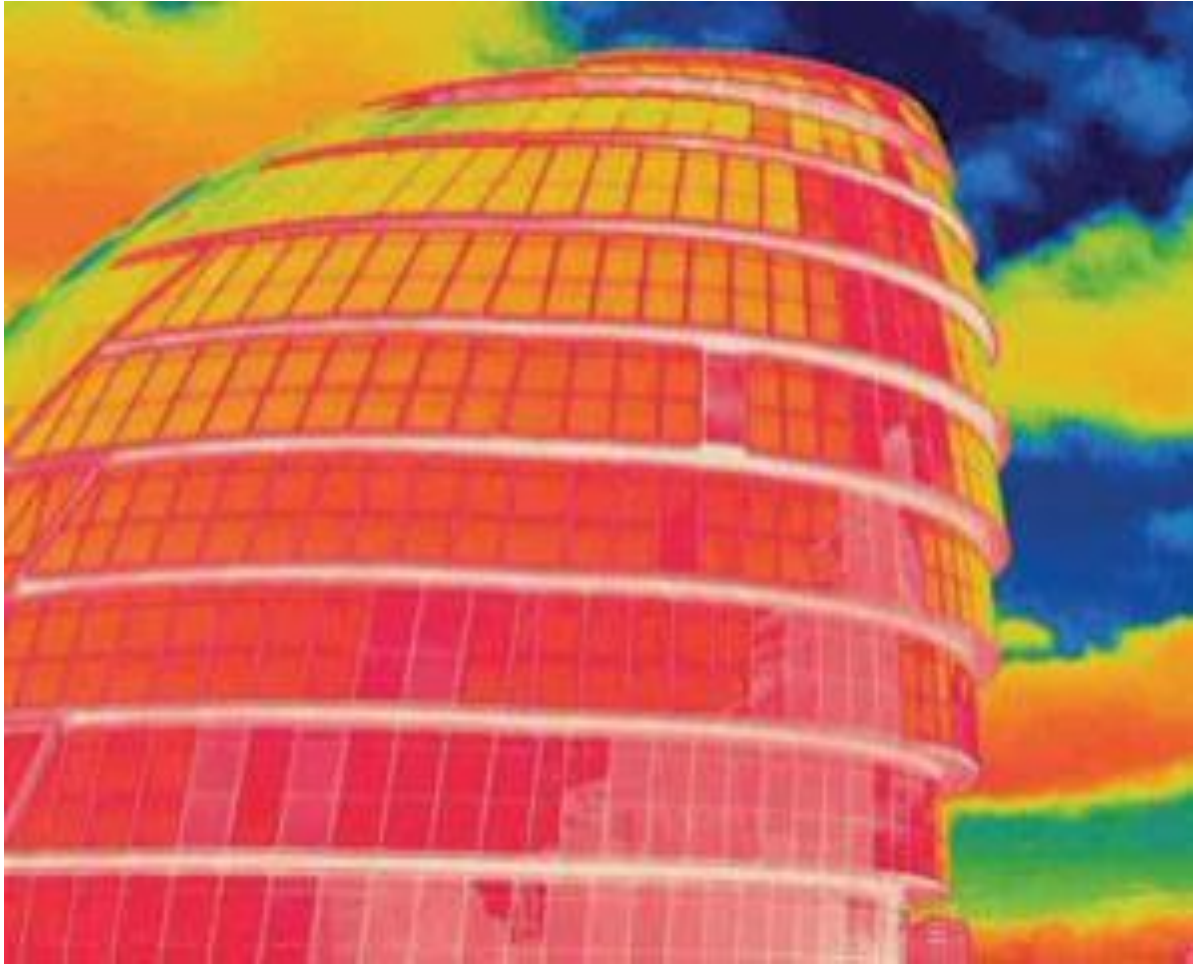







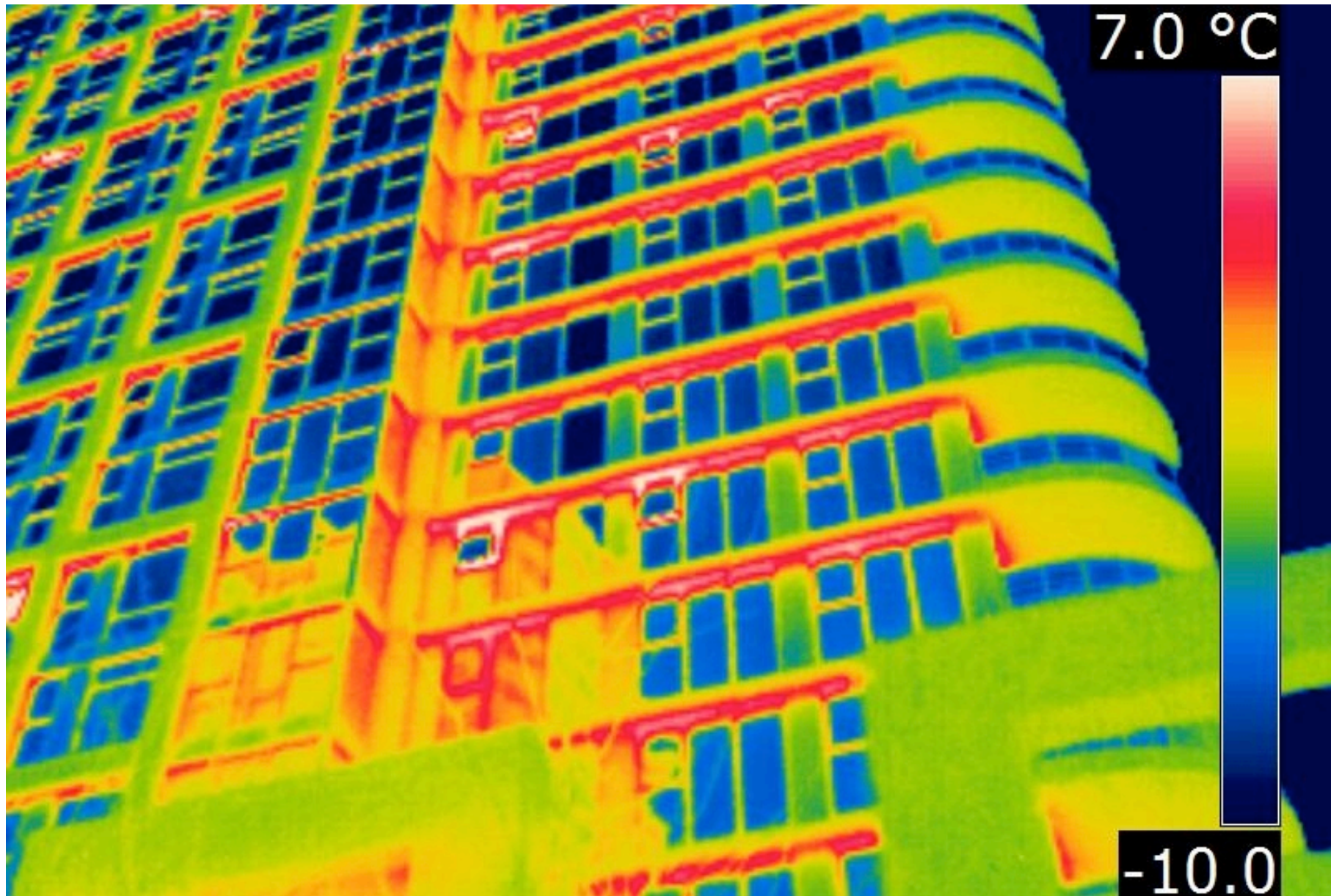



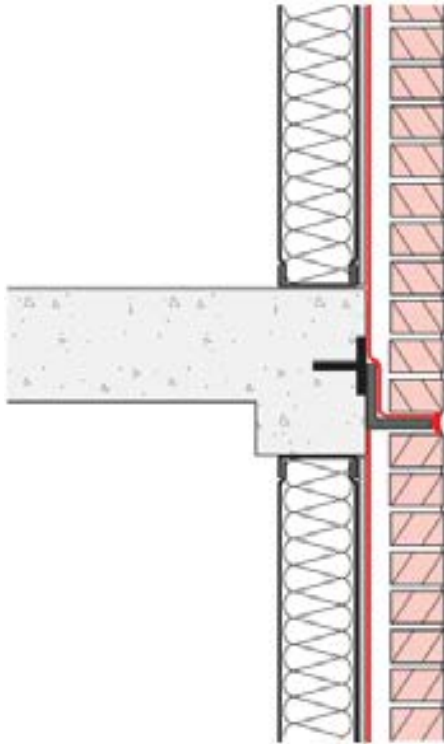

**“The Ugly”**

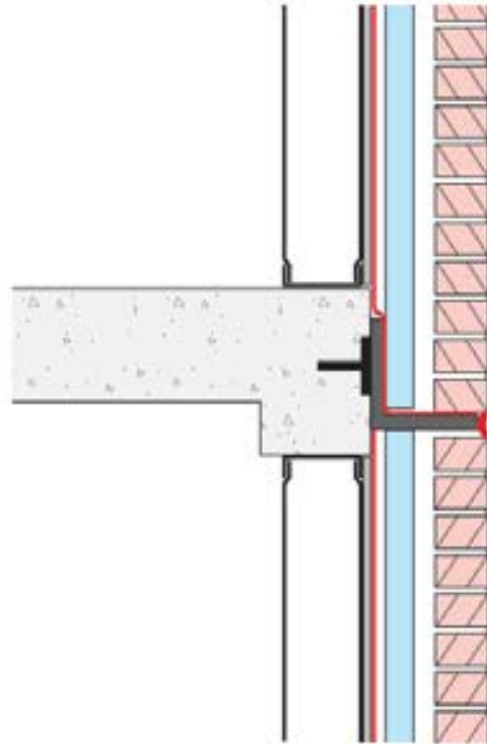

**“The Bad”**

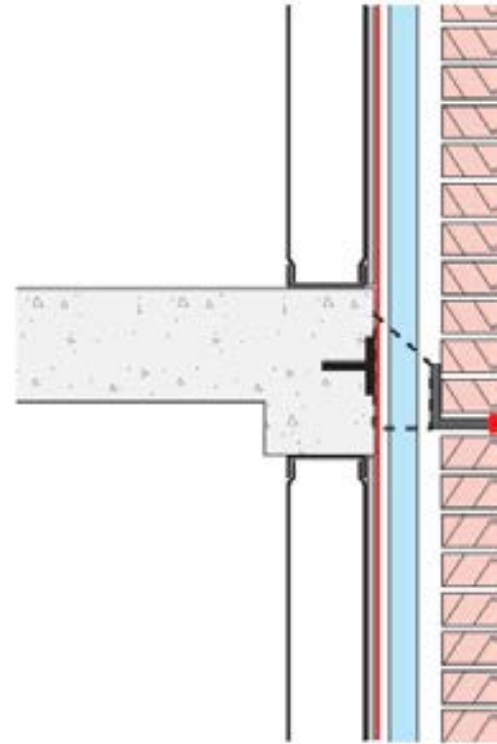

**“The Good”**











WEDGE SHIMS INSERTED BEHIND/FRONT OF ANGLE TO ENSURE DIRECT BEARING ON BRACKET AND PROVIDE LEVEL (IF NECESSARY)

