

Joseph Lstiburek, Ph.D., P.Eng, ASHRAE Fellow

Building Science

Ventilation

www.buildingscience.com

Lapse Rate

Building Science Corporation

Joseph Lstiburek 2

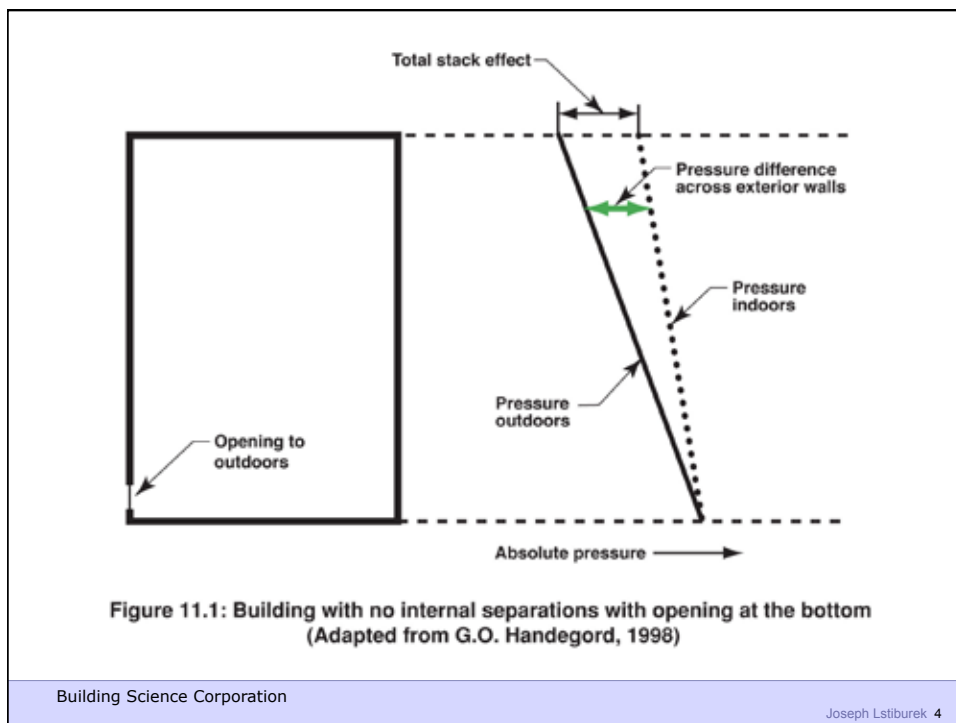
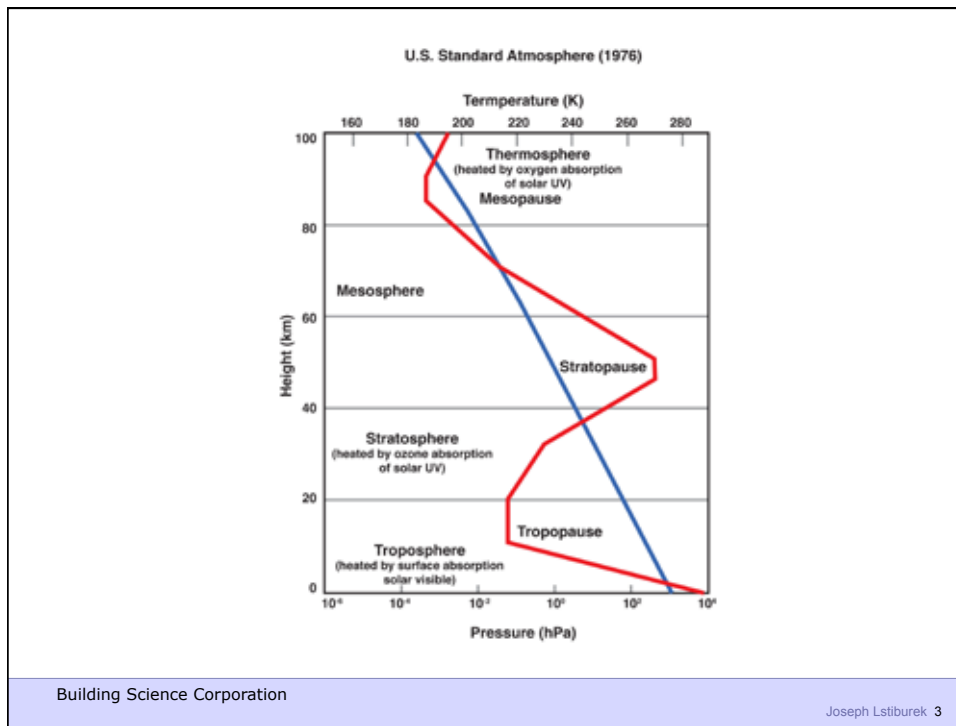

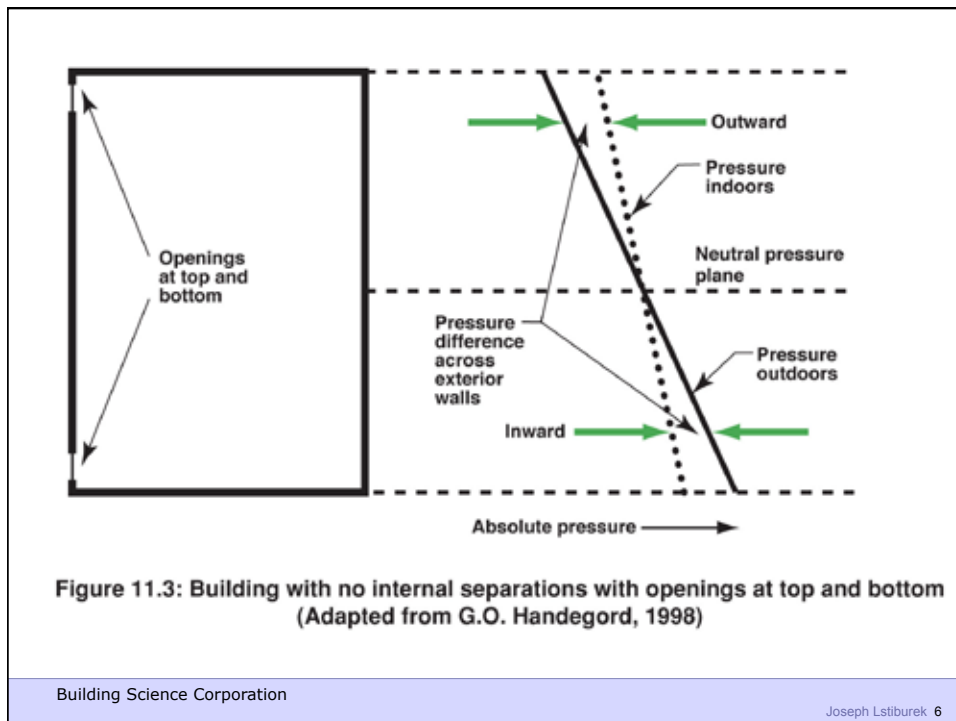
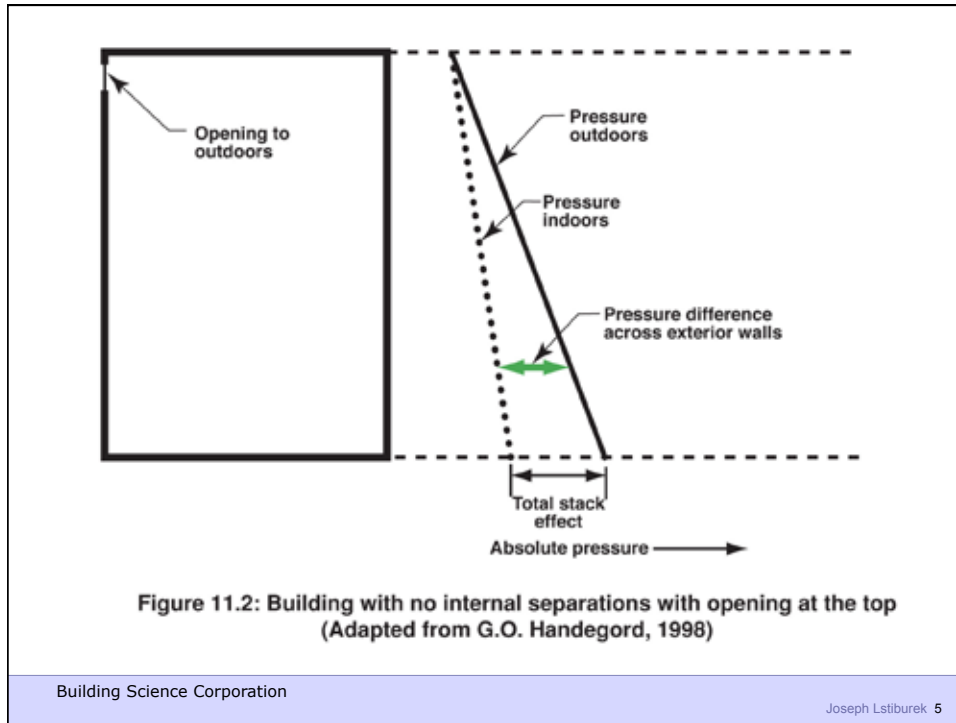

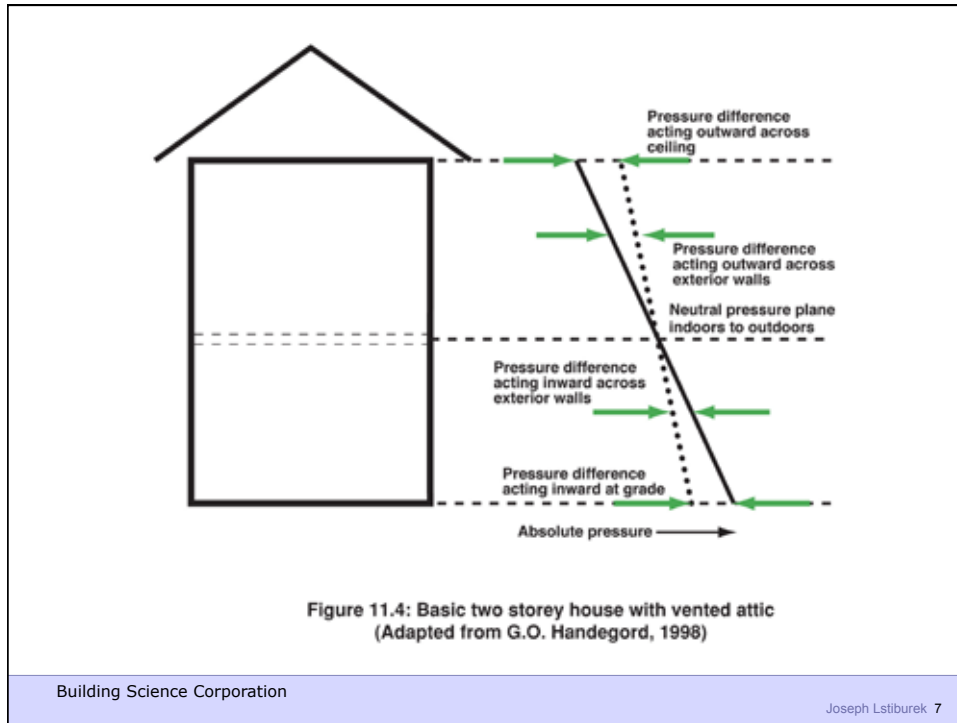

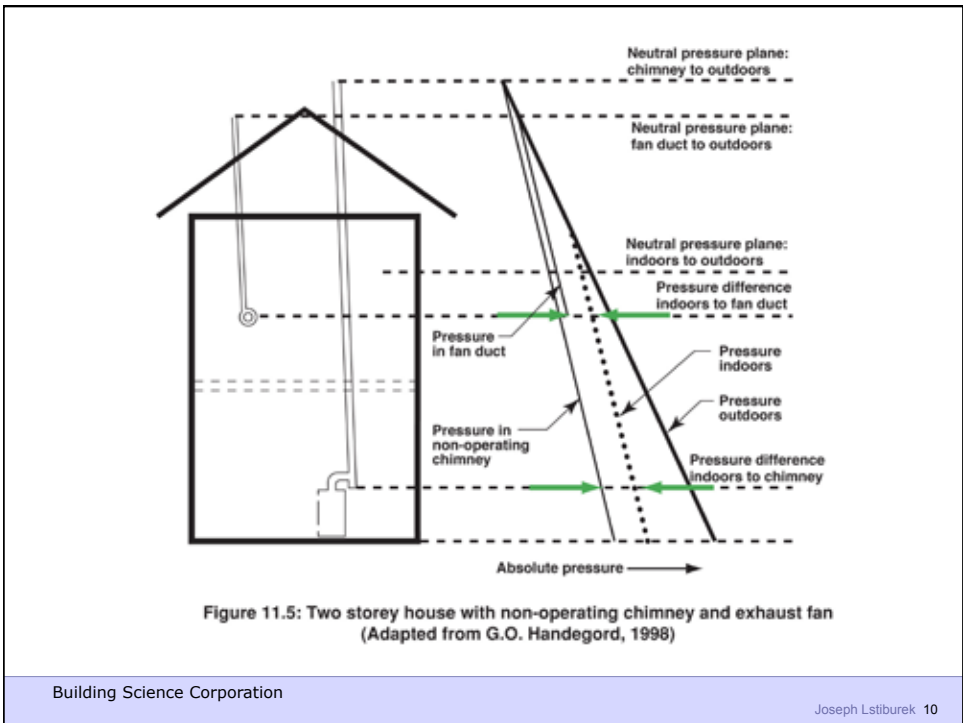

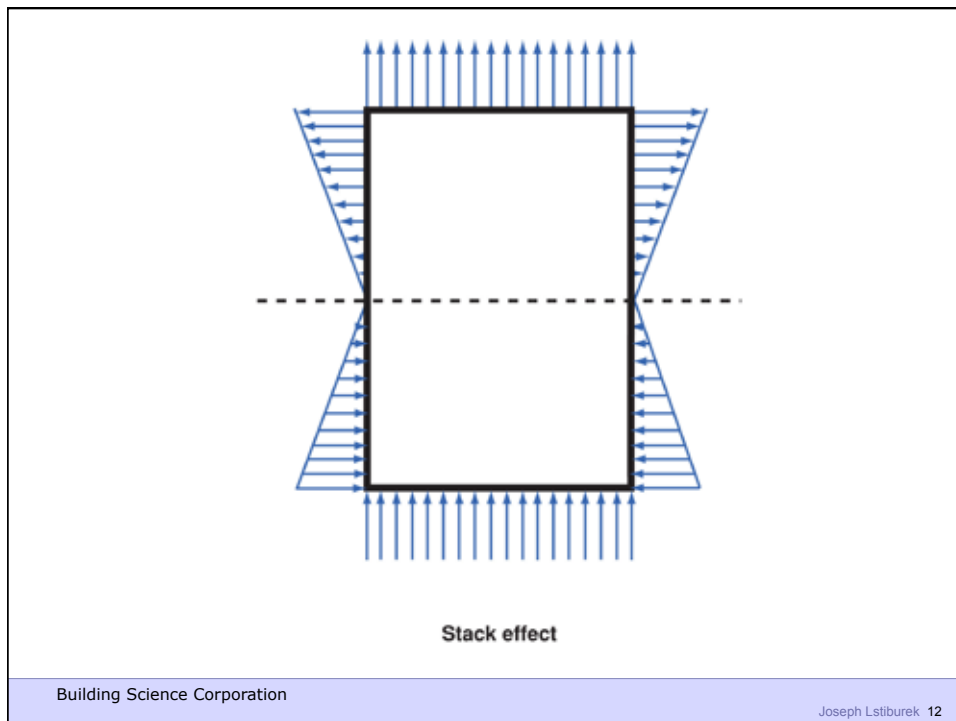
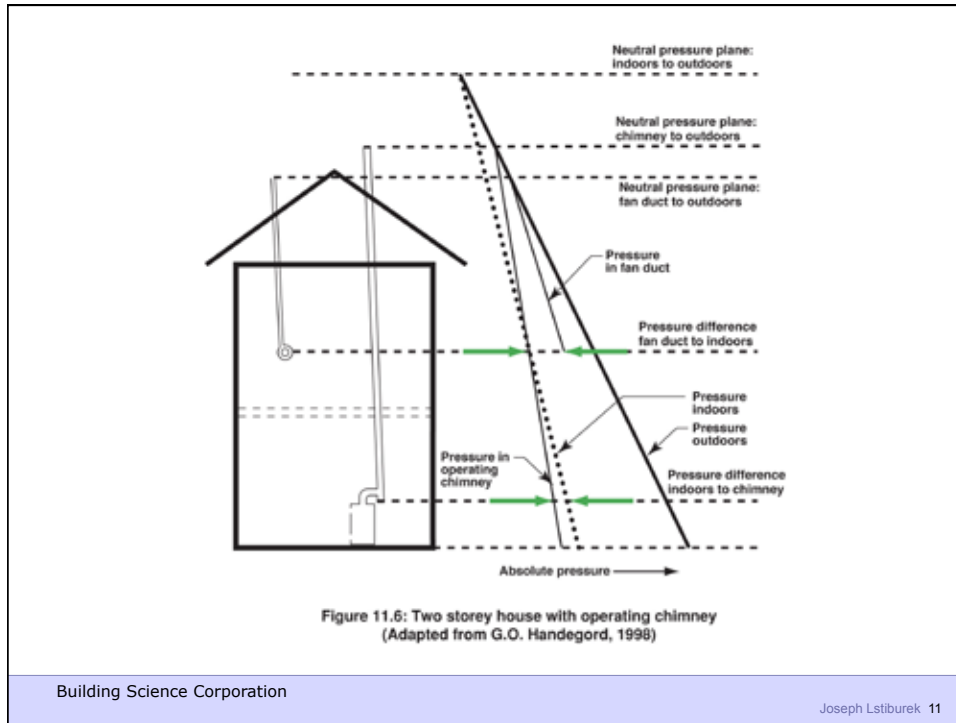

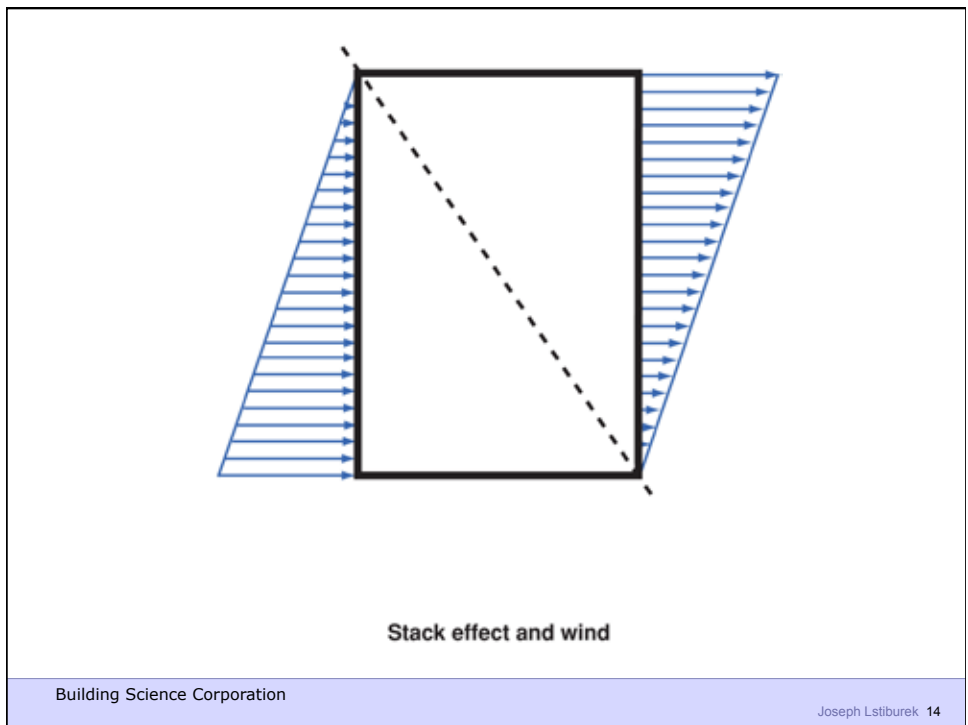
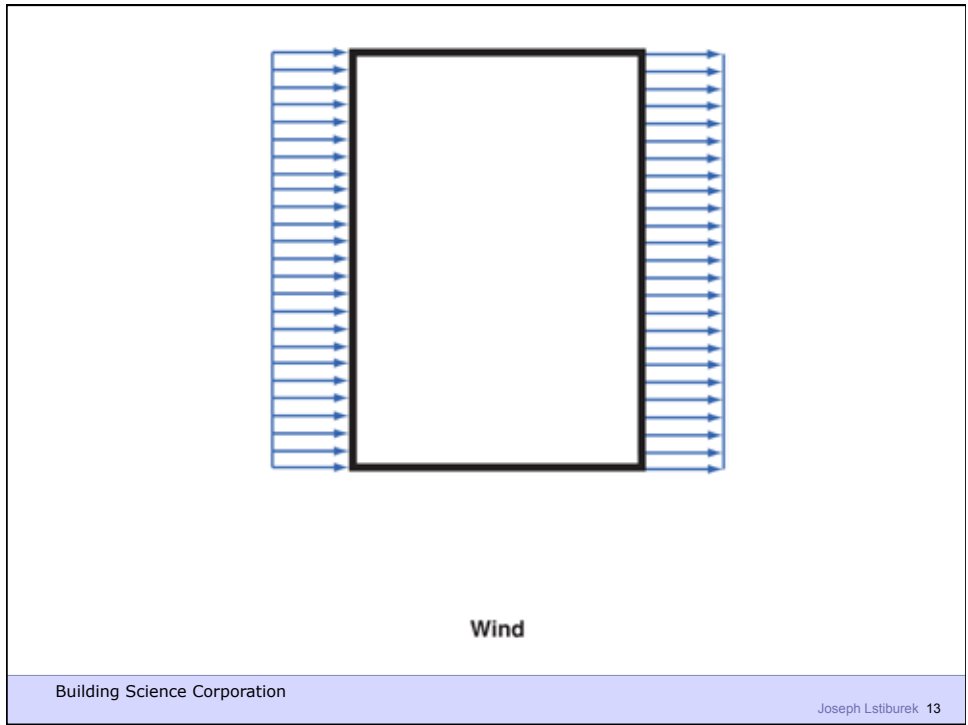

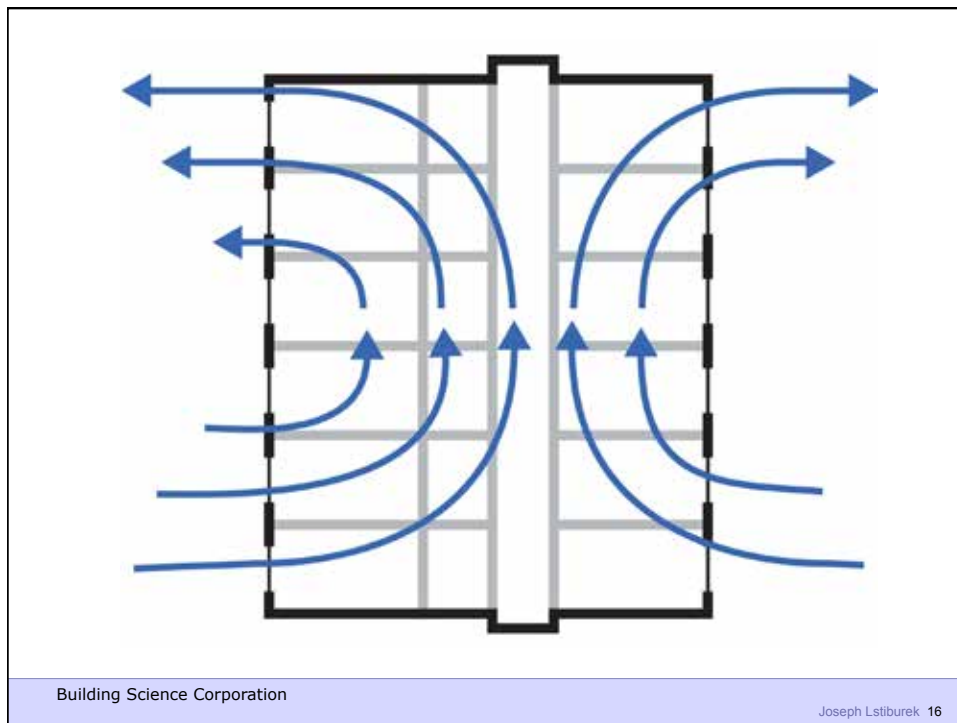
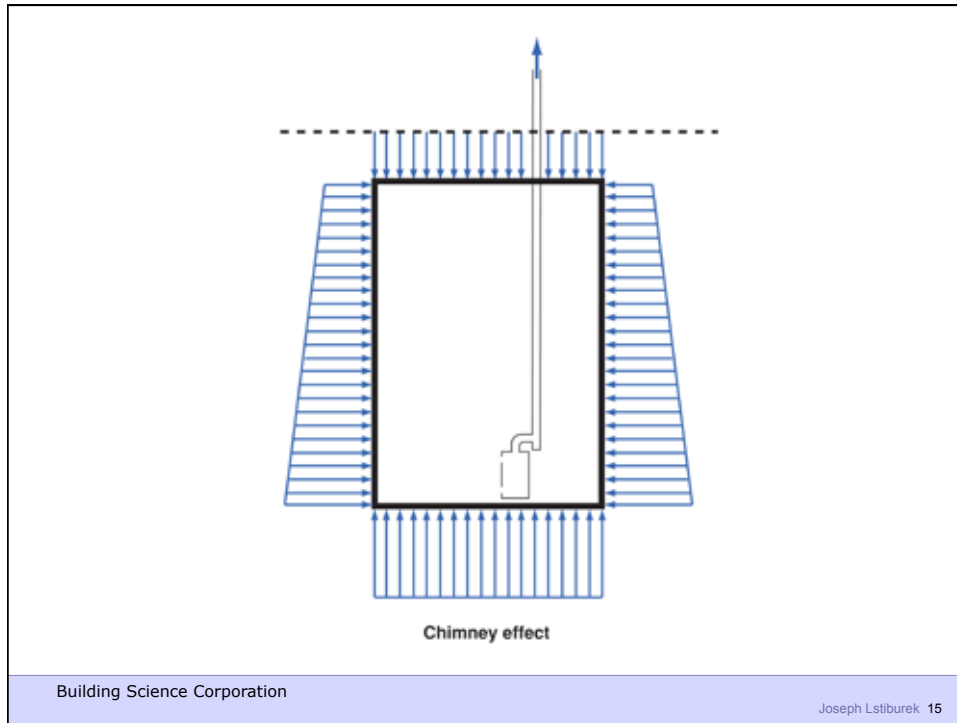

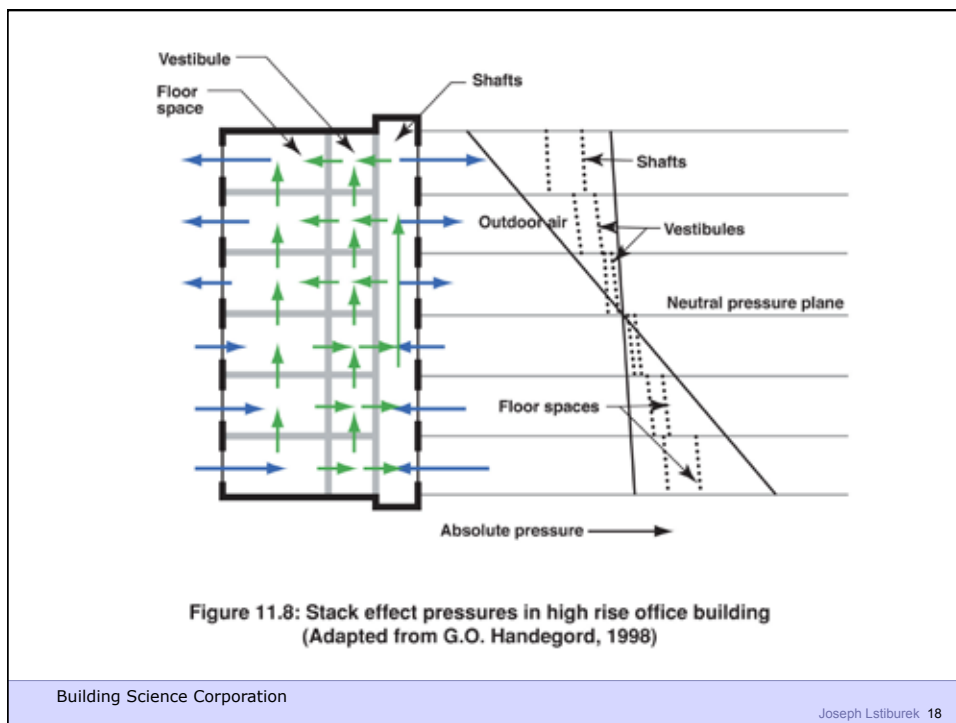
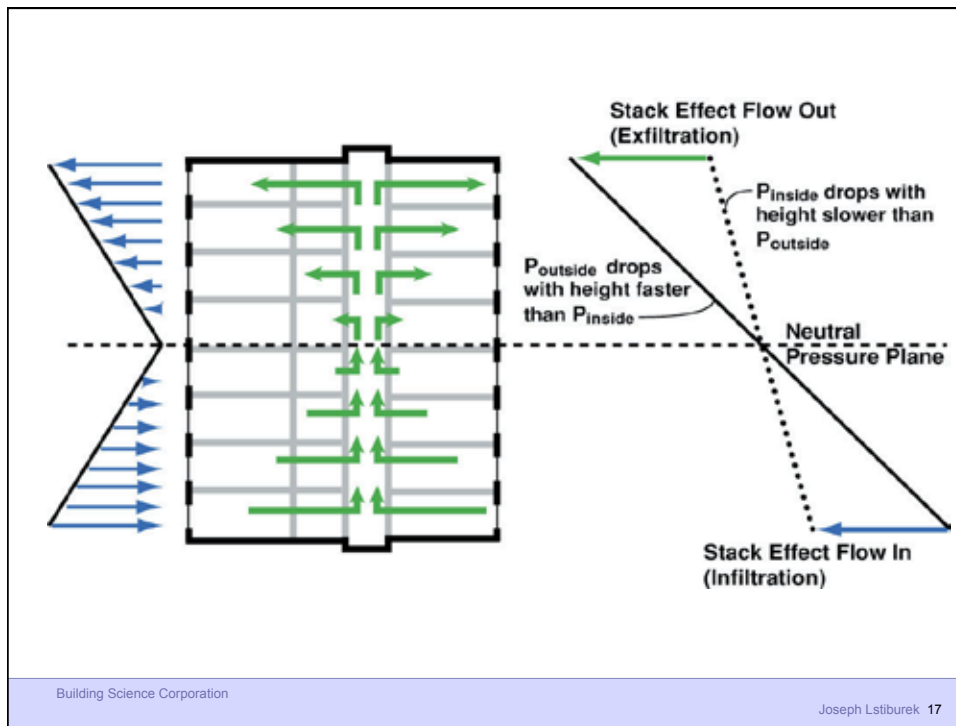

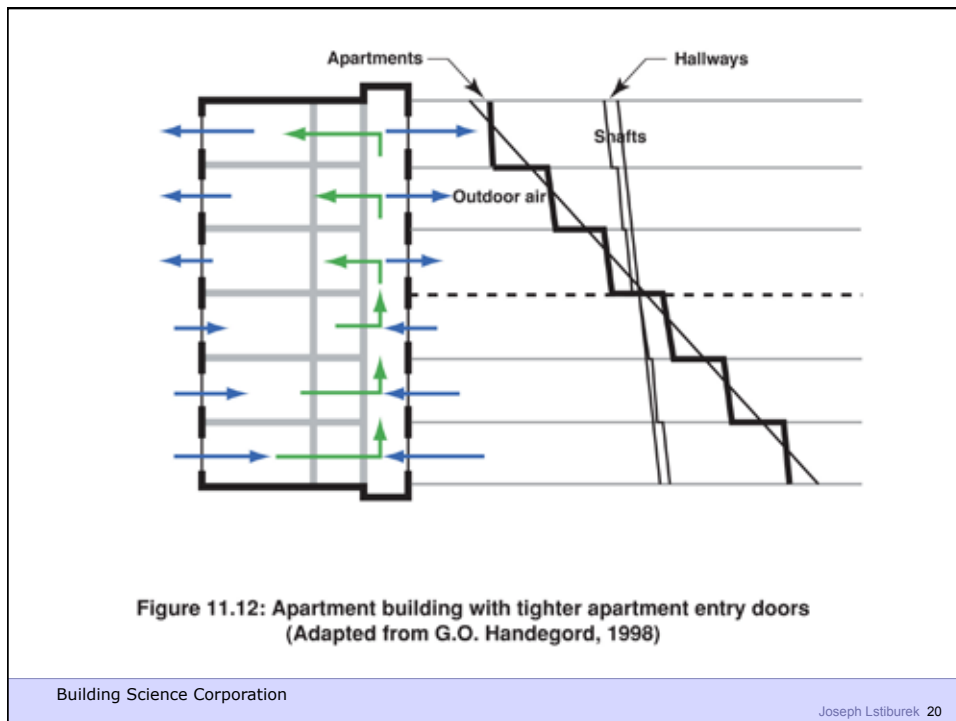
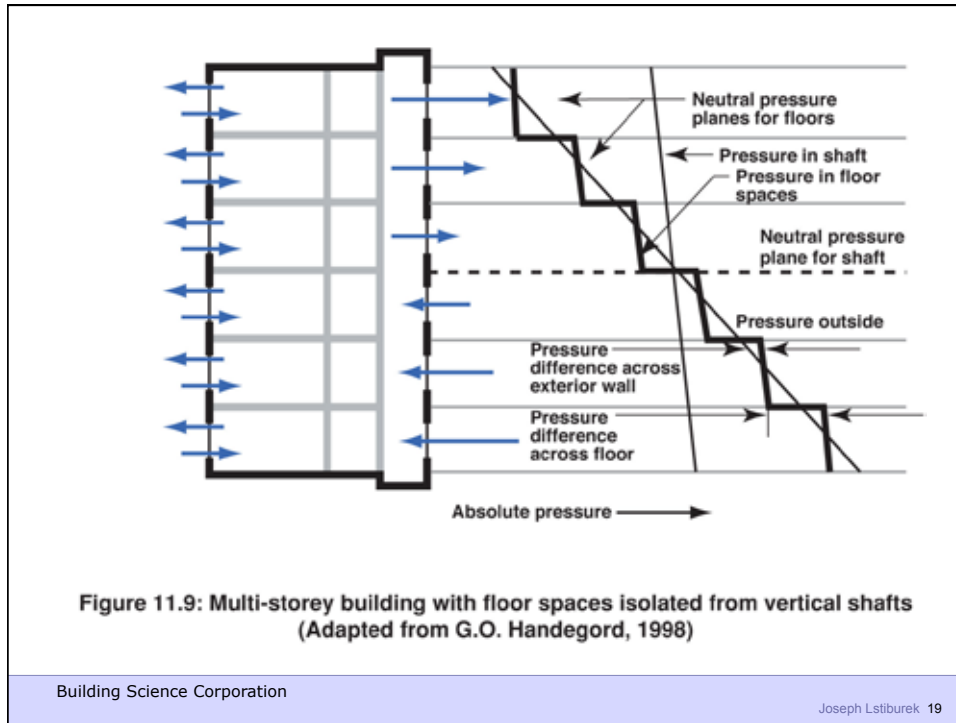

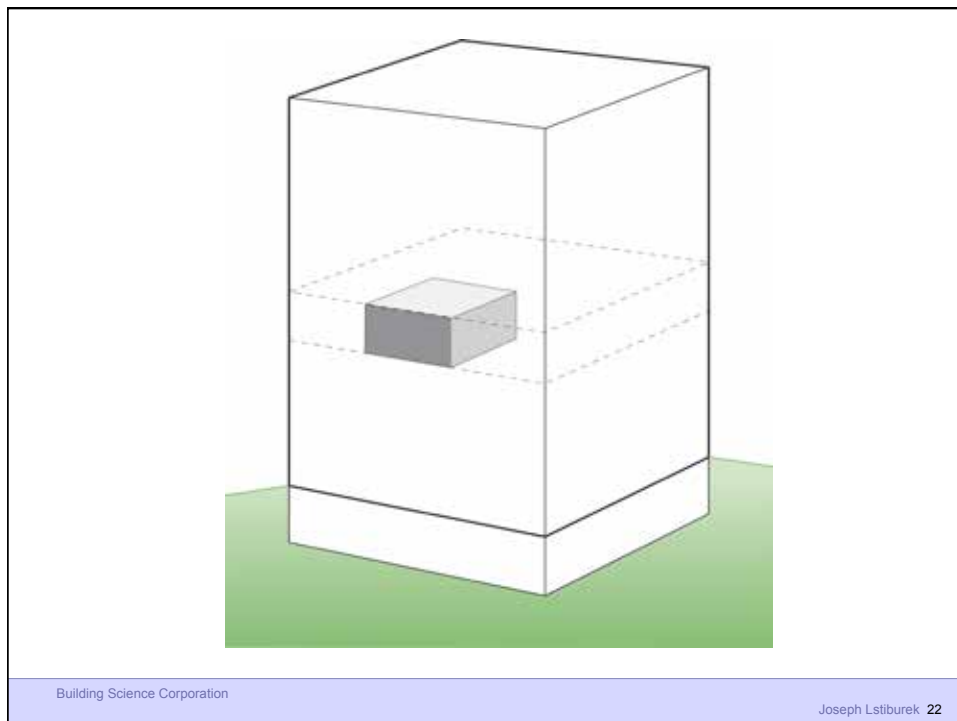
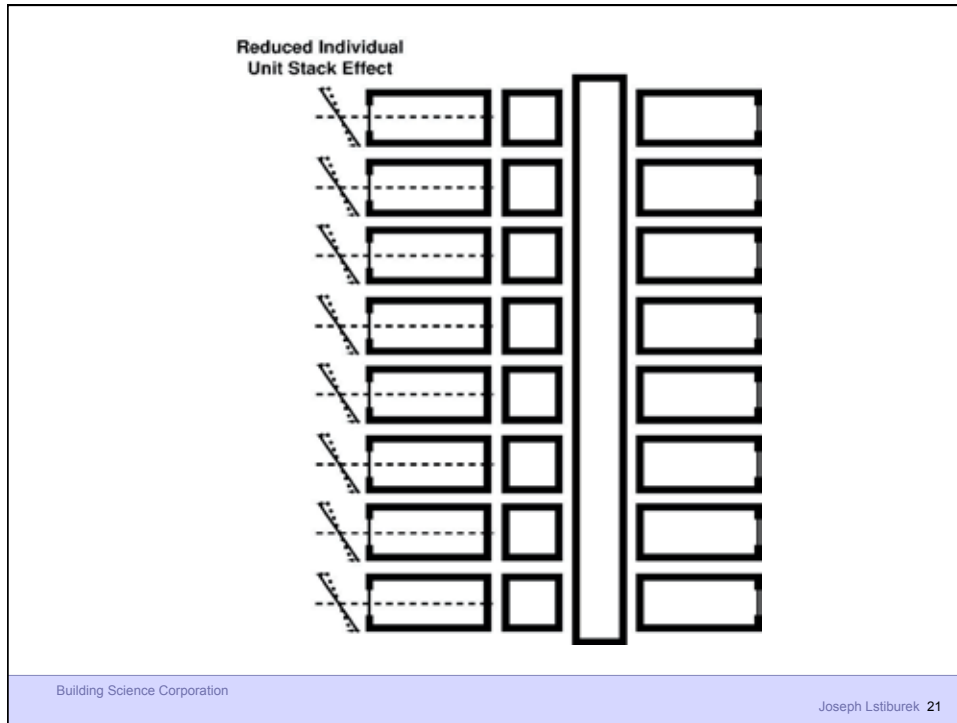



Building Science Corporation

Joseph Lstiburek – HVAC 23



Building Science Corporation

Joseph Lstiburek – HVAC 24

Figure 3.12
Ductwork and Air Handlers in Basements

- No air pressure differences result in a house with an air handler and ductwork located in a basement if there are no leaks in the supply ducts, the return ducts or the air handler and if the amount of air delivered to each room equals the amount removed

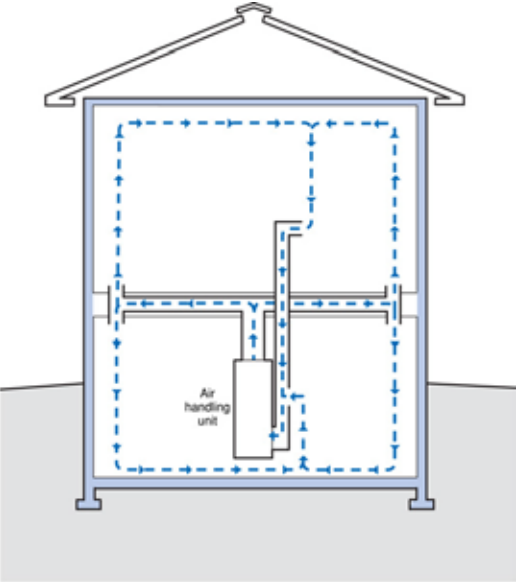

Building Science Corporation

Joseph Lstiburek – Airflow 25

Figure 3.13
Ductwork and Air Handlers in Vented Attics

- No air pressure differences result in a house with an air handler and ductwork located in a vented attic if there are no leaks in the supply ducts, the return ducts or the air handler and if the amount of air delivered to each room equals the amount removed

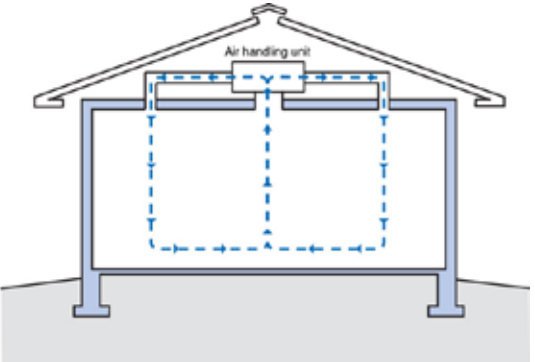

Building Science Corporation

Joseph Lstiburek – Airflow 26

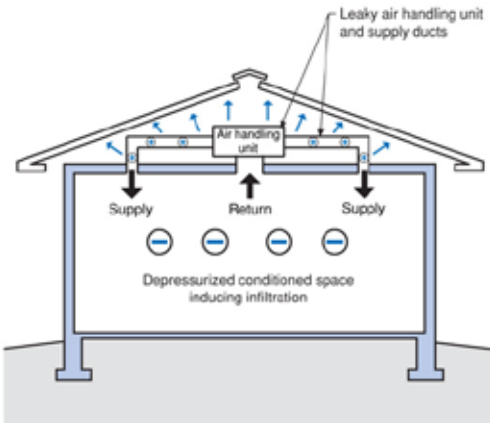

Figure 3.15
Leaky Ductwork and Air Handlers in Vented Attics

- Supply ductwork and air handler leakage is typically 20% or more of the flow through the system

Building Science Corporation

Joseph Lstiburek – Airflow 27



Building Science Corporation

Joseph Lstiburek – Airflow 28





Building Science Corporation



Building Science Corporation

Duct Leakage Should Be Less Than 5% of Rated Flow As Tested By Pressurization To 25 Pascals

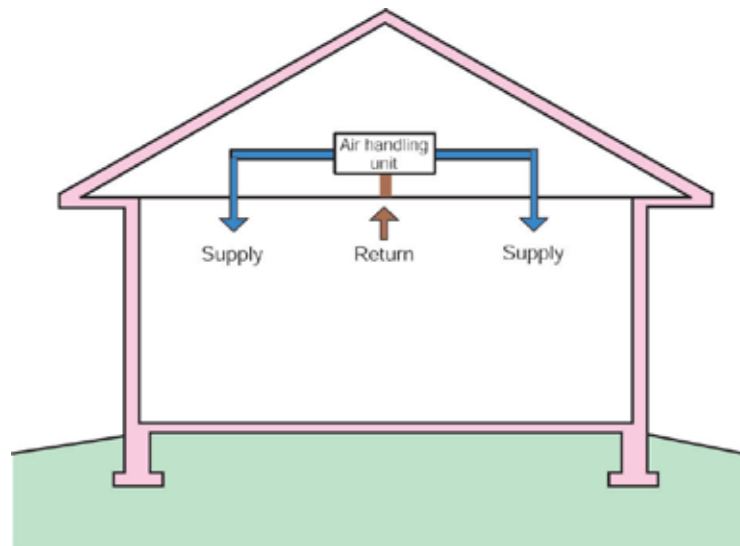

Note: Colored shading depicts the building's thermal barrier and pressure boundary. The thermal barrier and pressure boundary enclose the conditioned space.

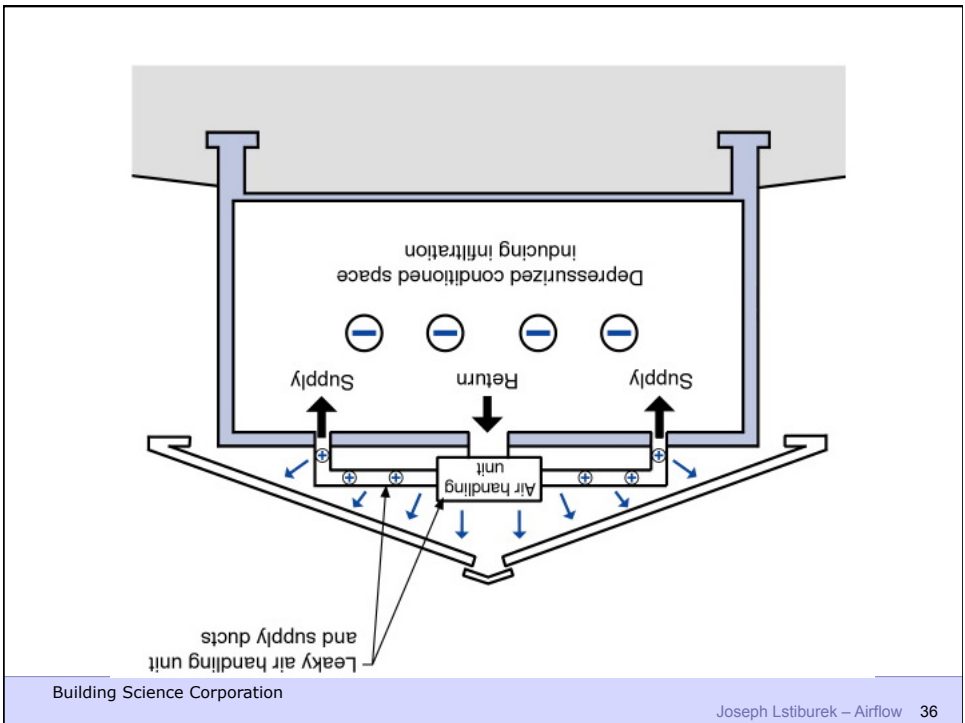
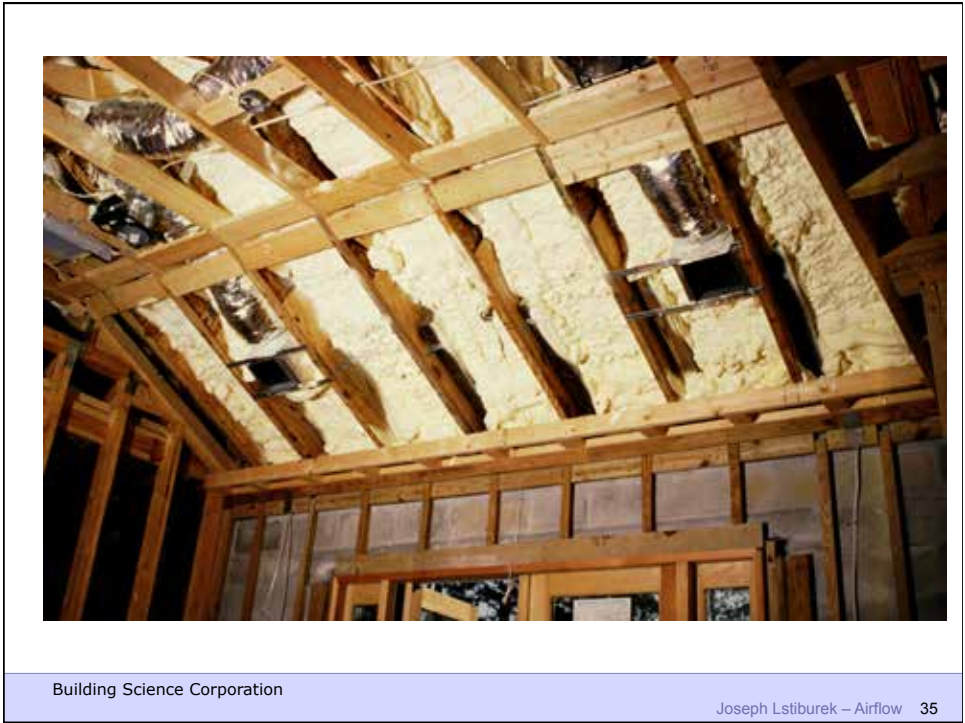

Figure 3.16
Leaky Supply Ductwork in Vented Crawl Space

- Air pressurization pattern with mechanical system ducts in the crawl space

The diagram illustrates a cross-section of a house with a gabled roof. The interior is labeled as a 'Depressurized conditioned space' and contains an 'Air handling unit' with 'Supply' and 'Return' registers. Blue arrows show air being pushed from the supply registers into the walls. On the exterior side, blue arrows labeled 'Leaky supply ducts' show air escaping through the walls. Below the house, a 'Crawl space' is shown with blue arrows indicating air being drawn into the crawl space from the leaks. The crawl space is vented to the outside.

Building Science Corporation

Joseph Lstiburek – Airflow 37

A photograph showing a window in a house with green horizontal siding and a white baseboard. The area around the window is heavily stained with dark, irregular patches, likely mold or water damage. Green bushes are visible in the foreground.

Building Science Corporation

Joseph Lstiburek – Airflow 38



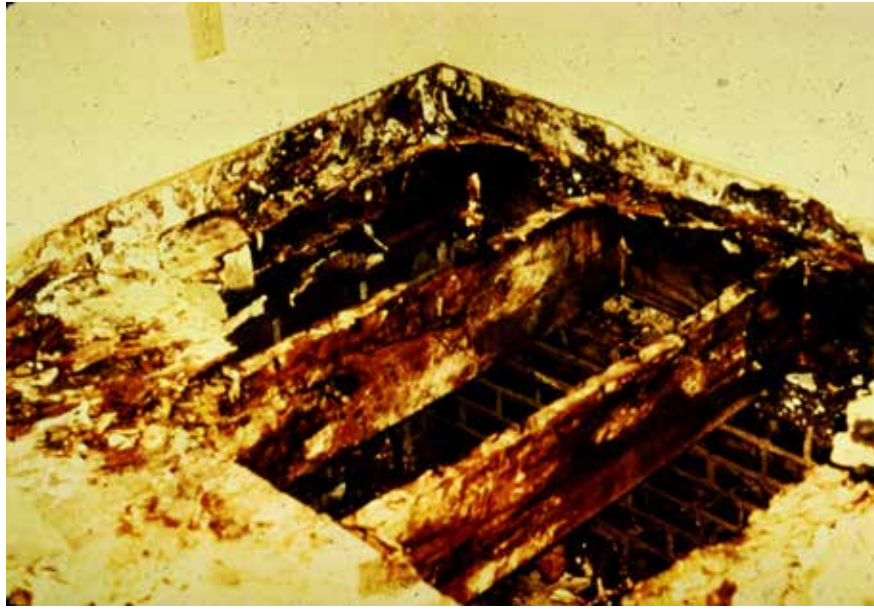

Building Science Corporation



Building Science Corporation

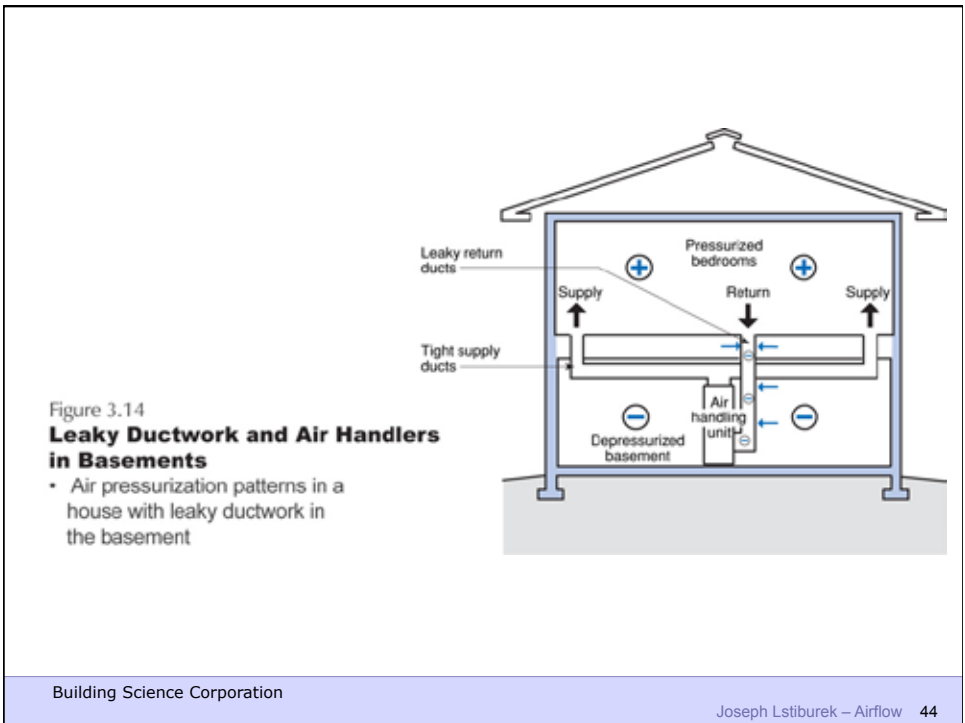

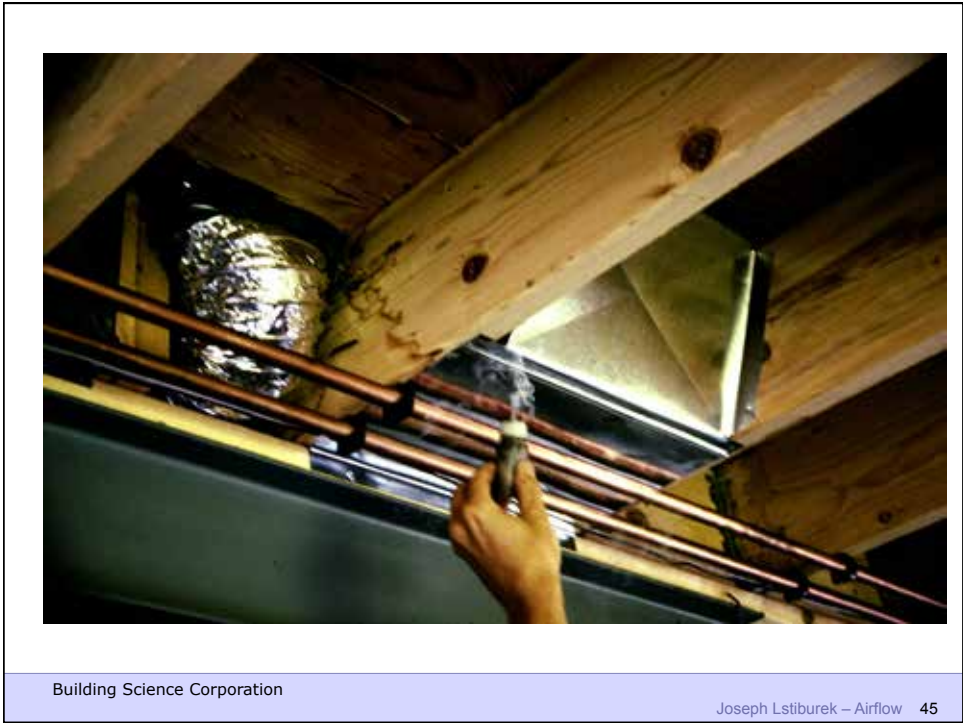



Building Science Corporation



Building Science Corporation



Building Science Corporation



Building Science Corporation

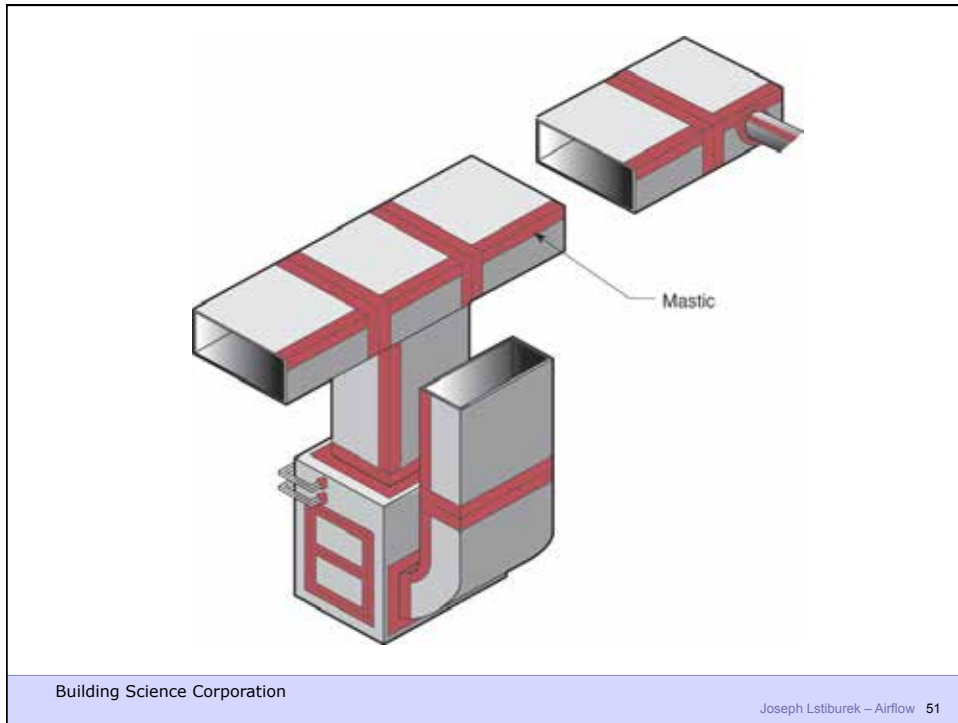



Building Science Corporation

Joseph Lstiburek – Airflow 53

Figure 3.18

Insufficient Return Air Paths

- Pressurization of bedrooms often occurs if insufficient return pathways are provided; undercutting bedroom doors is usually insufficient; transfer grilles, jump ducts or fully ducted returns may be necessary to prevent pressurization of bedrooms
- Master bedroom suites are often the most pressurized as they typically receive the most supply air
- When bedrooms pressurize, common areas depressurize; this can have serious consequences when fireplaces are located in common areas and subsequently backdraft

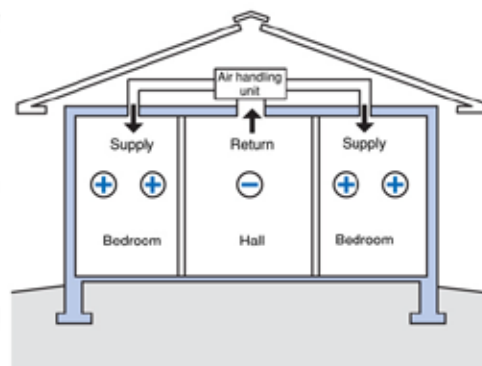

Building Science Corporation

Joseph Lstiburek – Airflow 54

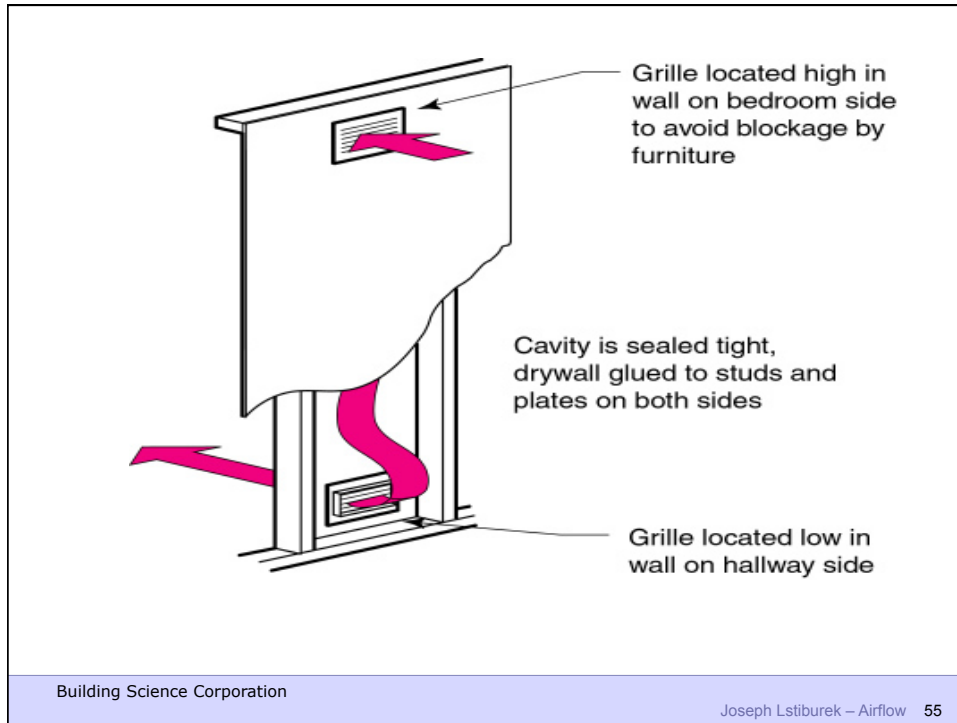

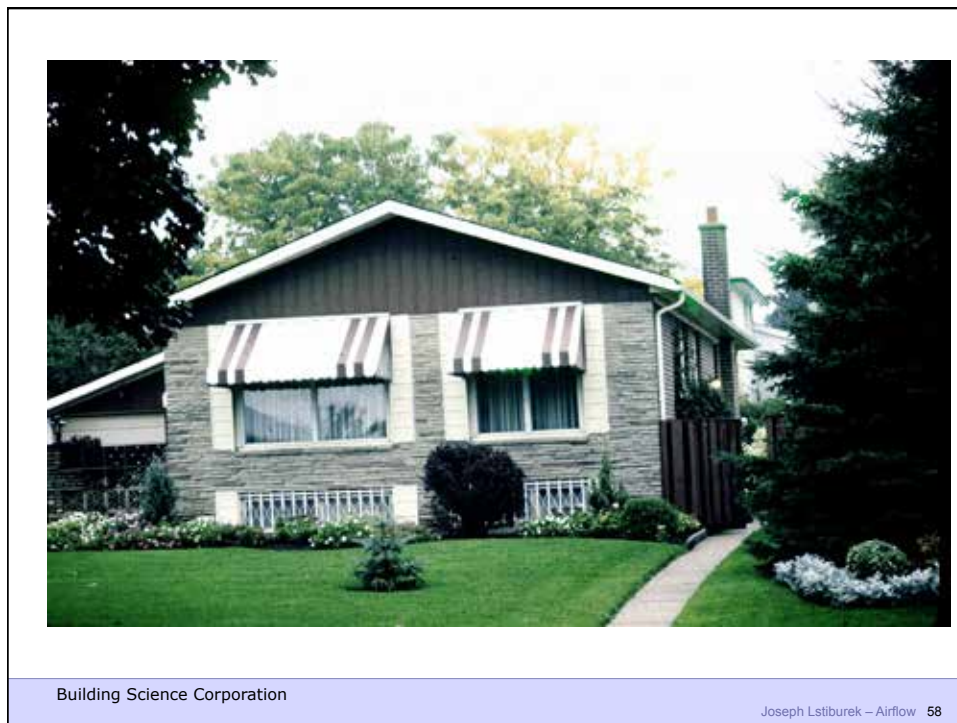
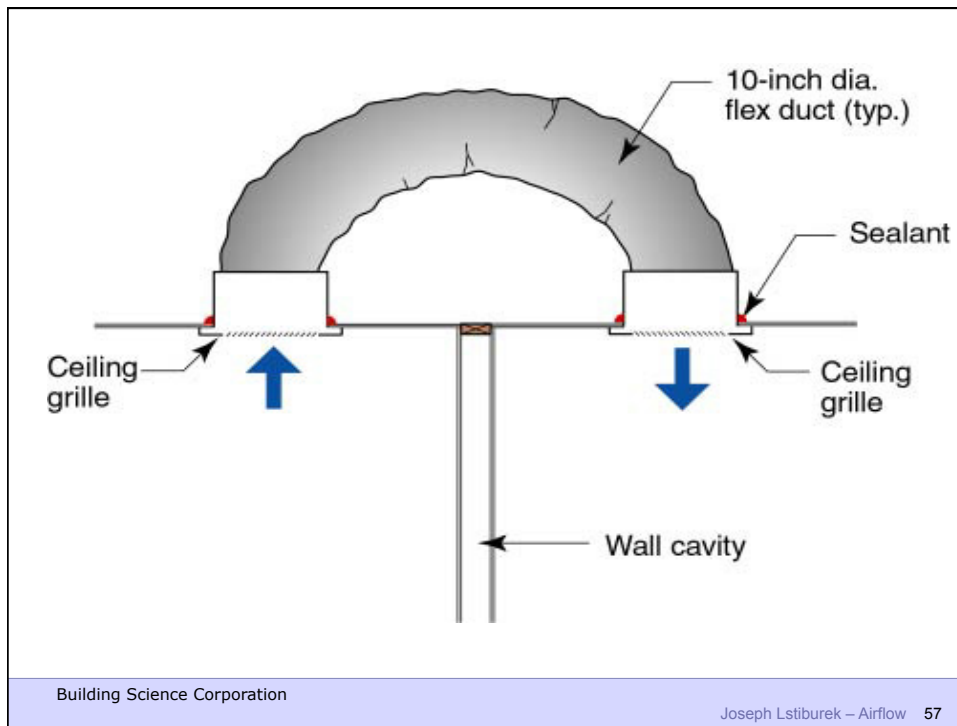

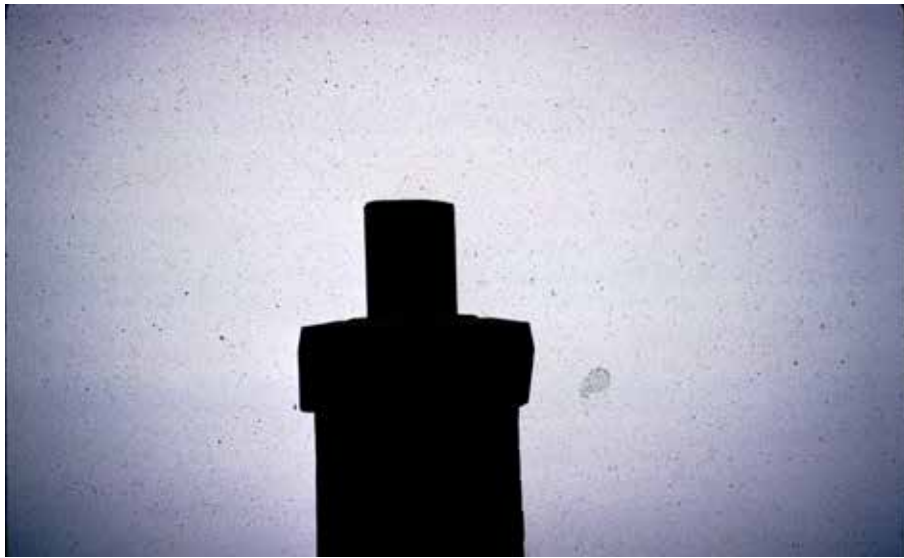

Building Science Corporation

Joseph Lstiburek – Airflow 59



Building Science Corporation

Joseph Lstiburek – Airflow 60



Building Science Corporation

Joseph Lstiburek – Airflow 61



Building Science Corporation

Joseph Lstiburek – Airflow 62

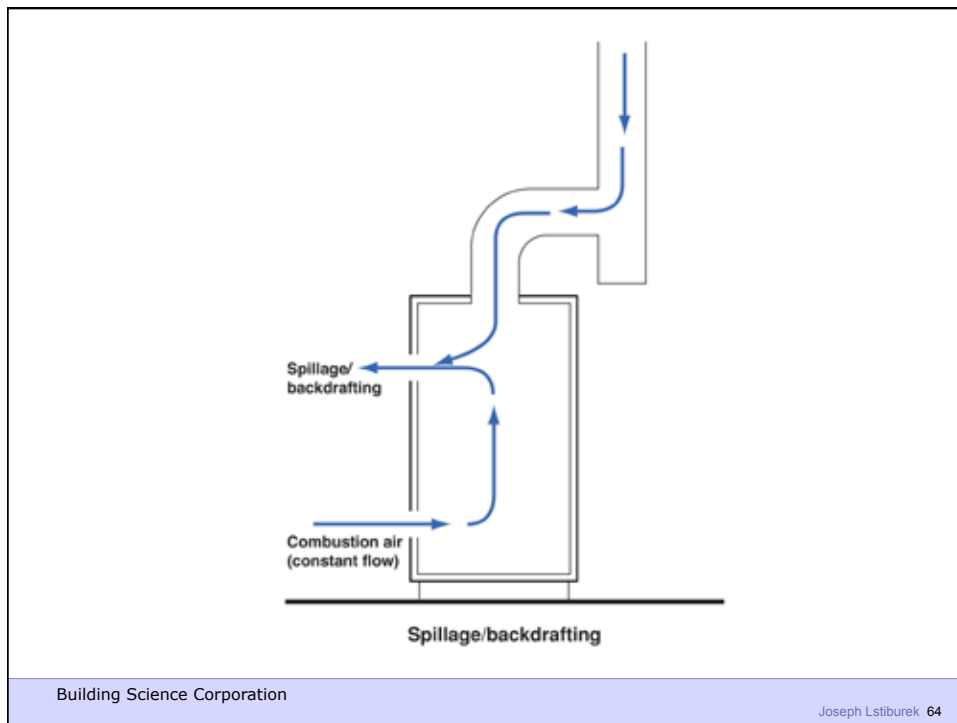
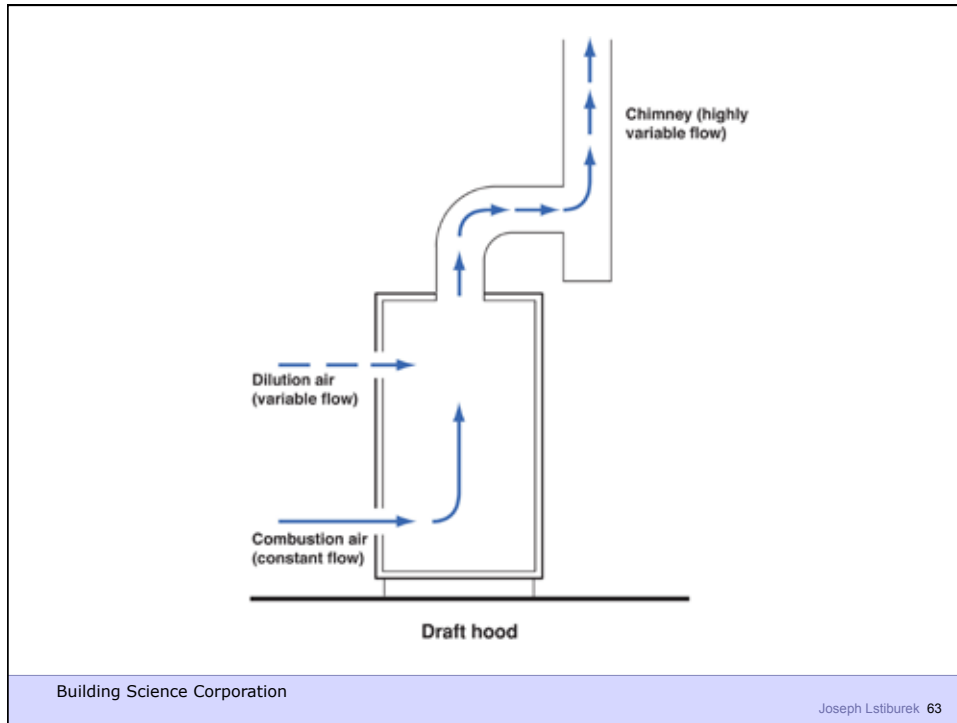



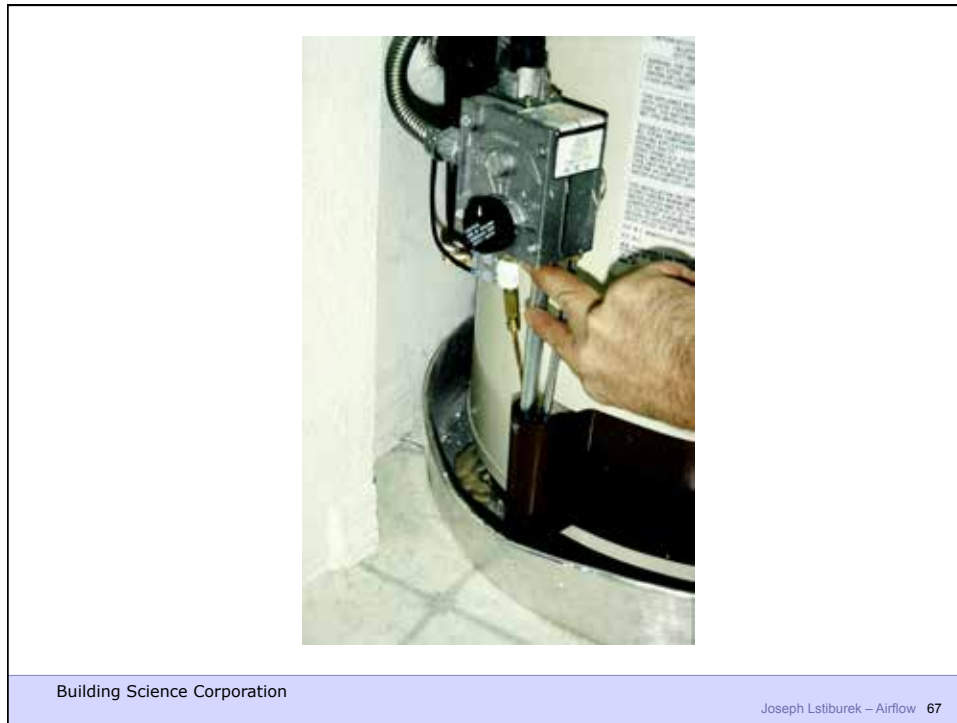

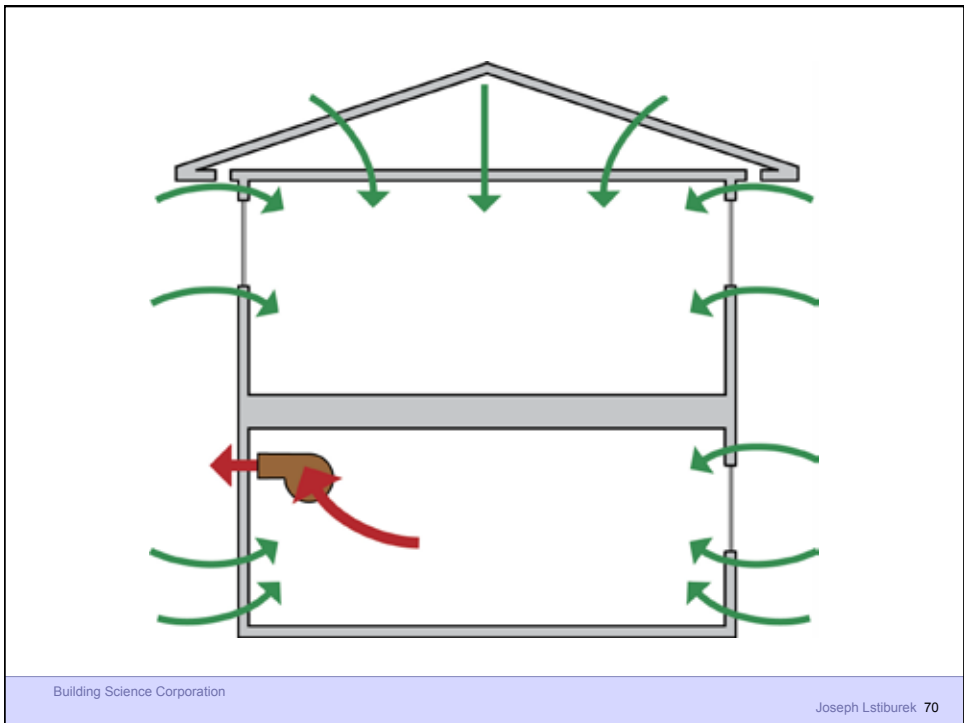
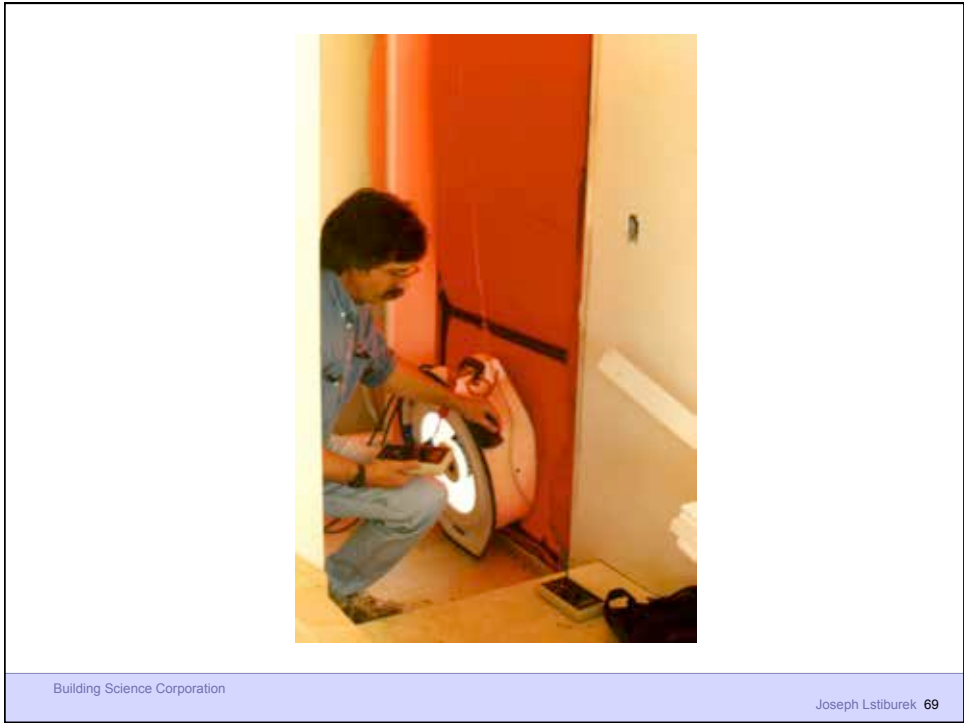

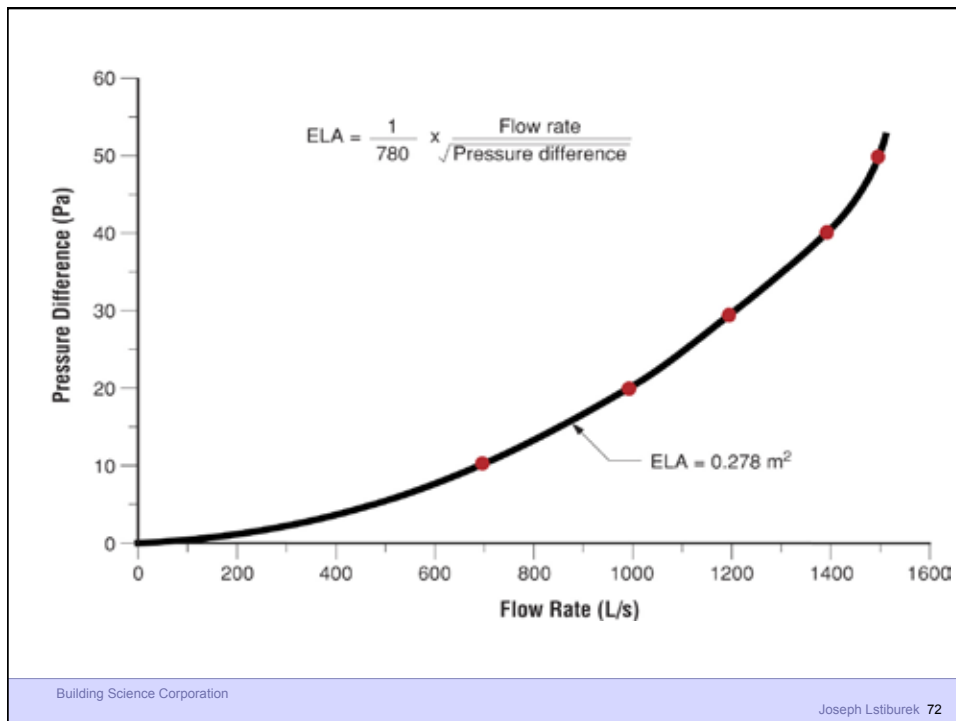
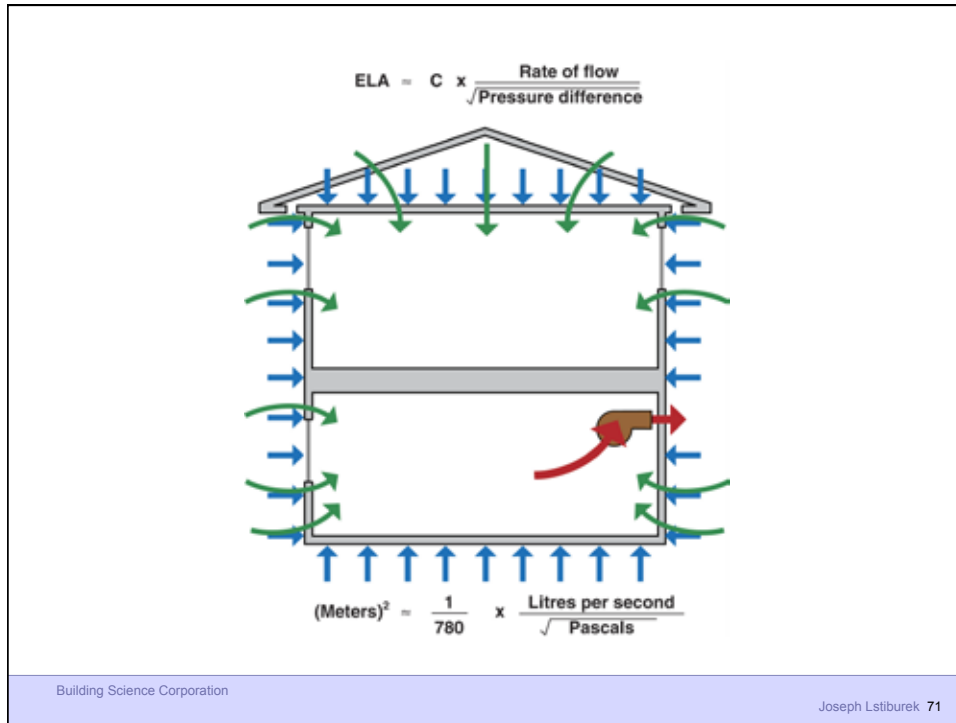

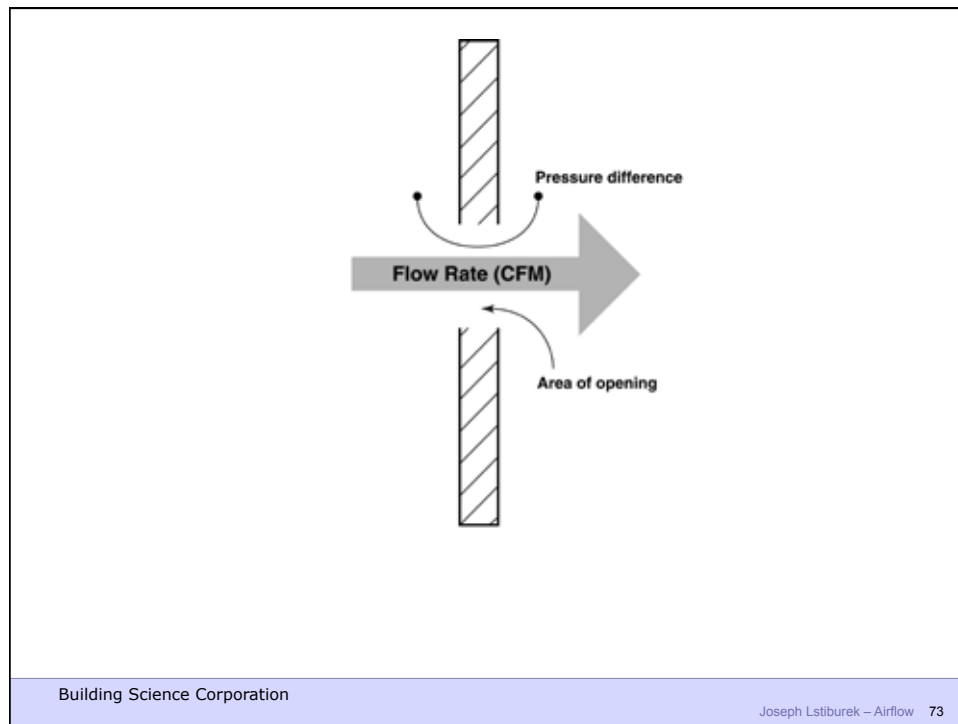

Flow Through Orifices

Turbulent Flow - “inertial effects”

Flow Through Porous Media

Laminar Flow - “viscosity effects”

Flow Through Orifices

Turbulent Flow - “inertial effects”

Flow Through Porous Media

Laminar Flow - “viscosity effects”

“true but not useful”

$$Q = A \cdot C_D \left[\frac{2}{\rho} (\Delta P) \right]^{\frac{1}{2}} \quad \text{Bernoulli}$$

$$Q = C_K \frac{\rho}{\mu} (\Delta P) \quad \text{Darcy}$$

$$Q = A \cdot C_D \left[\frac{2}{\rho} (\Delta P) \right]^{\frac{1}{2}} \quad \text{Bernoulli}$$

$$Q = C_K \frac{\rho}{\mu} (\Delta P) \quad \text{Darcy}$$

$$Q = A \cdot C (\Delta P)^{\frac{1}{2}}$$

$$Q = C (\Delta P)$$

$$Q = A \cdot C_D \left[\frac{2}{\rho} (\Delta P) \right]^{\frac{1}{2}} \quad \text{Bernoulli}$$

$$Q = C_K \frac{\rho}{\mu} (\Delta P) \quad \text{Darcy}$$

$$Q = A \cdot C (\Delta P)^{\frac{1}{2}}$$

$$Q = C (\Delta P)$$

$$Q = A \cdot C (\Delta P)^n \quad \text{Kronval "an engineer"}$$

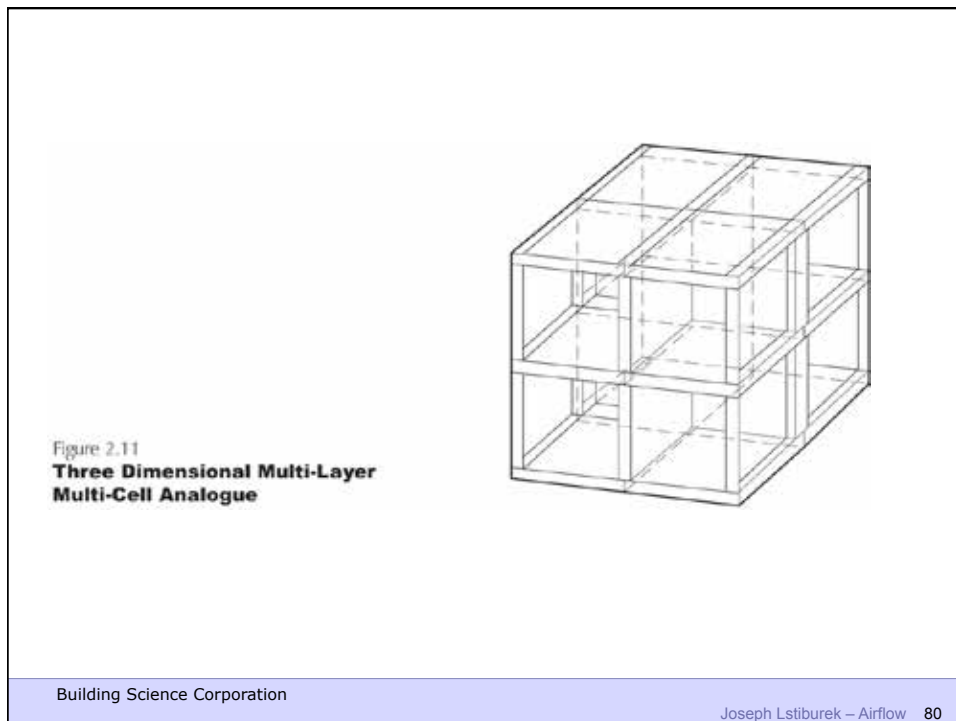
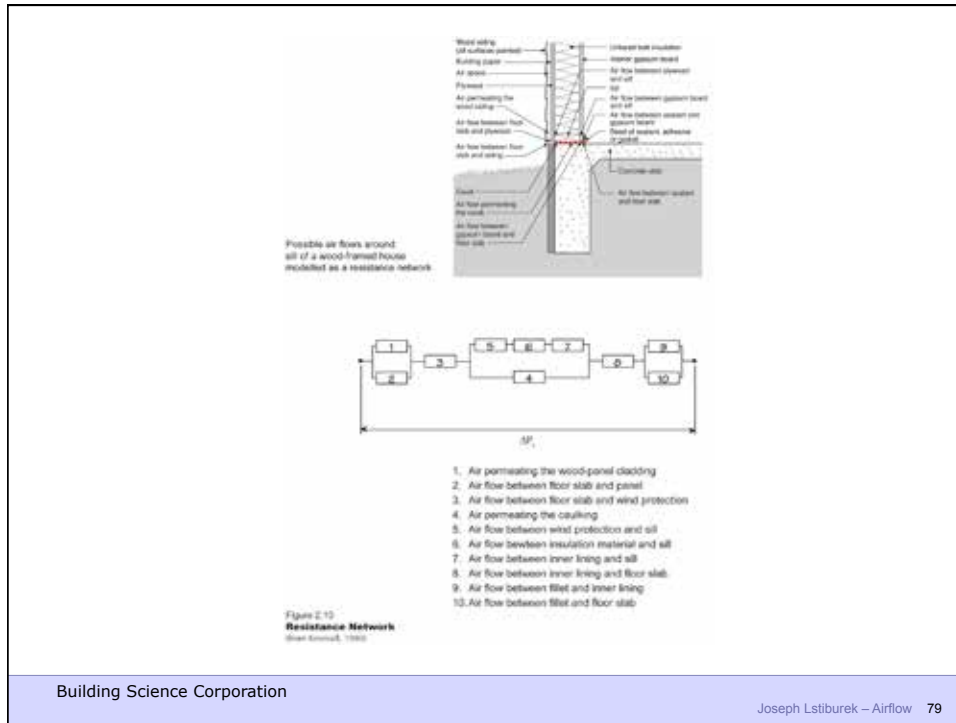

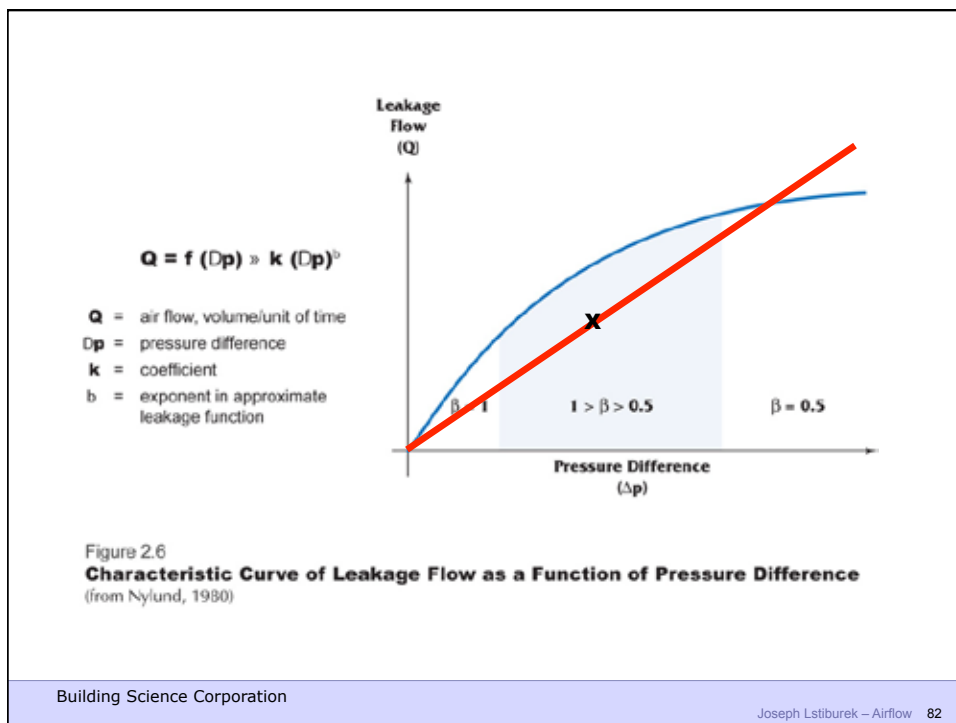
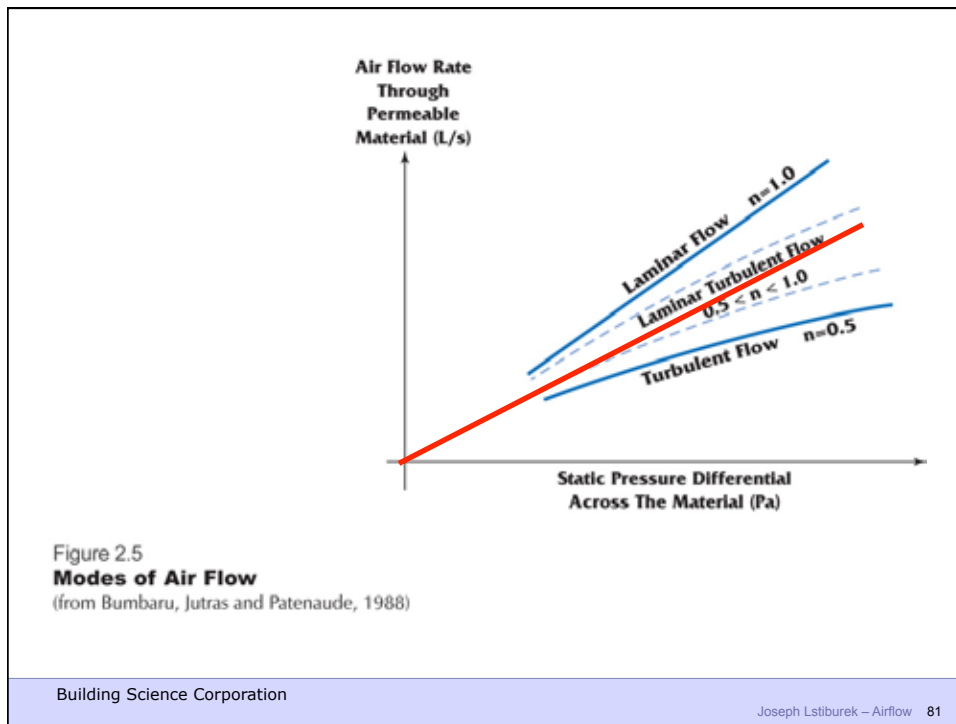

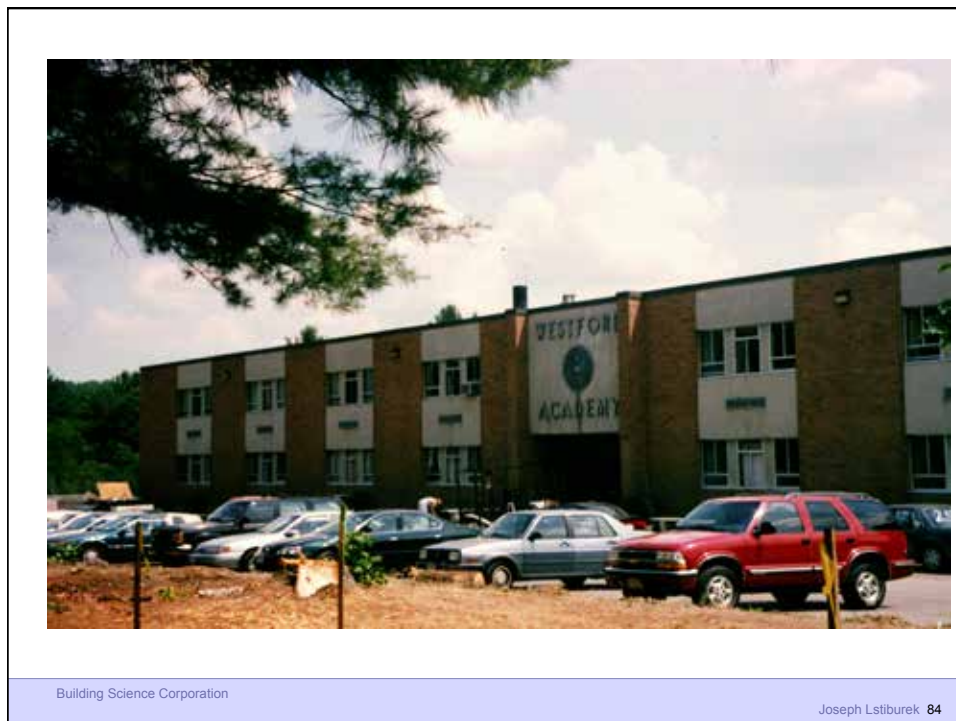
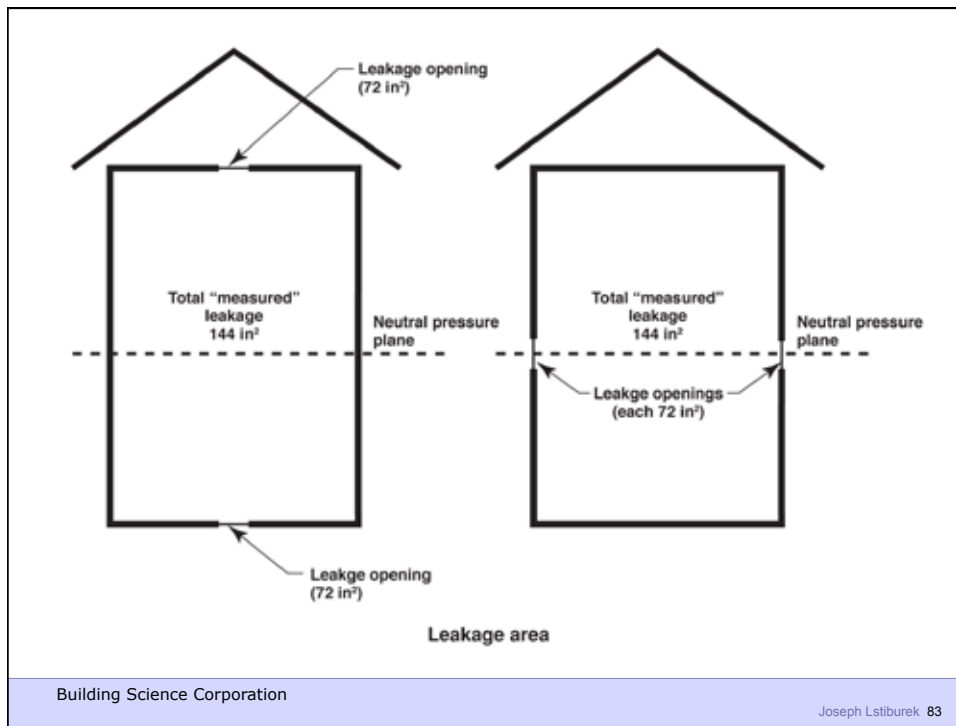

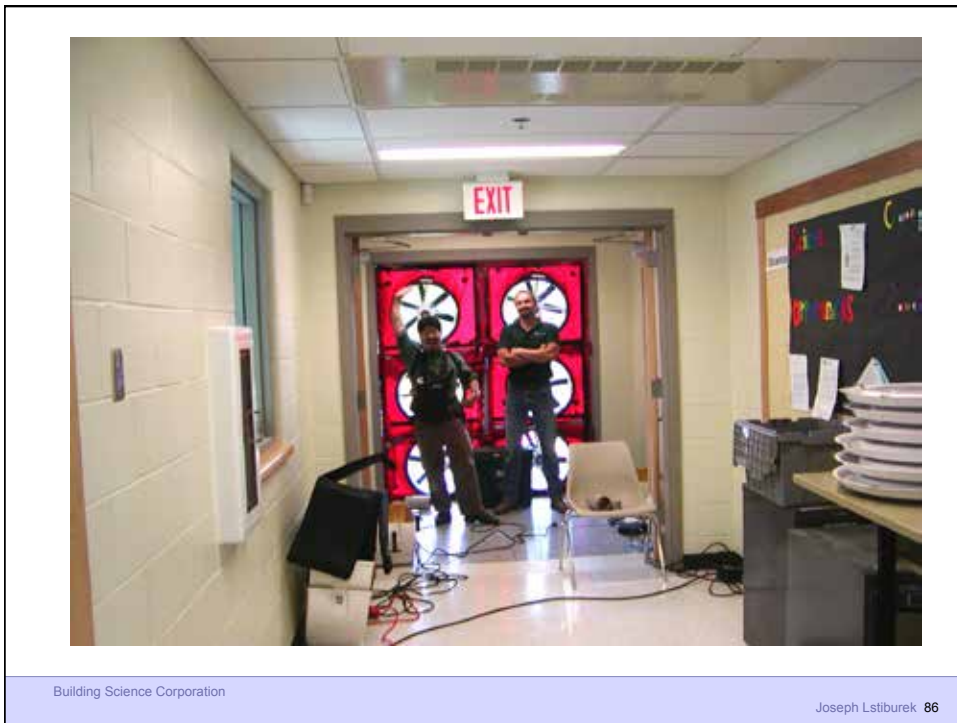

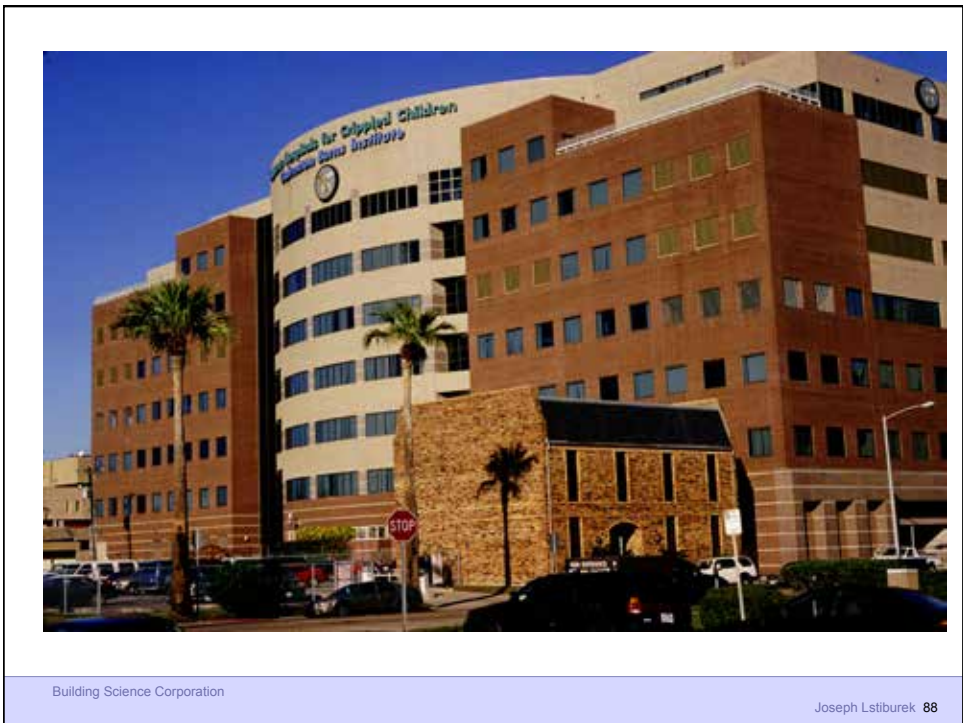



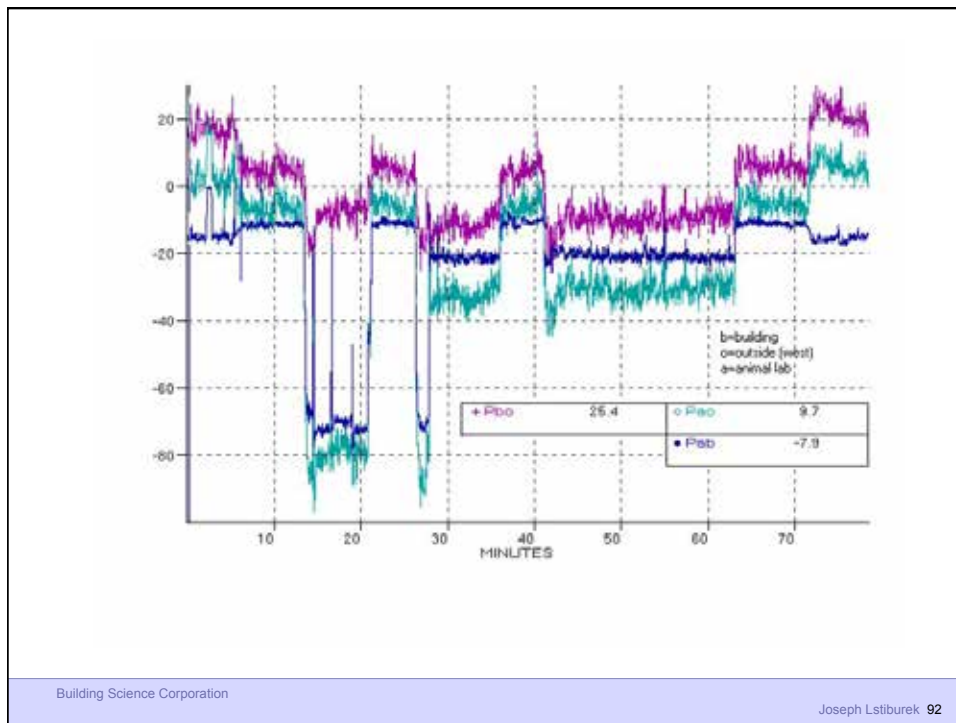
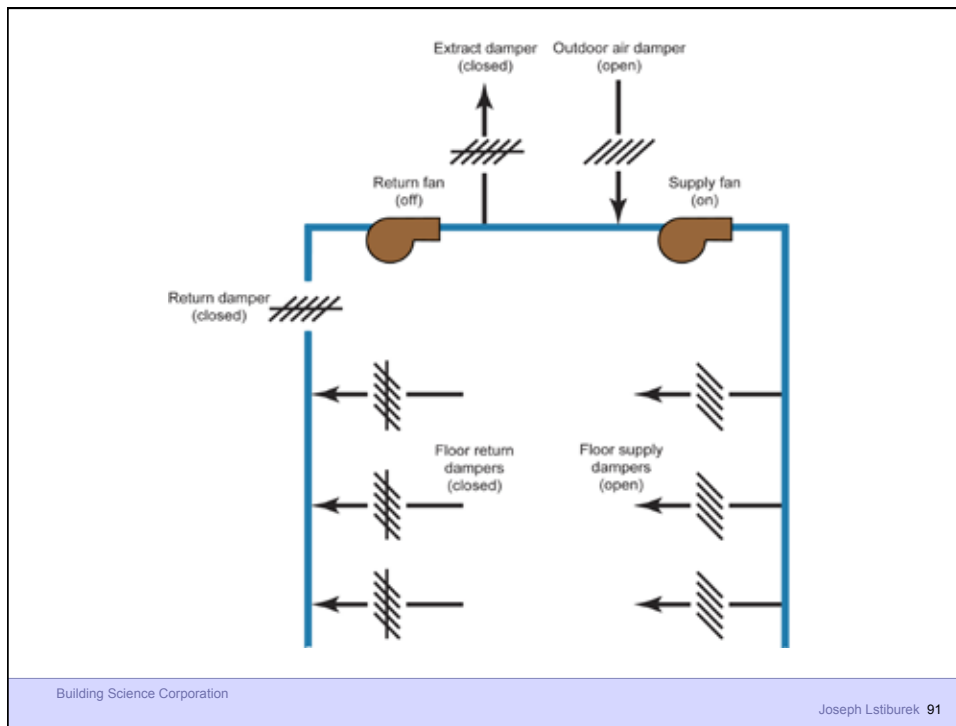

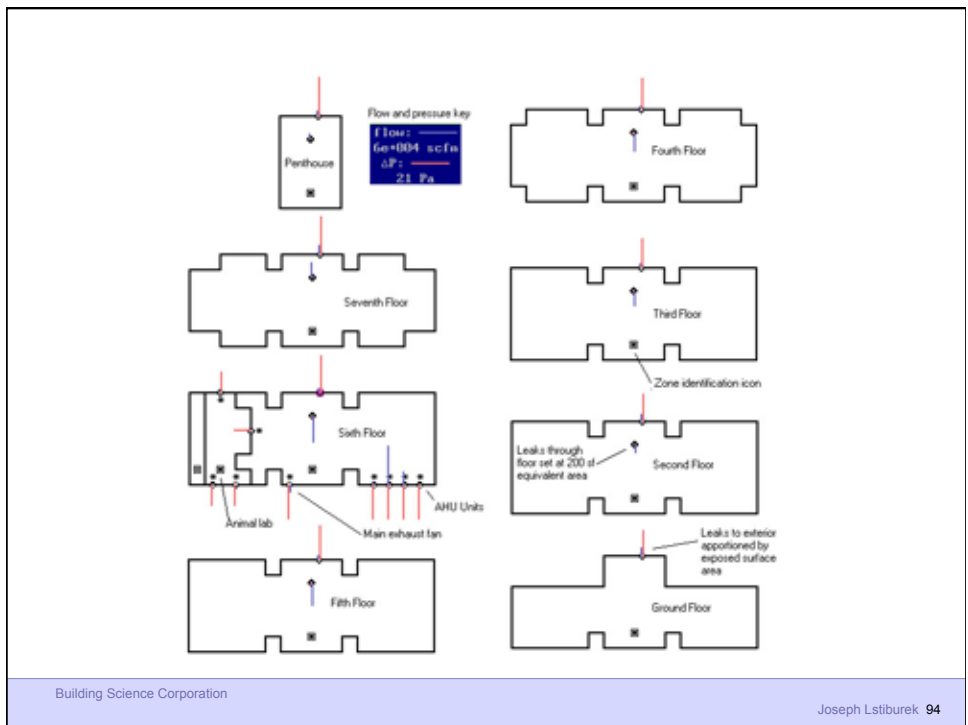
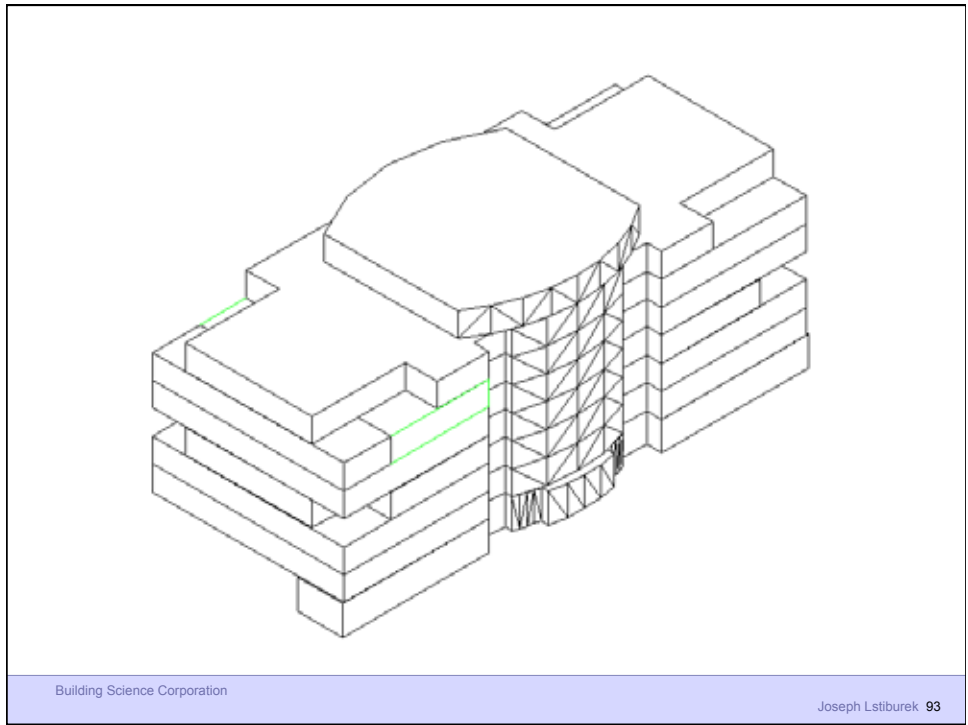

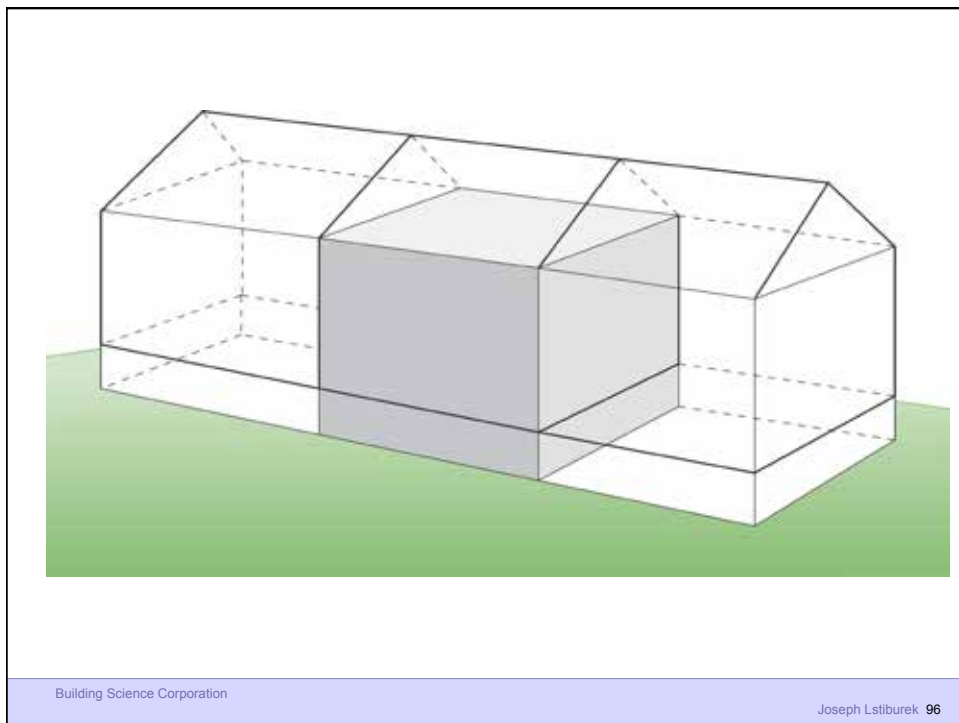
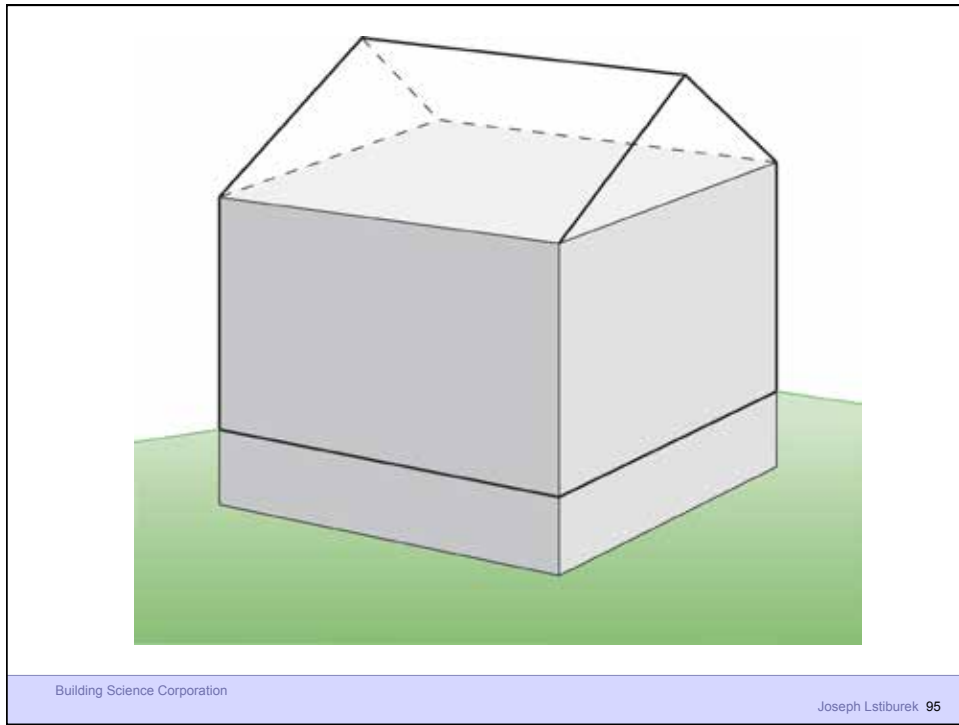

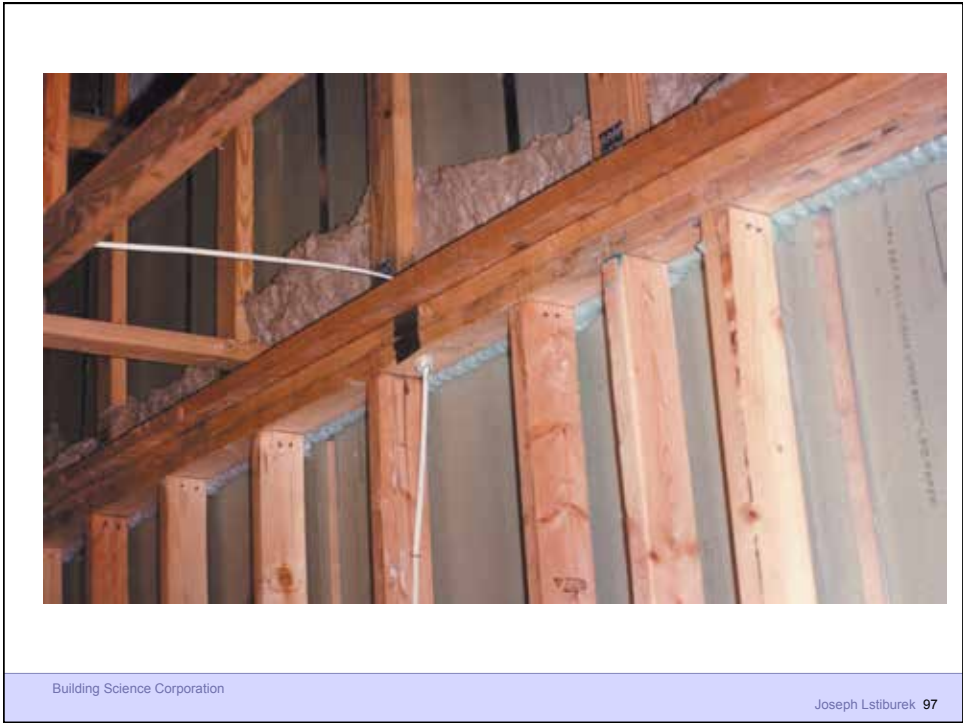

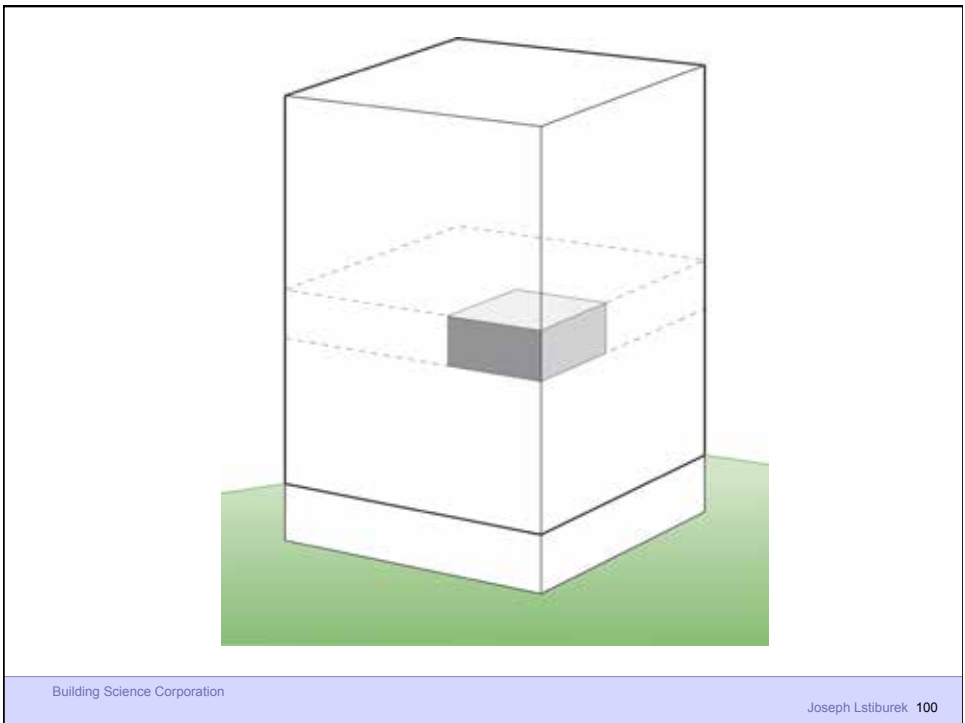

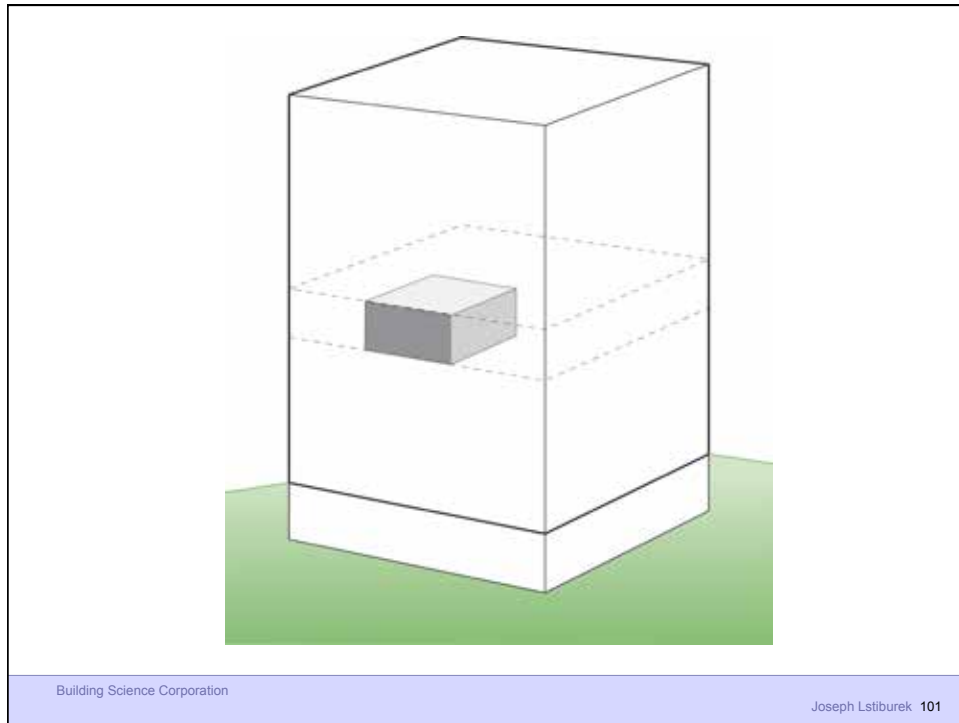

Three Types of Controlled Ventilation Systems

- Exhaust Ventilation
- Supply Ventilation
- Balanced Ventilation

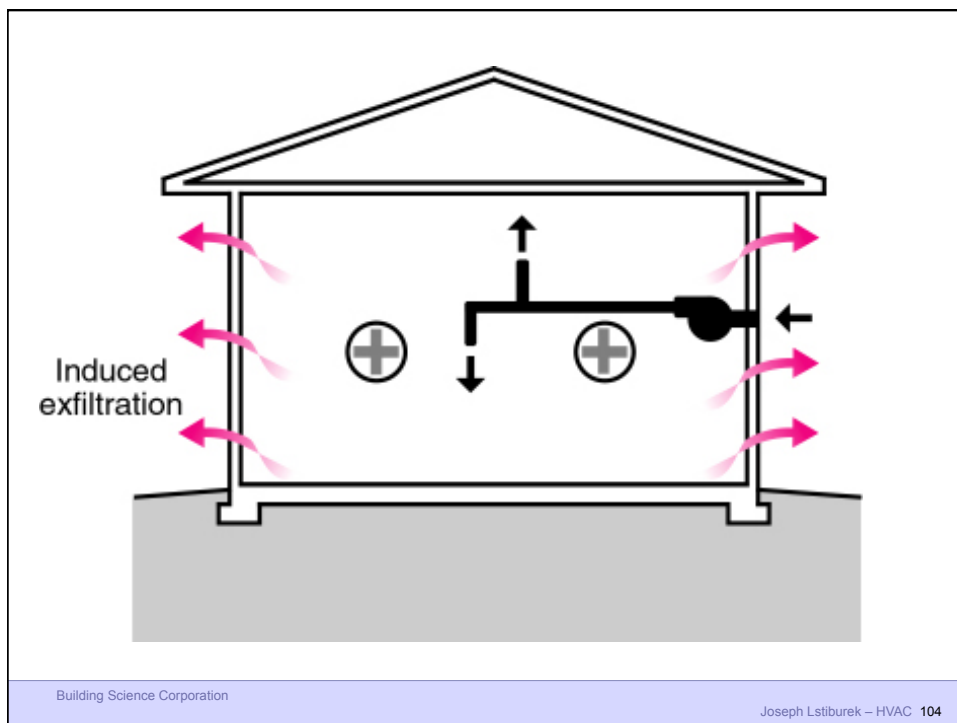
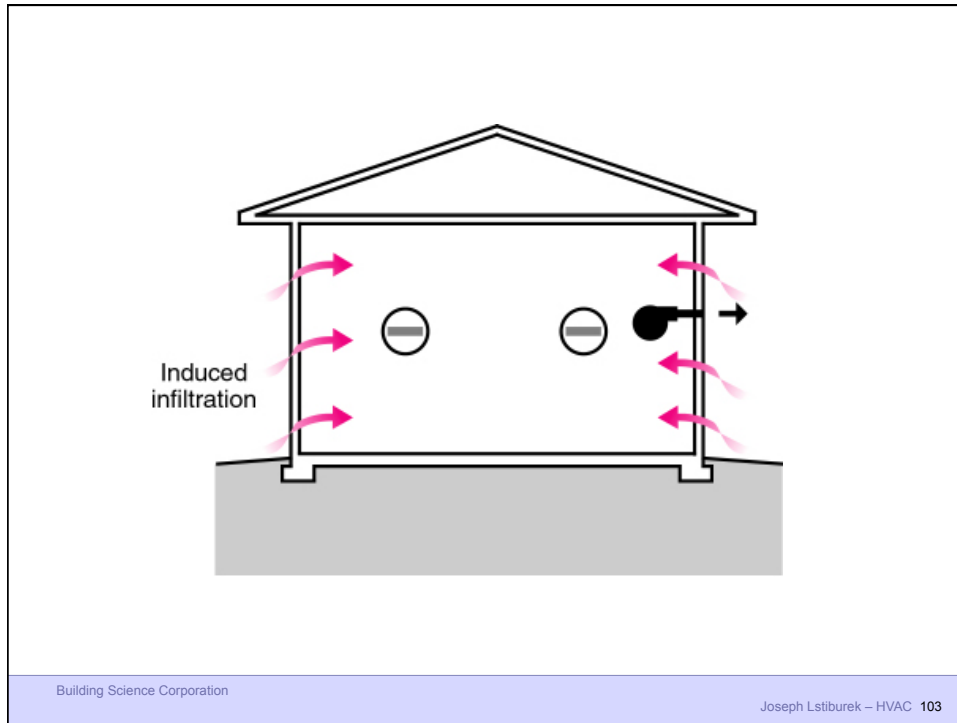

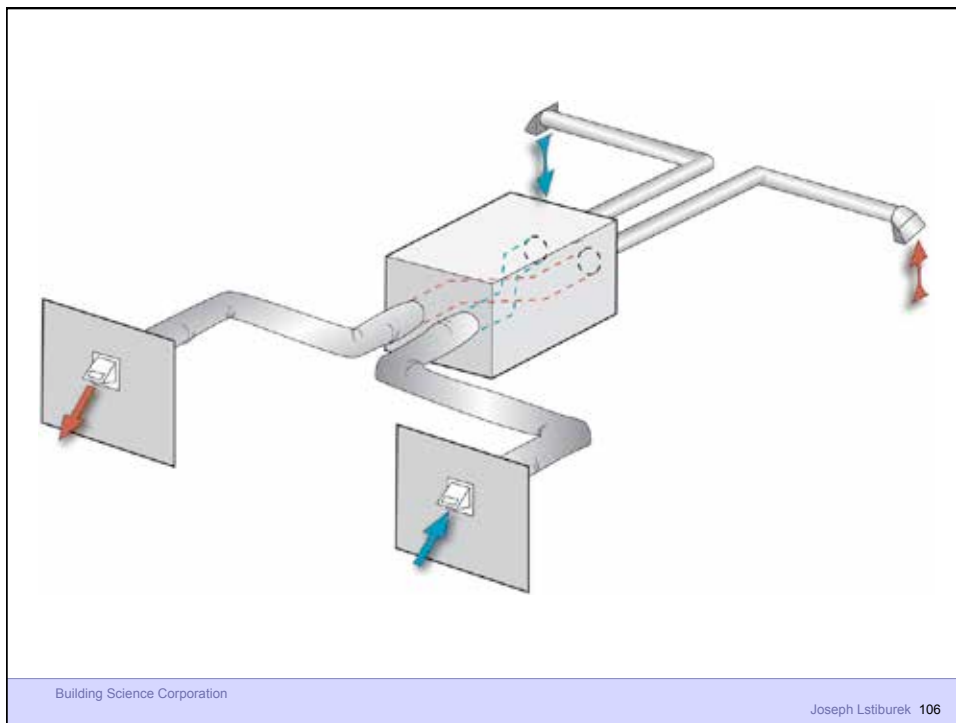
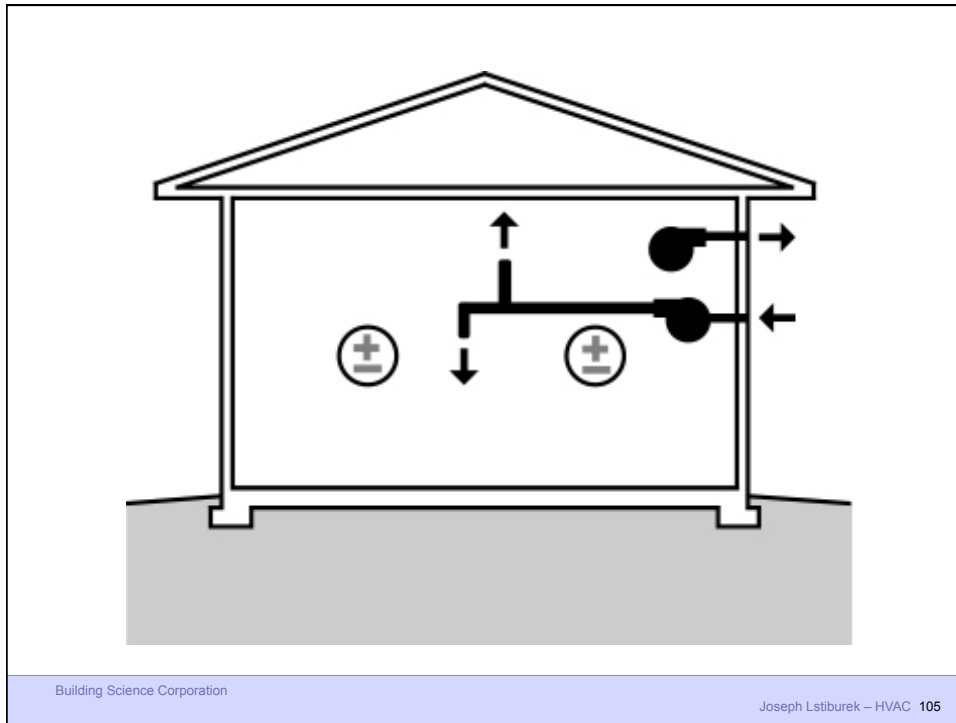

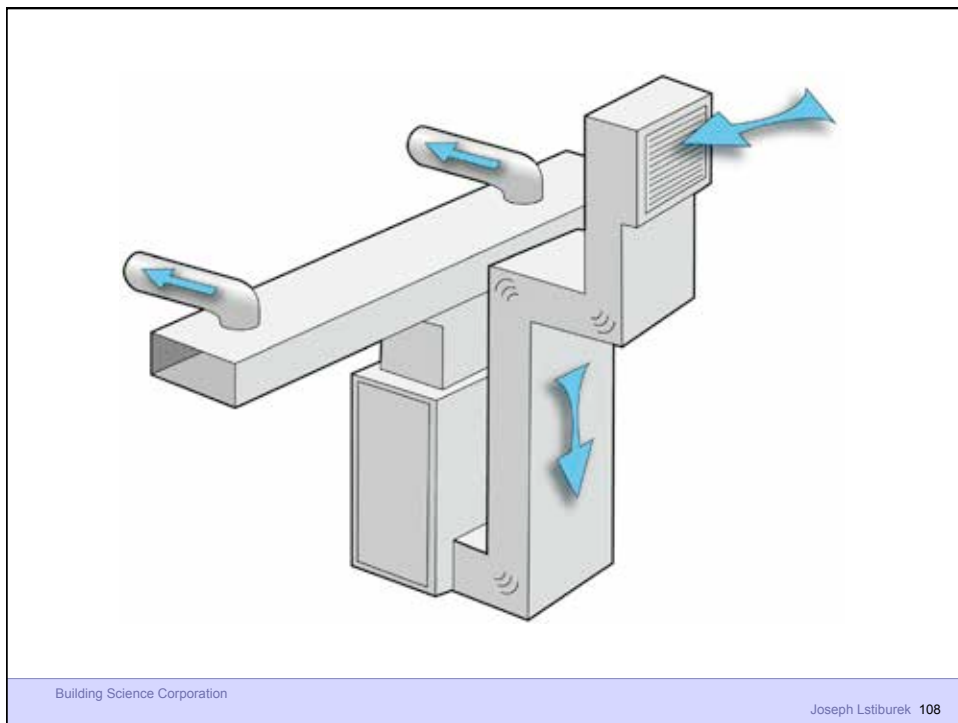
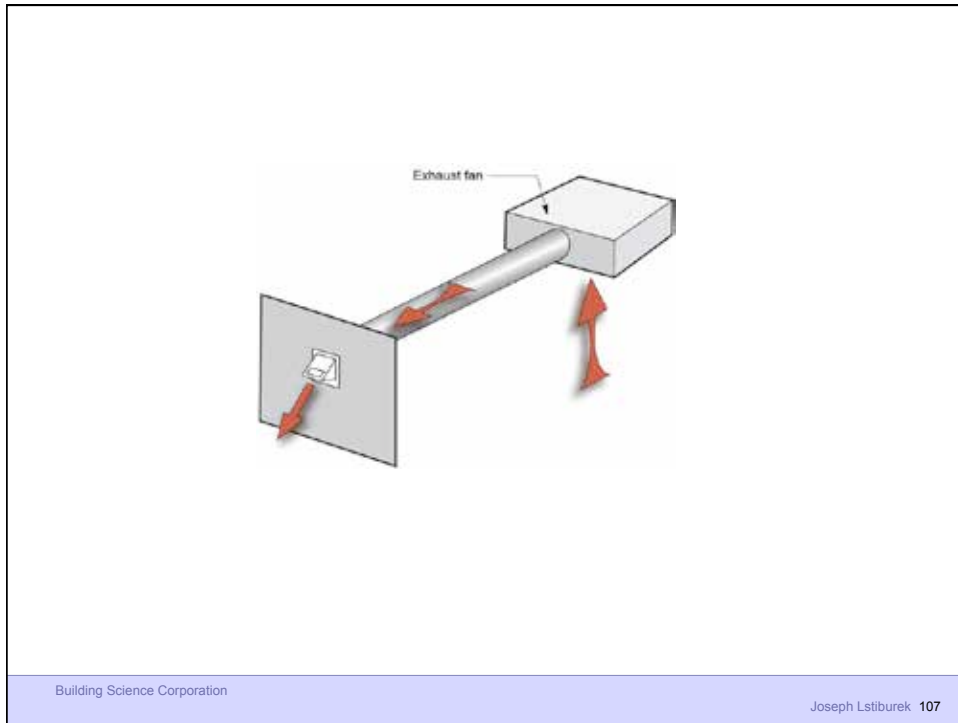

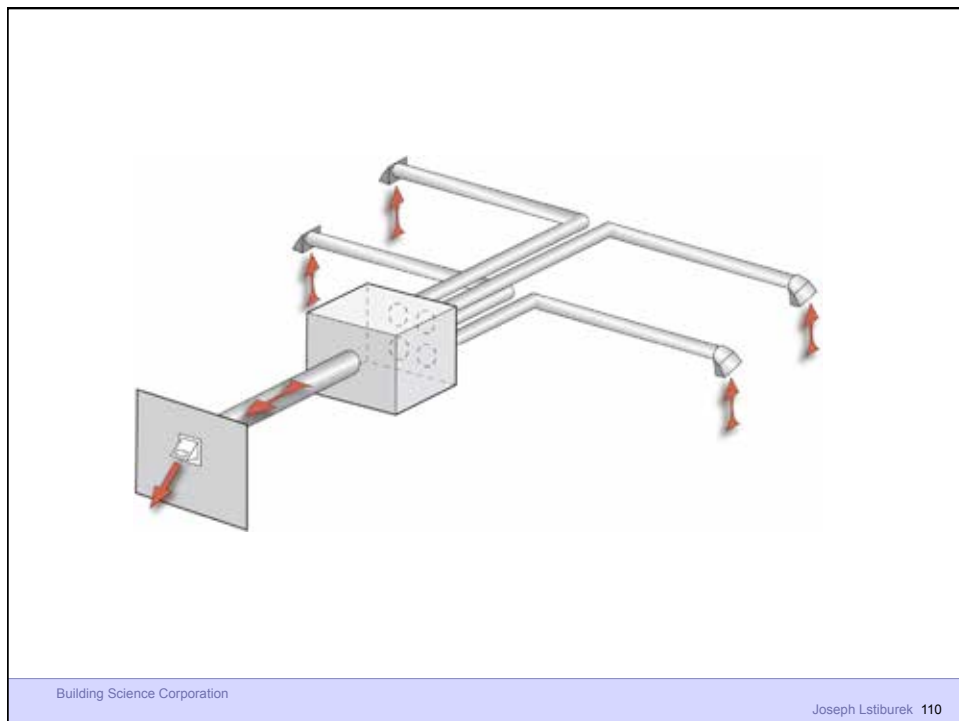
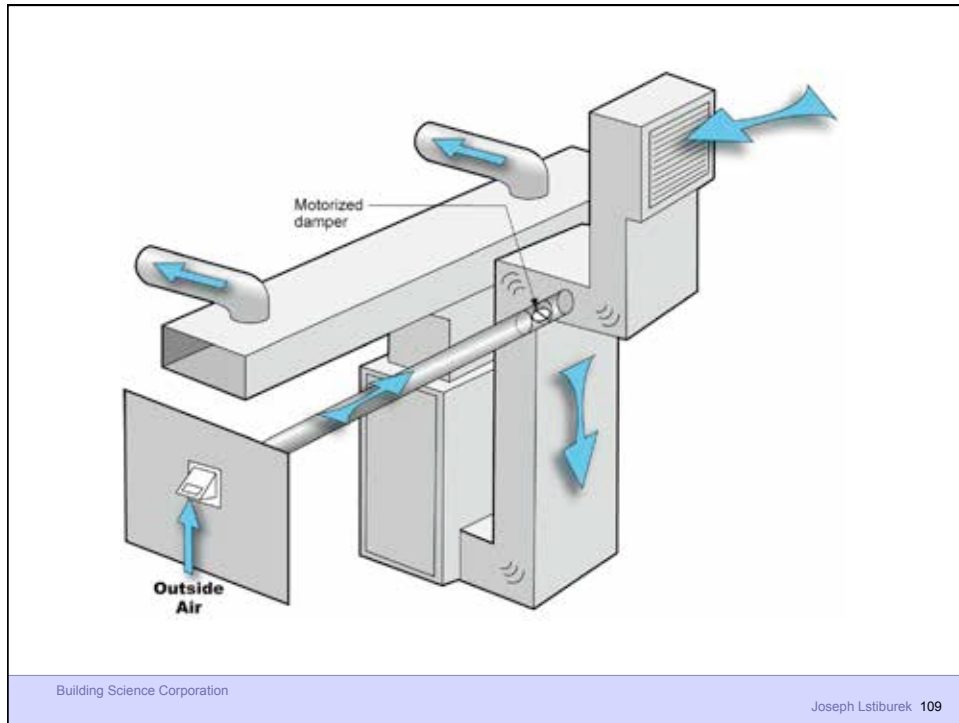

The Cult of The Blower Door

Building Science Corporation

Joseph Lstiburek 111



Building Science Corporation

Joseph Lstiburek 112

Blower Door Can't Get You The True ACH
On A Short Term Basis – Hour, Day, Week

Building Science Corporation

Joseph Lstiburek 113

Don't Know Where The Holes Are
Don't Know The Type of Holes
Don't Know The Pressure Across The Holes

Building Science Corporation

Joseph Lstiburek 114

Good For Long Term Average If No Big Pressures

Good For Long Term Average If No Big Pressures
Good For Average Annual Energy Prediction

Good For Long Term Average If No Big Pressures
Good For Average Annual Energy Prediction
Not Good For IAQ Unless You Accept Average Annual Exposure As A Metric

Cost of Addressing the Problems Are Less Than The Cost of Testing To See If You Have Problems

Combustion Safety
Indoor Contaminants
Comfort
Energy

Bring Combustion Appliances Up To Code
Control Pressures
Install Controlled Ventilation
Get Rid of Big Holes
Insulate

Code Compliant Combustion Air

Building Science Corporation

Joseph Lstiburek 121

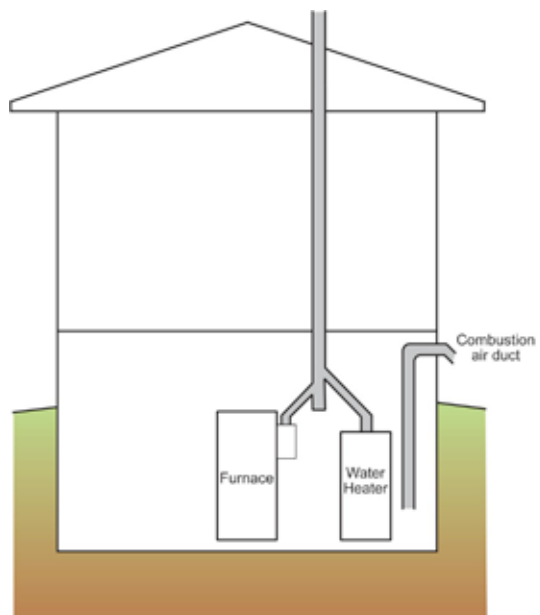

Building Science Corporation

Joseph Lstiburek 122

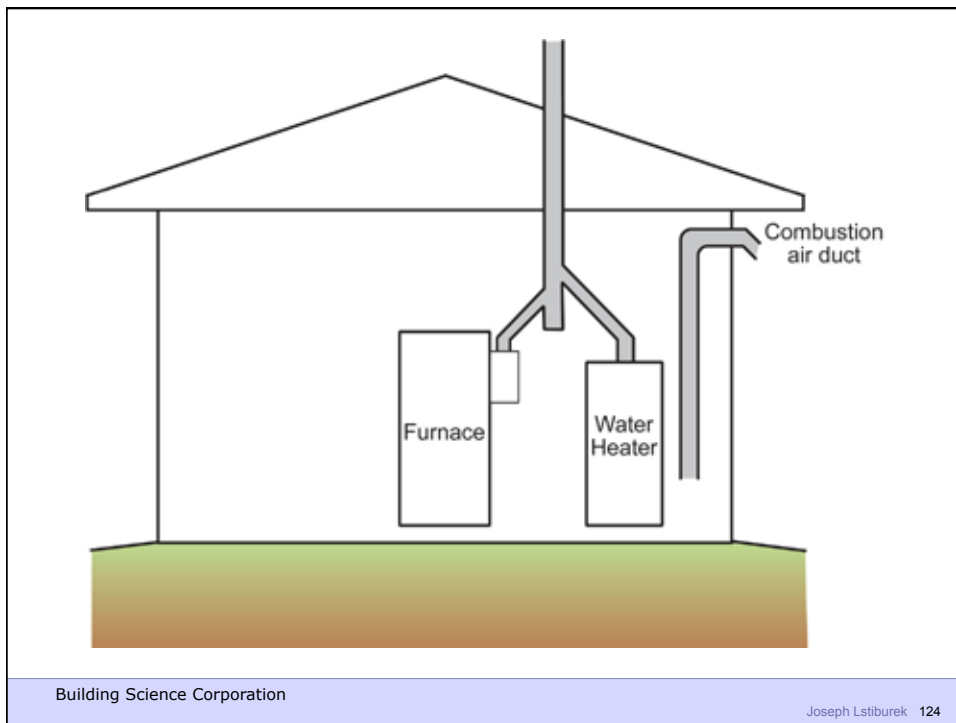
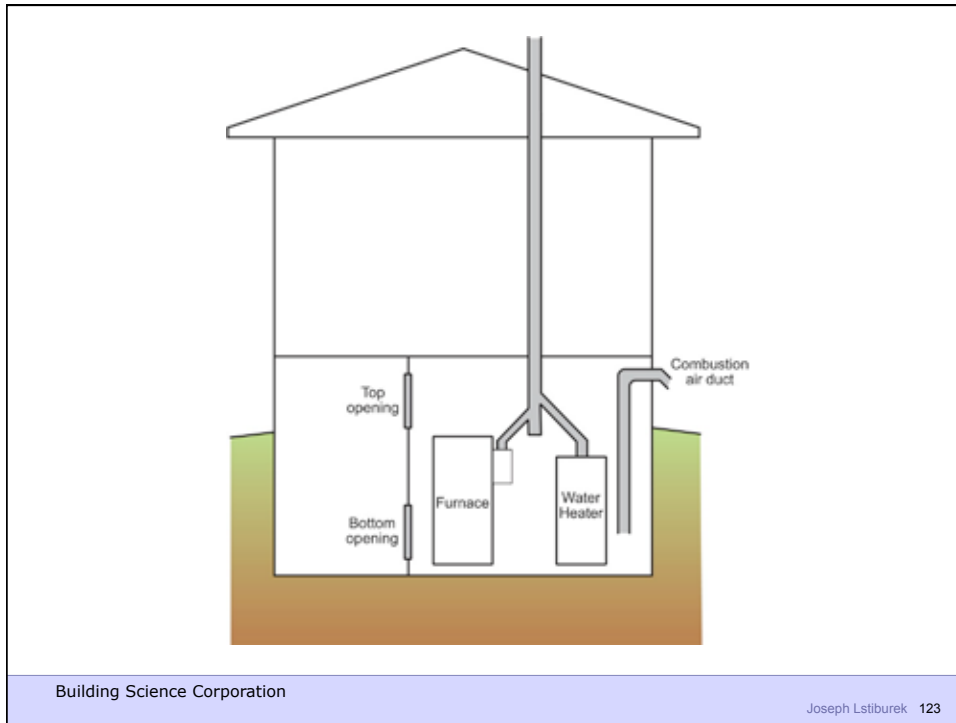

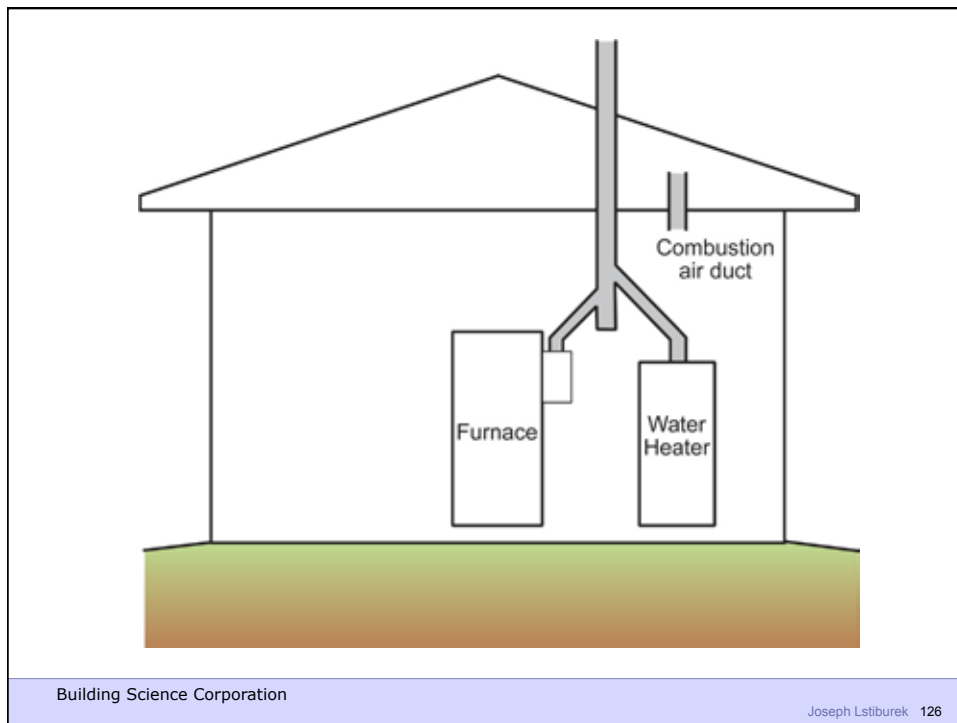
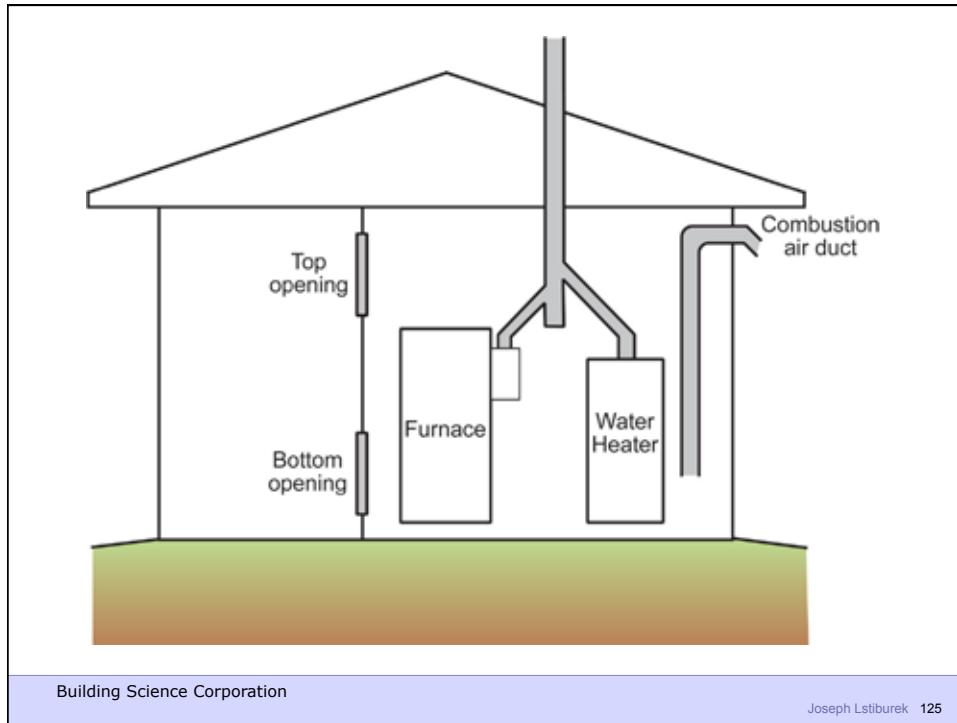

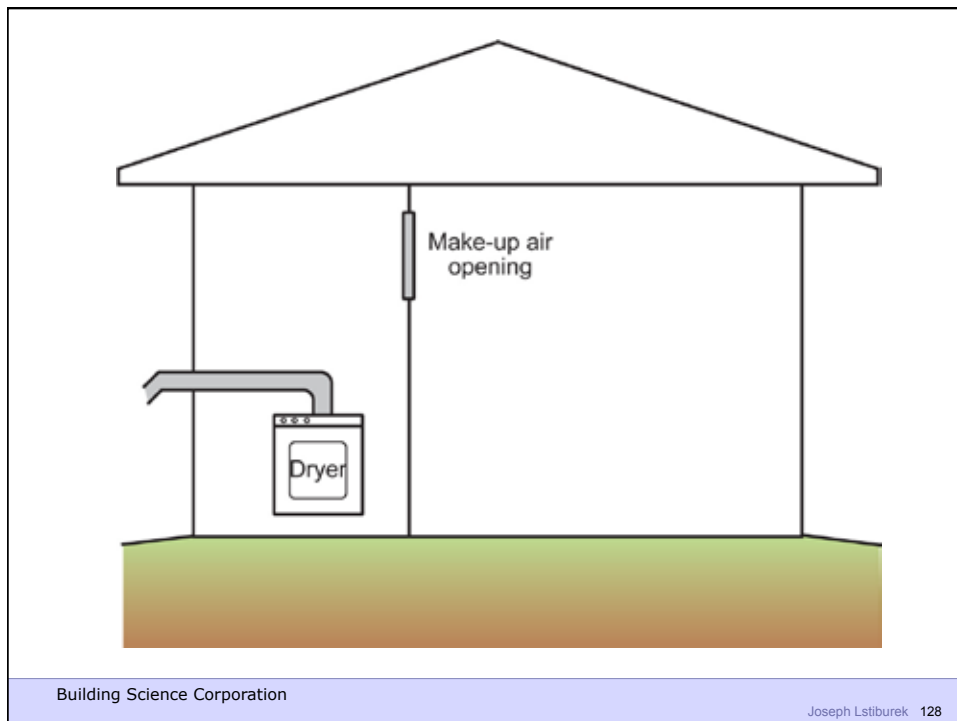
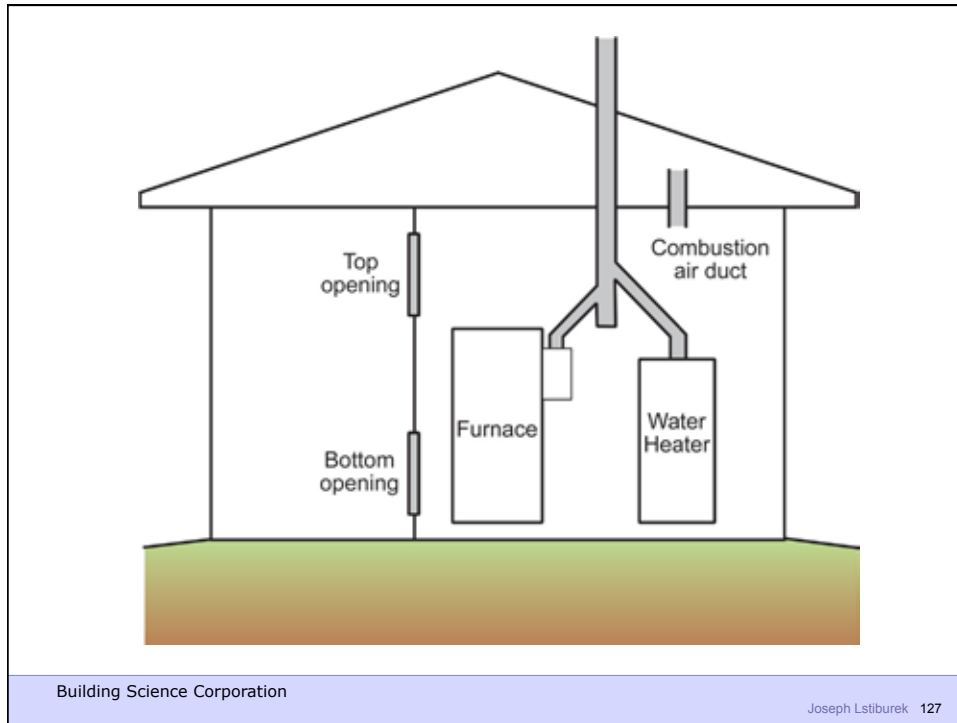

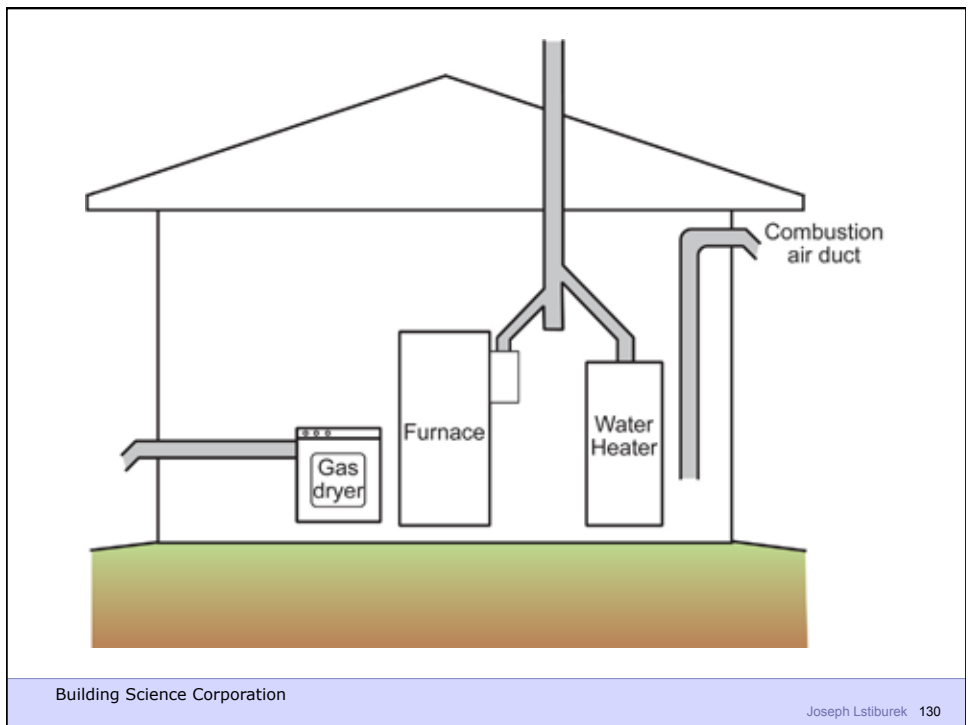
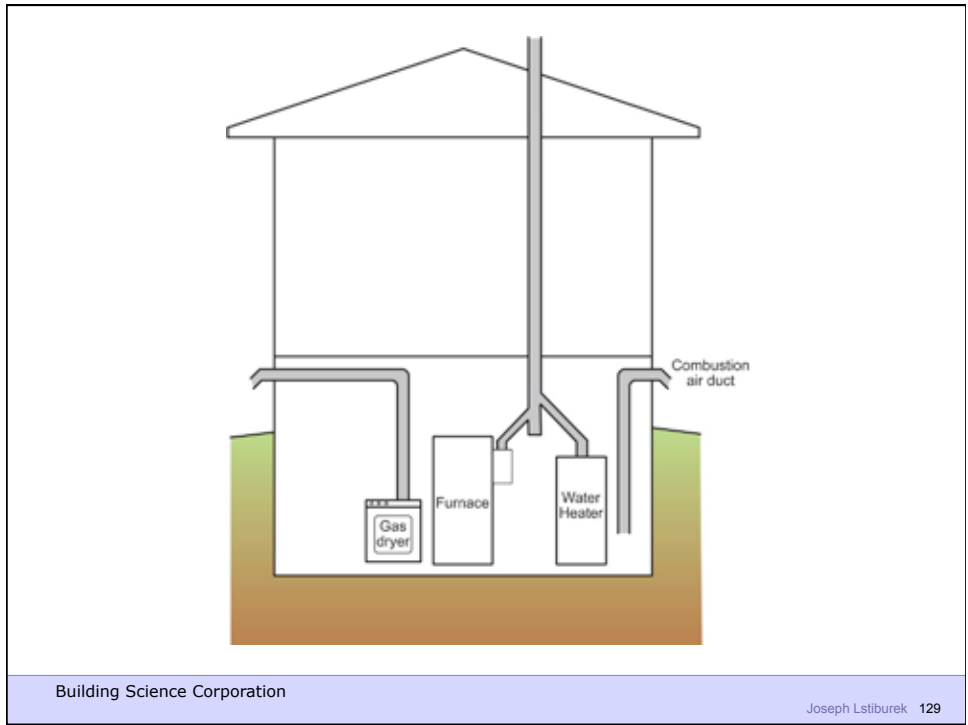

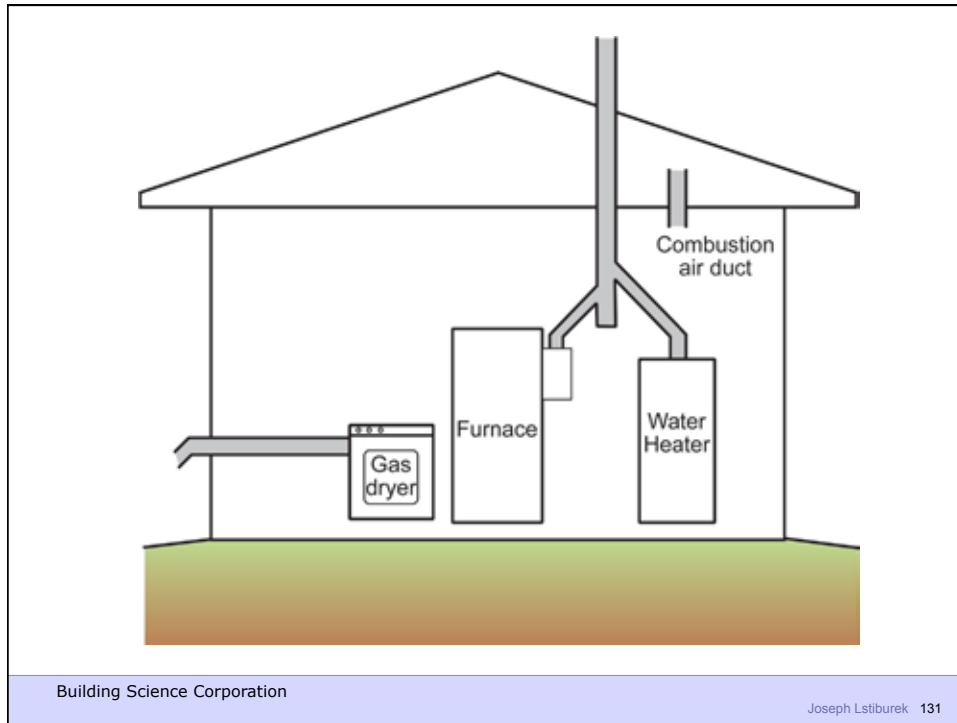

Sealed Combustion Appliances

Building Science Corporation

Joseph Lstiburek 132



Control Pressures

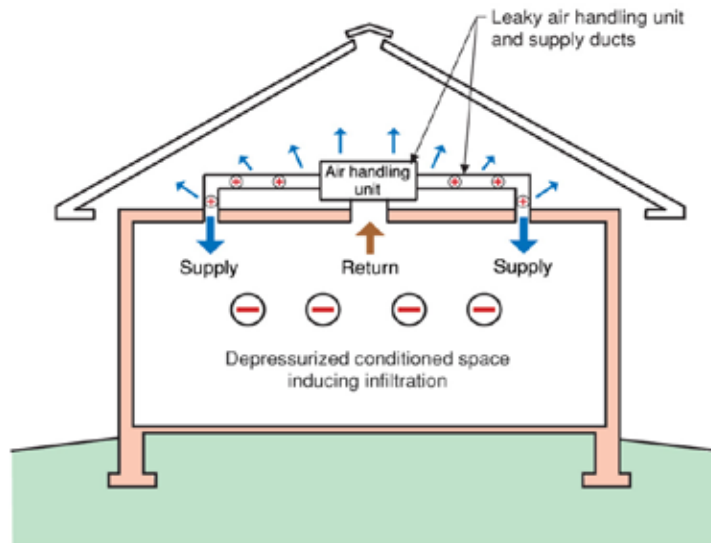

Note: Colored shading depicts the building's thermal barrier and pressure boundary. The thermal barrier and pressure boundary enclose the conditioned space.

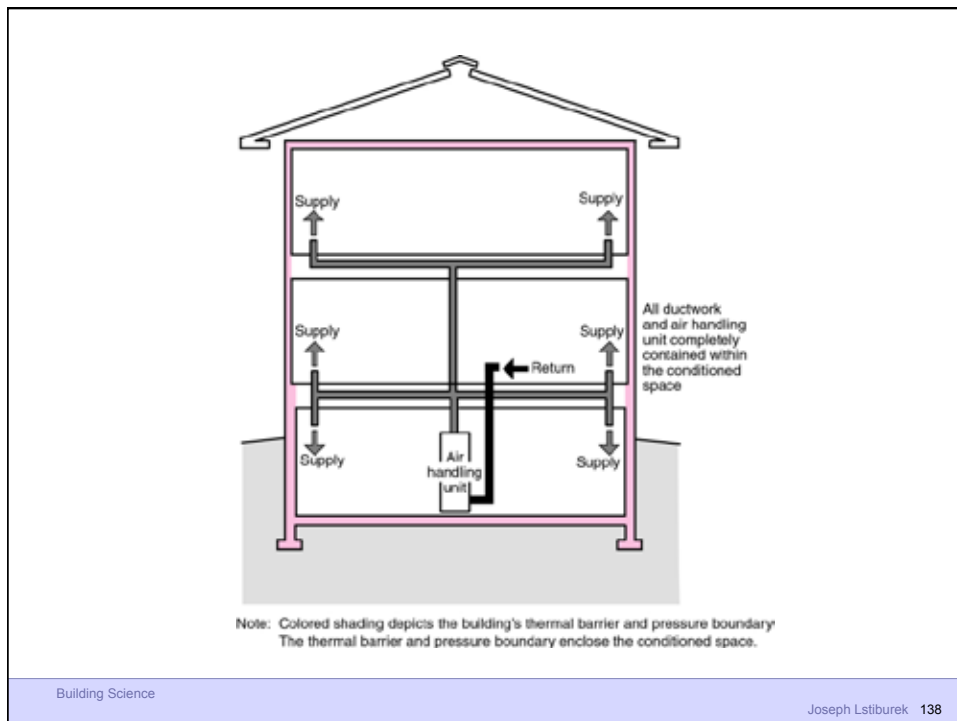
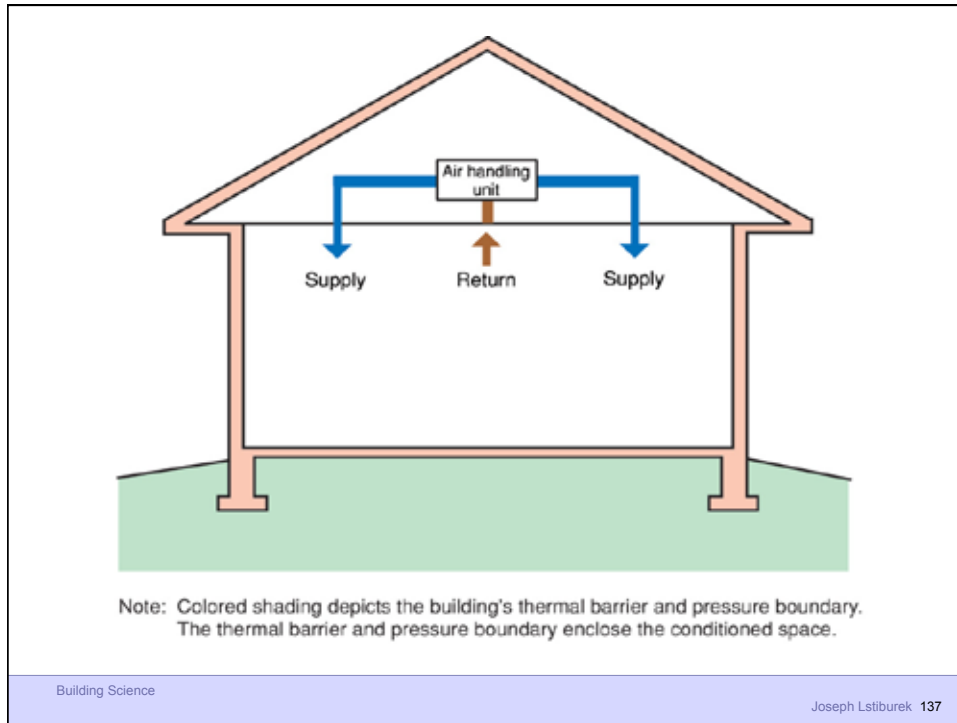

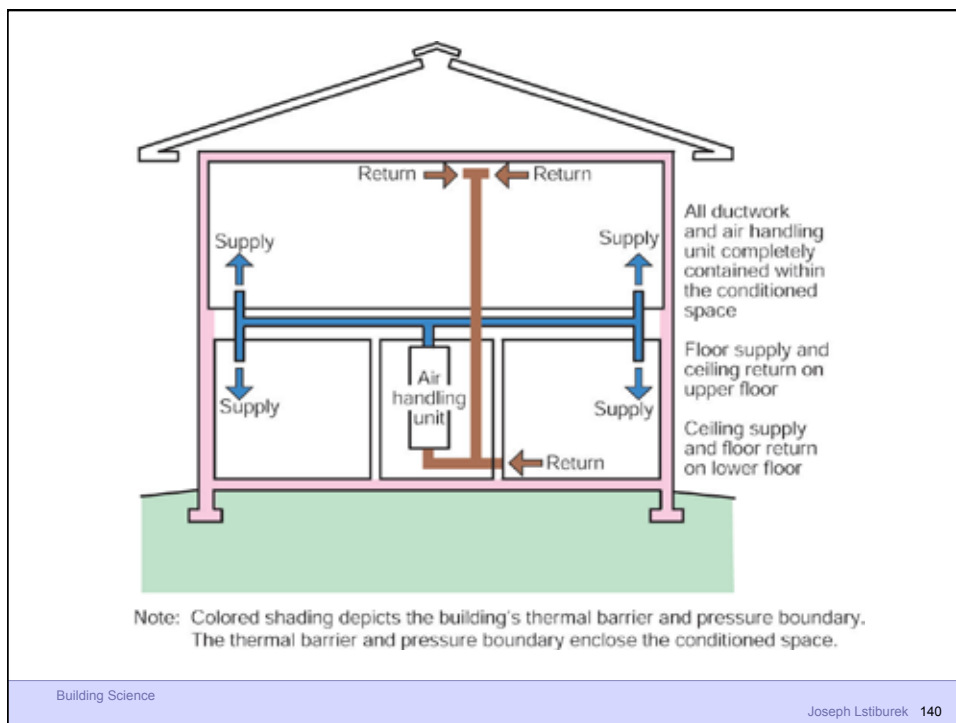
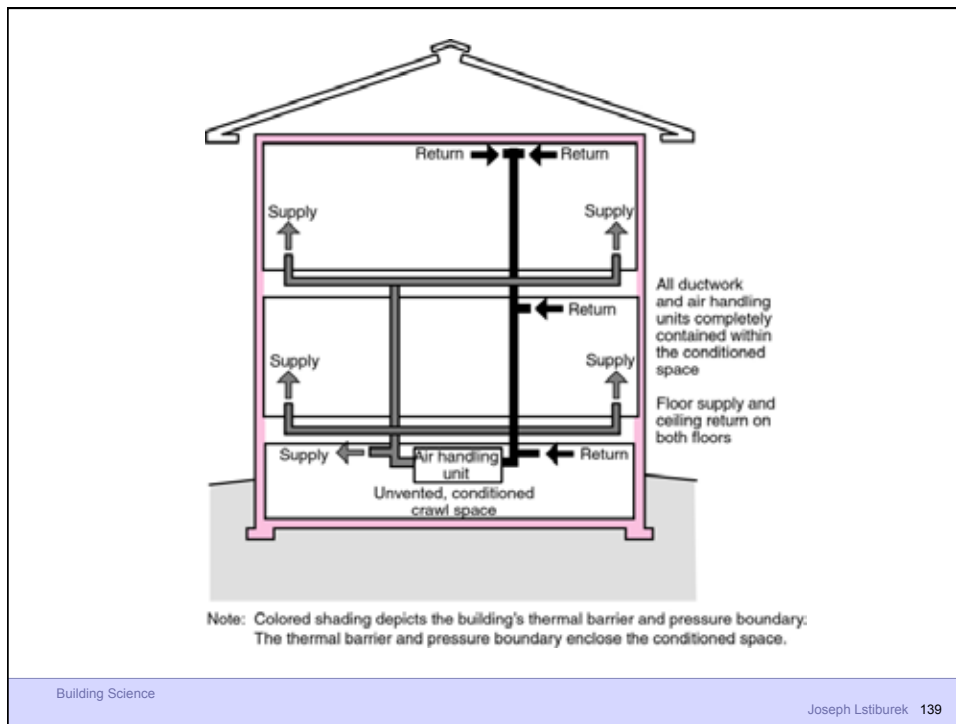

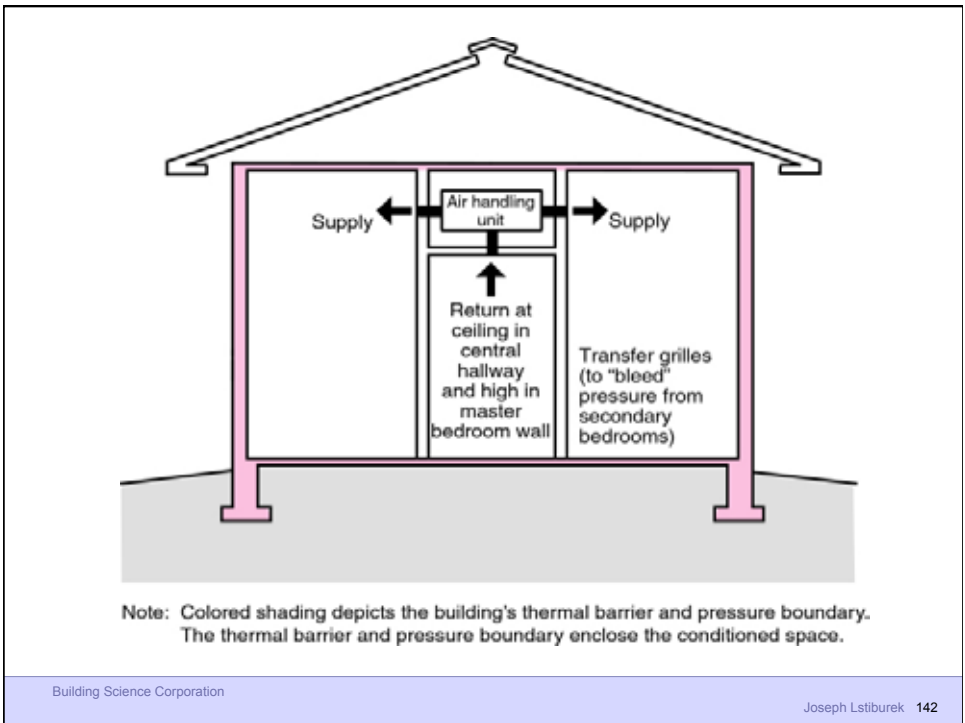

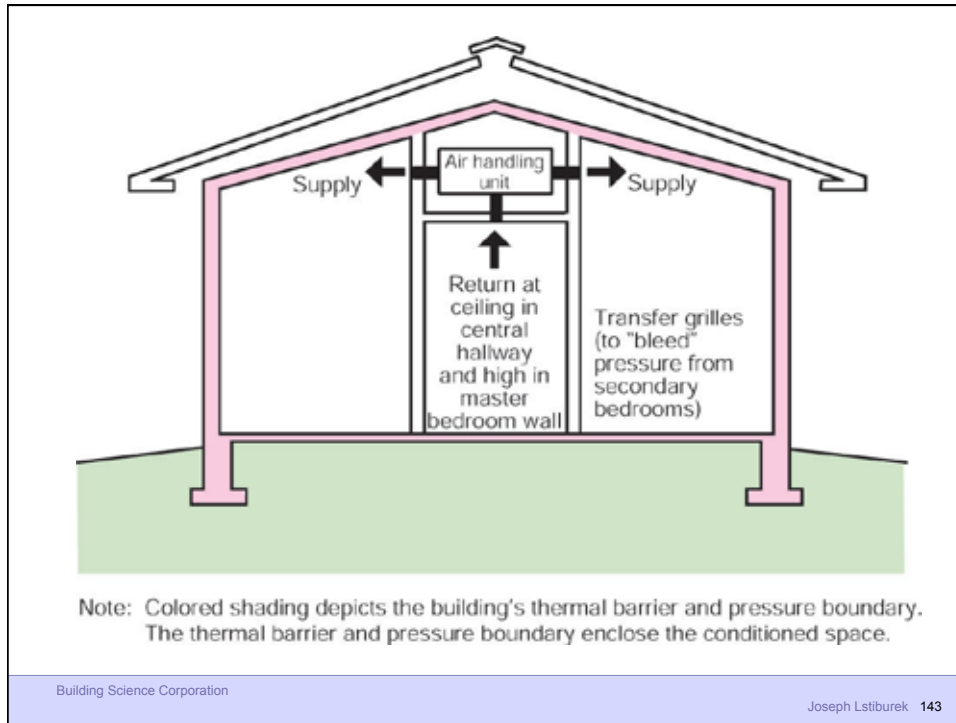

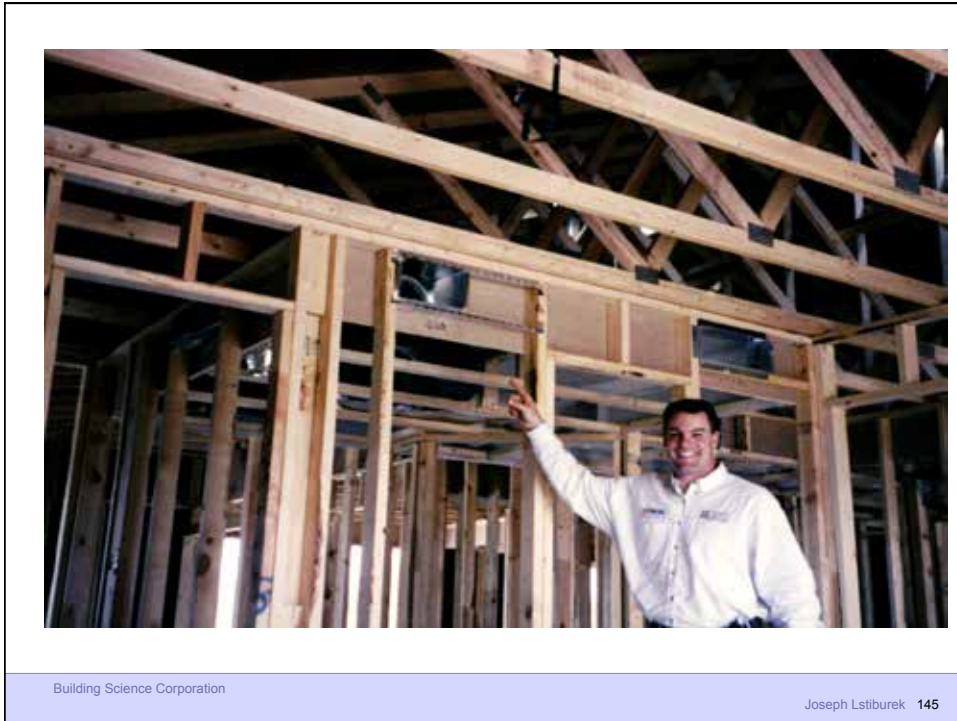

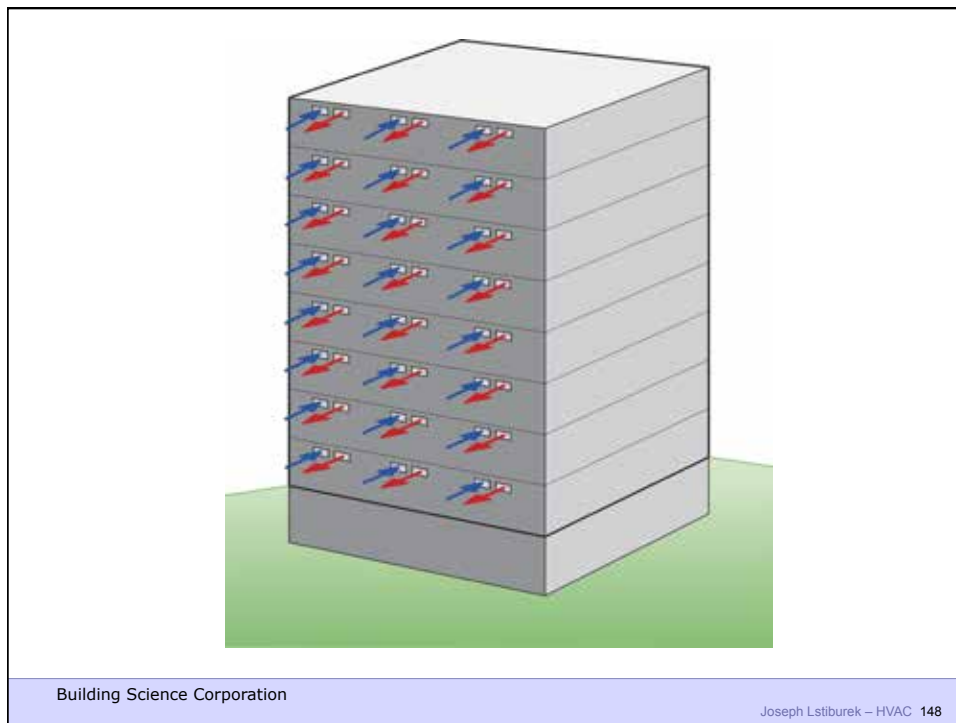
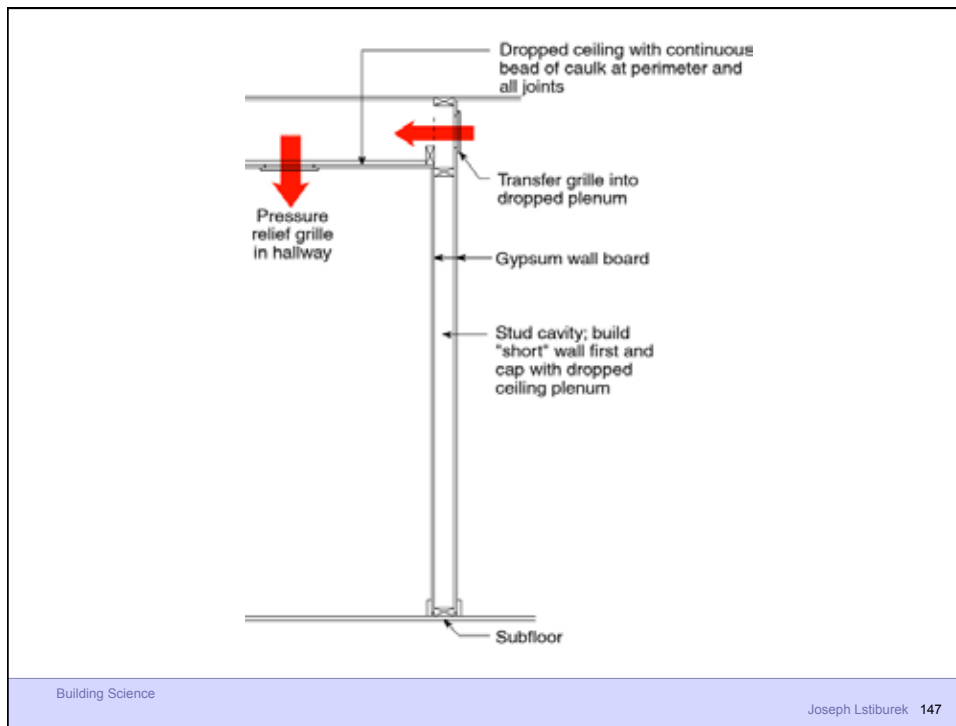



Building Science Corporation

Joseph Lstiburek 149

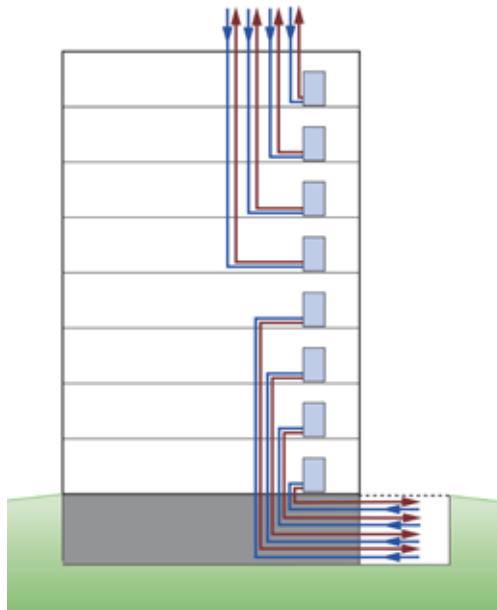

Building Science Corporation

Joseph Lstiburek – HVAC 150

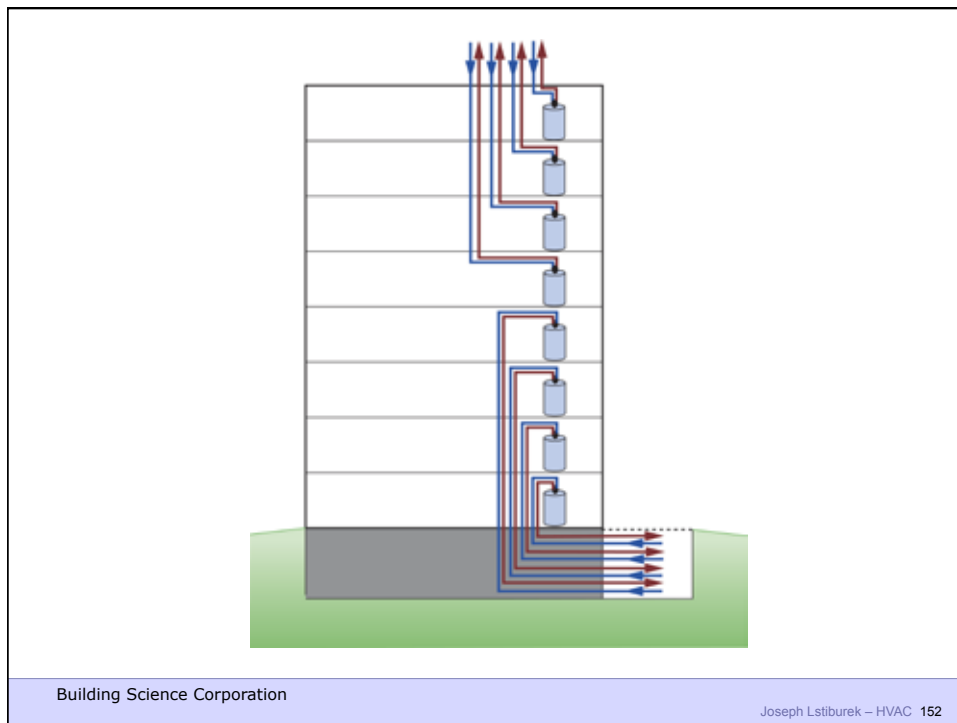
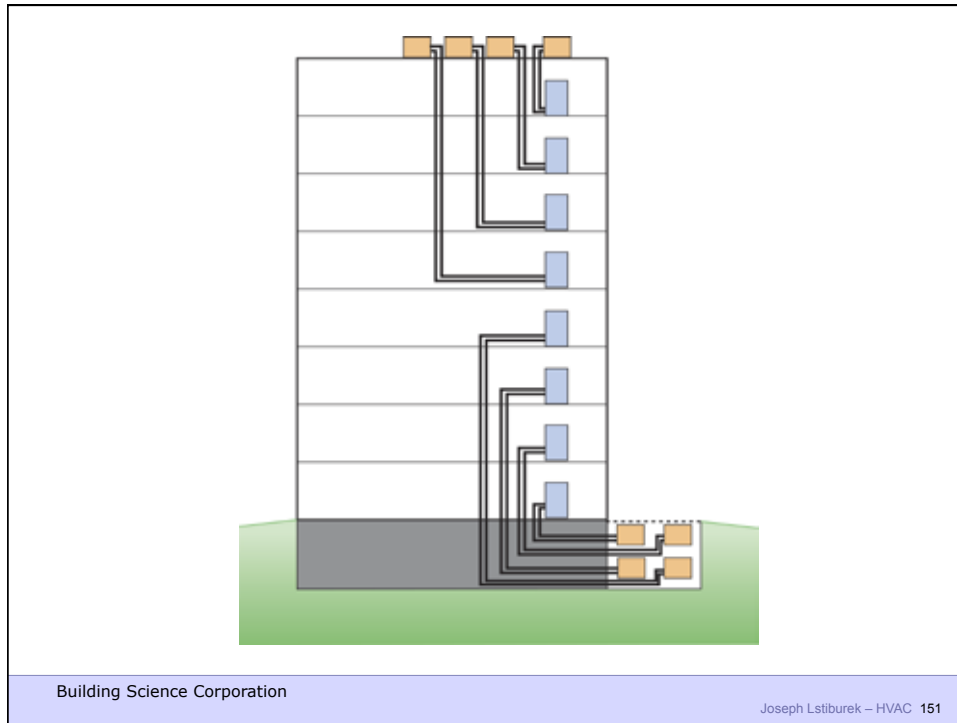

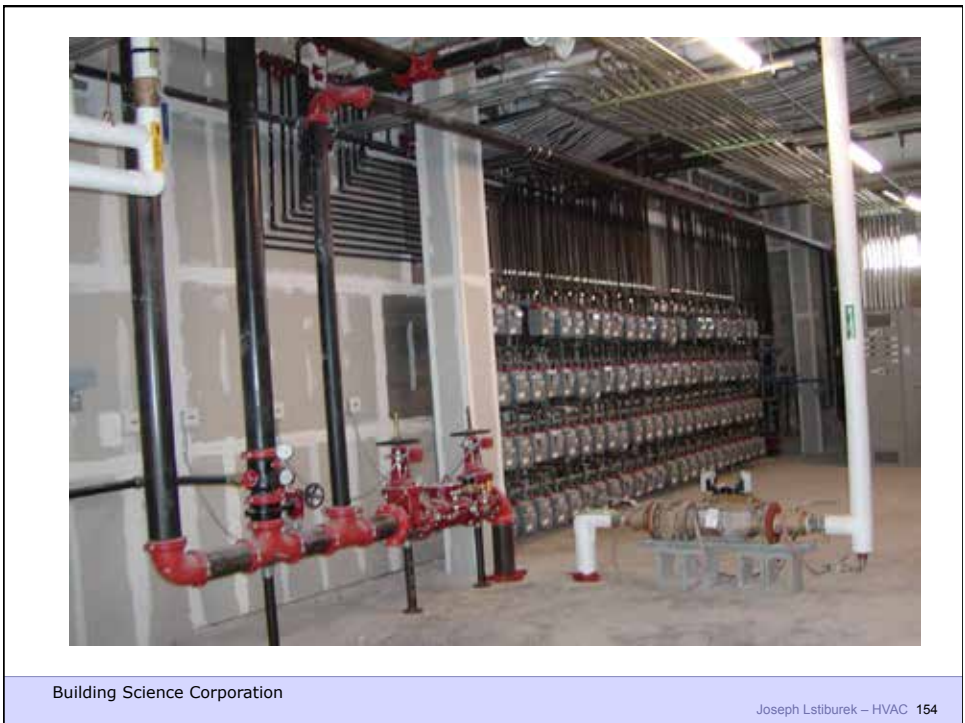







Building Science Corporation

Joseph Lstiburek 159



Building Science Corporation

Joseph Lstiburek – HVAC 160



Building Science Corporation

Joseph Lstiburek – HVAC 161



Building Science Corporation

Joseph Lstiburek – HVAC 162

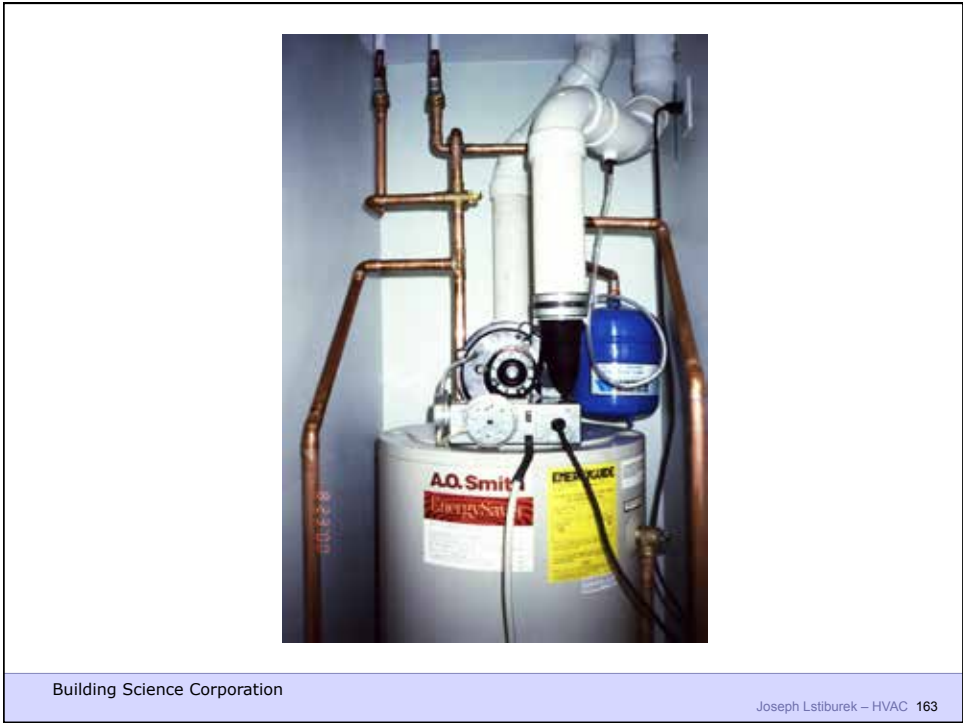

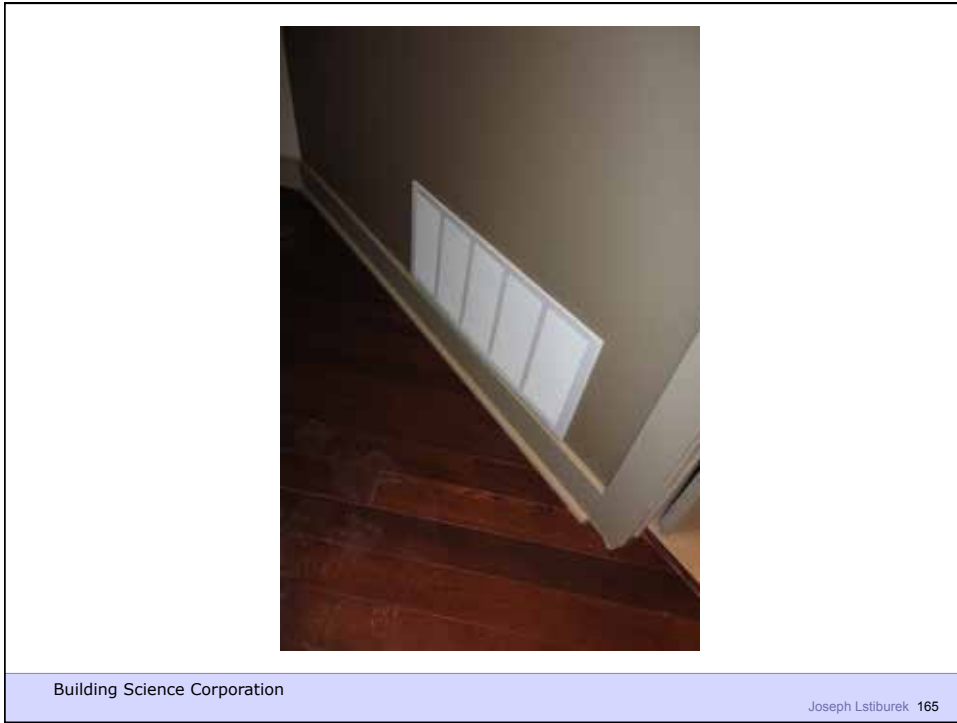

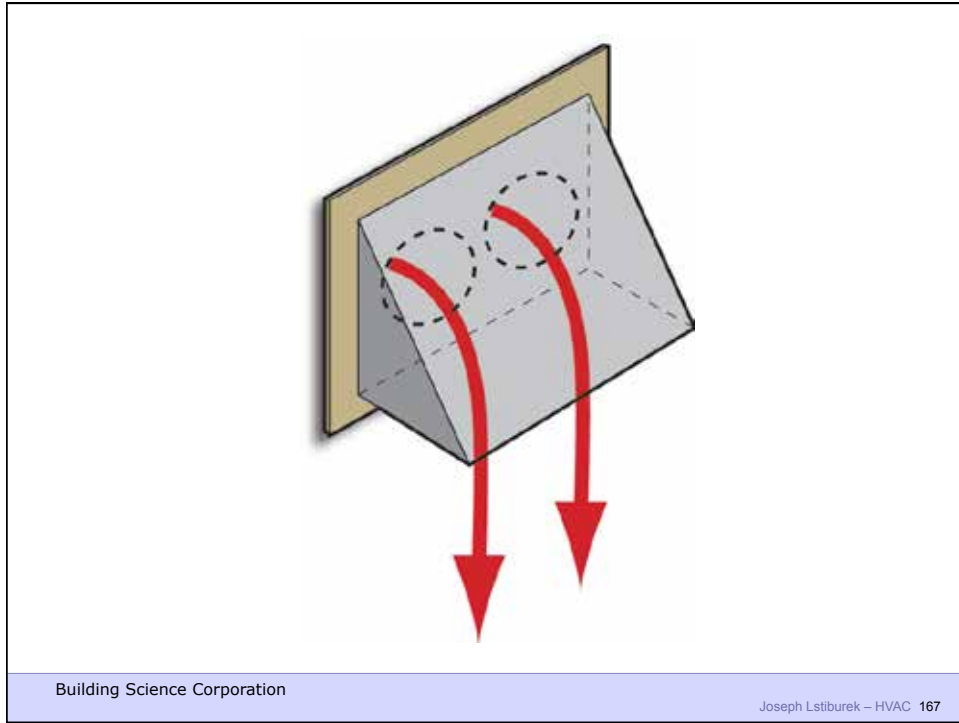





Building Science Corporation

Joseph Lstiburek 171



Building Science Corporation

Joseph Lstiburek 172

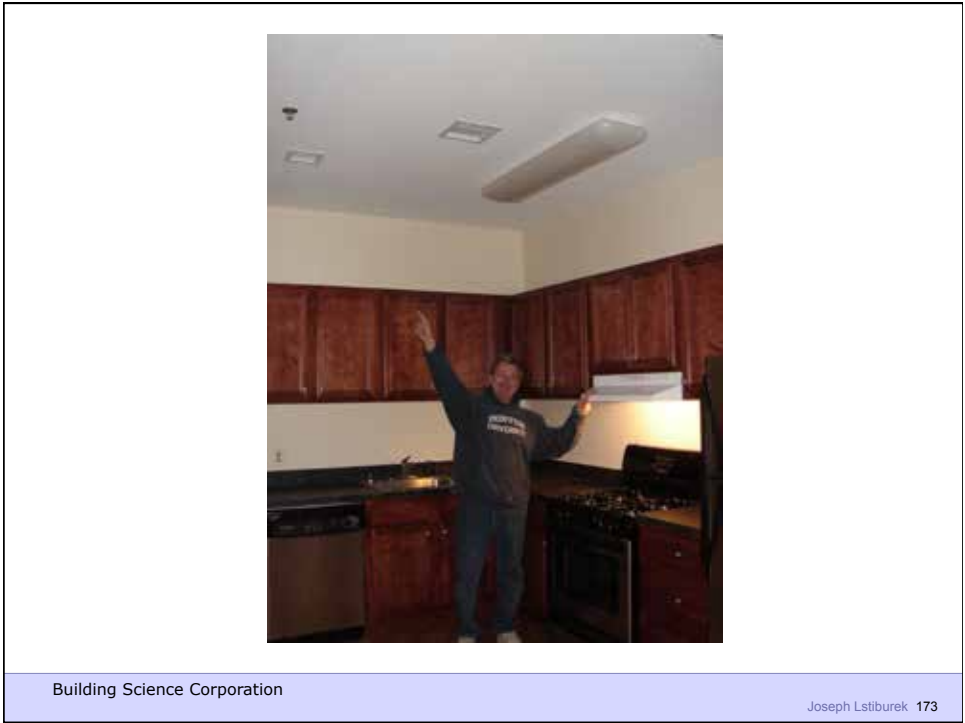

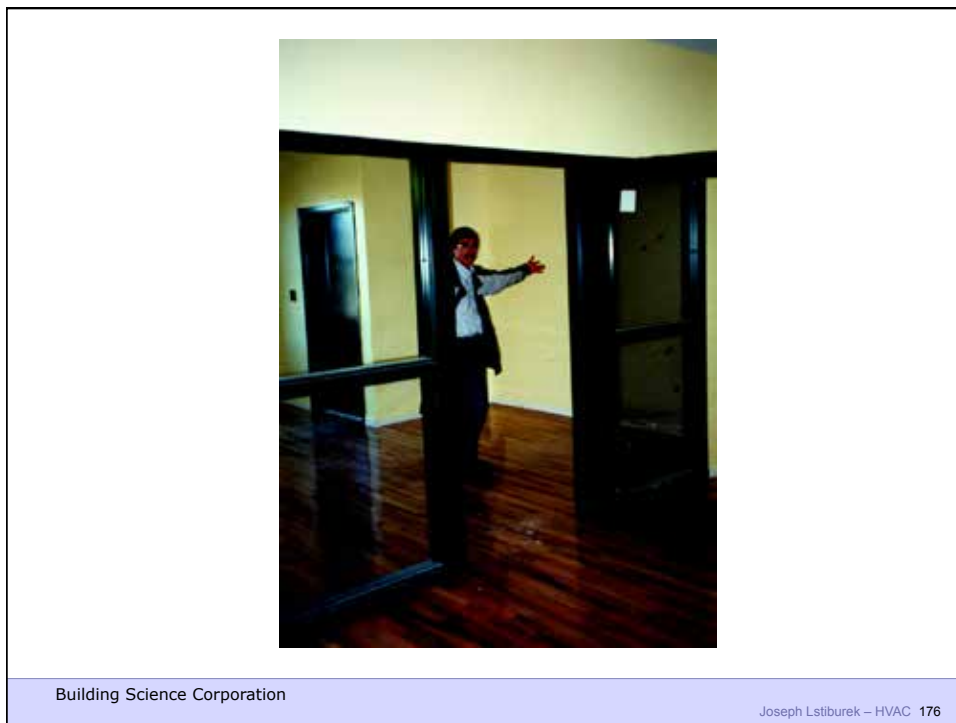
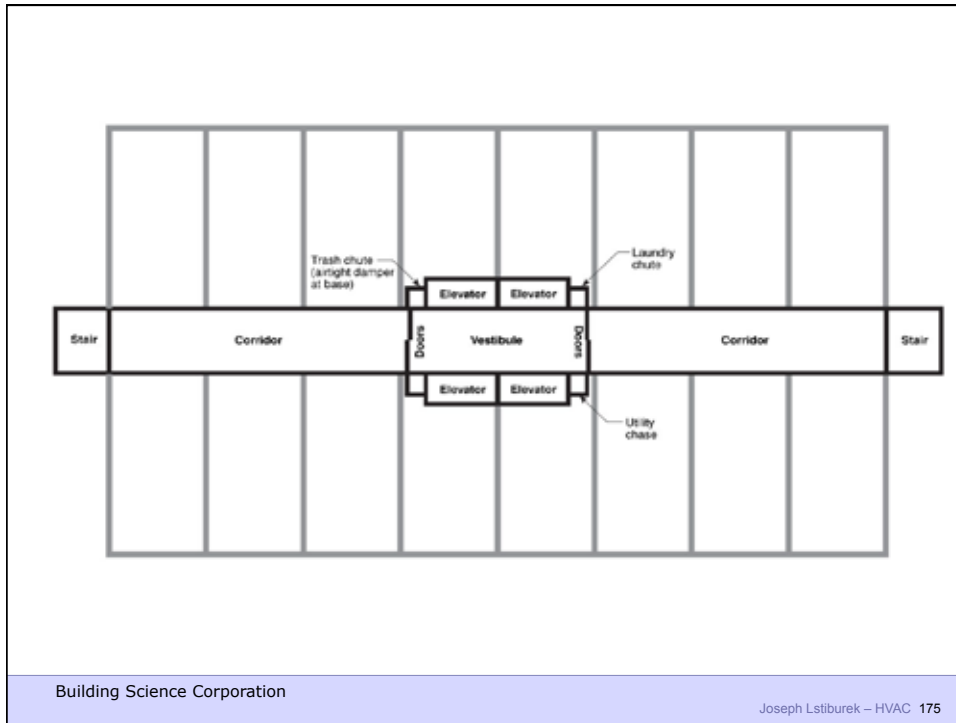

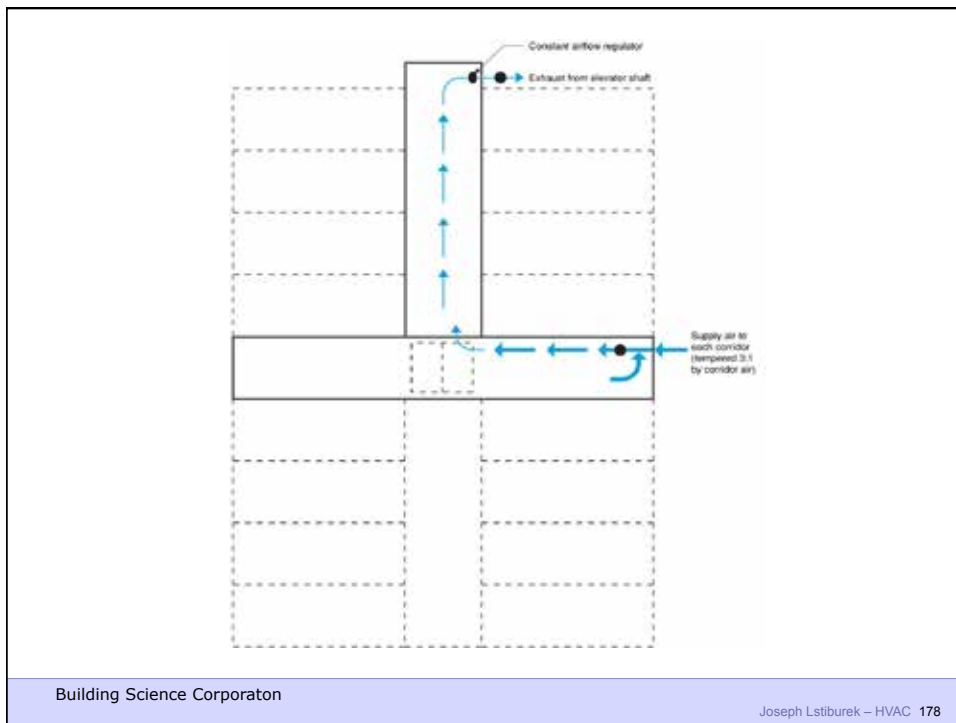
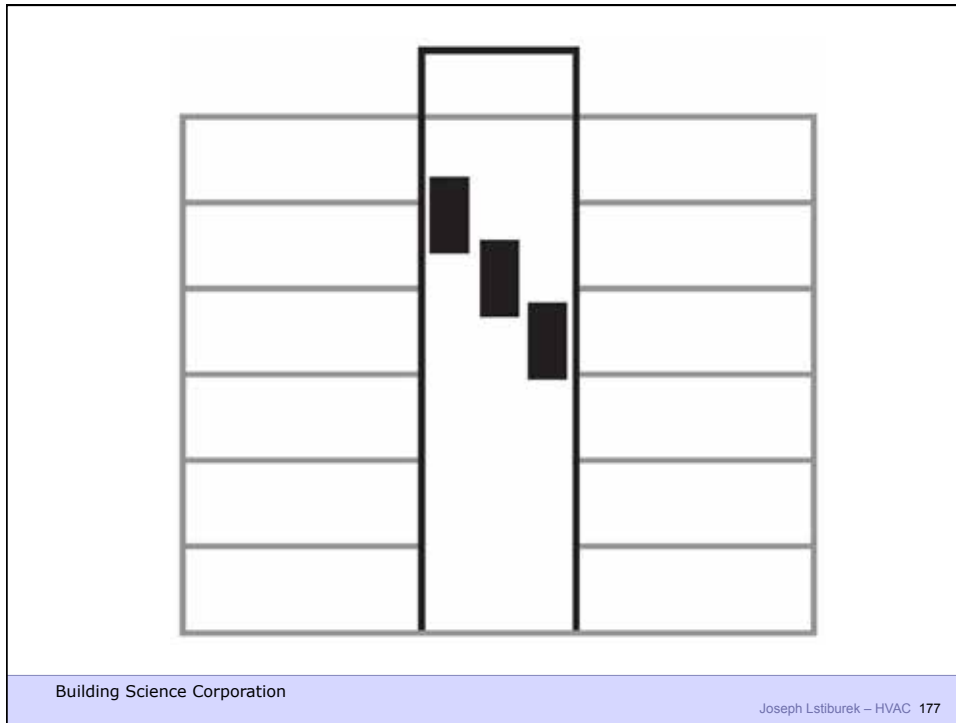

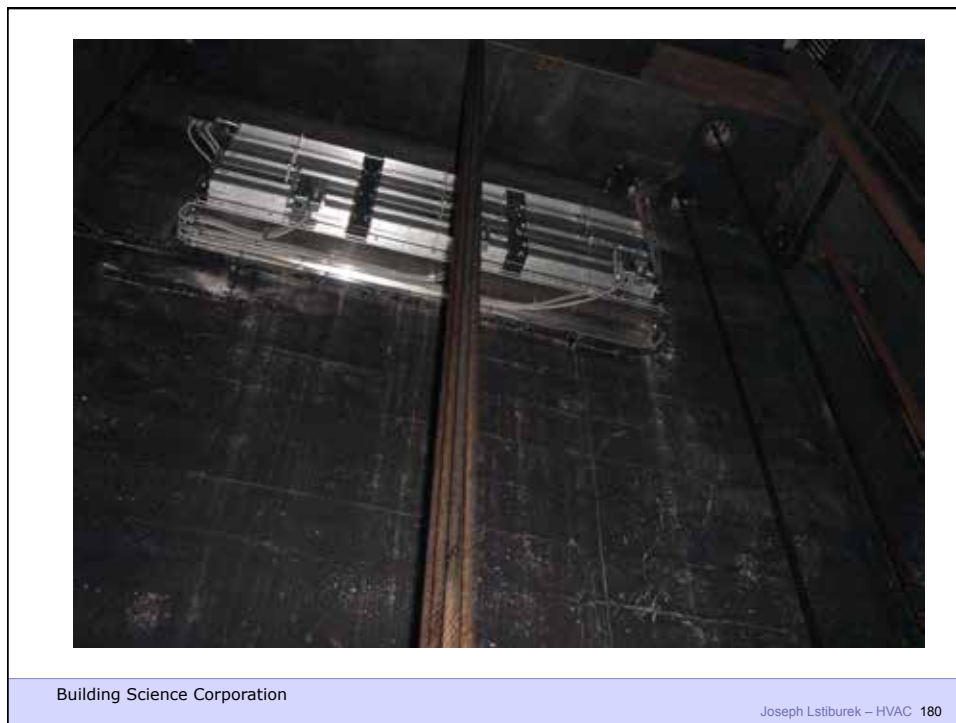
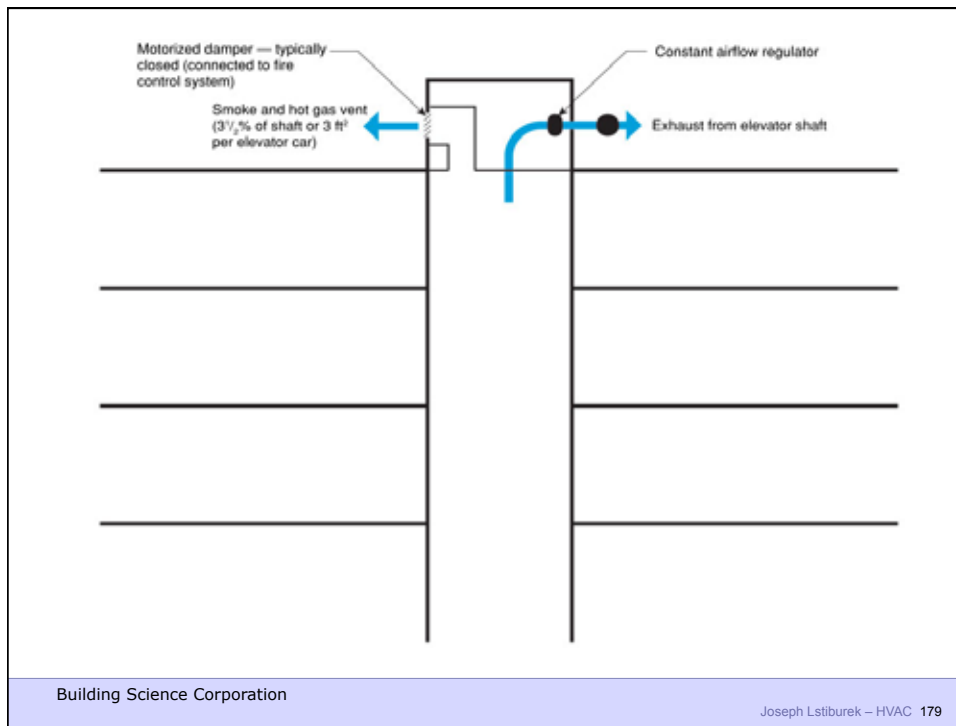

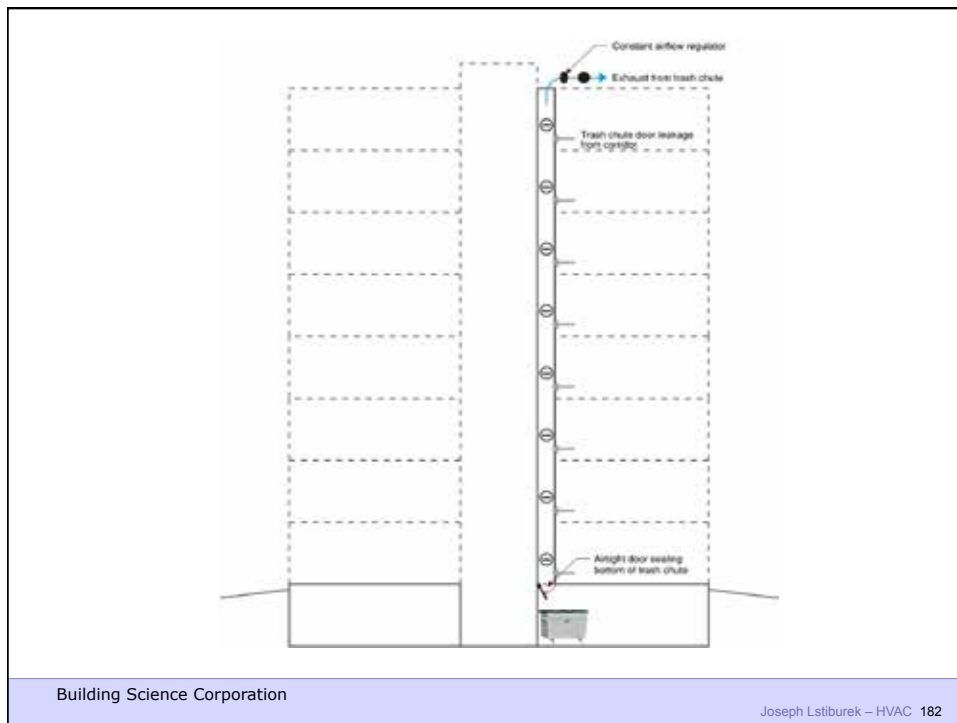
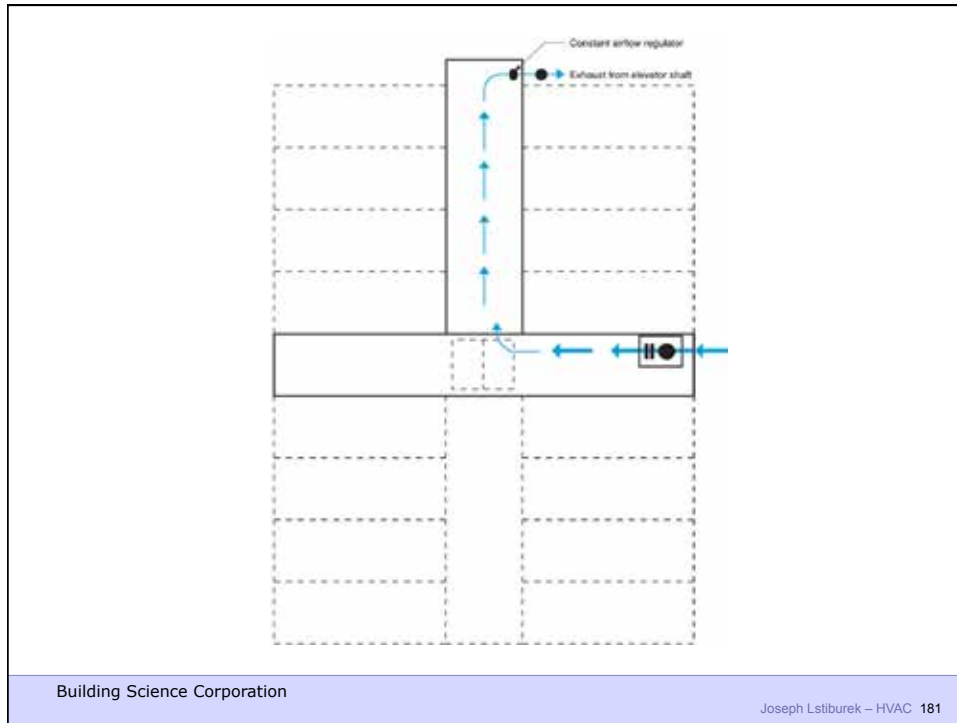

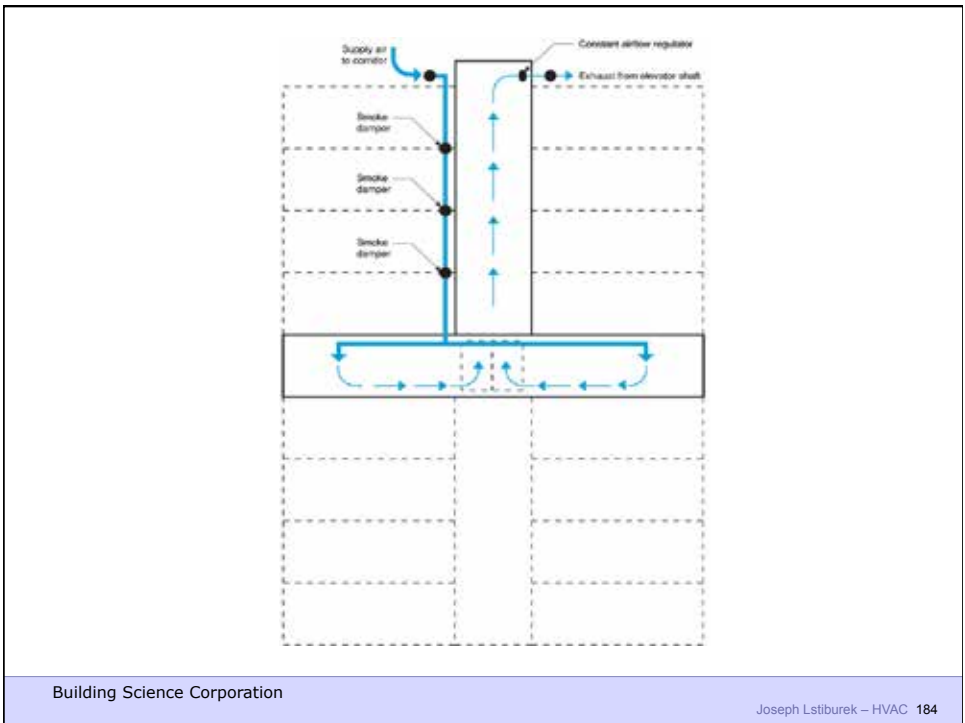

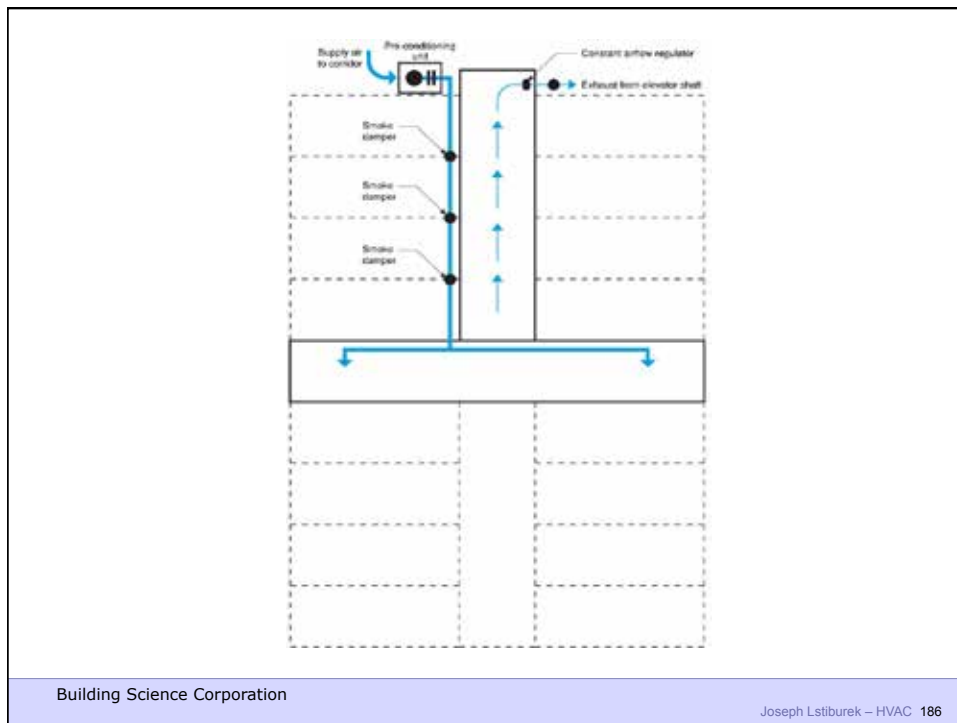
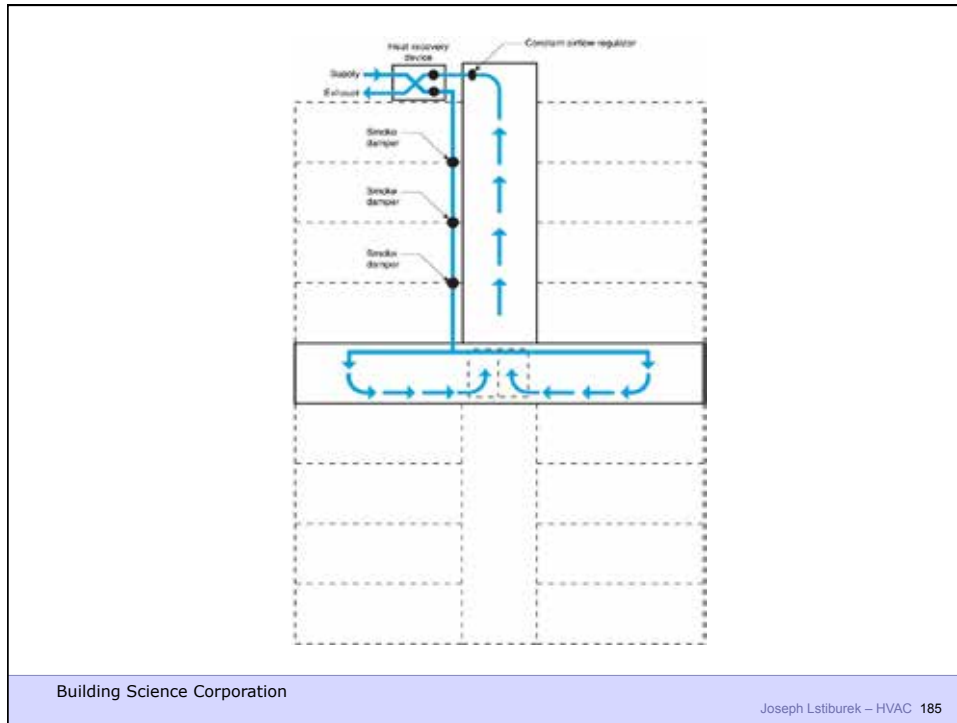

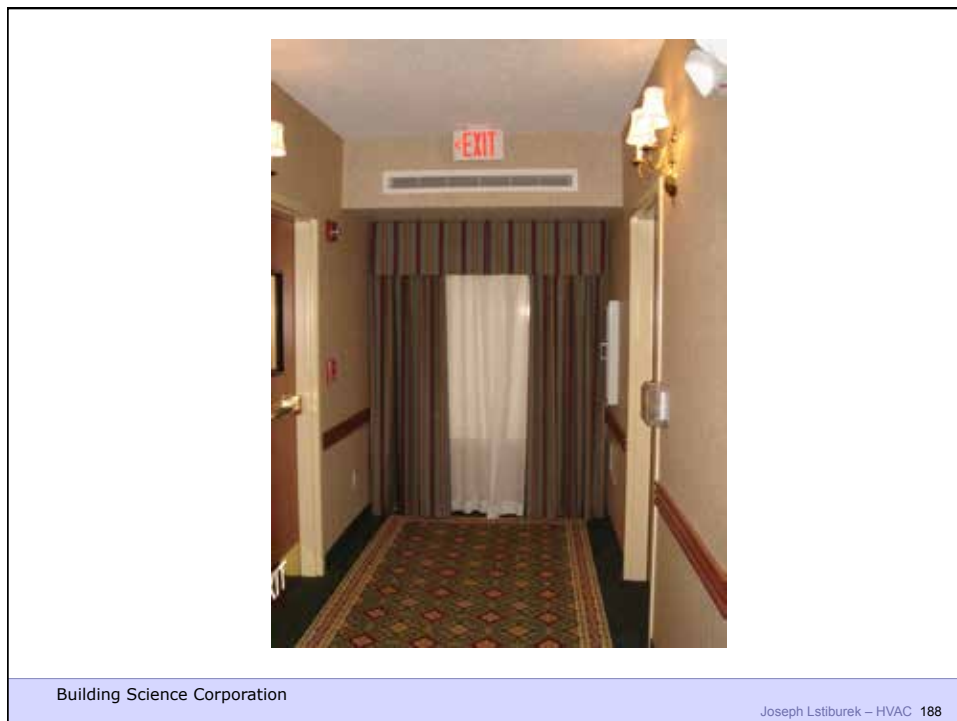
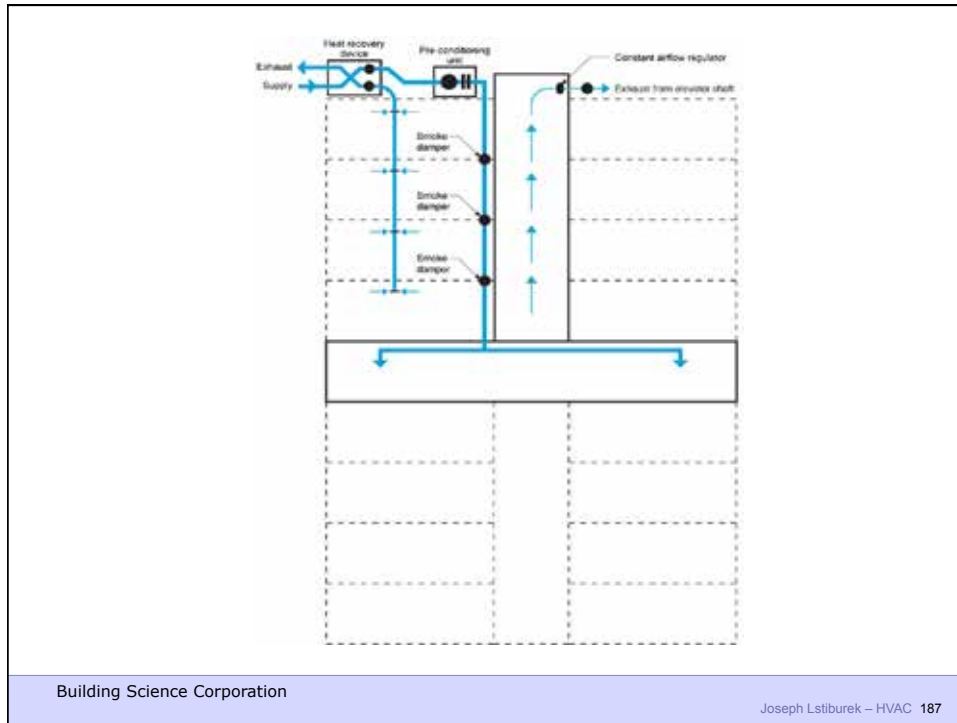

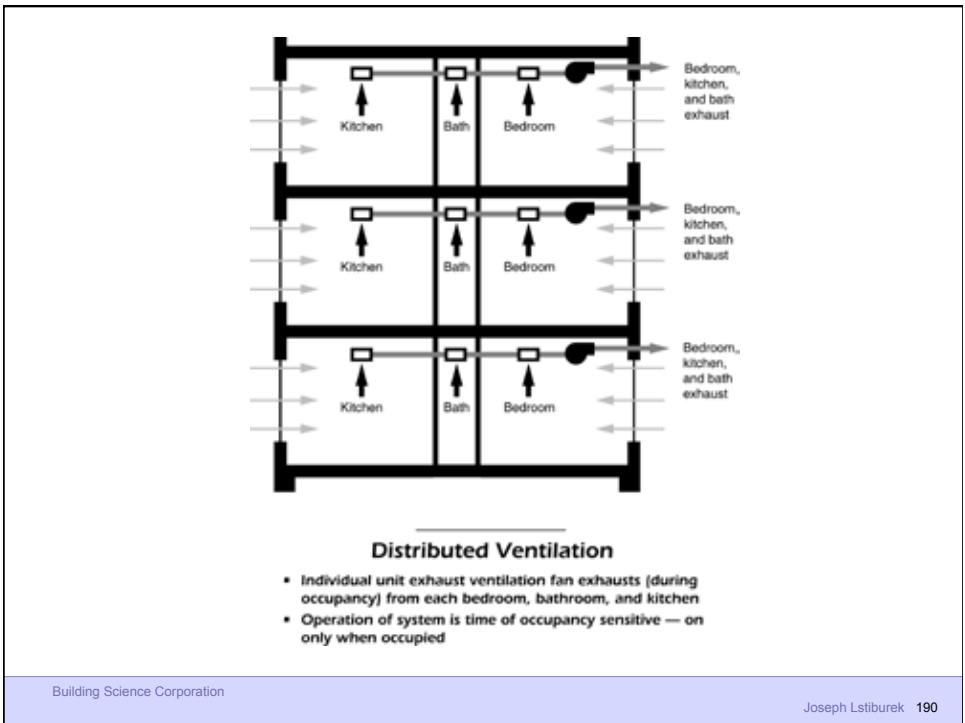
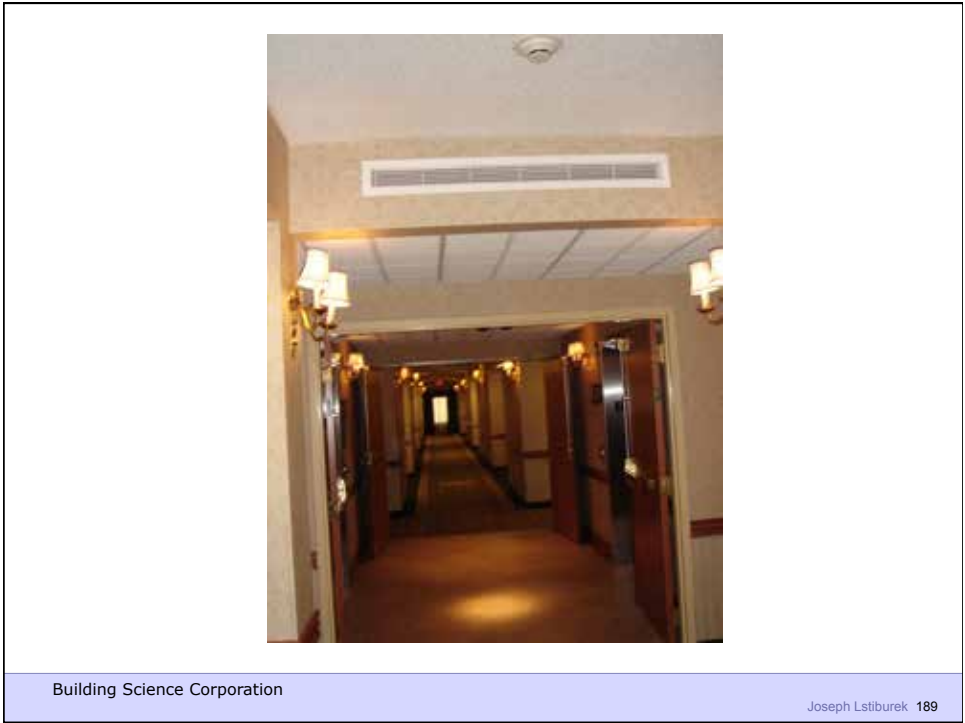



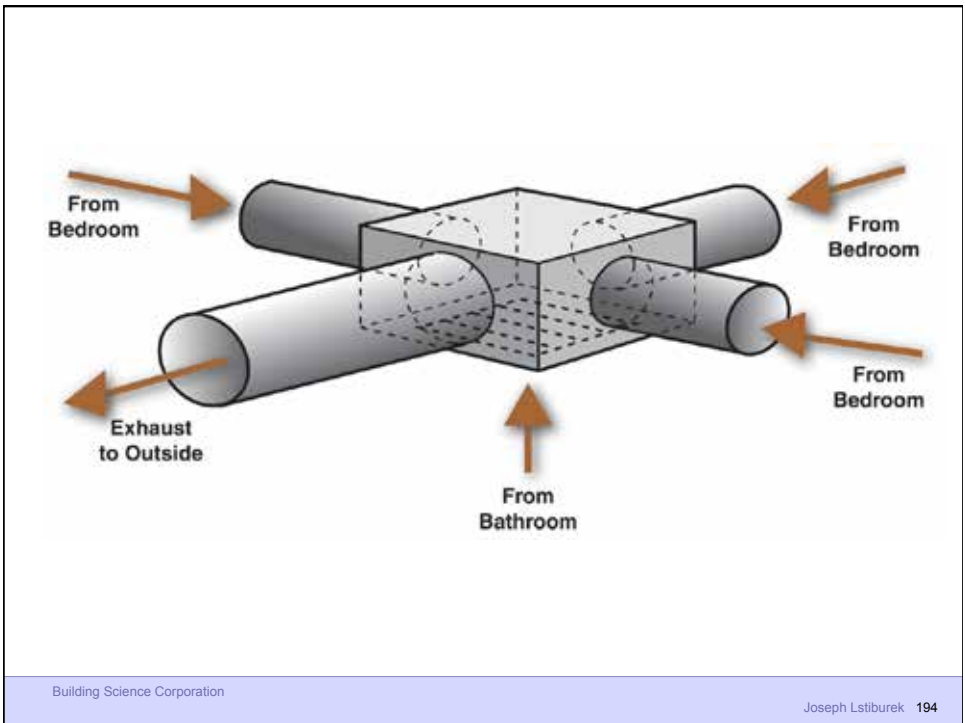

Ventilation Rates Are Based on Odor Control

Ventilation Rates Are Based on Odor Control Health Science Basis for Ventilation Rates is Extremely Limited

Ventilation Rates Are Based on Odor Control
Health Science Basis for Ventilation Rates is
Extremely Limited
Almost Nothing Cited Applies to Housing

Ventilation Rates Are Based on Odor Control
Health Science Basis for Ventilation Rates is
Extremely Limited
Almost Nothing Cited Applies to Housing
The Applicable Studies Focus on Dampness

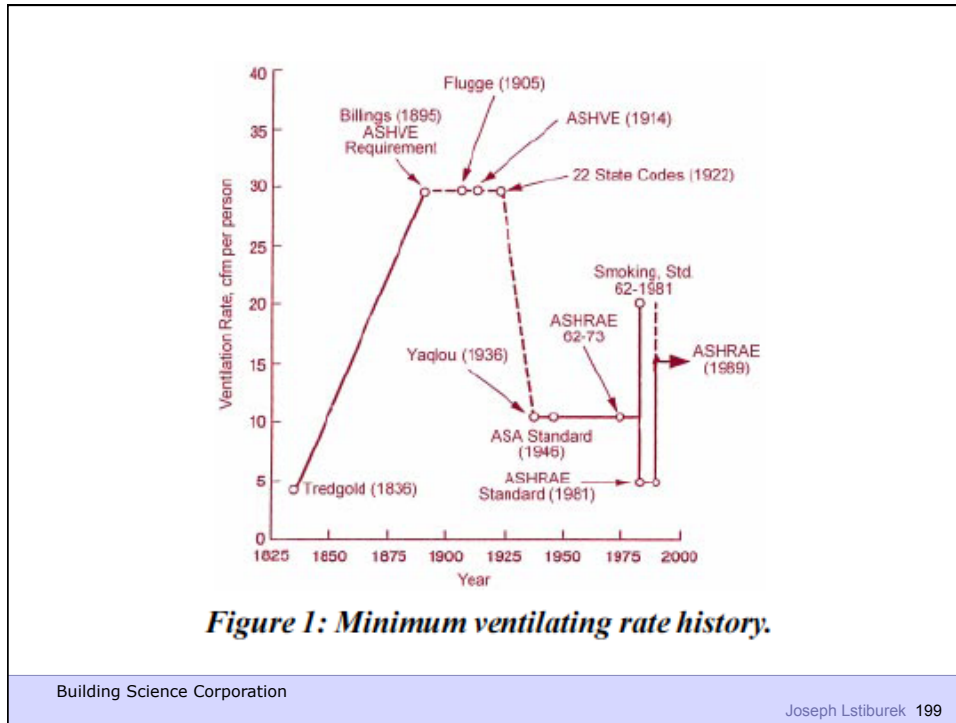

House

2,000 ft²
3 bedrooms
8 ft. ceiling
Volume: 16,000 ft³

- .35 ach 93 cfm
- .30 ach 80 cfm
- .25 ach 67 cfm
- .20 ach 53 cfm
- .15 ach 40 cfm

House

2,000 ft²
3 bedrooms
8 ft. ceiling
Volume: 16,000 ft³

Ventilation Rates

.35 ach	93 cfm	62 - 73	5 cfm/person	20 cfm
.30 ach	80 cfm		10 cfm/person	40 cfm
.25 ach	67 cfm	62 - 89	15 cfm/person	60 cfm
.20 ach	53 cfm		.35 ach	90 cfm
.15 ach	40 cfm	62.2 - 2010	7.5 cfm/person	50 cfm
			+ 0.01	
		62.2 - 2013	7.5 cfm/person	90 cfm
			+ 0.03	

Office

Occupant Density

15/1000 ft² (67 ft²/person) 62 - 89
 15 cfm/person

5/1000 ft² (200 ft²/person) 62.1 - 2007
 17 cfm/person

Correctional Facility Cell

Occupant Density

20/1000 ft² (48 ft²/person) 62.1 – 2007
 10 cfm/person

C.P. Yaglou

Harvard School of Public Health

1936

1955

150 ft³ → 20 cfm/person300 ft³ → 12 cfm/person**C.P. Yaglou**

Harvard School of Public Health

1936

1955

150 ft³ → 20 cfm/person 18.75 ft² 106 occupants300 ft³ → 12 cfm/person 37.5 ft² 53 occupants**Experiment**470 ft³ → 59 ft²200 ft³ → 25 ft²100 ft³ → 12 ft²

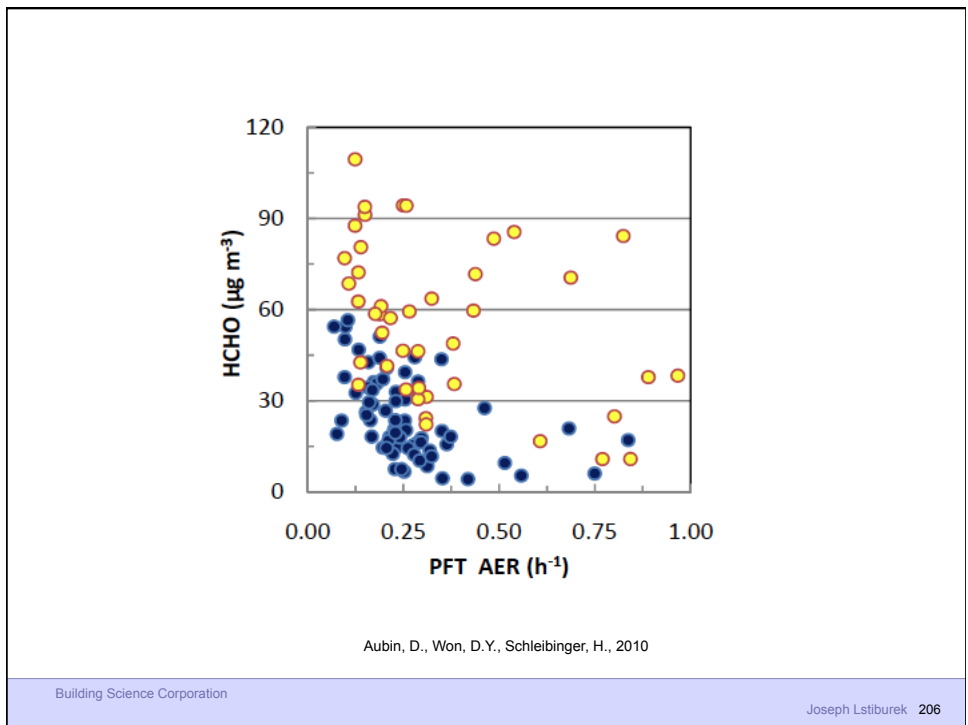
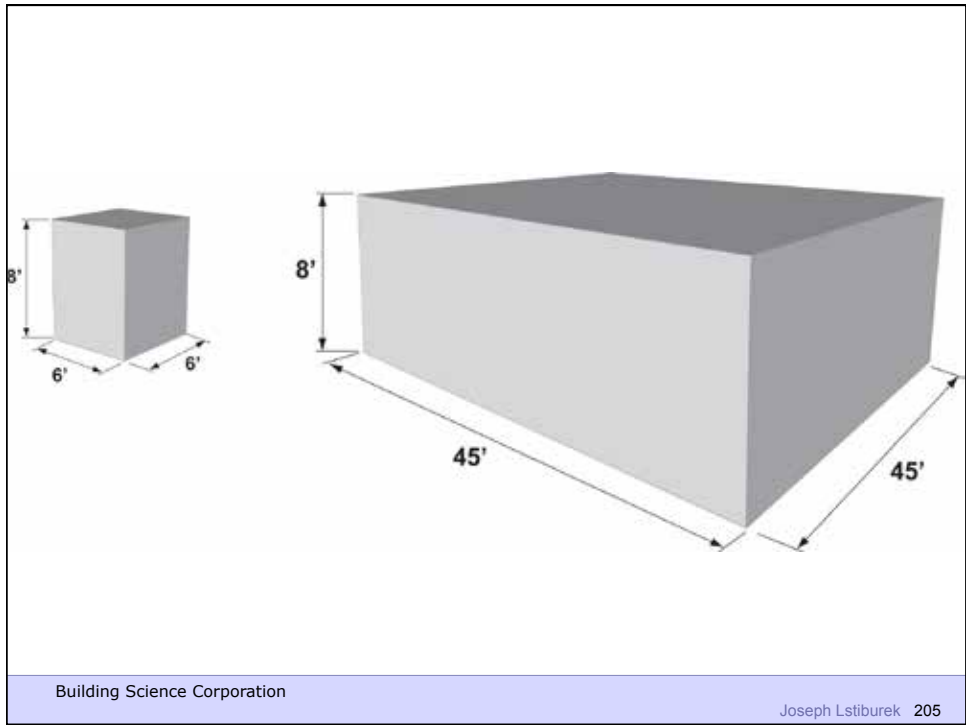

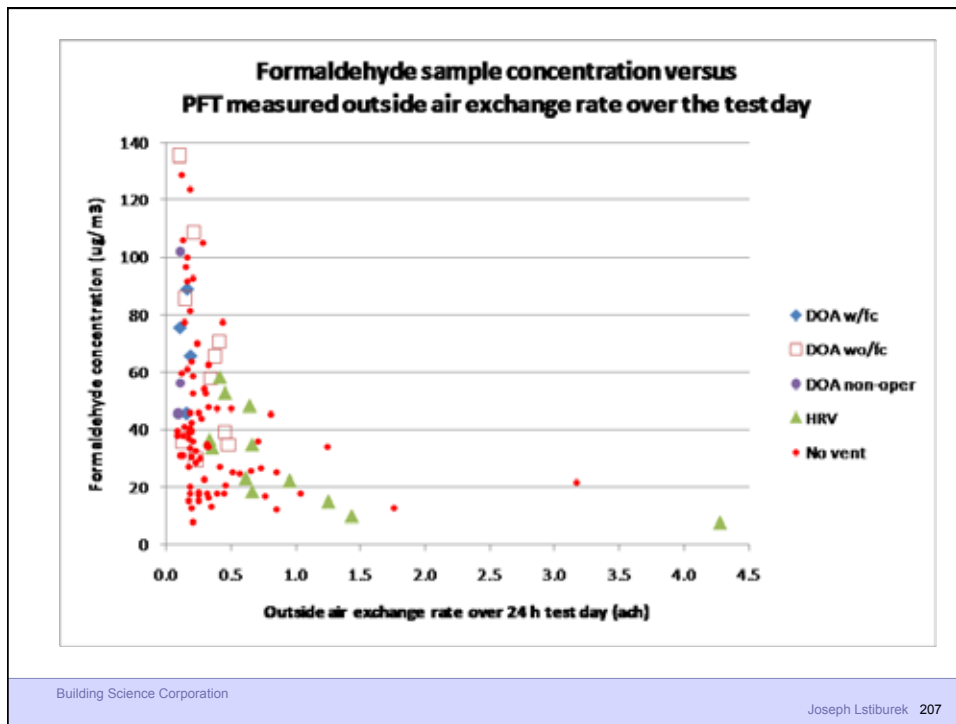

ASHRAE Standard 62.2 calls for 7.5 cfm per person plus 0.03 cfm per square foot of conditioned area

Occupancy is deemed to be the number of bedrooms plus one

ASHRAE Standard 62.2 calls for 7.5 cfm per person plus 0.03 cfm per square foot of conditioned area

Occupancy is deemed to be the number of bedrooms plus one

Outcome is often bad – part load humidity problems, dryness problems, energy problems

IRC 2015 and 2018 calls for 7.5 cfm per person plus 0.01 cfm per square foot of conditioned area

Occupancy is deemed to be the number of bedrooms plus one

3 Bedroom House – 2,500 ft²
30 cfm plus 75 cfm
105 cfm

3 Bedroom House – 2,500 ft²
30 cfm plus 25 cfm
55 cfm

Dilution Is Not The Solution To Indoor Pollution Source Control

Building Science Corporation

Joseph Lstiburek 213

Dilution For People Source Control For The Building

Building Science Corporation

Joseph Lstiburek 214

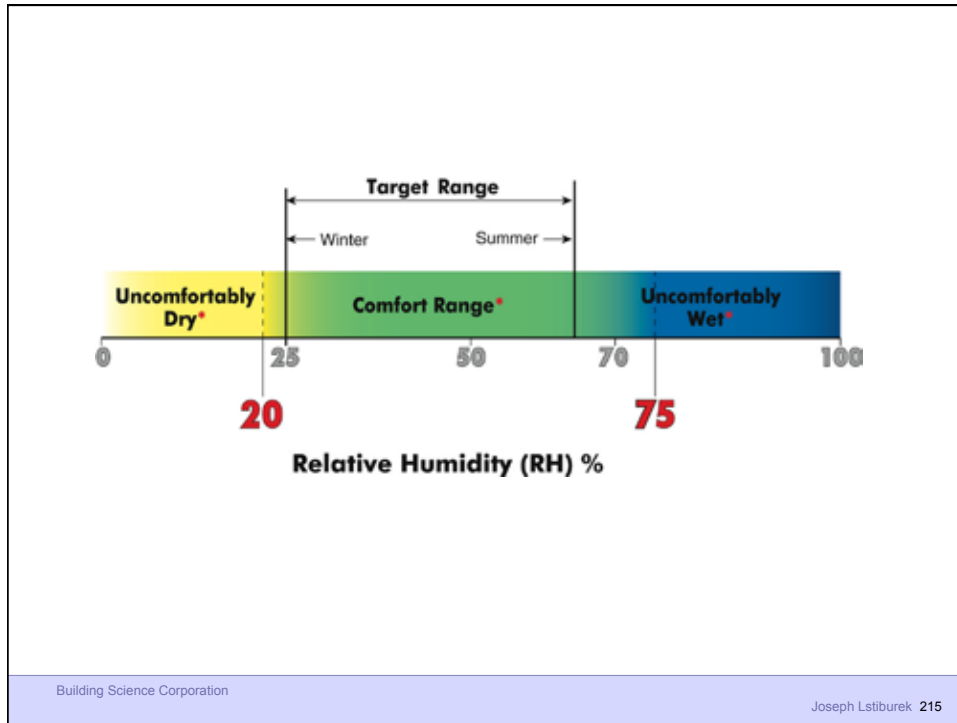

Recommended Range of Relative Humidity
Above 25 percent during winter
Below 70 percent during summer

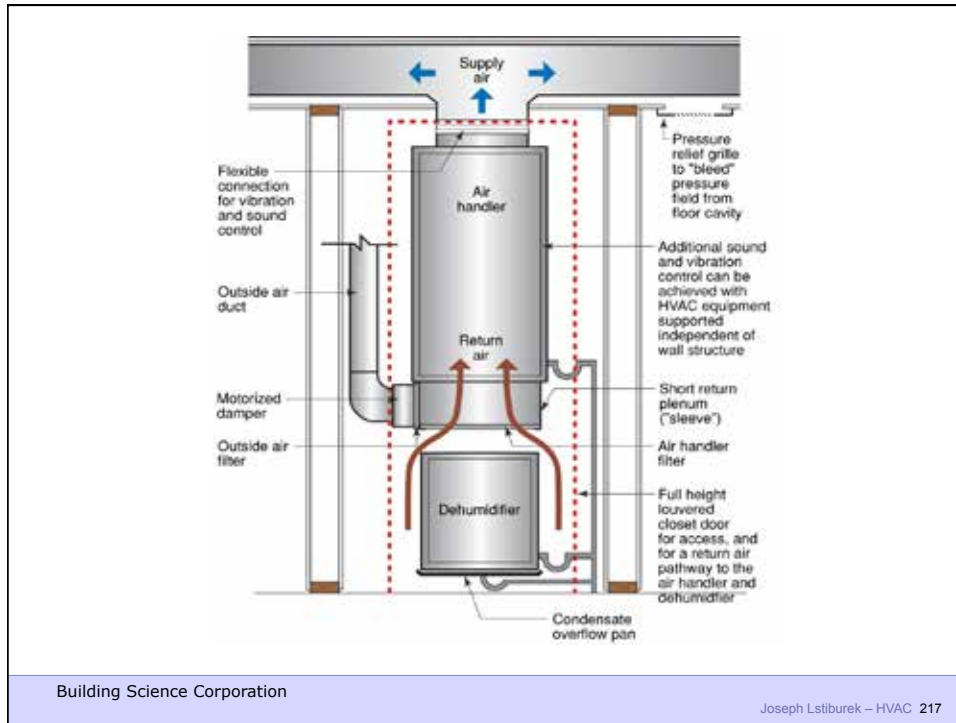

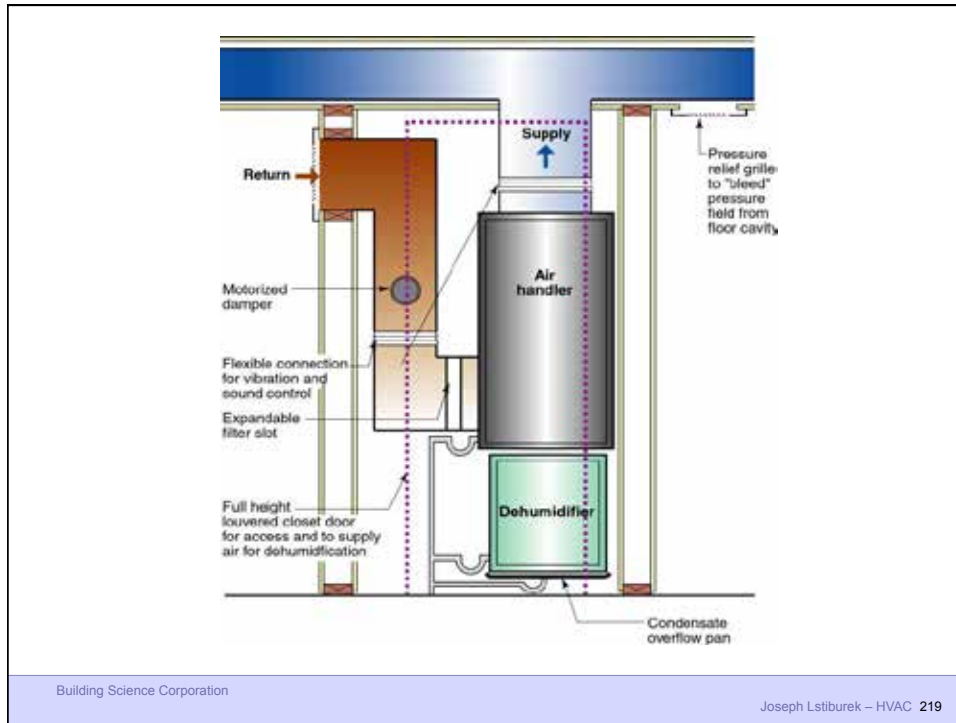

Kitchen Exhaust Hoods

Building Science Corporation

Joseph Lstiburek 221

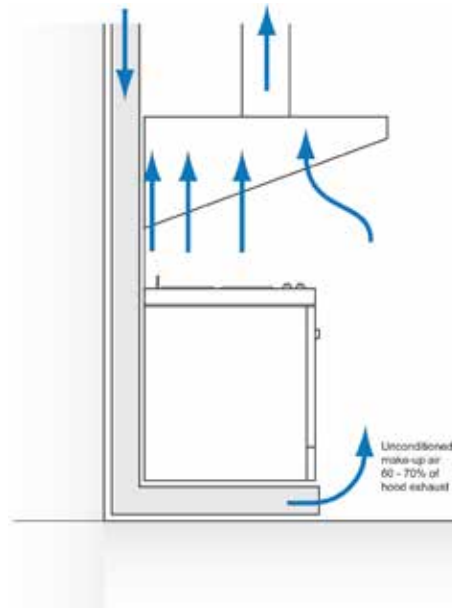

Building Science Corporation

Joseph Lstiburek 222



Building Science Corporation

Joseph Lstiburek 223

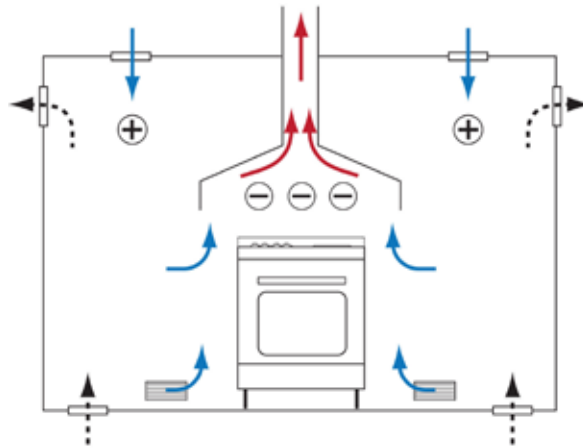

Building Science Corporation

Joseph Lstiburek 224

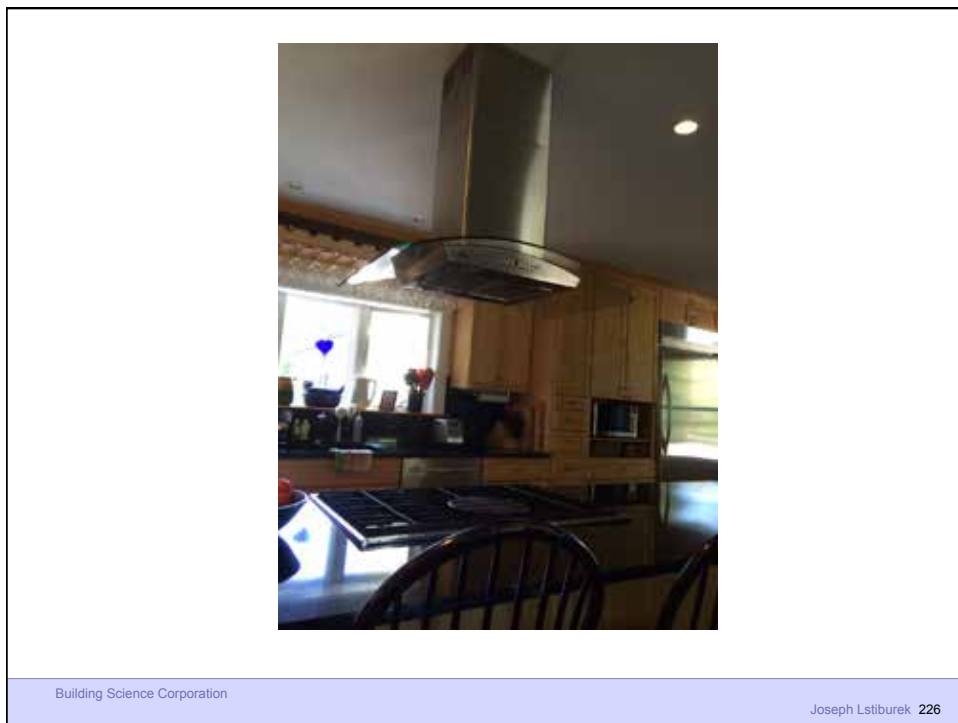
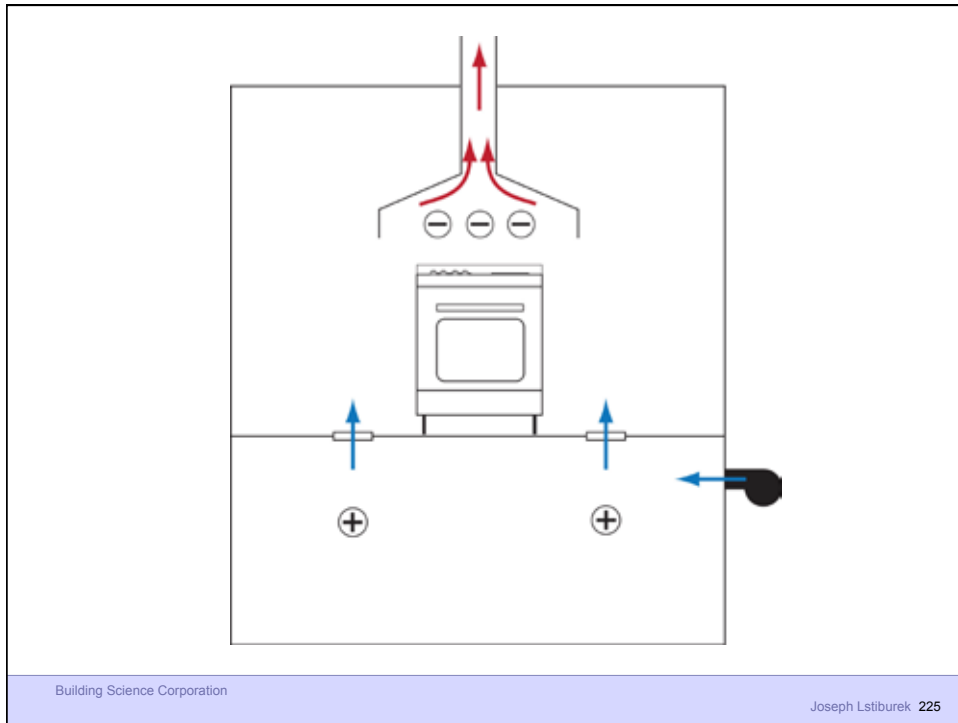

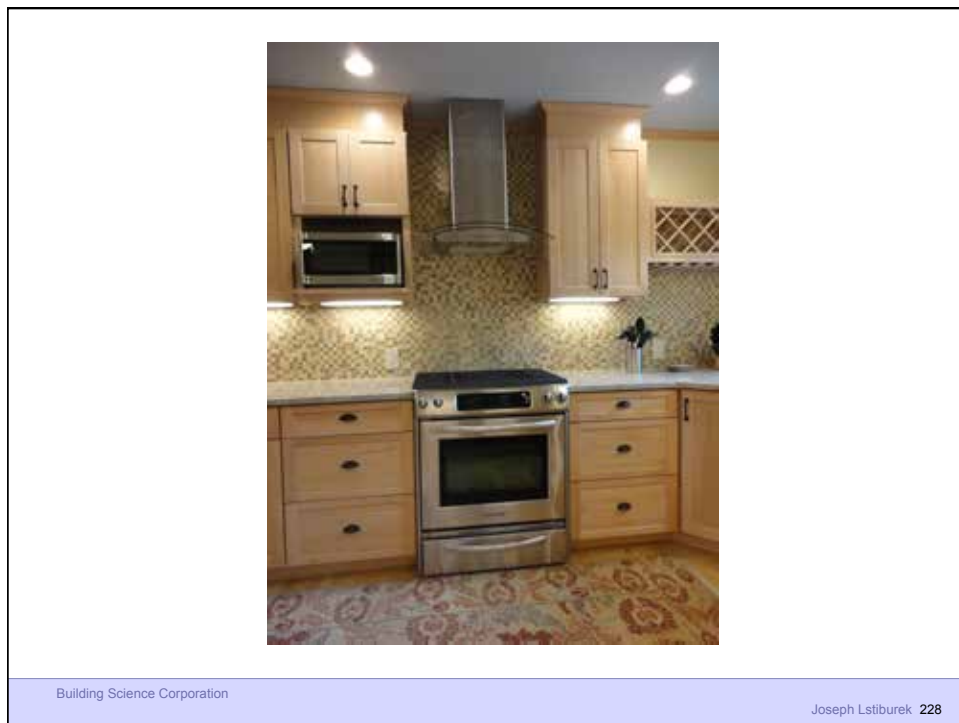

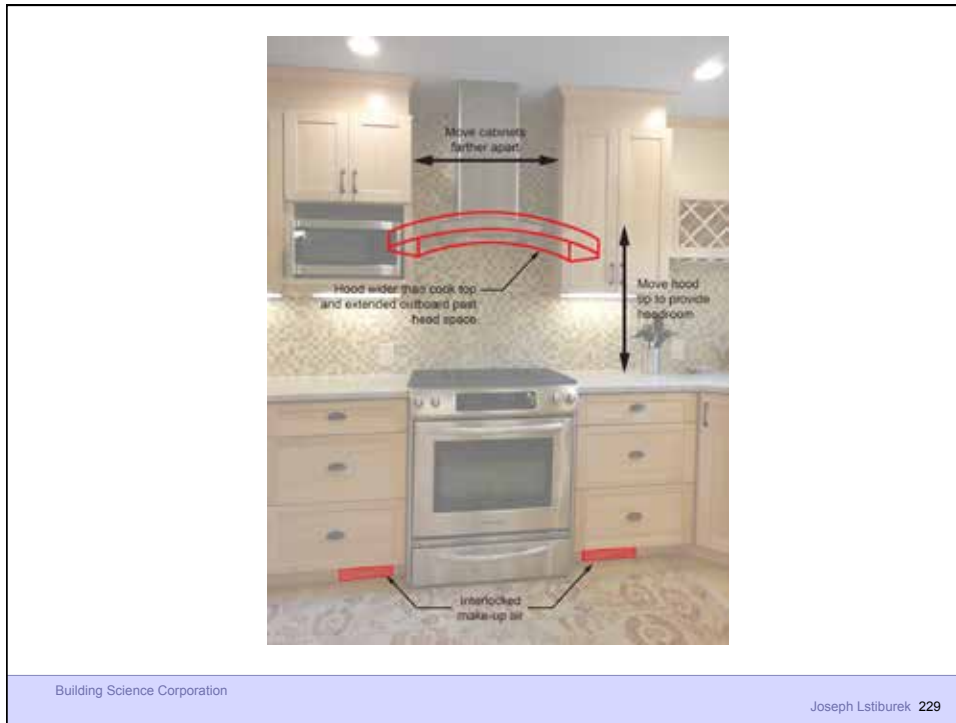

Clothes Dryers

Building Science Corporation

Joseph Lstiburek 231



Building Science Corporation

Joseph Lstiburek 232



Building Science Corporation

Joseph Lstiburek 233

Fireplaces

Building Science Corporation

Joseph Lstiburek 234

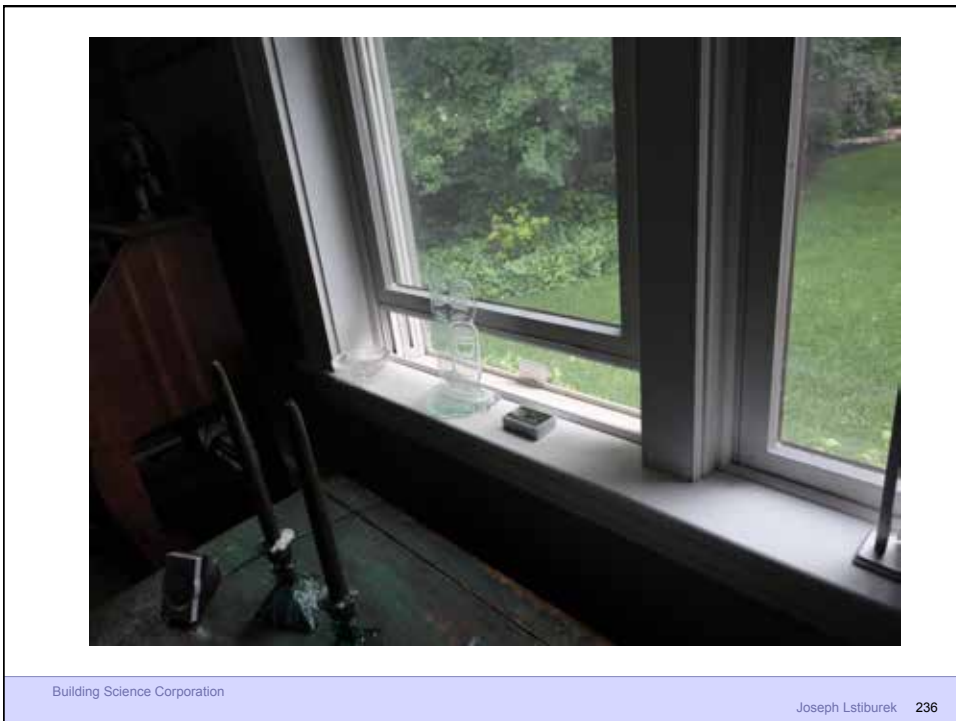



Building Science Corporation

Joseph Lstiburek 237

Approaches

Building Science Corporation

Joseph Lstiburek 238

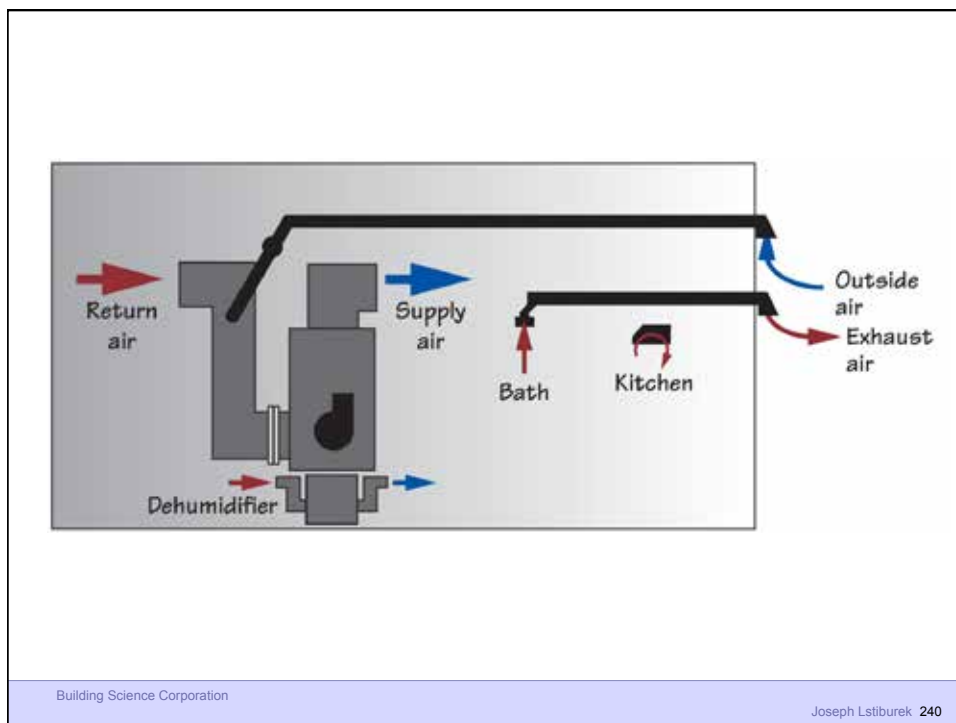
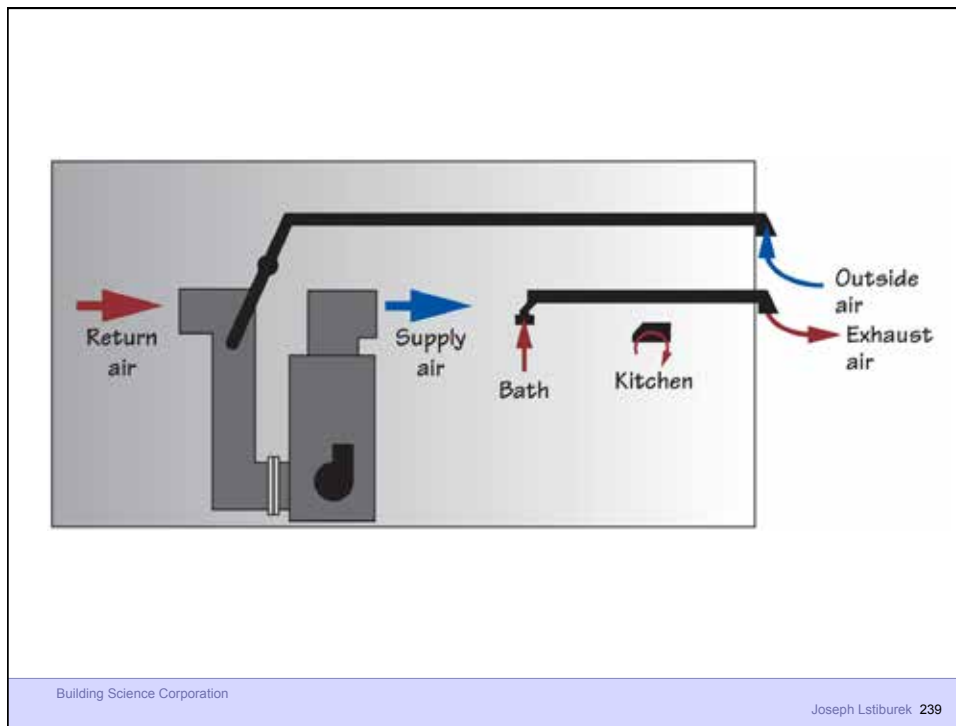

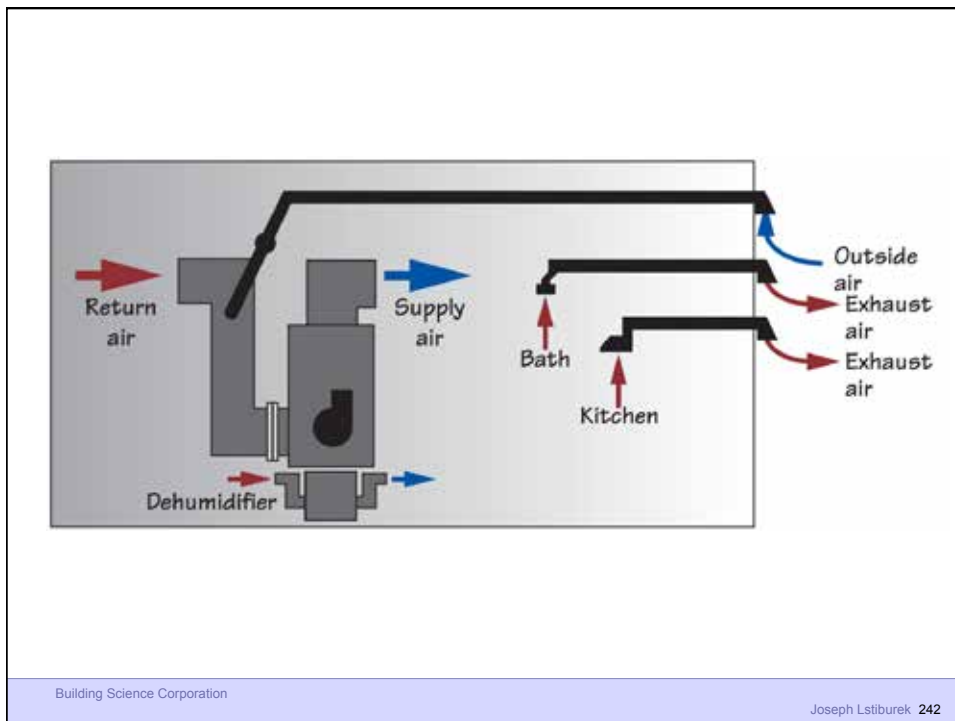
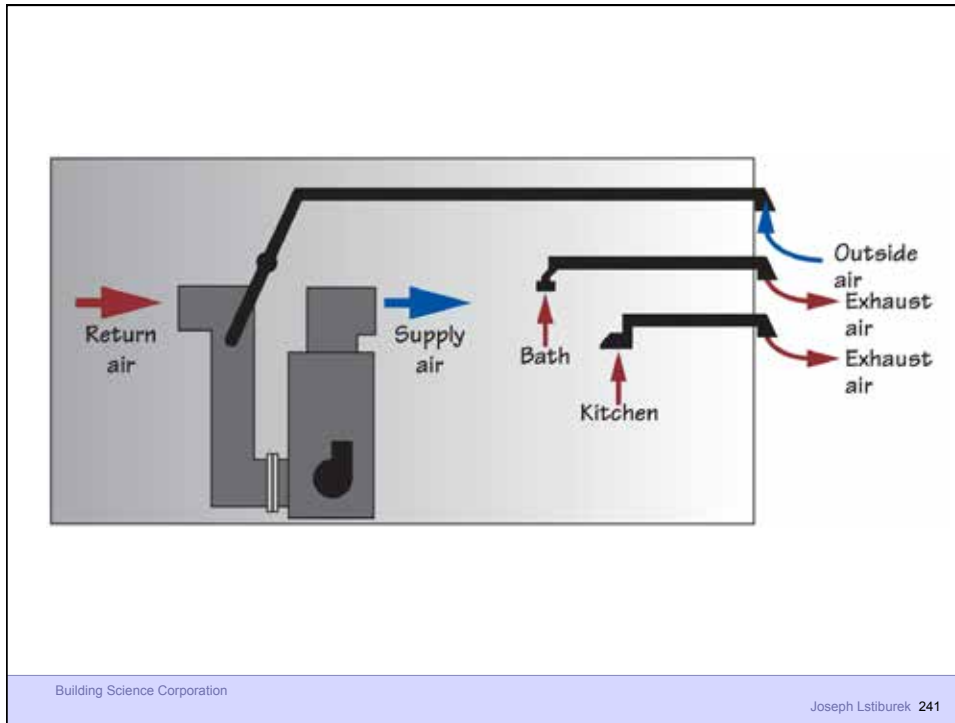

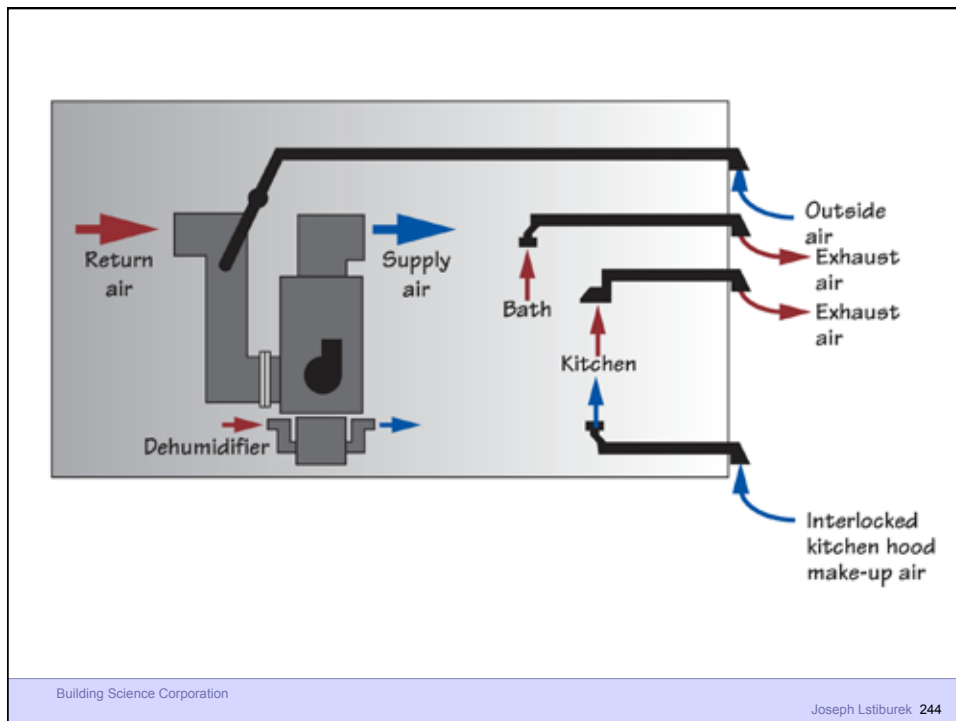
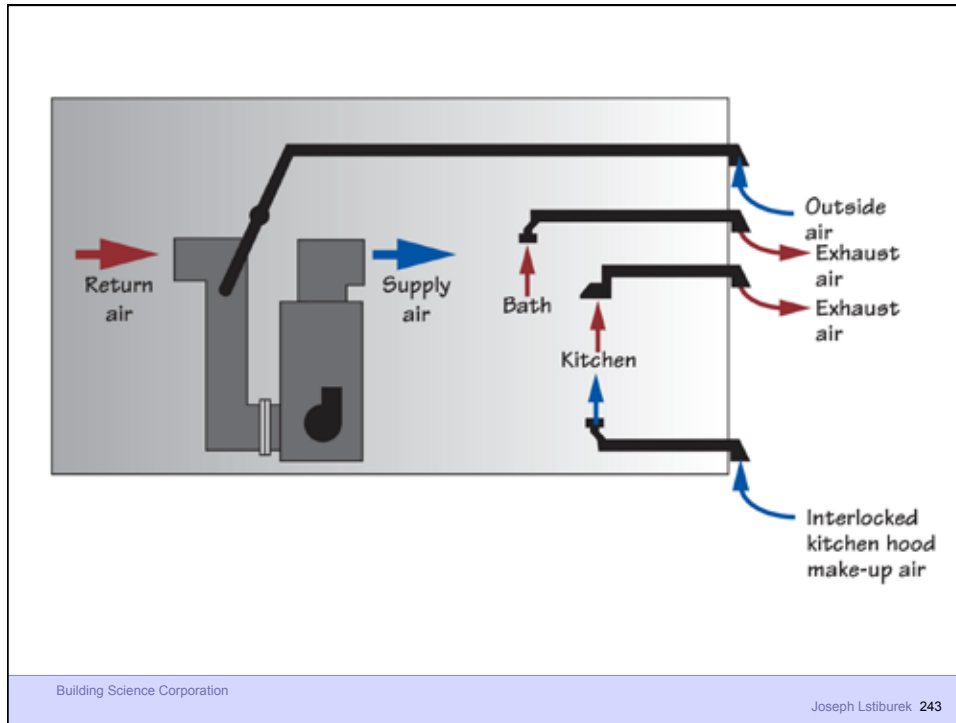

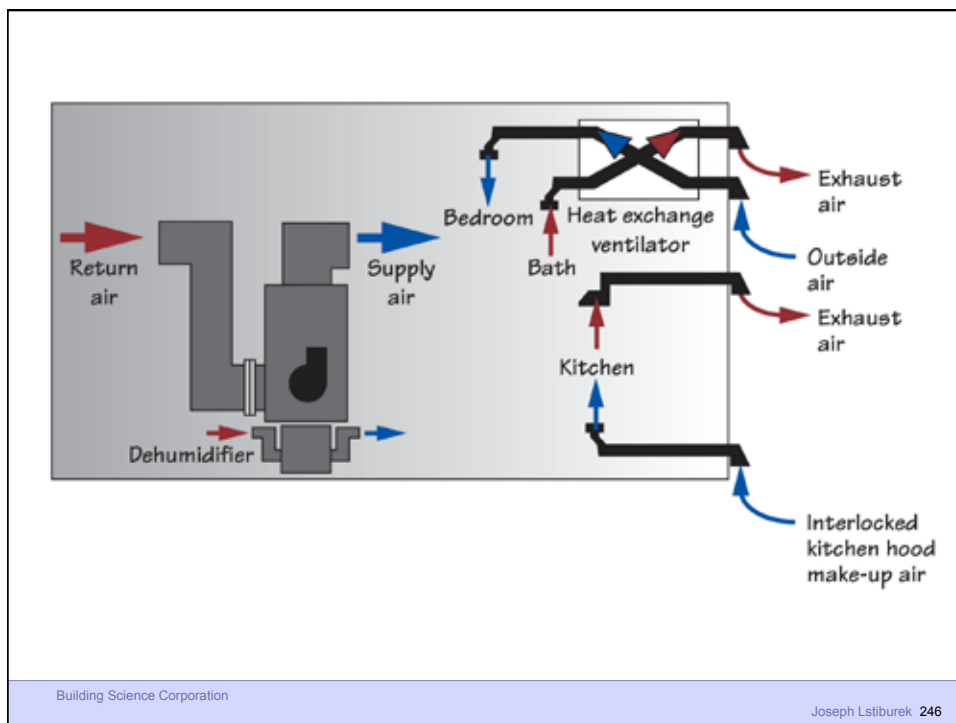
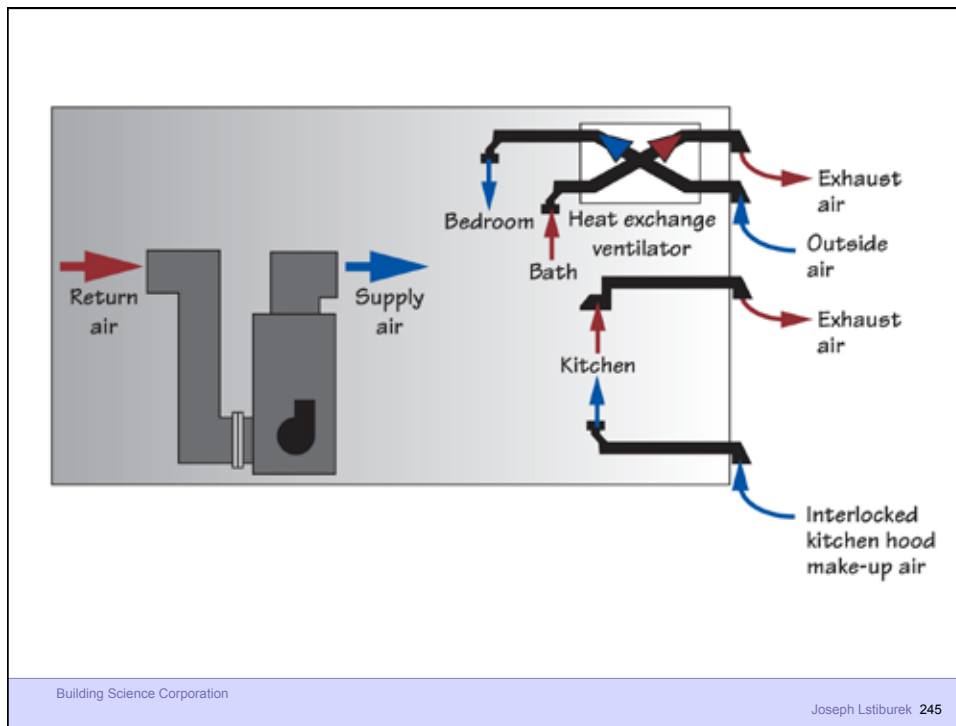

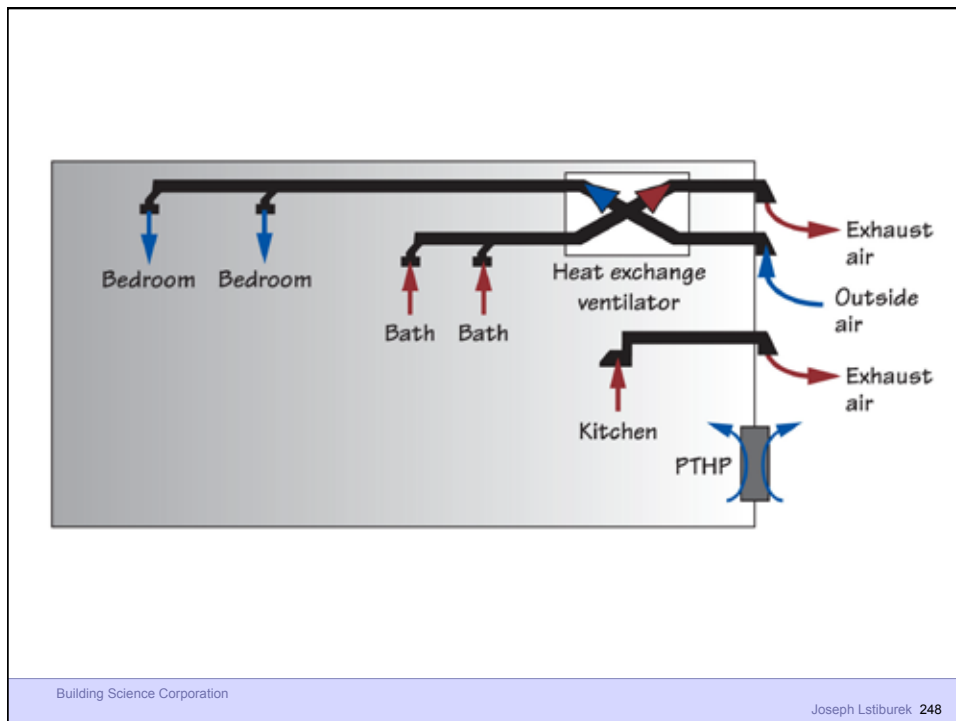
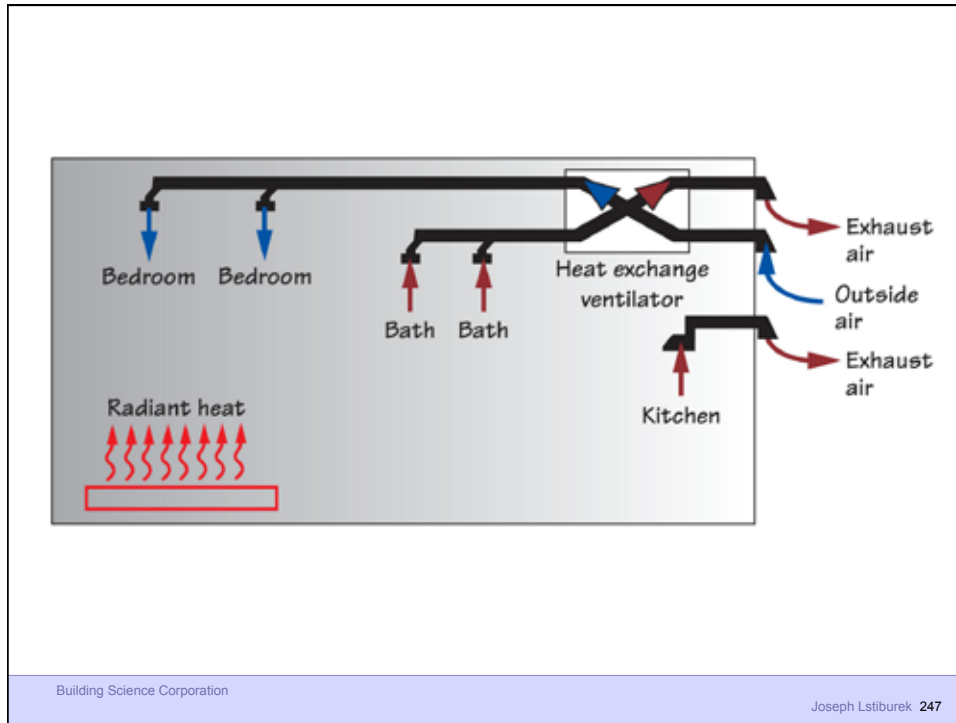

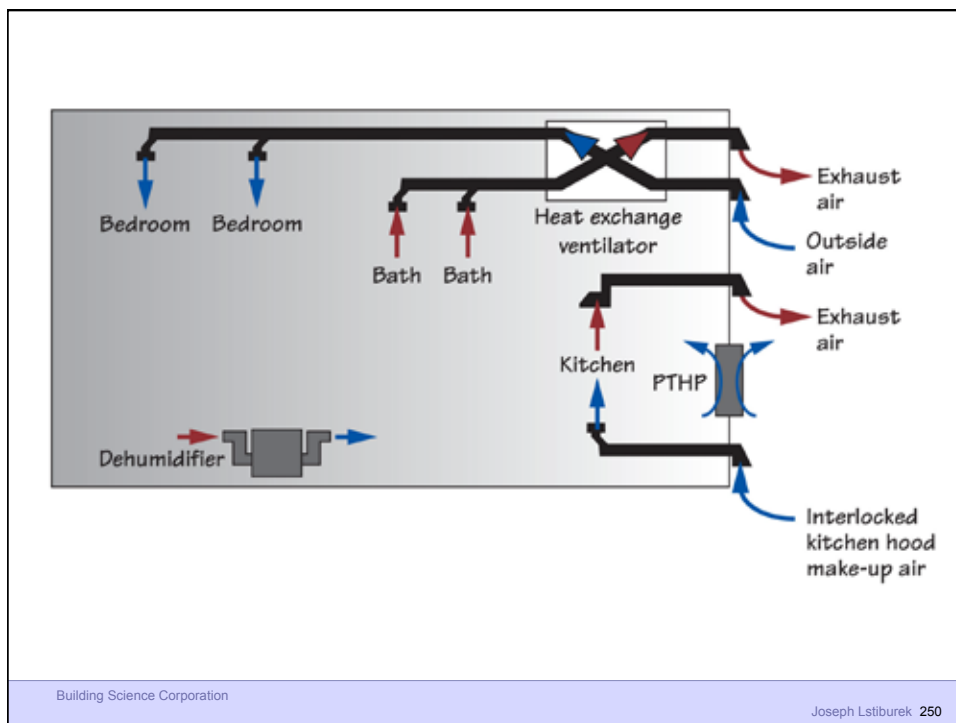
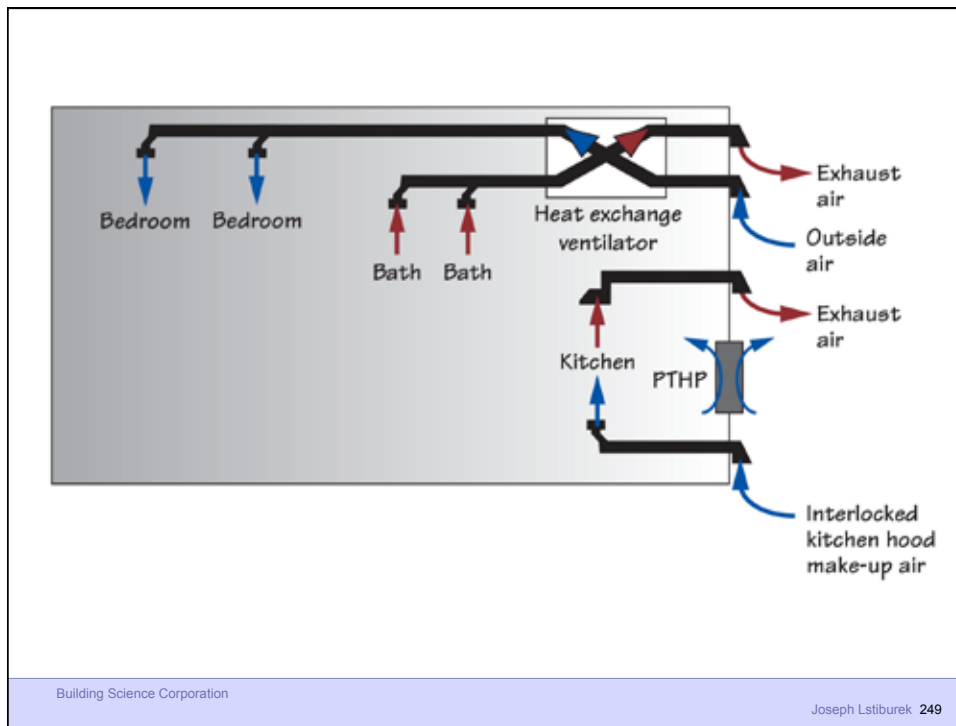



Build Tight - Ventilate Right

Build Tight - Ventilate Right

How Tight?

What's Right?

Building Science Corporation

Joseph Lstiburek 253

Air Barrier Metrics

Material	0.02 l/(s-m ²) @ 75 Pa
Assembly	0.20 l/(s-m ²) @ 75 Pa
Enclosure	2.00 l/(s-m ²) @ 75 Pa
	0.35 cfm/ft ² @ 50 Pa
	0.25 cfm/ft ² @ 50 Pa
	0.15 cfm/ft ² @ 50 Pa

Building Science Corporation

Joseph Lstiburek 254

Getting rid of big holes	3 ach@50
Getting rid of smaller holes	1.5 ach@50
Getting German	0.6 ach@50

Best

As Tight as Possible - with -
Balanced Ventilation
Energy Recovery
Distribution and Mixing
Source Control - Spot exhaust ventilation
Filtration
Material selection