

Joseph Lstiburek, Ph.D., P.Eng, ASHRAE Fellow

Building Science

Adventures In Building Science

presented by www.buildingscience.com

Build Tight - Ventilate Right

Building Science Corporation

Joseph Lstiburek 2

Build Tight - Ventilate Right

How Tight?

What's Right?

Building Science Corporation

Joseph Lstiburek 3

Air Barrier Metrics

Material	0.02 l/(s-m2) @ 75 Pa
Assembly	0.20 l/(s-m2) @ 75 Pa
Enclosure	2.00 l/(s-m2) @ 75 Pa
	0.35 cfm/ft2 @ 50 Pa
	0.25 cfm/ft2 @ 50 Pa
	0.15 cfm/ft2 @ 50 Pa

Building Science Corporation

Joseph Lstiburek 4

Getting rid of big holes	3 ach@50
Getting rid of smaller holes	1.5 ach@50
Getting German	0.6 ach@50

Building Science Corporation Joseph Lstiburek 5

Best

As Tight as Possible - with -
Balanced Ventilation
Energy Recovery
Distribution and Mixing
Source Control - Spot exhaust ventilation
Filtration
Material selection

Building Science Corporation Joseph Lstiburek 6

Worst

Leaky - with – Nothing
Spot Ventilation in Bathroom/Kitchen
Exhaust Ventilation – with – No Distribution
and No Mixing

Building Science Corporation Joseph Lstiburek 7

Three Types of Controlled Ventilation
Systems

Exhaust Ventilation
Supply Ventilation
Balanced Ventilation

Building Science Corporation Joseph Lstiburek 8

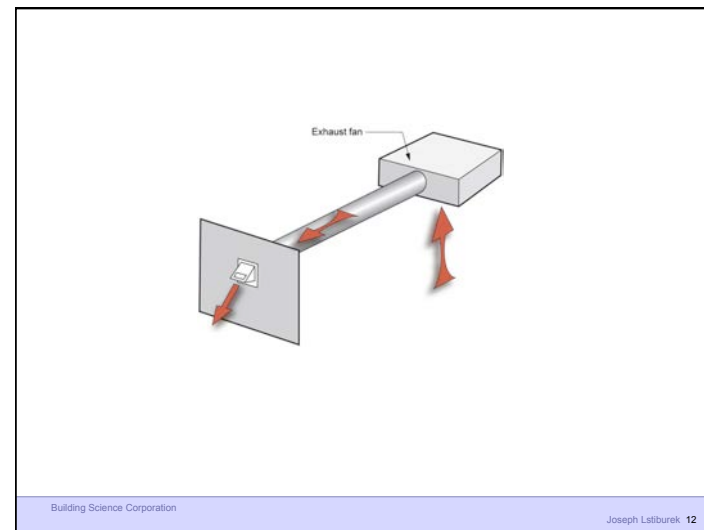
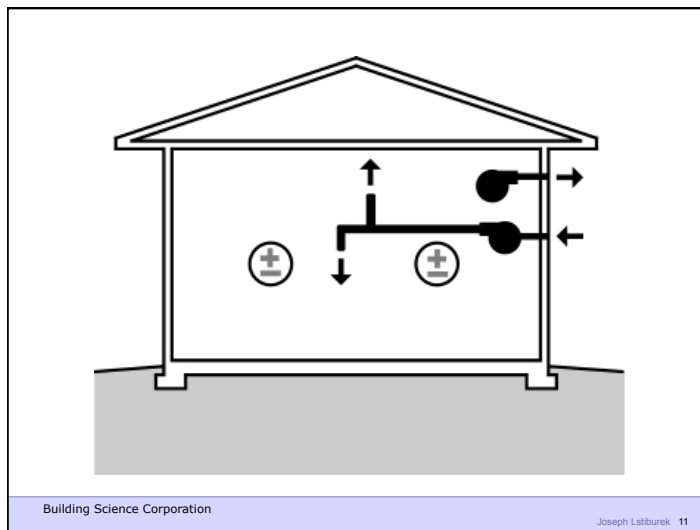
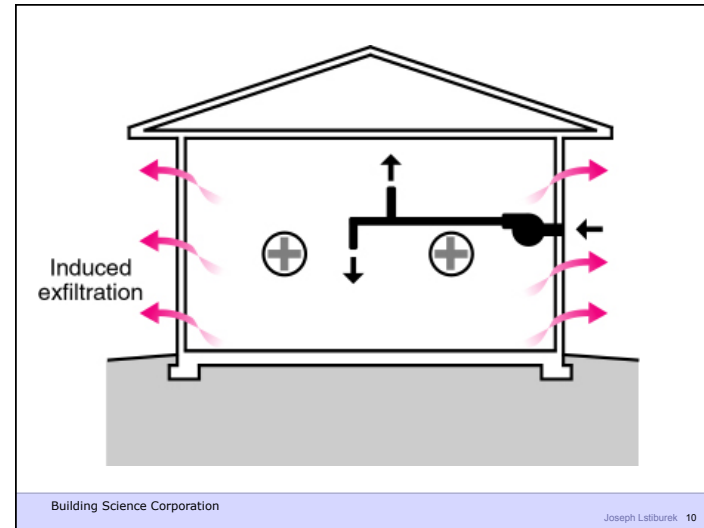
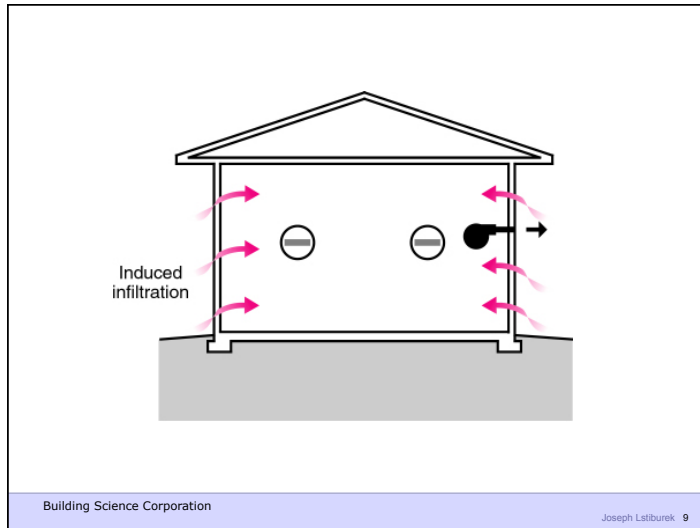

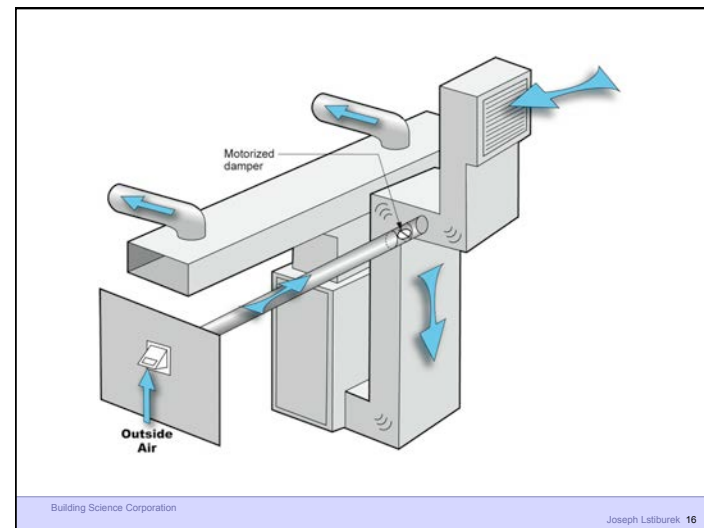
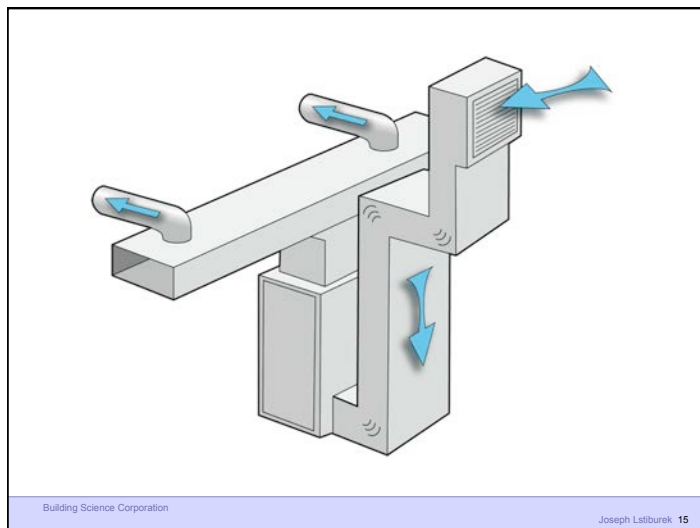
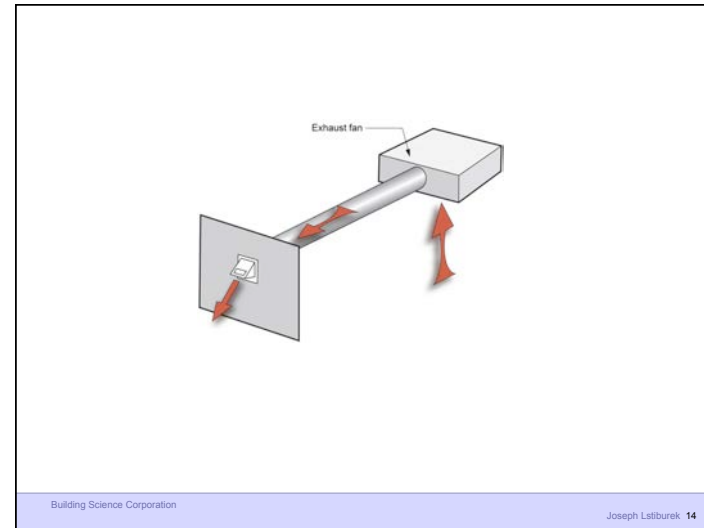
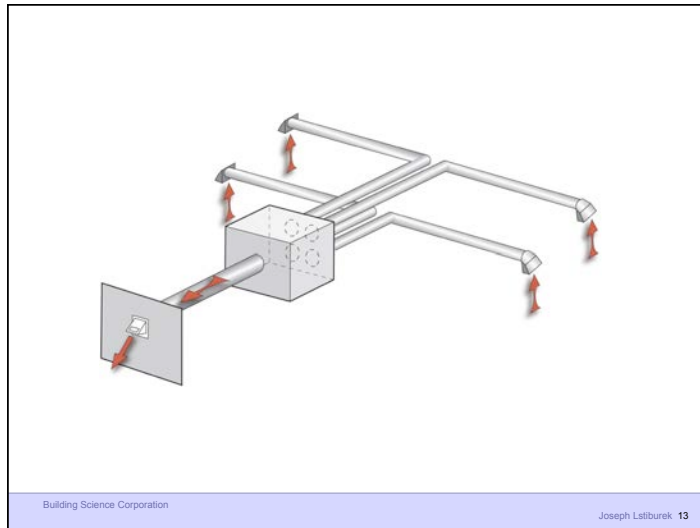

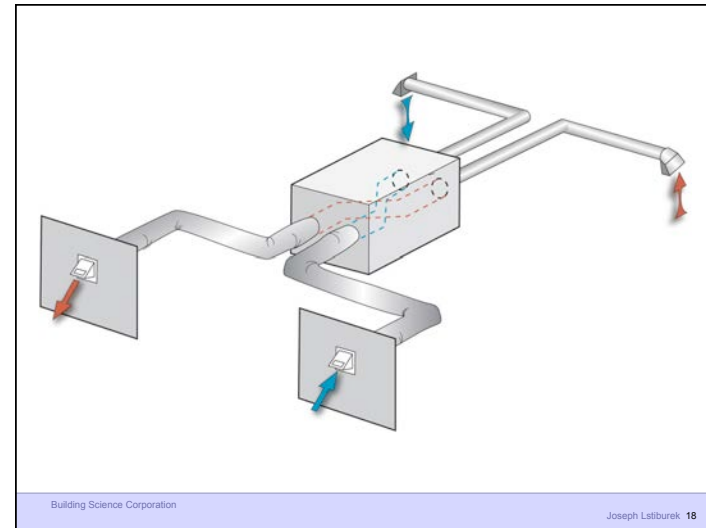
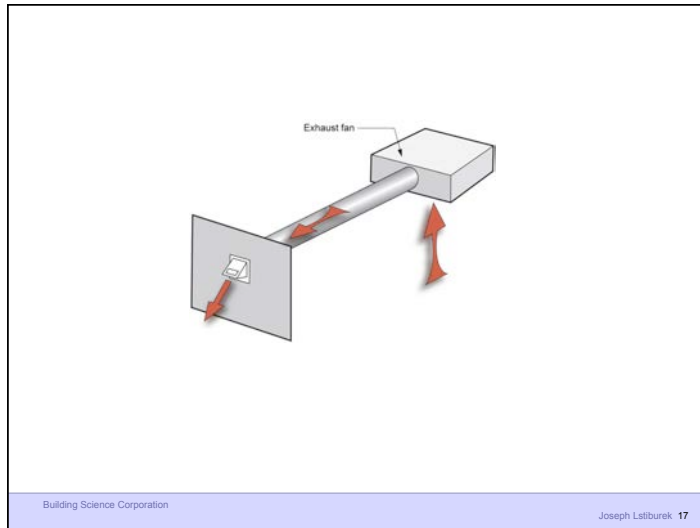

Ventilation Rates Are Based on Odor Control

Building Science Corporation Joseph Lstiburek 19

Ventilation Rates Are Based on Odor Control
Health Science Basis for Ventilation Rates is
Extremely Limited

Building Science Corporation Joseph Lstiburek 20

Ventilation Rates Are Based on Odor Control
 Health Science Basis for Ventilation Rates is
 Extremely Limited
 Almost Nothing Cited Applies to Housing

Building Science Corporation Joseph Lstiburek 21

Ventilation Rates Are Based on Odor Control
 Health Science Basis for Ventilation Rates is
 Extremely Limited
 Almost Nothing Cited Applies to Housing
 The Applicable Studies Focus on Dampness

Building Science Corporation Joseph Lstiburek 22

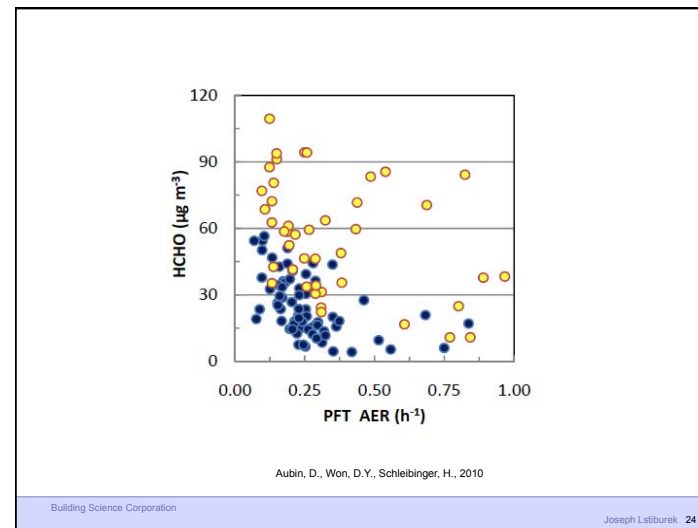
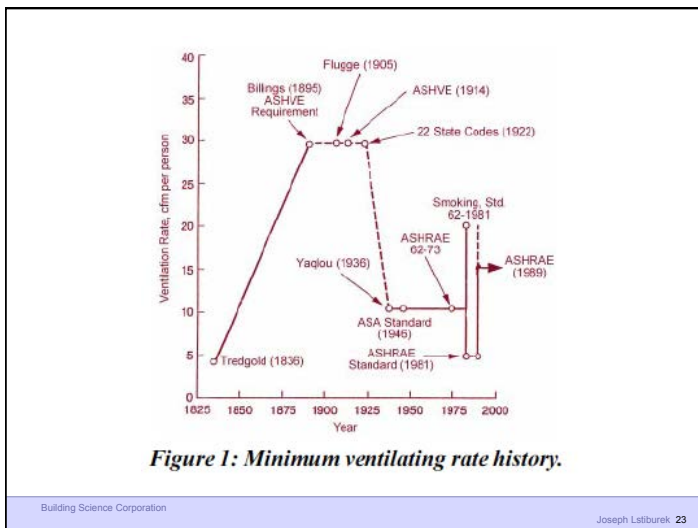

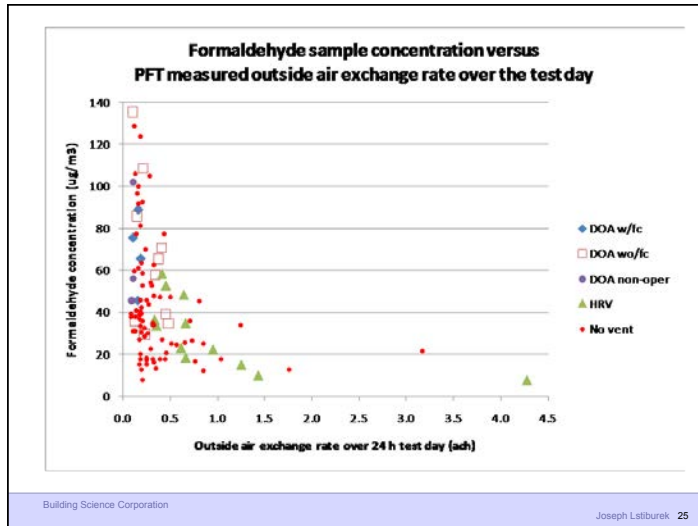

Dilution Is Not The Solution To Indoor Pollution Source Control

Building Science Corporation Joseph Lstiburek 26

Dilution For People Source Control For The Building

Building Science Corporation Joseph Lstiburek 27

ASHRAE Standard 62.2 calls for 7.5 cfm per person plus 0.03 cfm per square foot of conditioned area
Occupancy is deemed to be the number of bedrooms plus one

Building Science Corporation Joseph Lstiburek 28

ASHRAE Standard 62.2 calls for 7.5 cfm per person plus 0.03 cfm per square foot of conditioned area

Occupancy is deemed to be the number of bedrooms plus one

Outcome is often bad – part load humidity problems, dryness problems, energy problems

Building Science Corporation Joseph Lstiburek 29

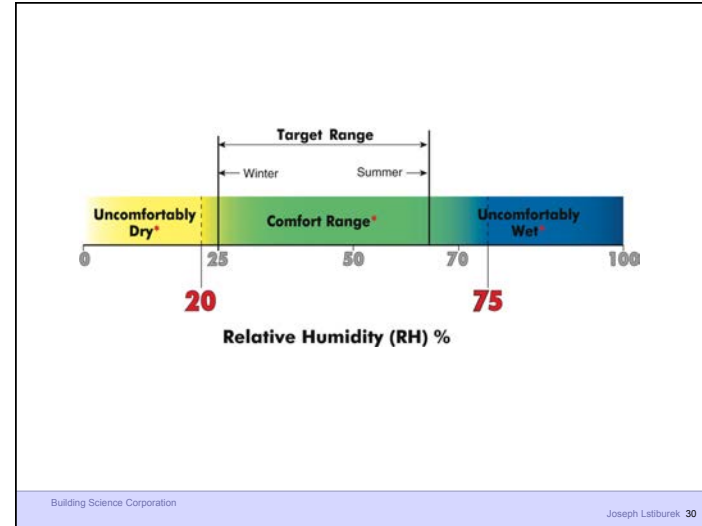

Recommended Range of Relative Humidity

Above 25 percent during winter

Below 70 percent during summer

Building Science Corporation Joseph Lstiburek – HVAC 32

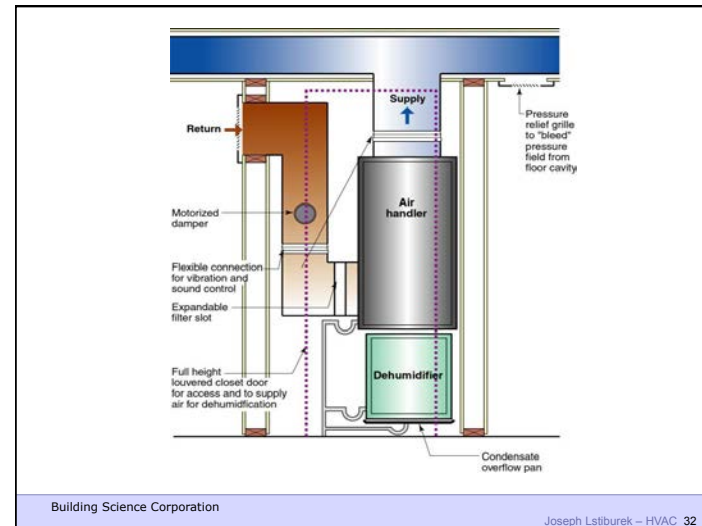

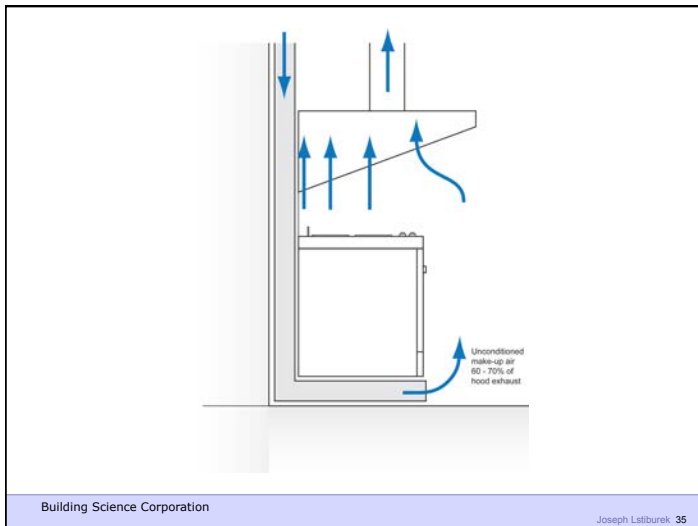
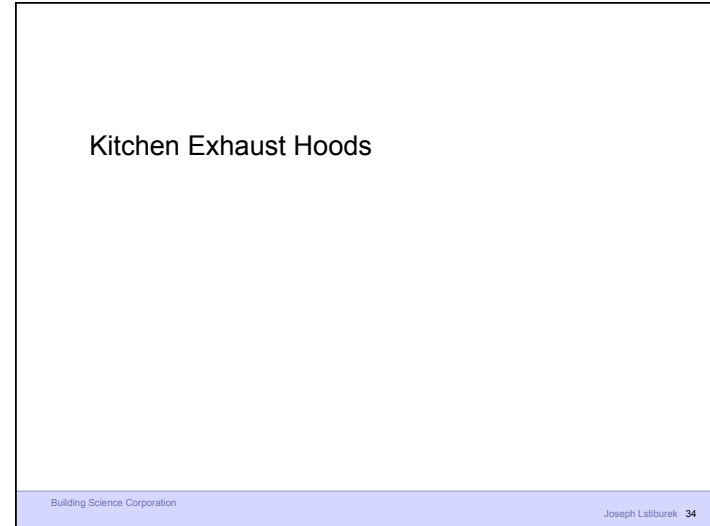

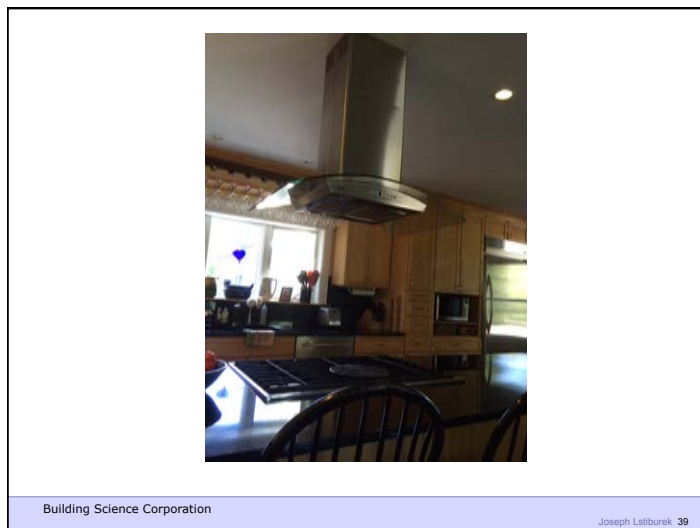
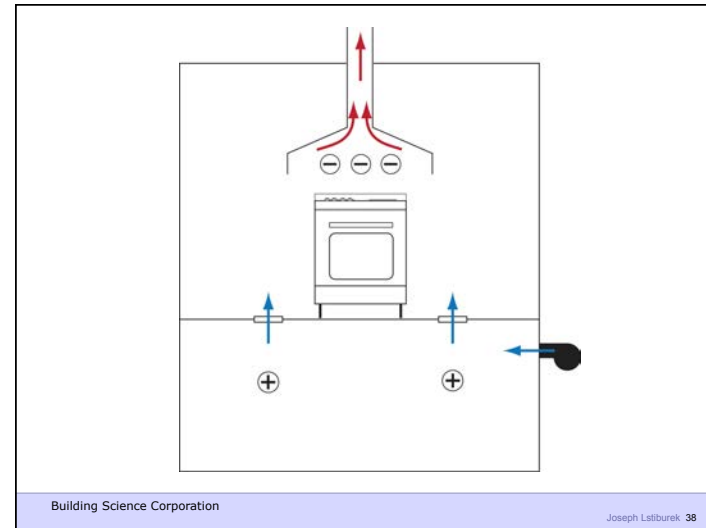
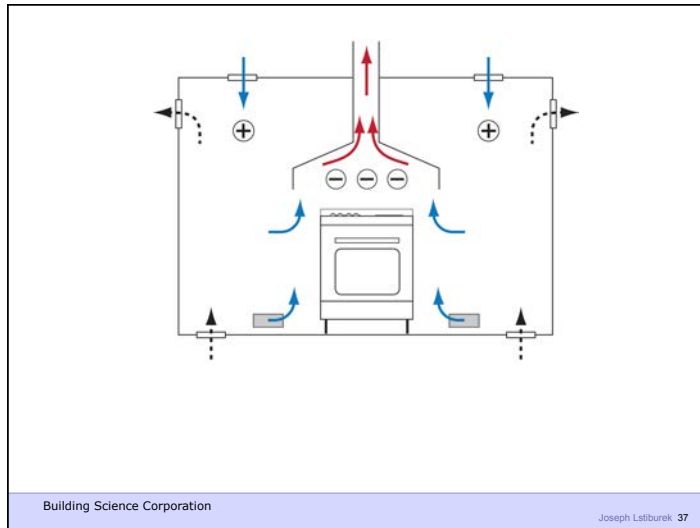

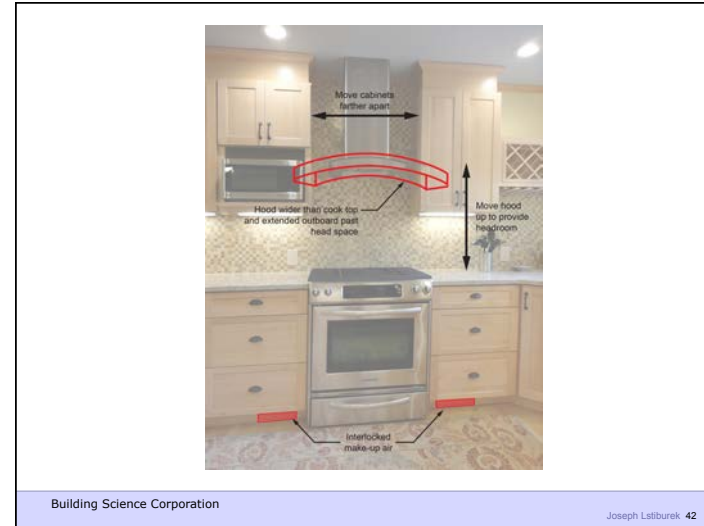
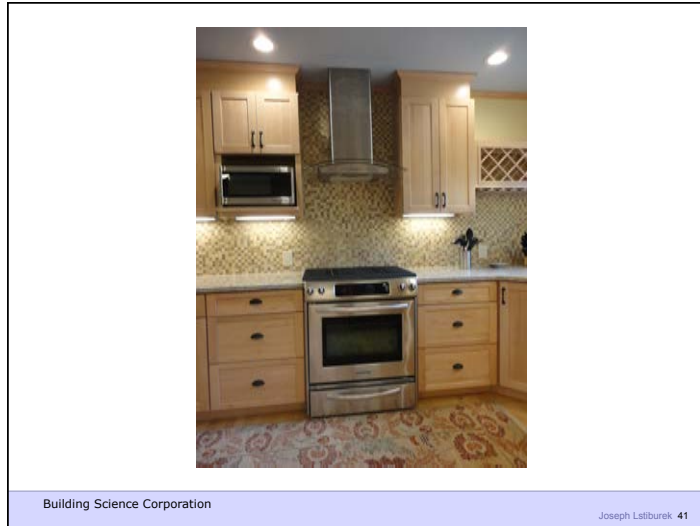

Clothes Dryers

Building Science Corporation Joseph Lstiburek 44

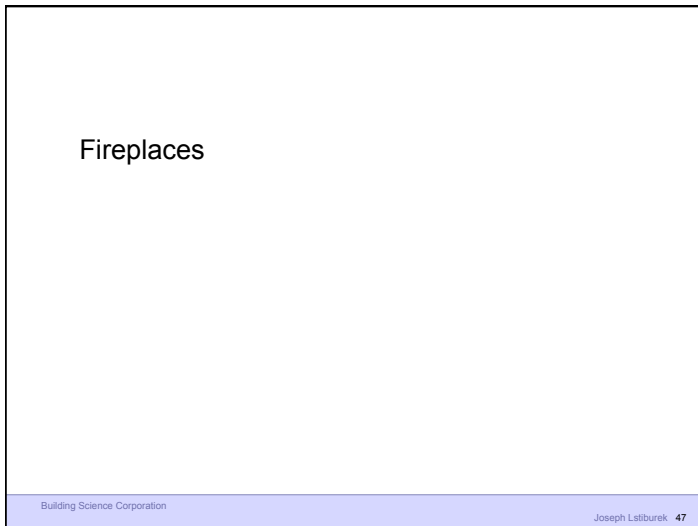

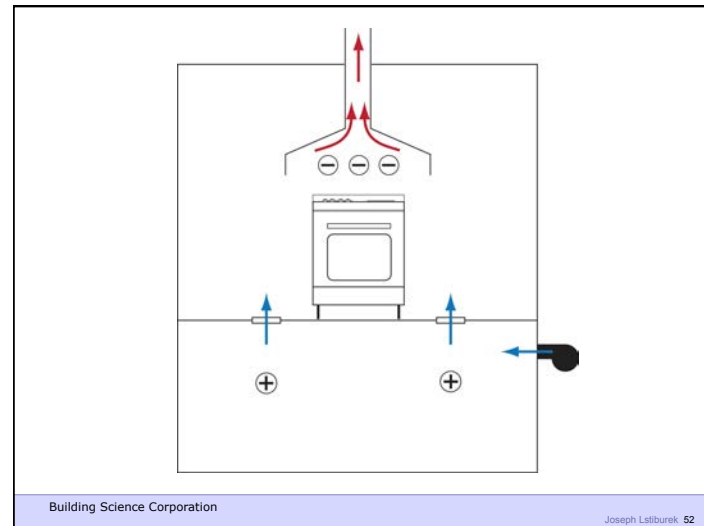
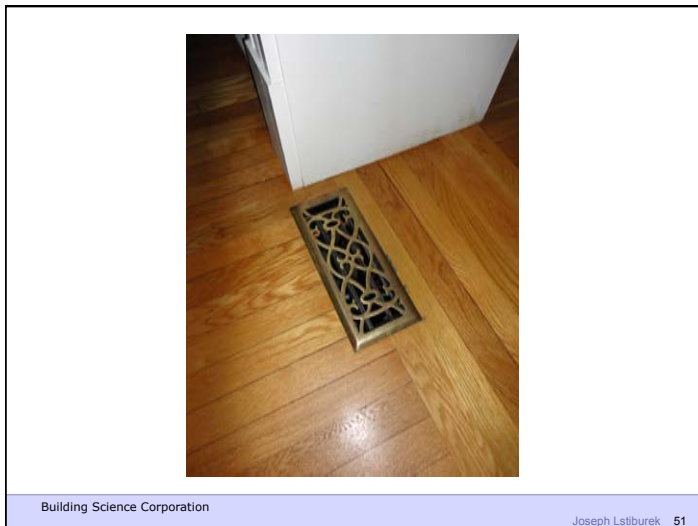
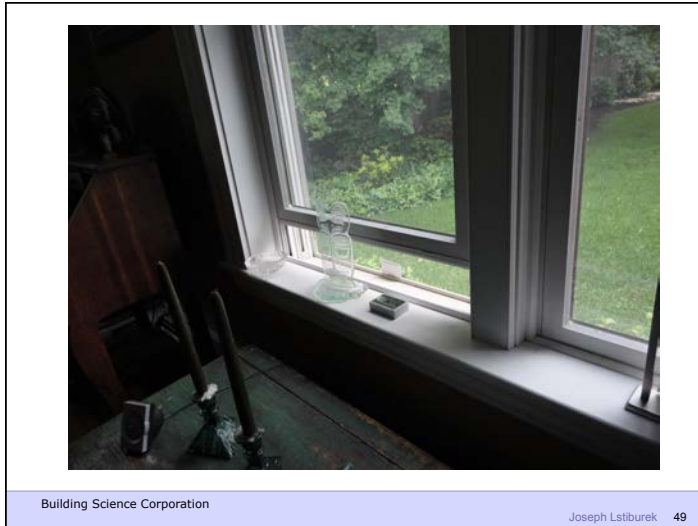

Approaches

Building Science Corporation Joseph Lstiburek 53

