

Joseph Lstiburek, Ph.D., P.Eng, ASHRAE Fellow

# Building Science

Adventures In Building Science

www.buildingscience.com

## What is a Building?

Building Science Corporation

Joseph Lstiburek 2

## A Building is an Environmental Separator

Building Science Corporation

Joseph Lstiburek 3

- Control heat flow
- Control airflow
- Control water vapor flow
- Control rain
- Control ground water
- Control light and solar radiation
- Control noise and vibrations
- Control contaminants, environmental hazards and odors
- Control insects, rodents and vermin
- Control fire
- Provide strength and rigidity
- Be durable
- Be aesthetically pleasing
- Be economical

Building Science Corporation

Joseph Lstiburek 4

Zeroth Law –  $A=B$  and  $B=C$  therefore  $A=C$   
First Law - Conservation of Energy  
Second Law - Entropy  
Third Law – Absolute Zero

Building Science Corporation Joseph Lstiburek 5

2<sup>nd</sup> Law of Thermodynamics

Building Science Corporation Joseph Lstiburek 6

In an isolated system, a process can occur only if it increases the total entropy of the system

Rudolf Clausius

Building Science Corporation Joseph Lstiburek 7

Heat Flow Is From Warm To Cold  
Moisture Flow Is From Warm To Cold  
Moisture Flow Is From More To Less  
Air Flow Is From A Higher Pressure to a Lower Pressure  
Gravity Acts Down

Building Science Corporation Joseph Lstiburek 8

Moisture Flow Is From Warm To Cold  
Moisture Flow Is From More To Less

Building Science Corporation Joseph Lstiburek 9

Moisture Flow Is From Warm To Cold  
Moisture Flow Is From More To Less

Thermal Gradient – Thermal Diffusion  
Concentration Gradient – Molecular Diffusion

Building Science Corporation Joseph Lstiburek 10

Moisture Flow Is From Warm To Cold  
Moisture Flow Is From More To Less

Thermal Gradient – Thermal Diffusion  
Concentration Gradient – Molecular Diffusion

Vapor Diffusion

Building Science Corporation Joseph Lstiburek 11

Thermodynamic Potential

Building Science Corporation Joseph Lstiburek 12

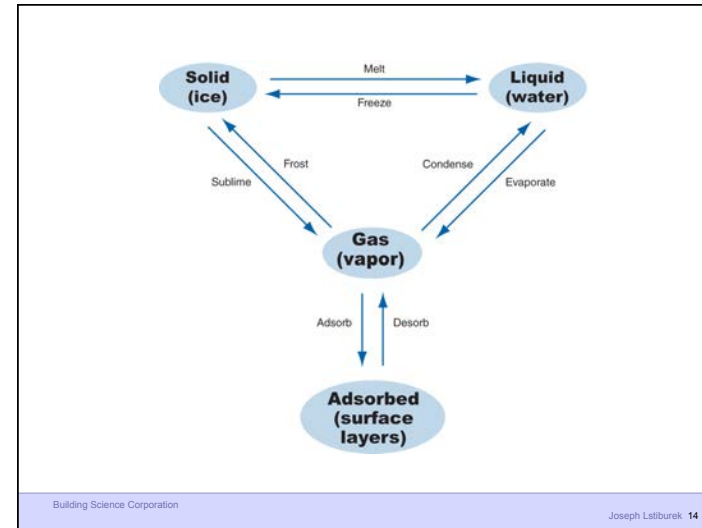
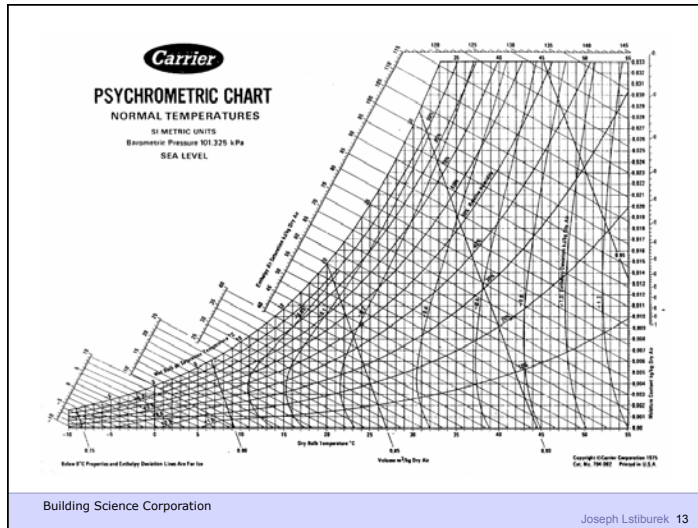

**Moisture Transport in Porous Media**

Phase	Transport Process	Driving Potential
<b>Vapor</b>	Diffusion	Vapor Concentration
<b>Adsorbate</b>	Surface Diffusion	Concentration
<b>Liquid</b>	Capillary Flow	Suction Pressure
	Osmosis	Solute Concentration

Building Science Corporation  
 Joseph Lstiburek 15

**Moisture Transport in Assemblies**

Phase	Transport Process	Driving Potential
<b>Vapor</b>	Diffusion	Vapor Concentration
	Convective Flow	Air Pressure
<b>Adsorbate</b>	Surface Diffusion	Concentration
<b>Liquid</b>	Capillary Flow	Suction Pressure
	Osmosis	Solute Concentration
	Gravitational Flow	Height
	Surface Tension	Surface Energy
	Momentum	Kinetic Energy
	Convective Flow	Air Pressure

Building Science Corporation  
 Joseph Lstiburek 16

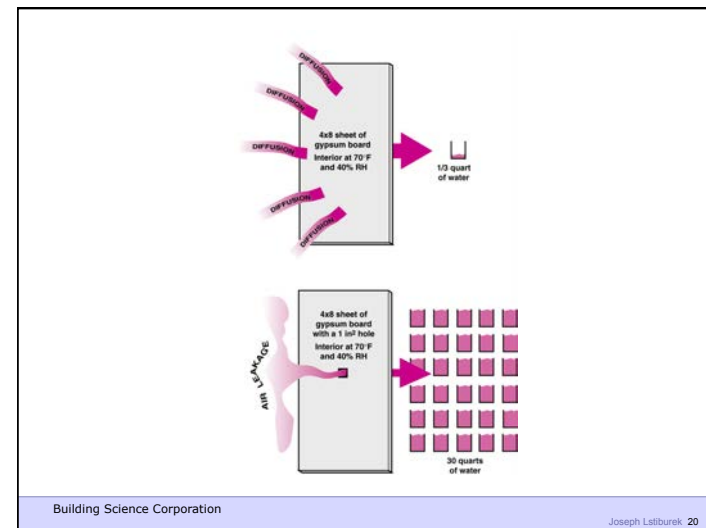
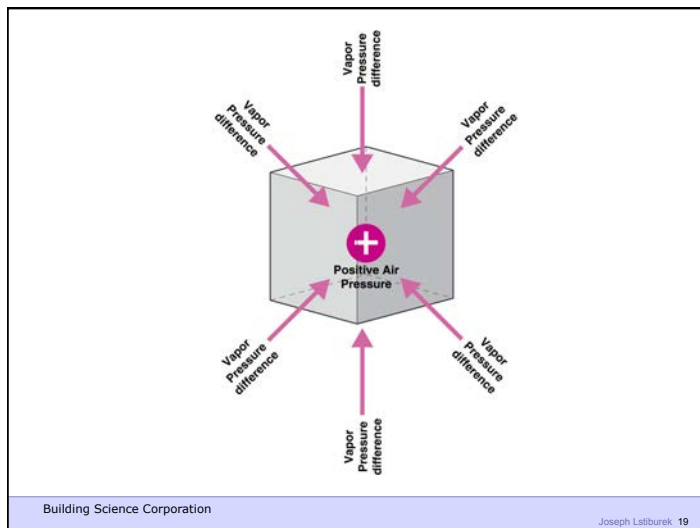
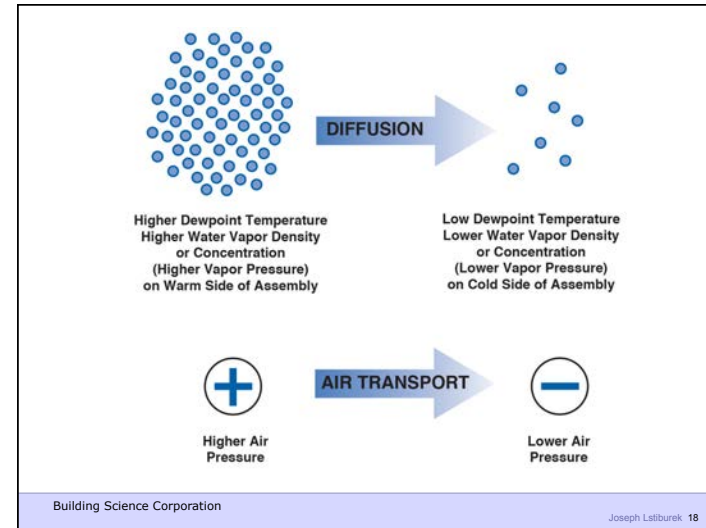
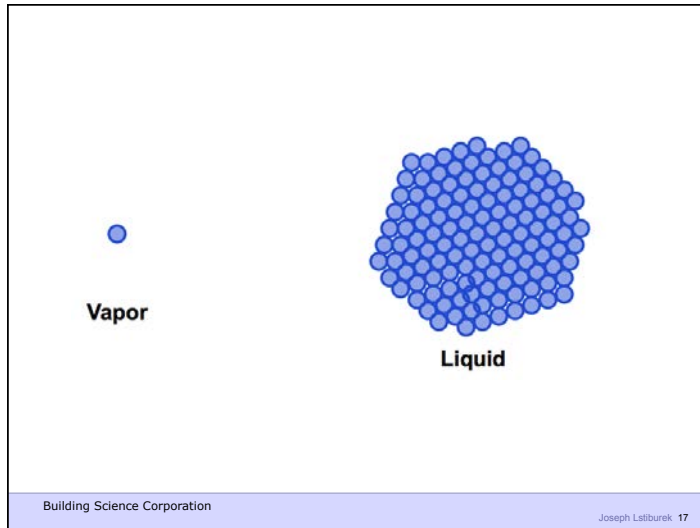

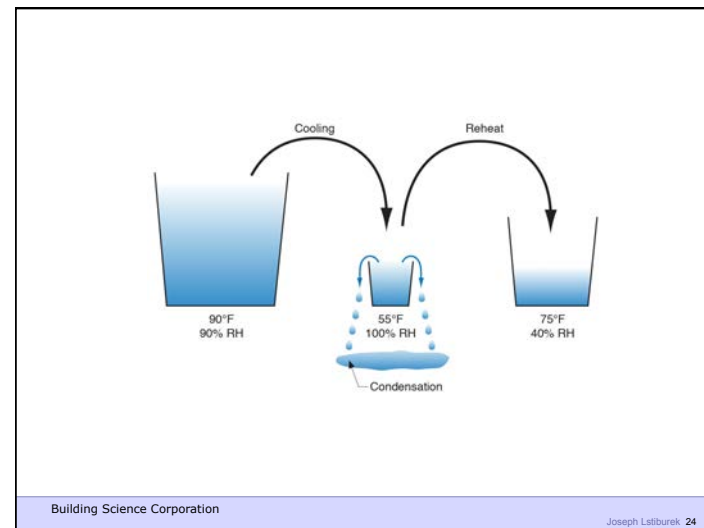
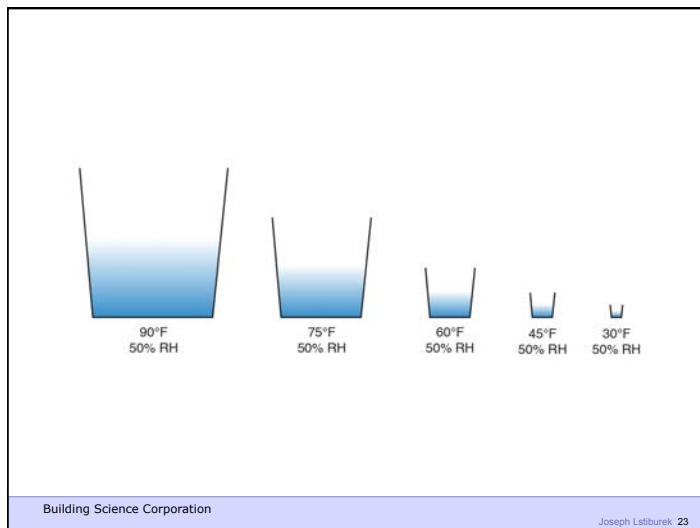
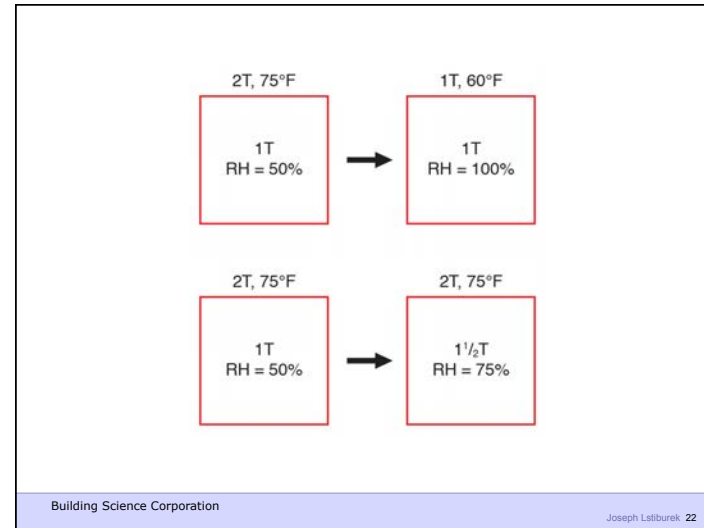
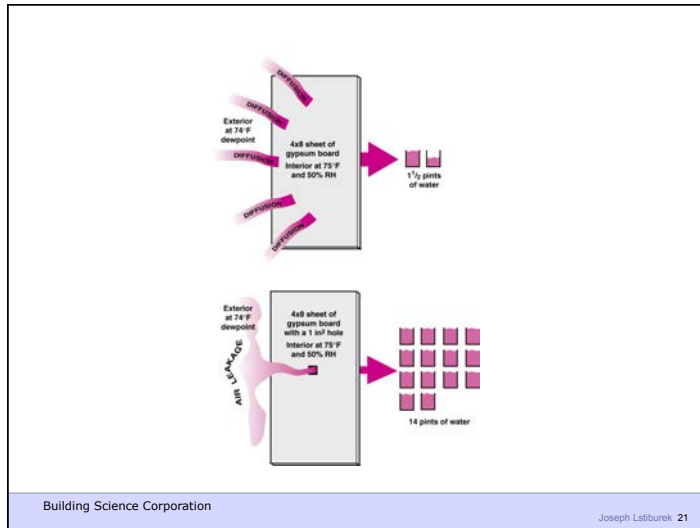

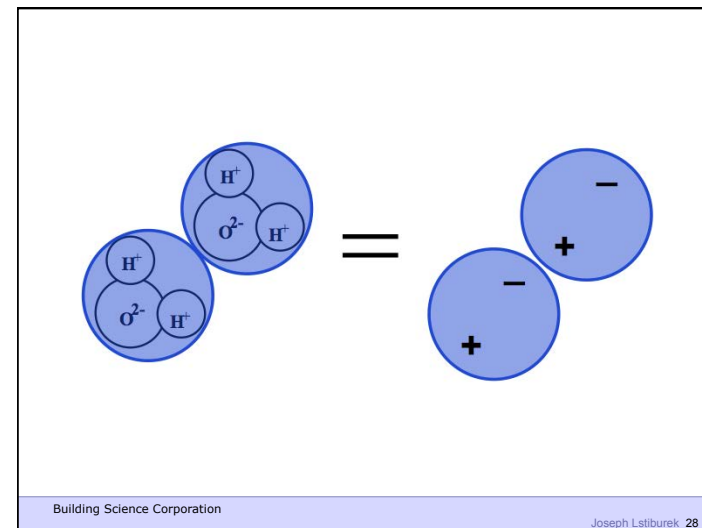
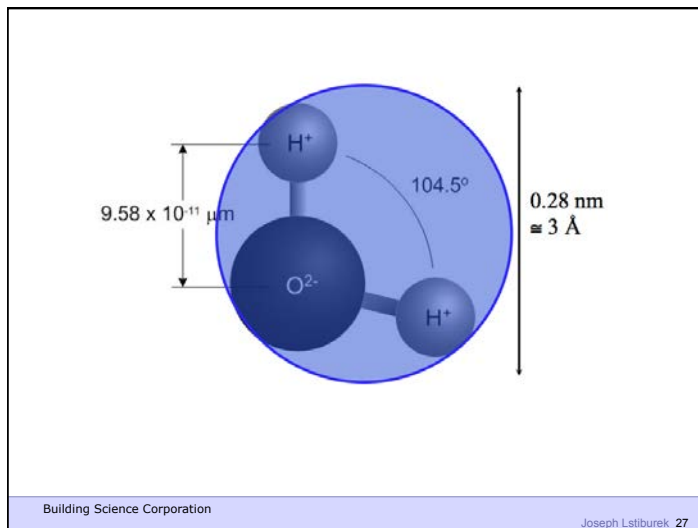
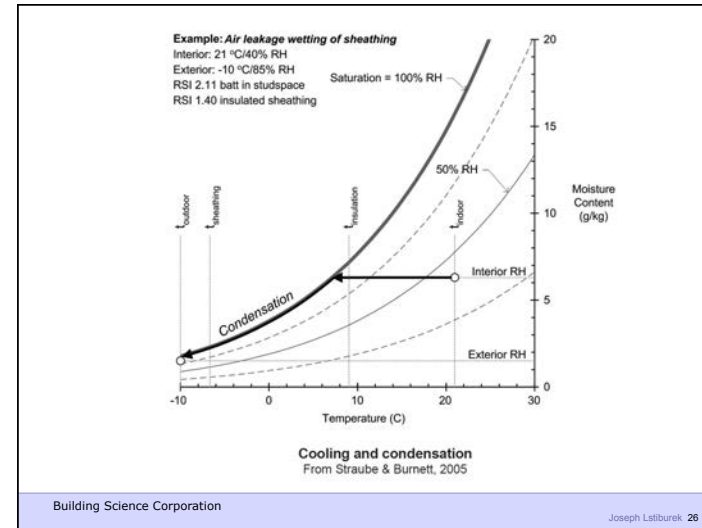
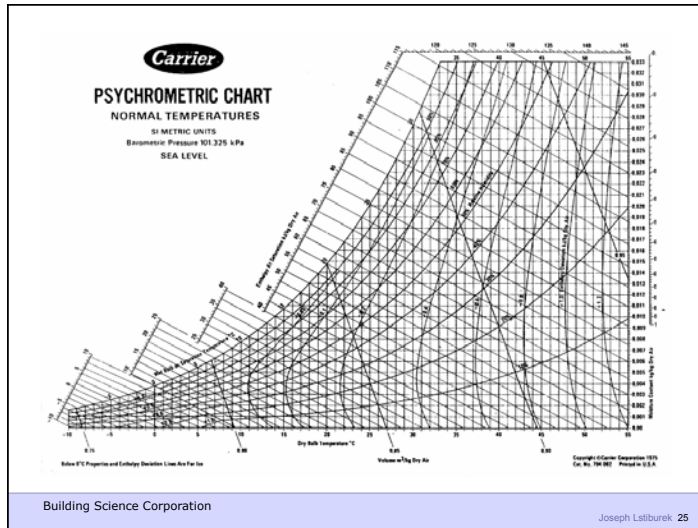

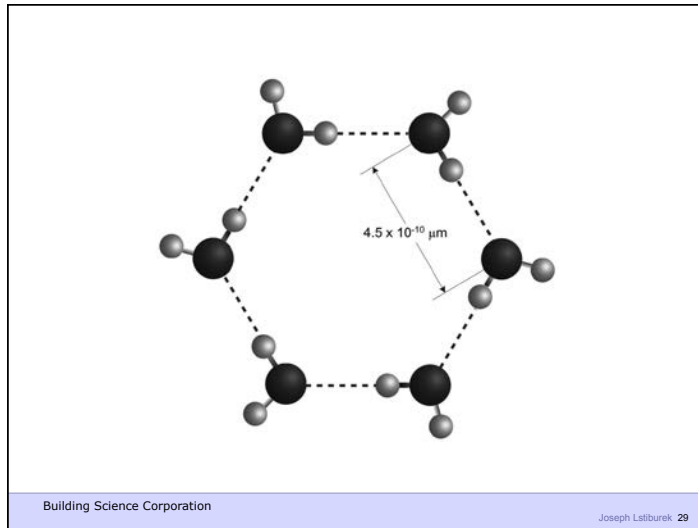

Damage Functions

Building Science Corporation Joseph Lstiburek 30

Damage Functions  
Water  
Heat  
Ultra Violet Radiation

Building Science Corporation Joseph Lstiburek 31

Damage Functions  
Water  
Heat  
Ultra Violet Radiation  
Oxidization (Ozone)  
Fatigue (Creep)

Building Science Corporation Joseph Lstiburek 32



The Three Biggest Problems In Buildings Are  
Water, Water and Water...

Building Science Corporation Joseph Lstiburek 33

80 Percent of all Construction Problems are  
Related to Water

Building Science Corporation Joseph Lstiburek 34

Heat  
Air  
Moisture

Building Science Corporation Joseph Lstiburek 35

HAM

Building Science Corporation Joseph Lstiburek 36

Hygrothermal Analysis

Building Science Corporation Joseph Lstiburek 37

Water Control Layer  
Air Control Layer  
Vapor Control Layer  
Thermal Control Layer

Building Science Corporation Joseph Lstiburek 38

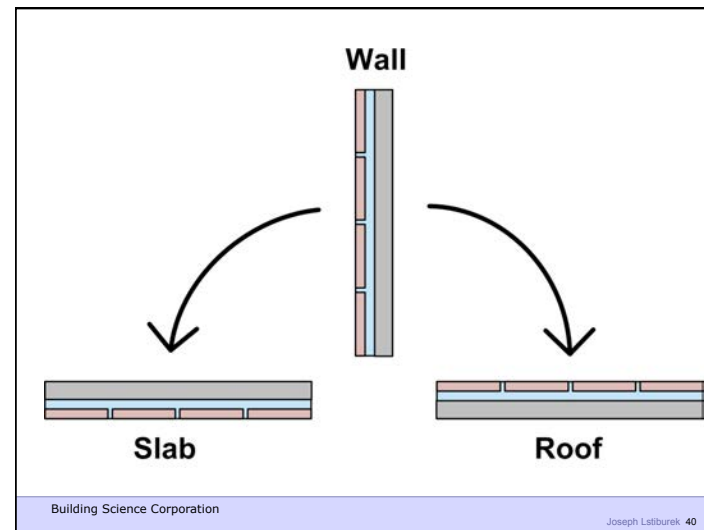
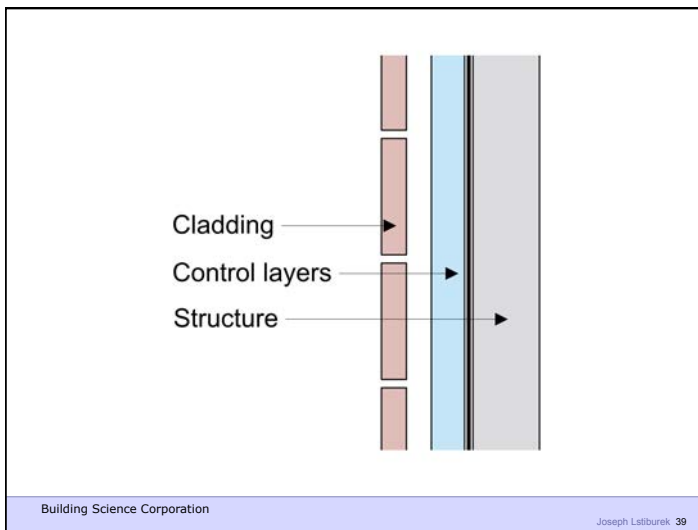

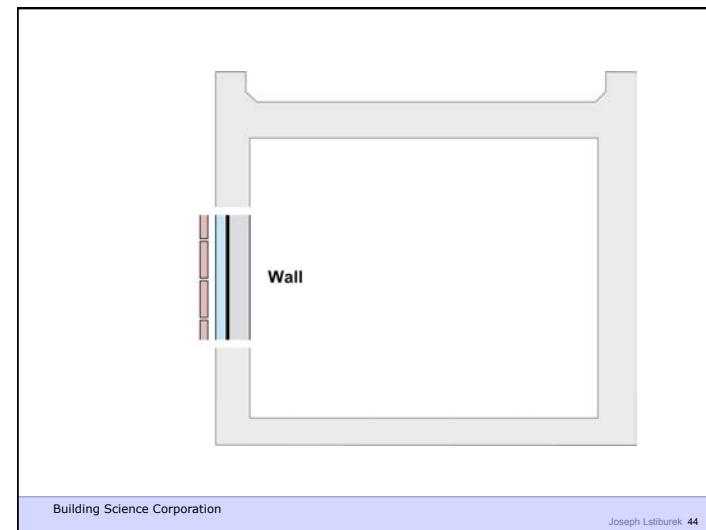
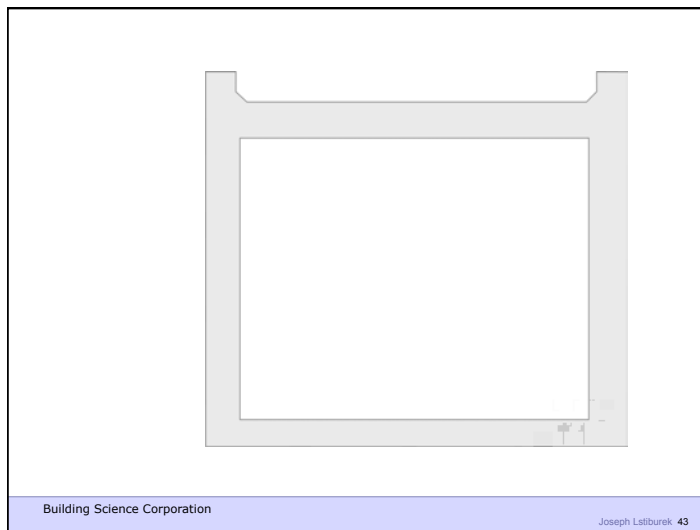
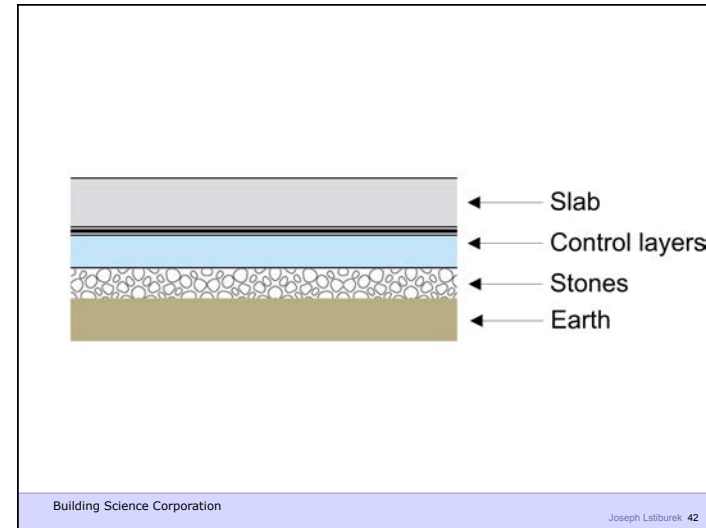
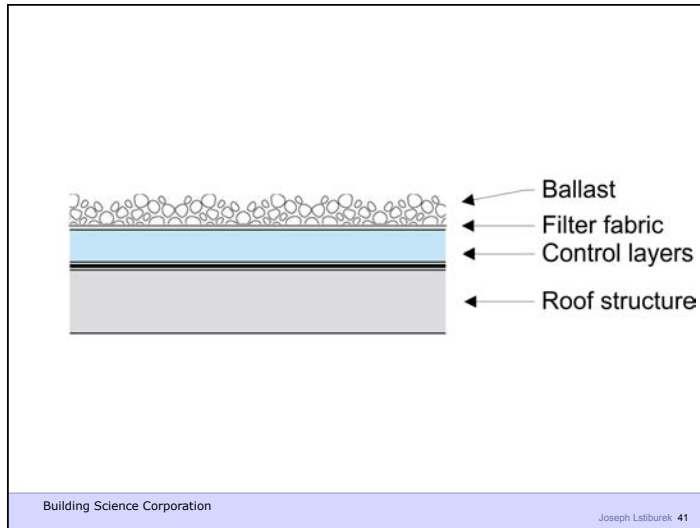

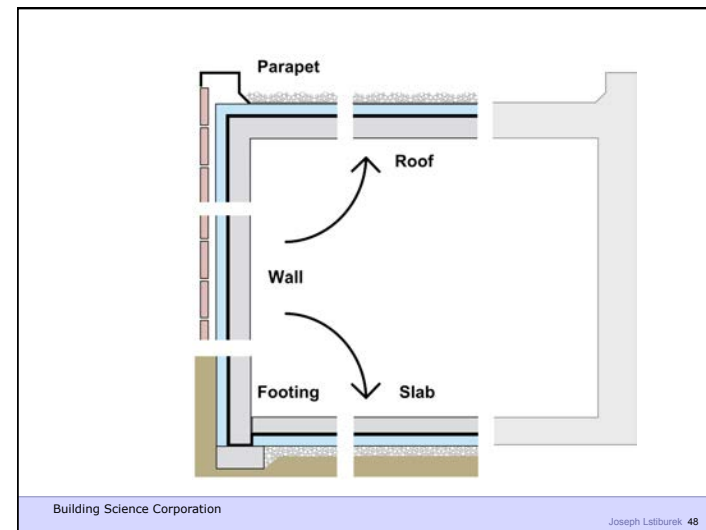
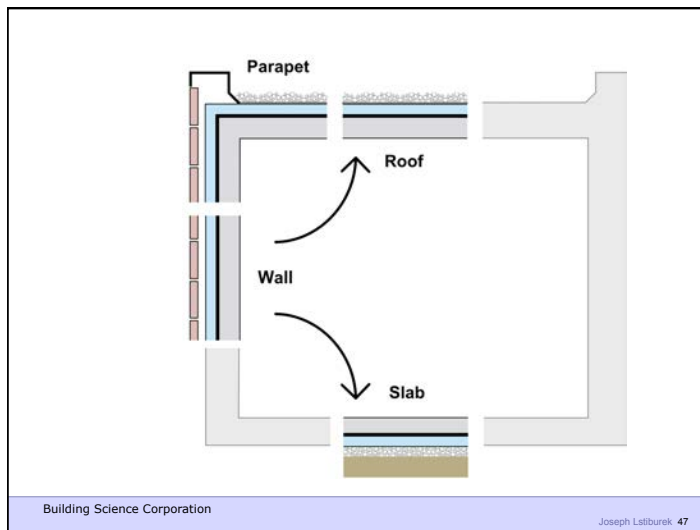
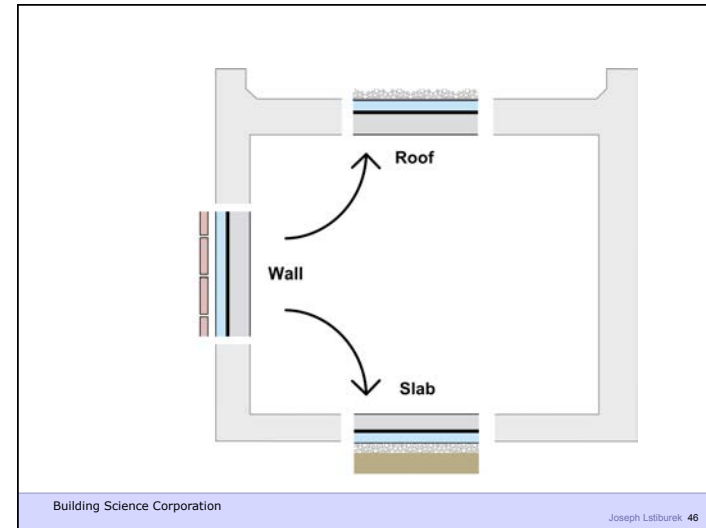
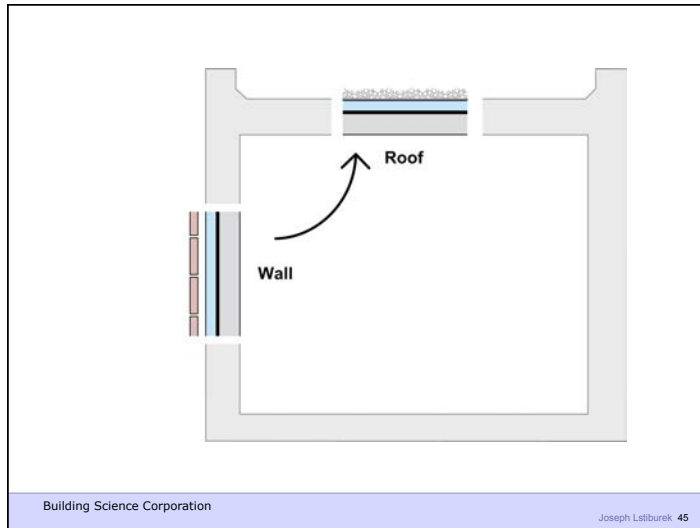

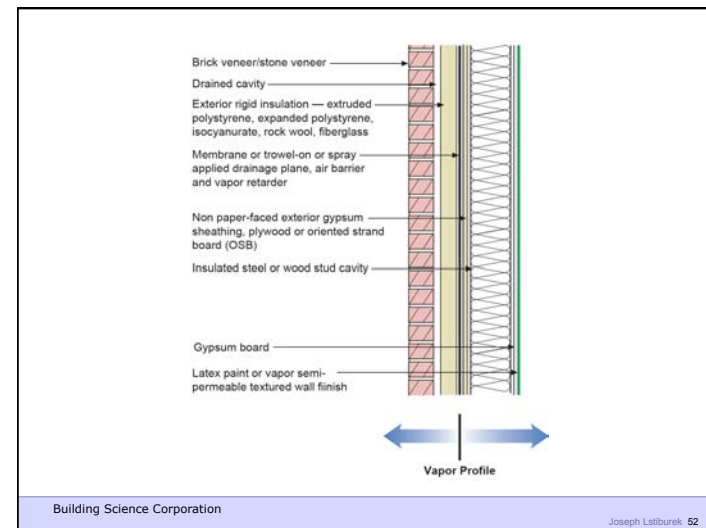
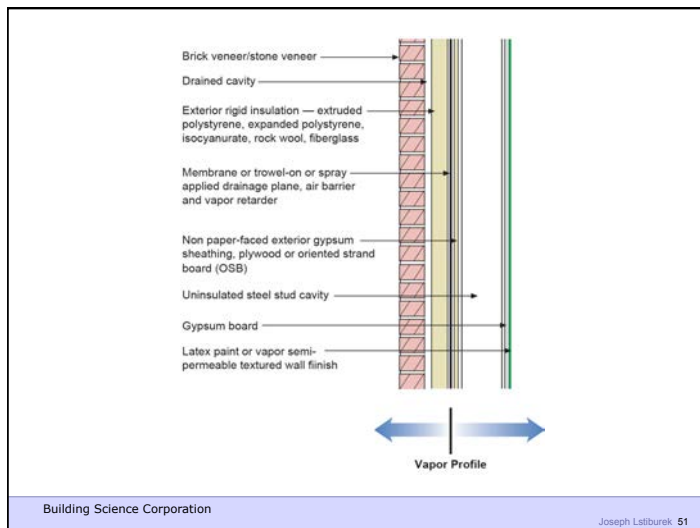
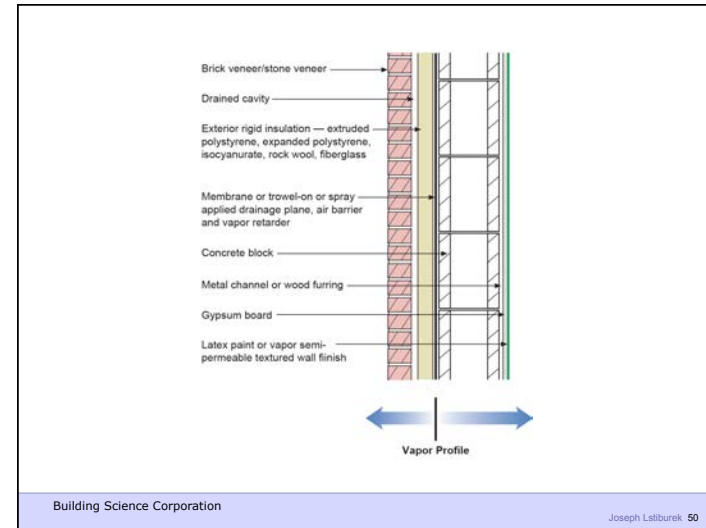
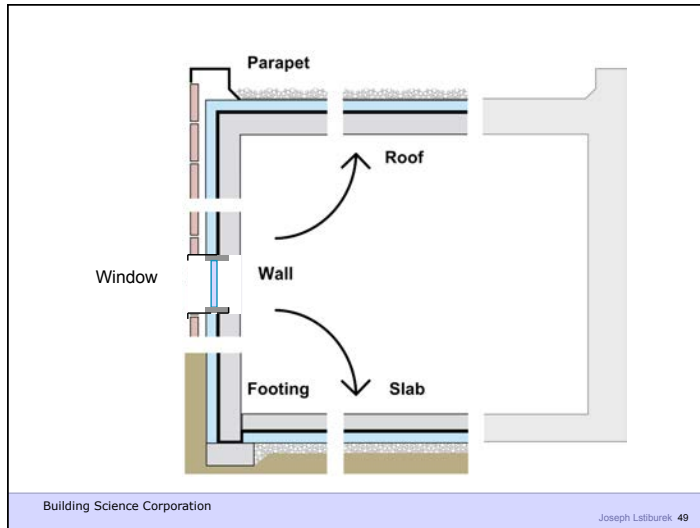

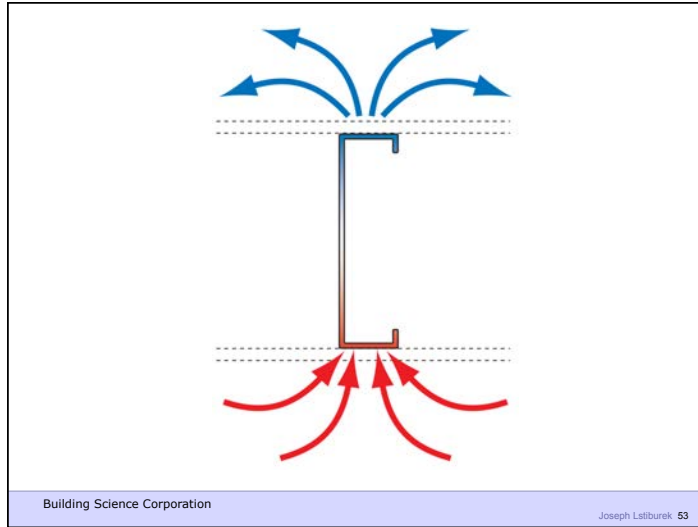

### Commercial Enclosure: Simple Layers

- Structure
- Rain/Air/Vapor
- Insulation
- Finish

Building Science Corporation  
Joseph Lstiburek 55

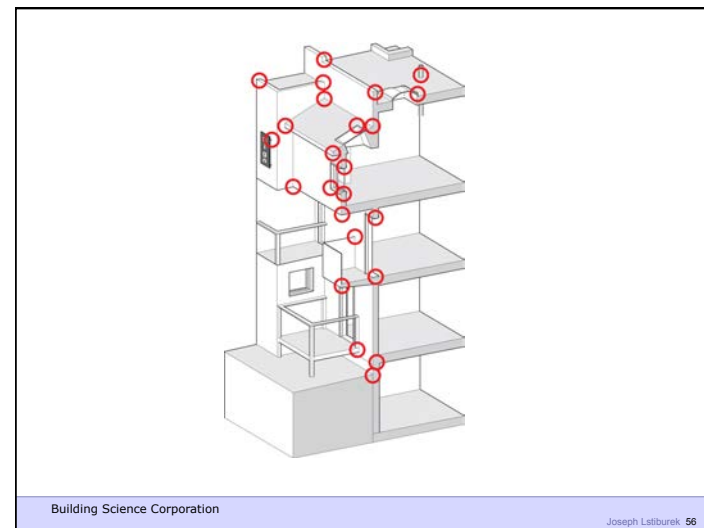

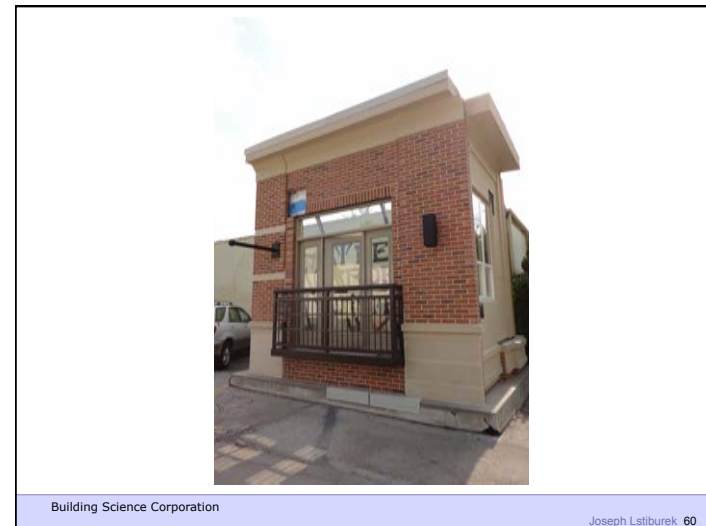

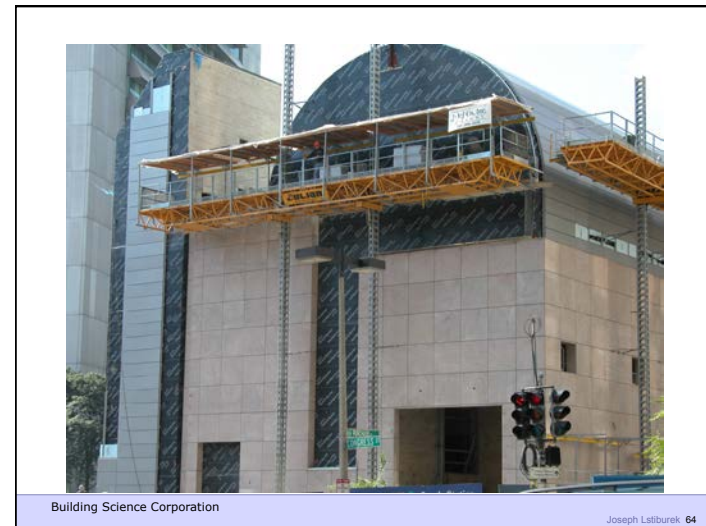
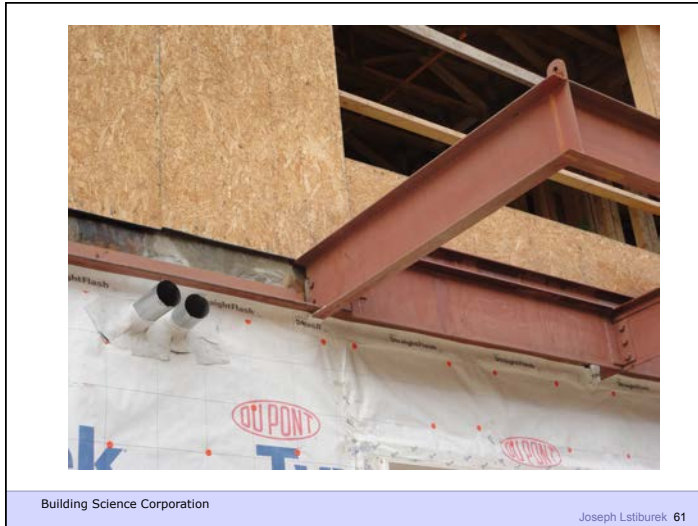



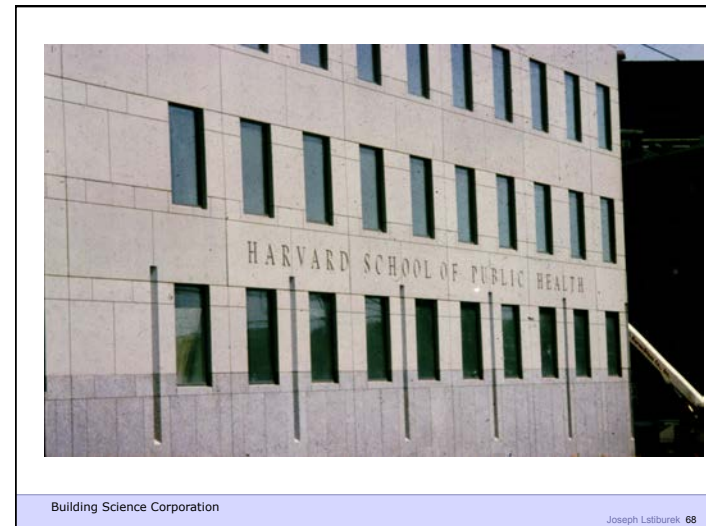
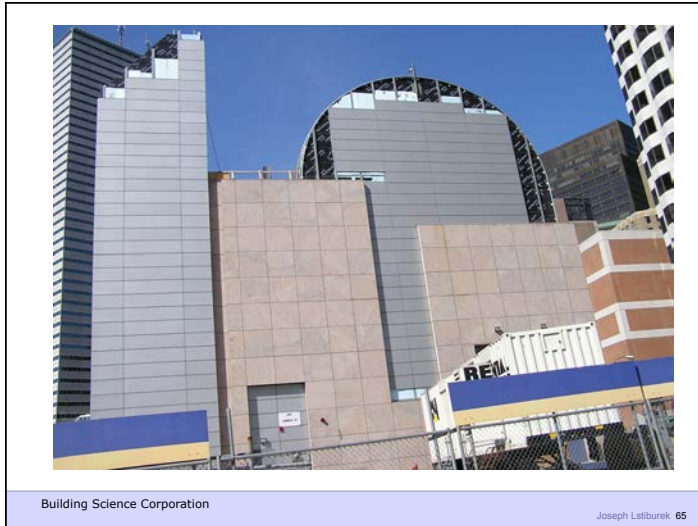

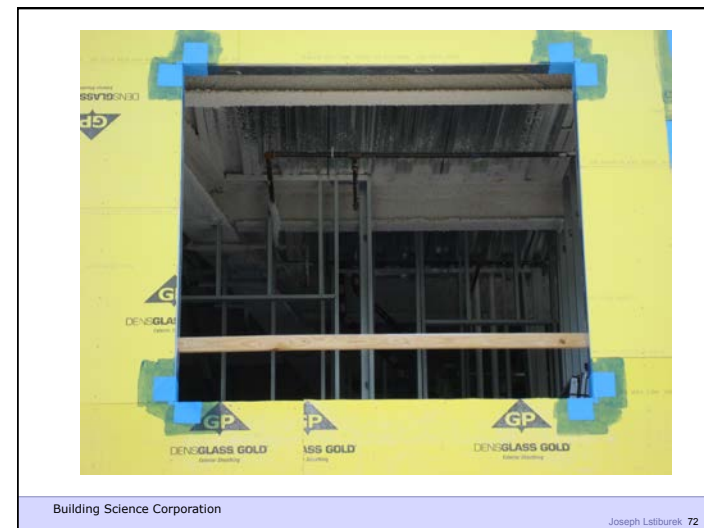
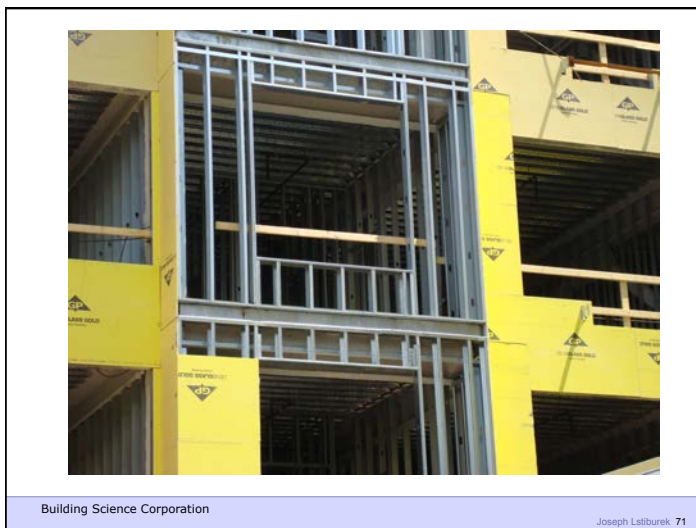

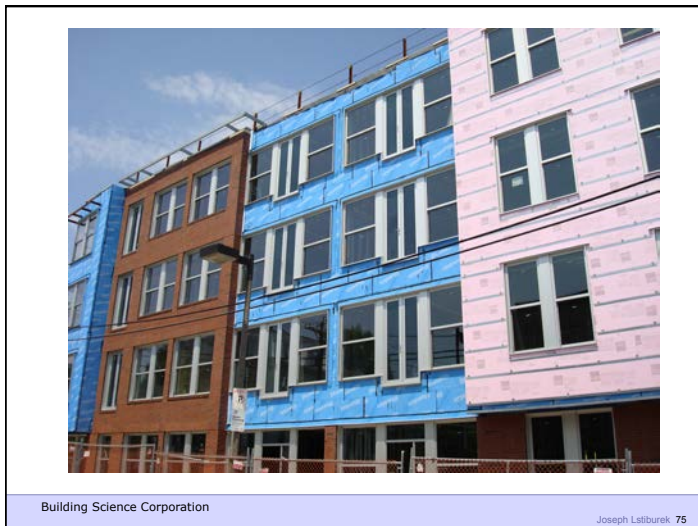
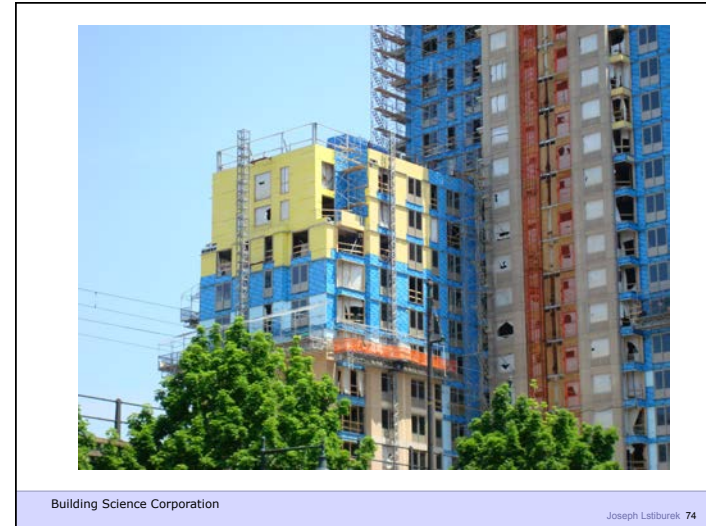



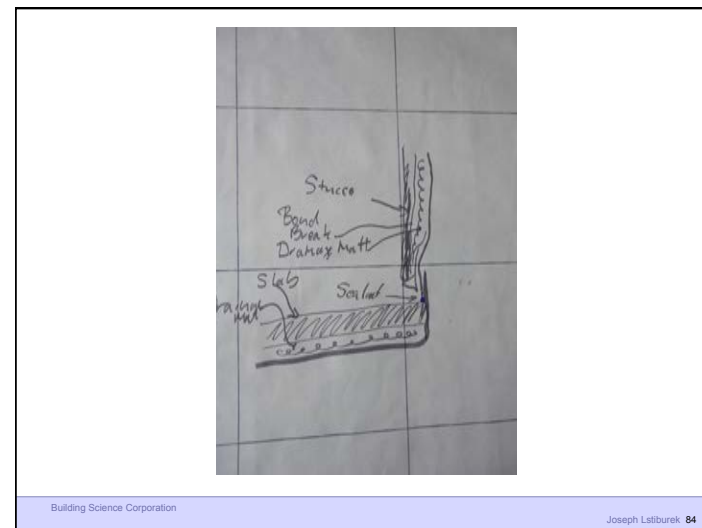

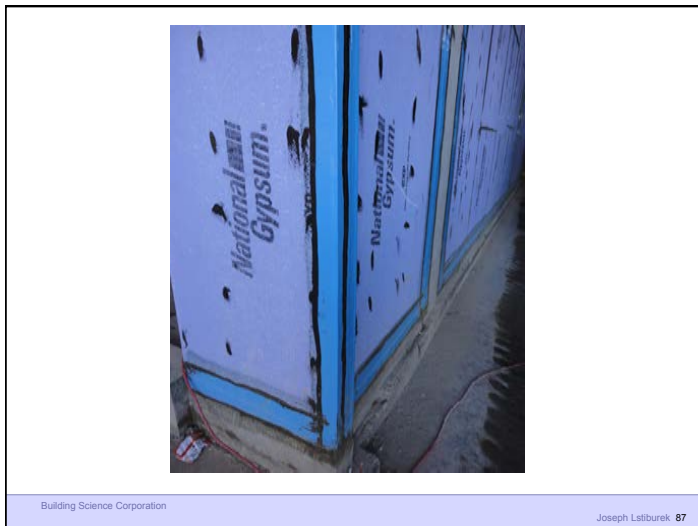



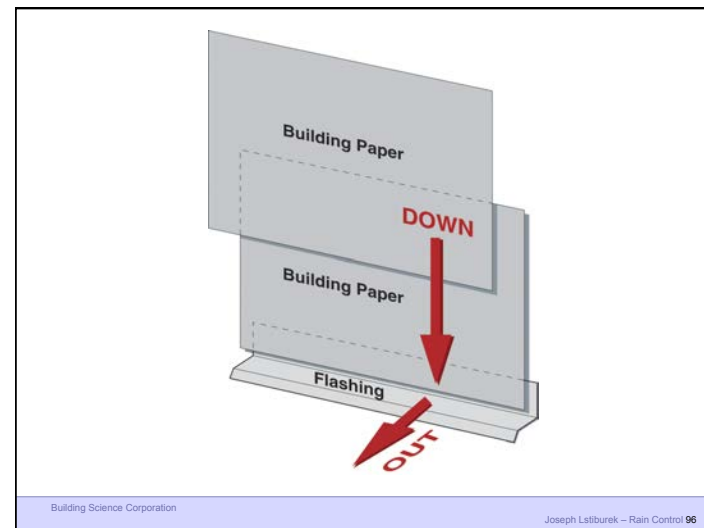
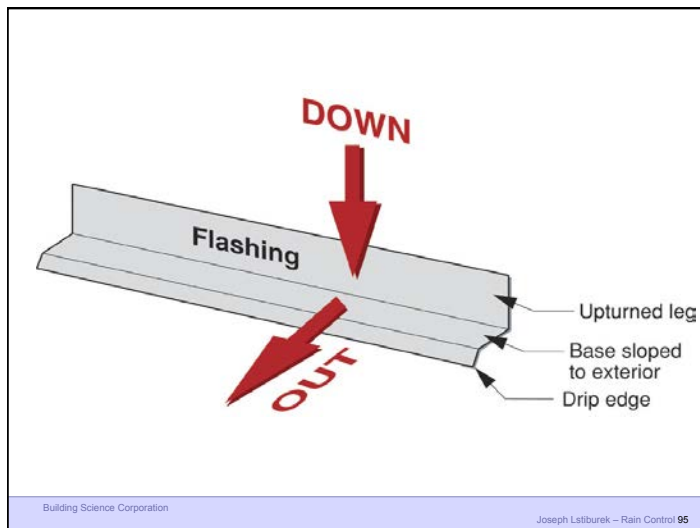
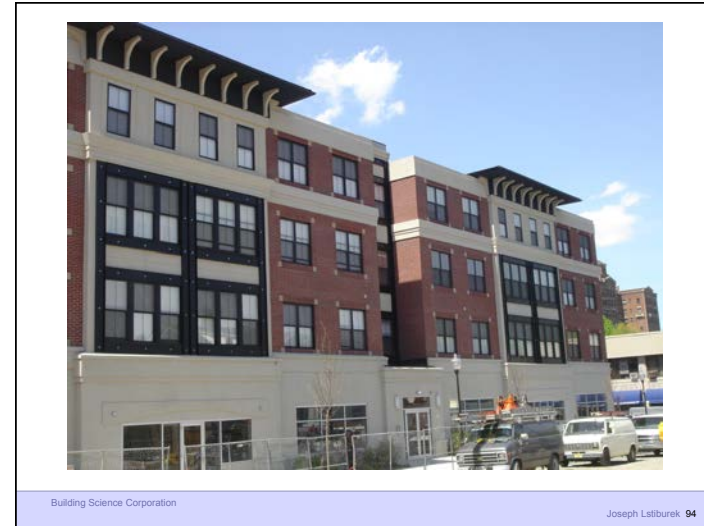
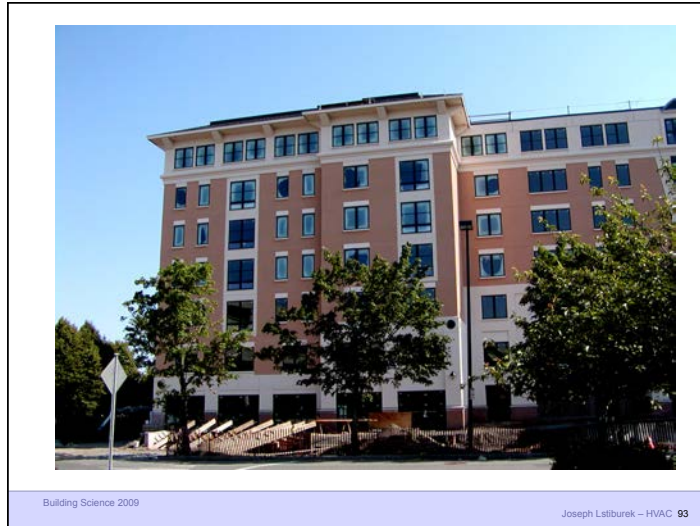



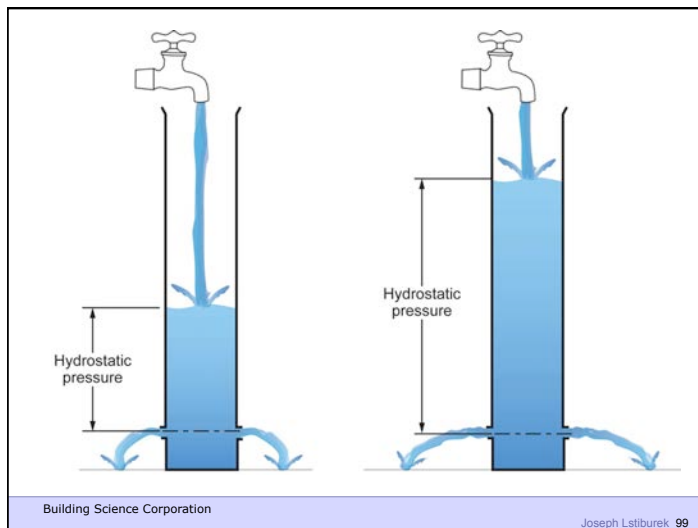

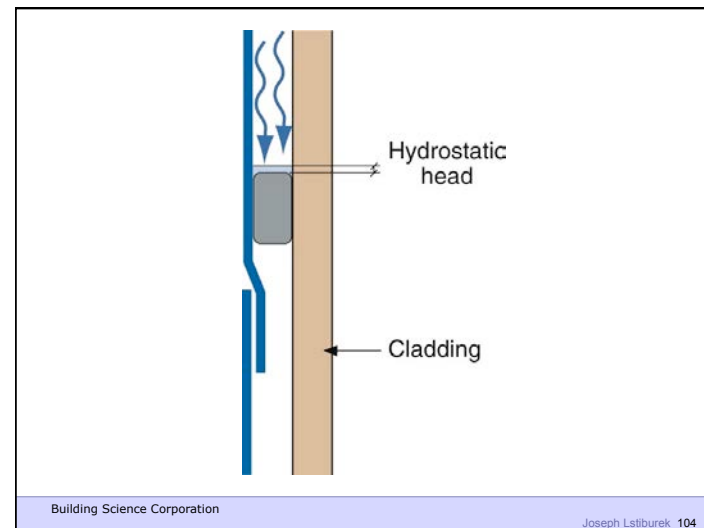
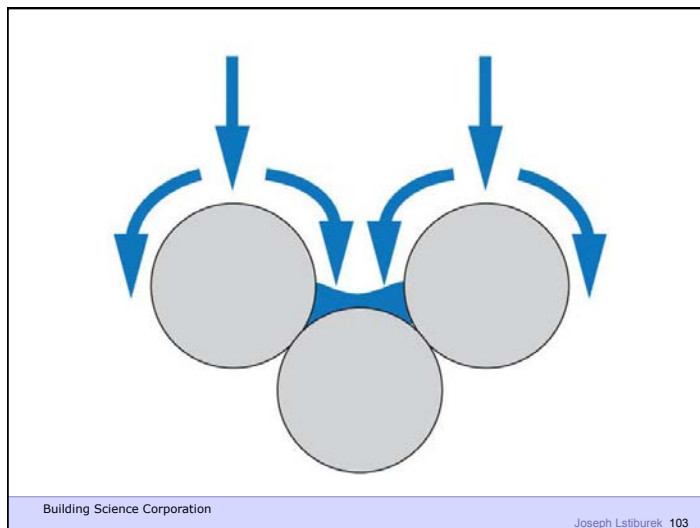
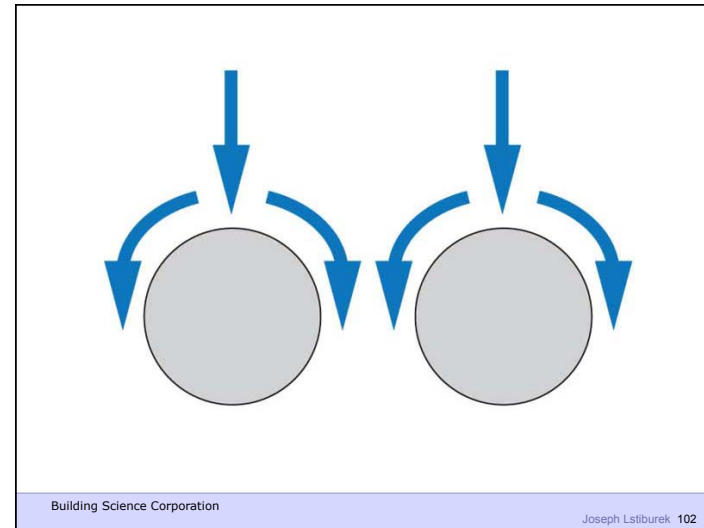
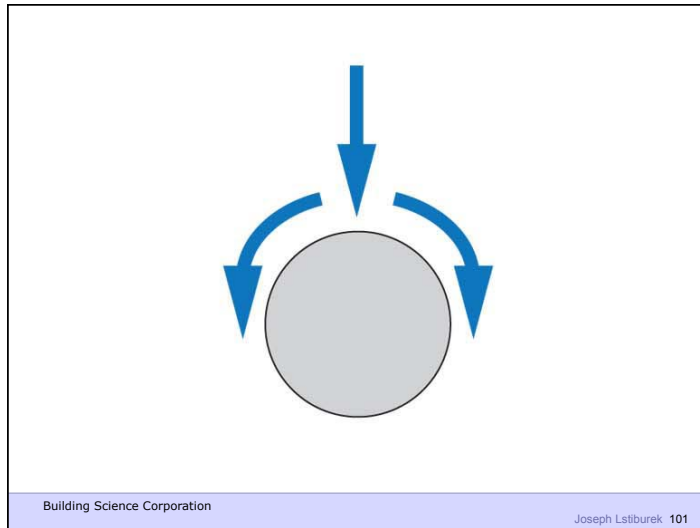

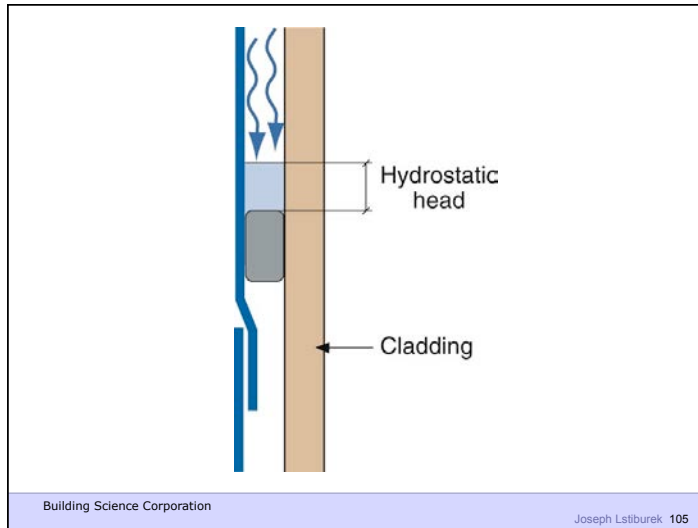

Building Science Corporation

Joseph Lstiburek 105

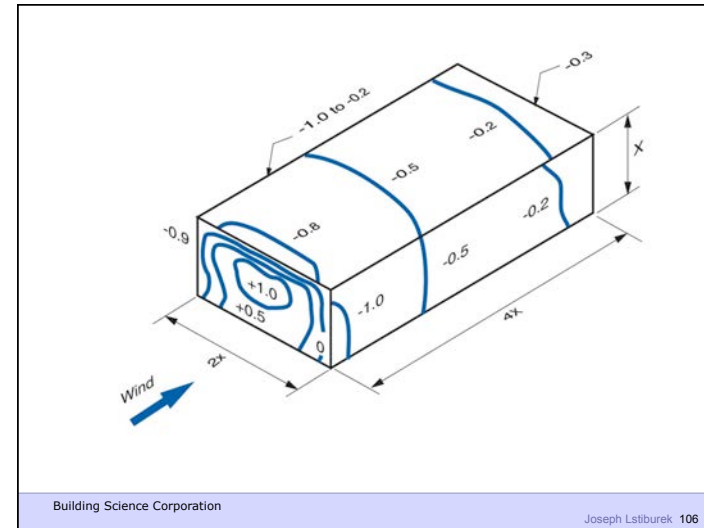

Building Science Corporation

Joseph Lstiburek 106

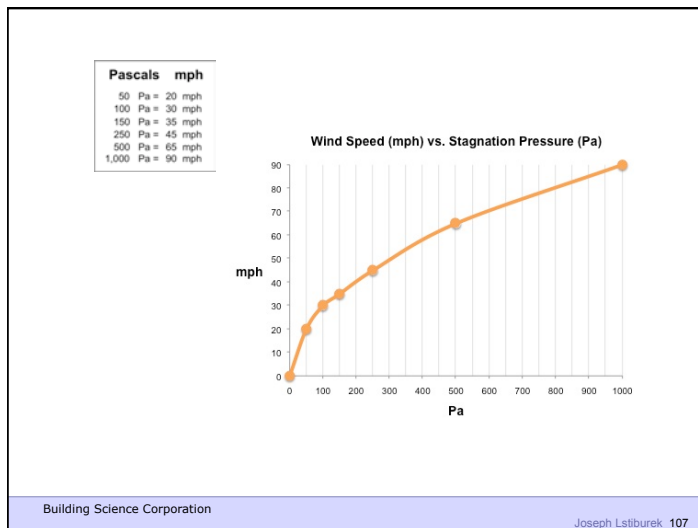

Building Science Corporation

Joseph Lstiburek 107



Building Science Corporation

Joseph Lstiburek 108

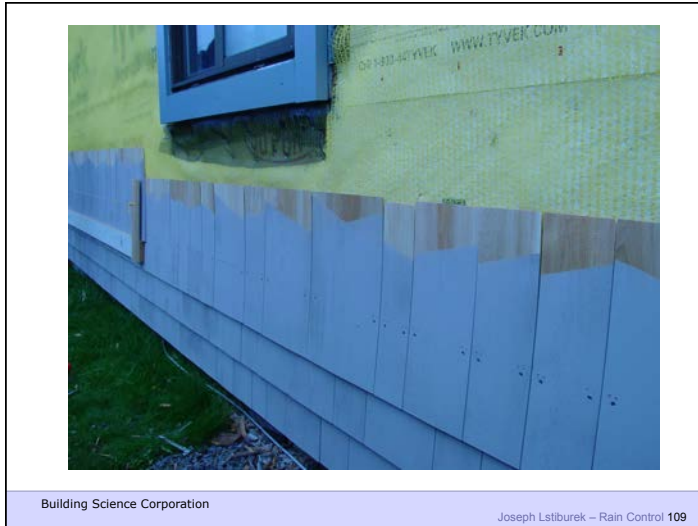

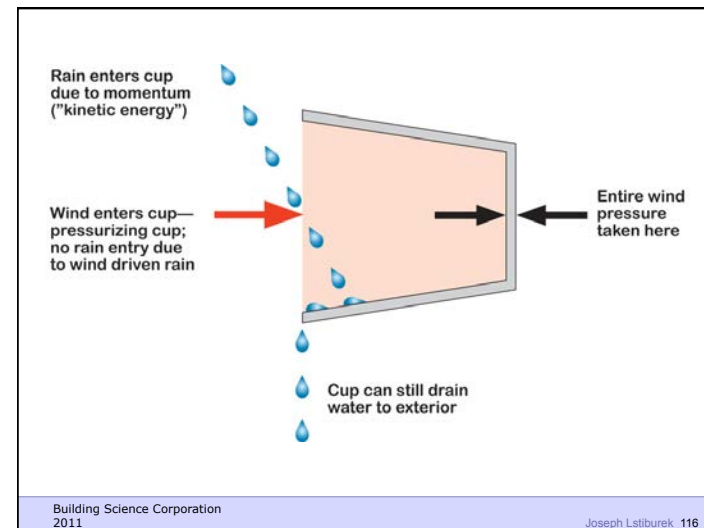
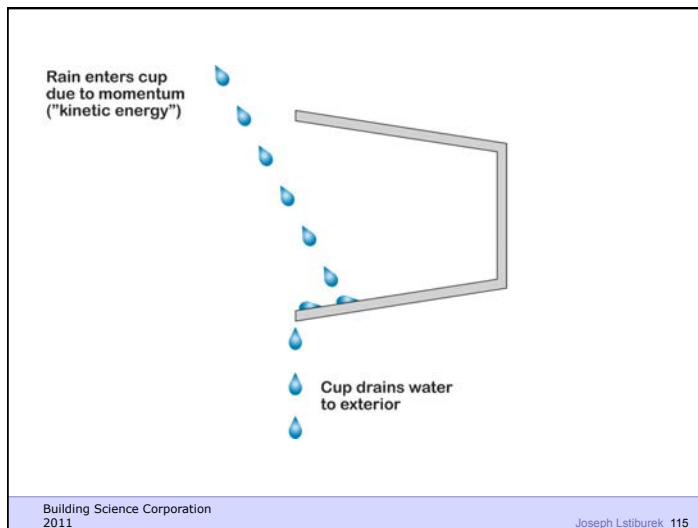
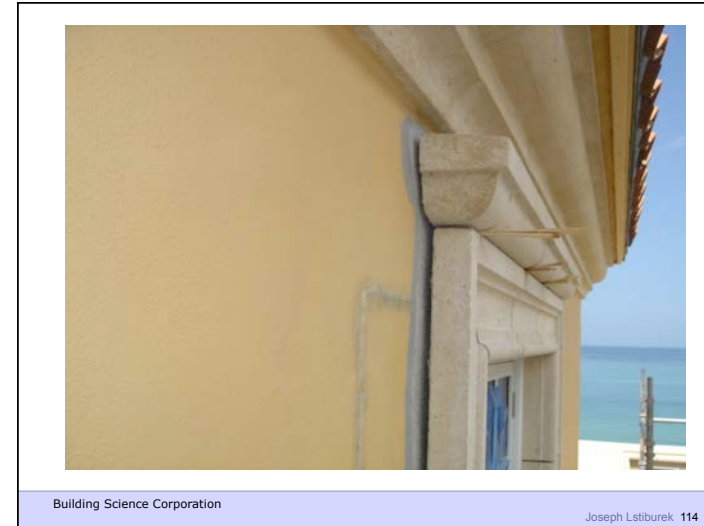
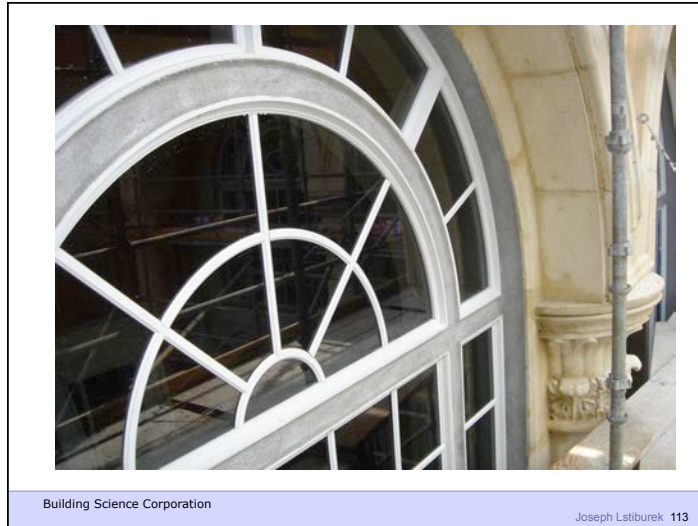

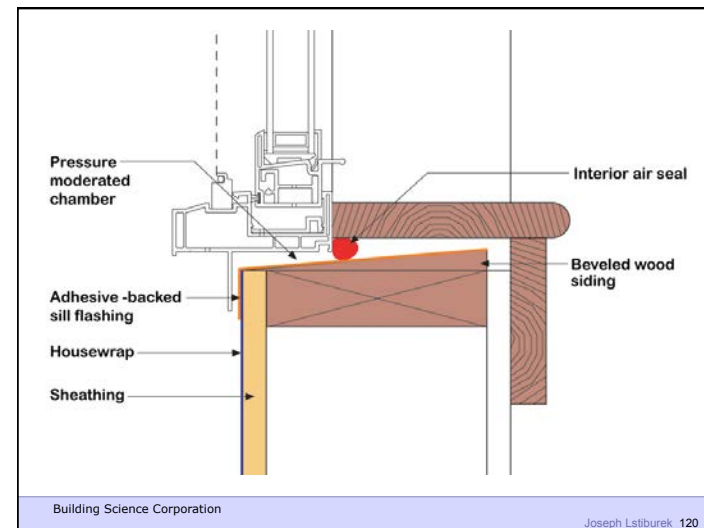
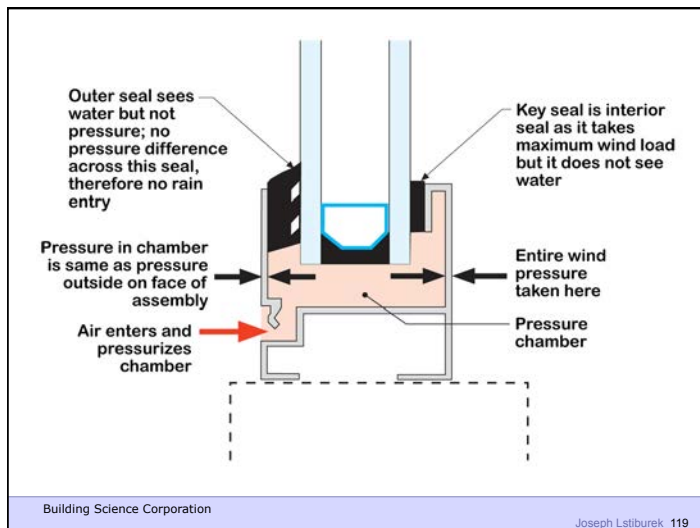
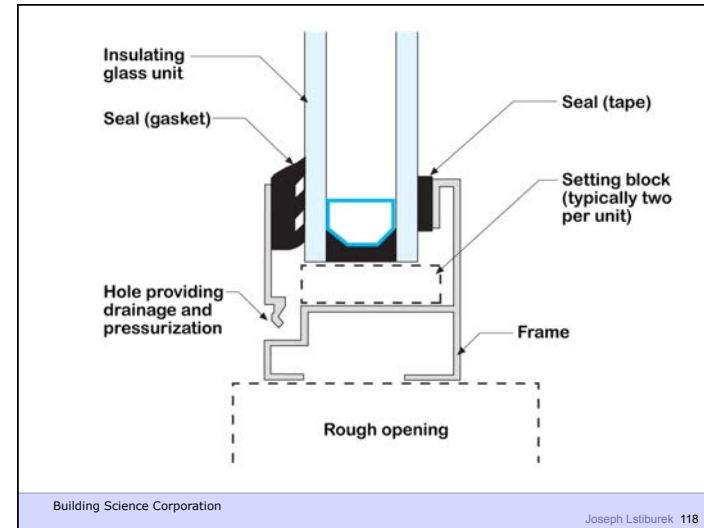
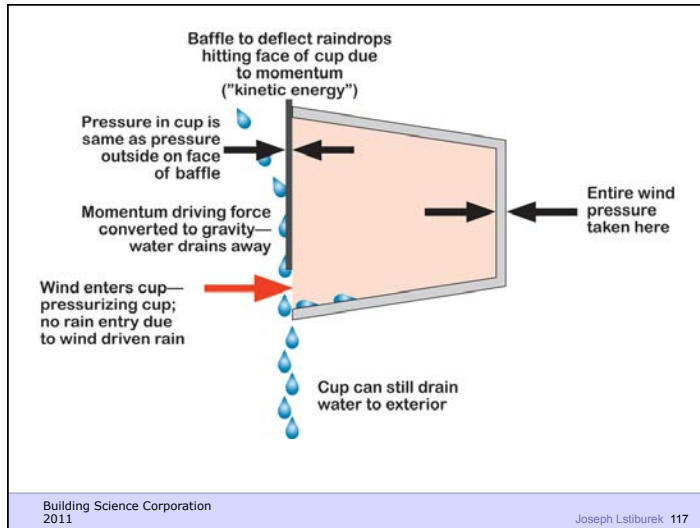

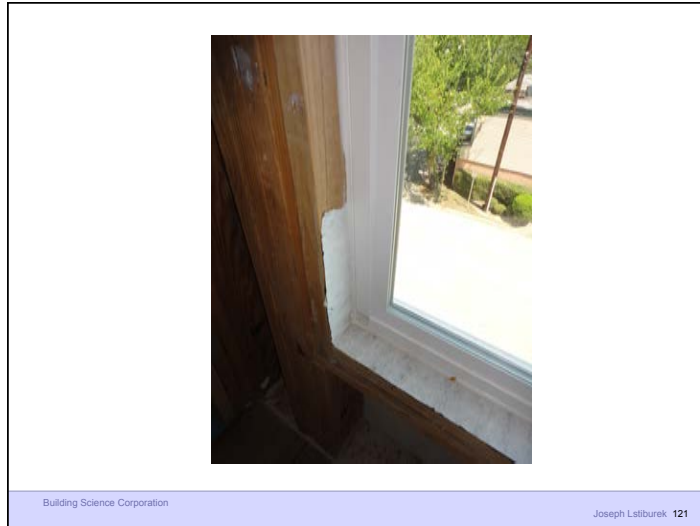

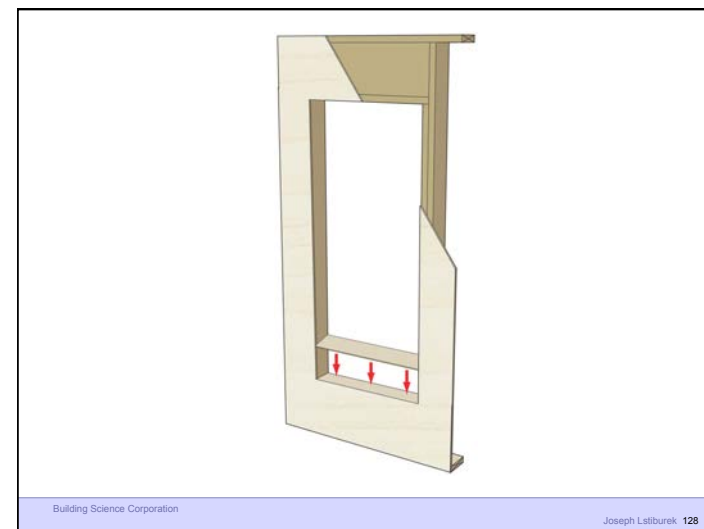
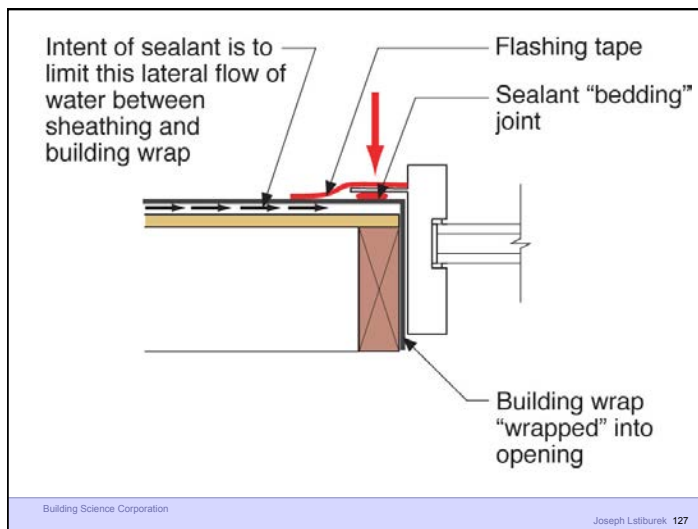



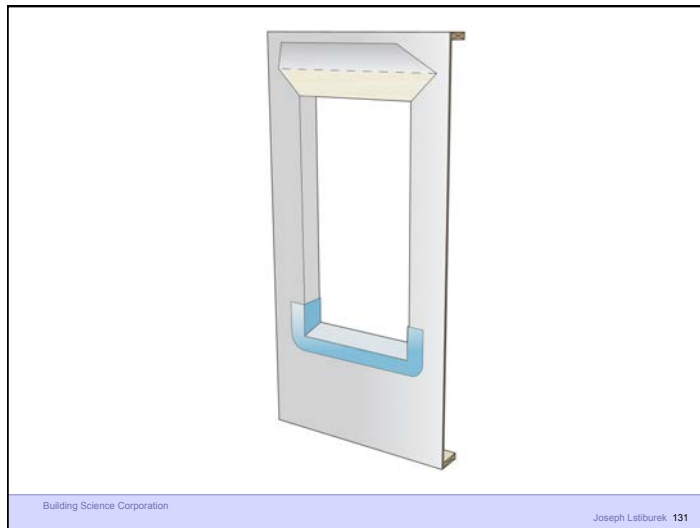
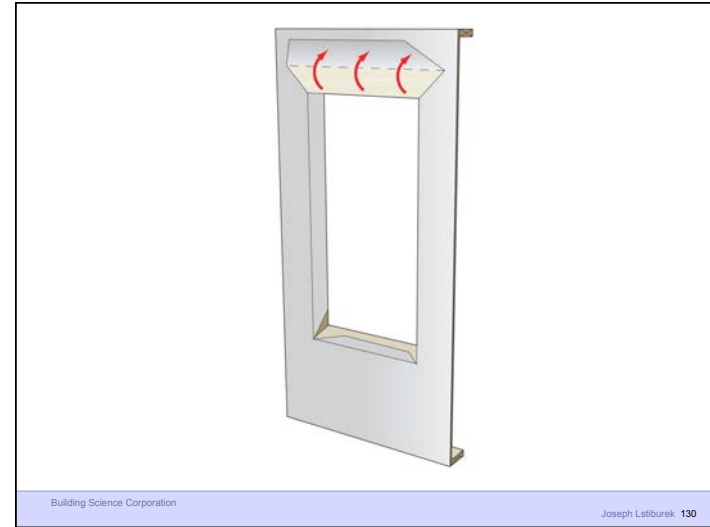
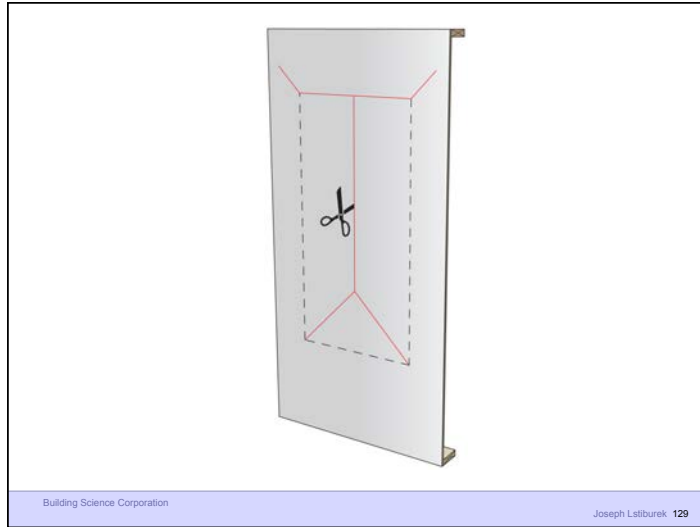

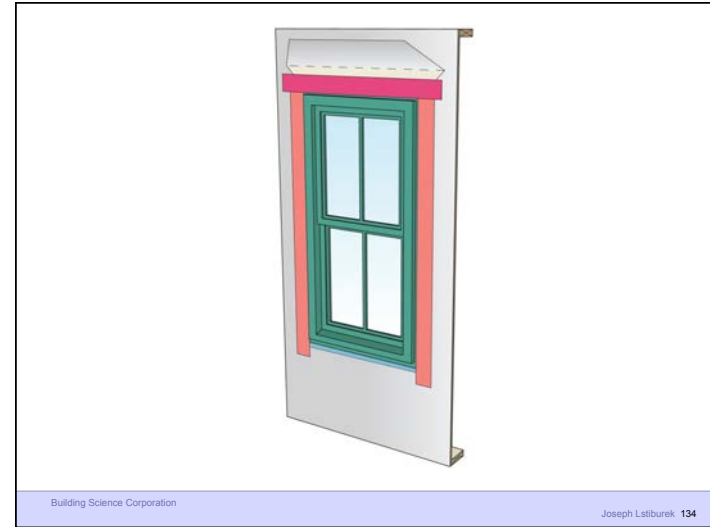
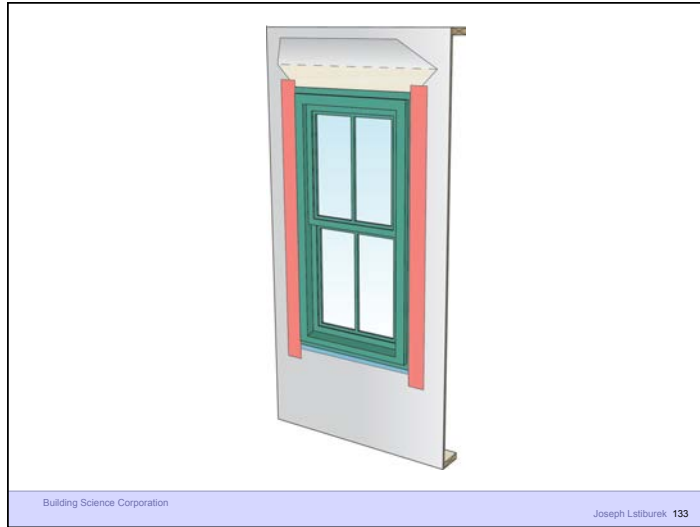

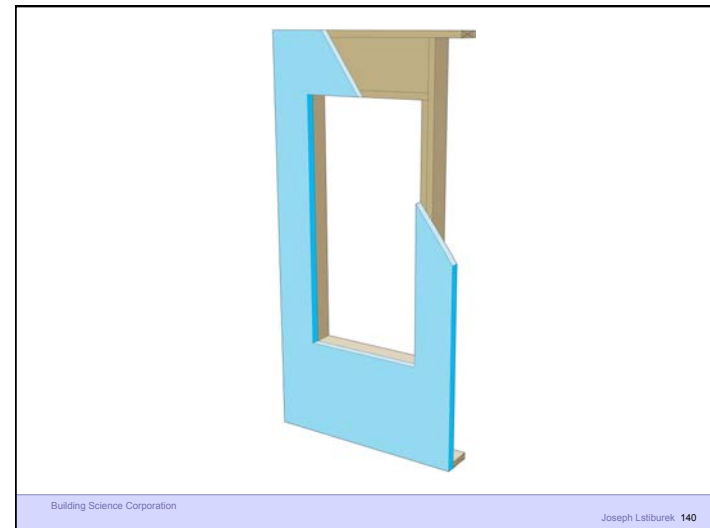
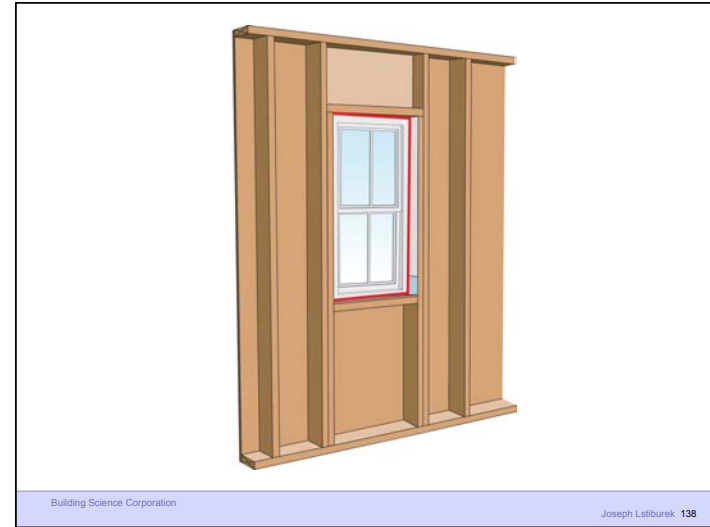
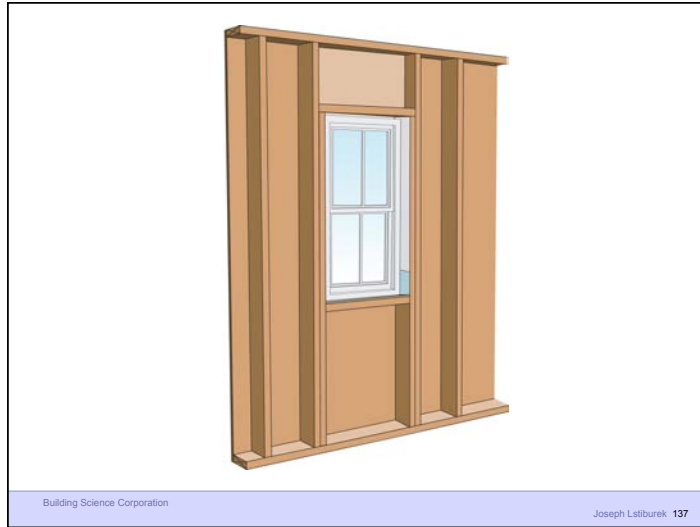

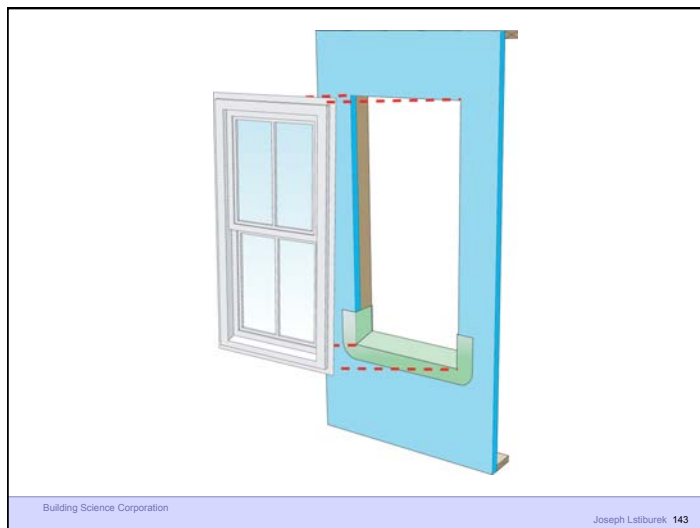
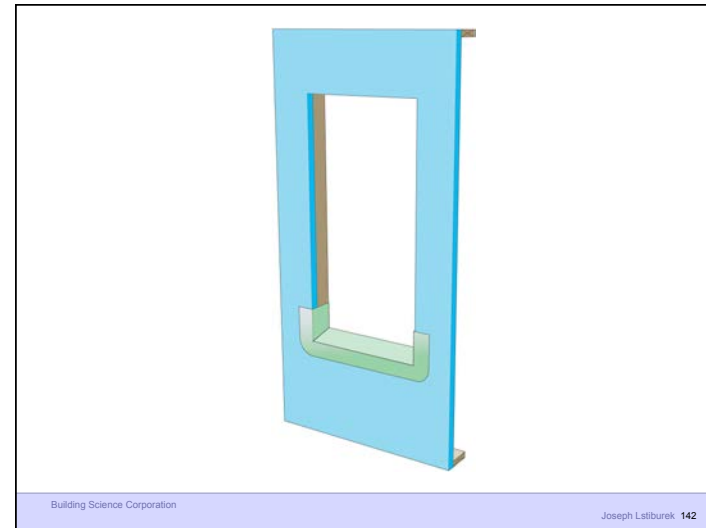
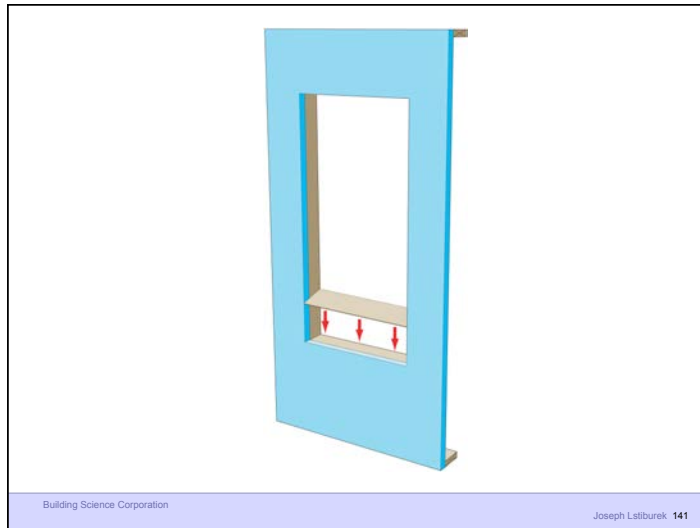

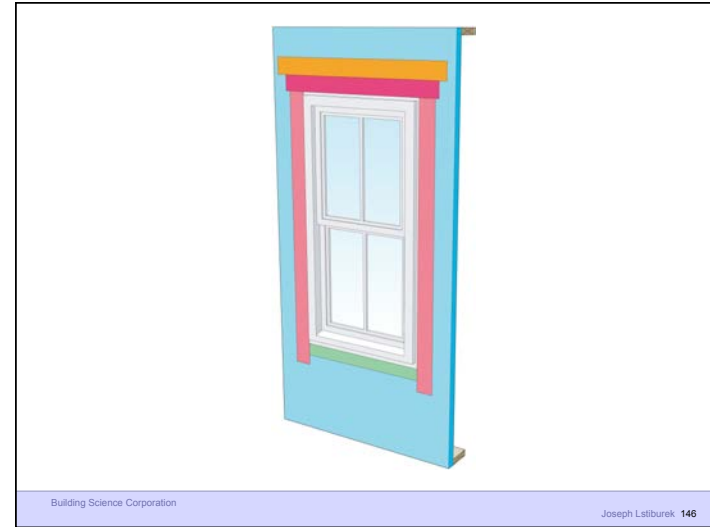
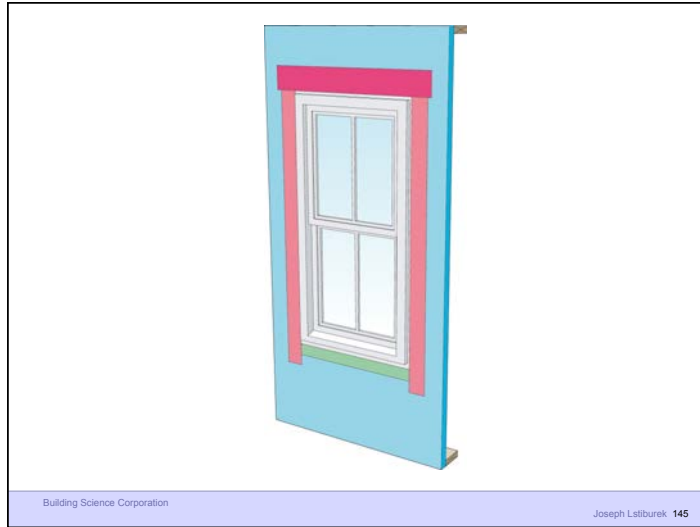

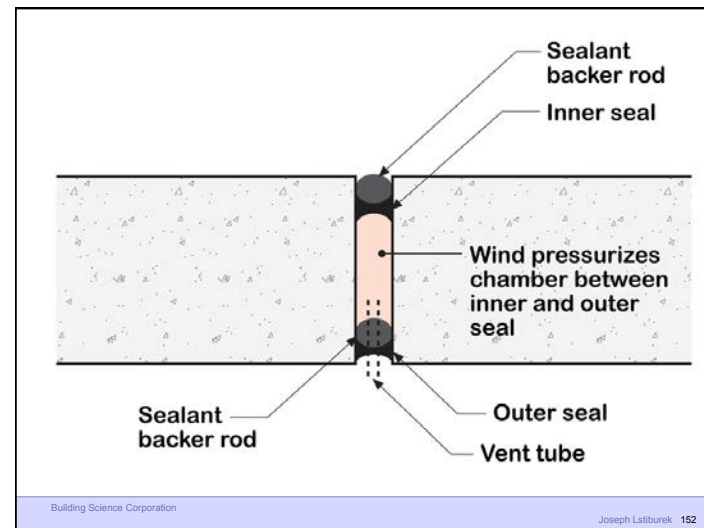

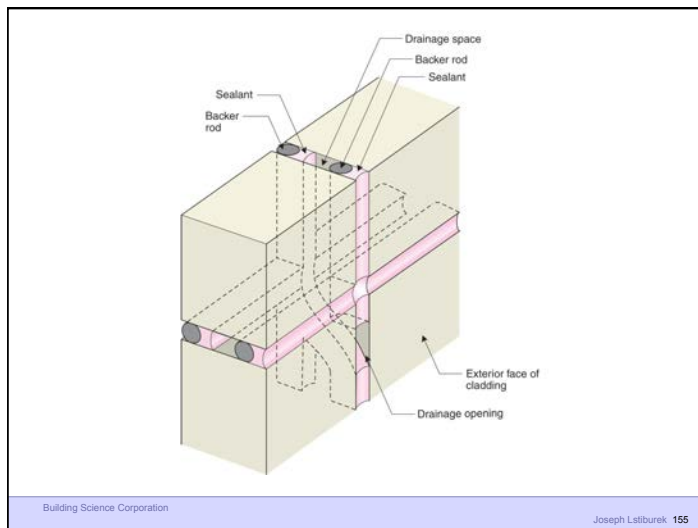
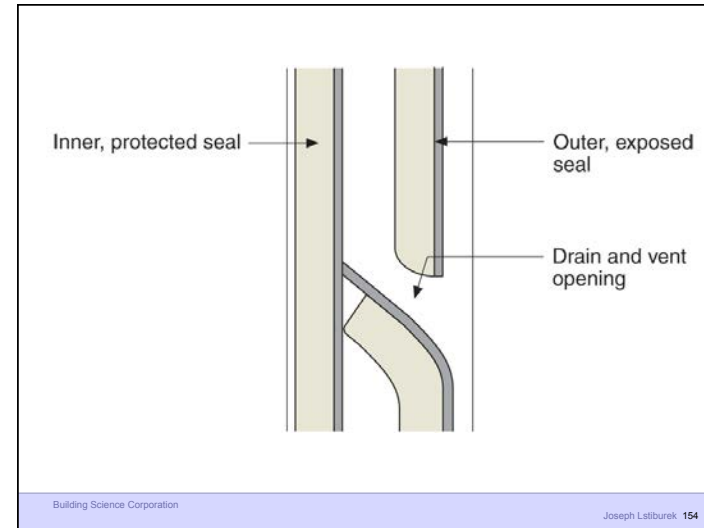
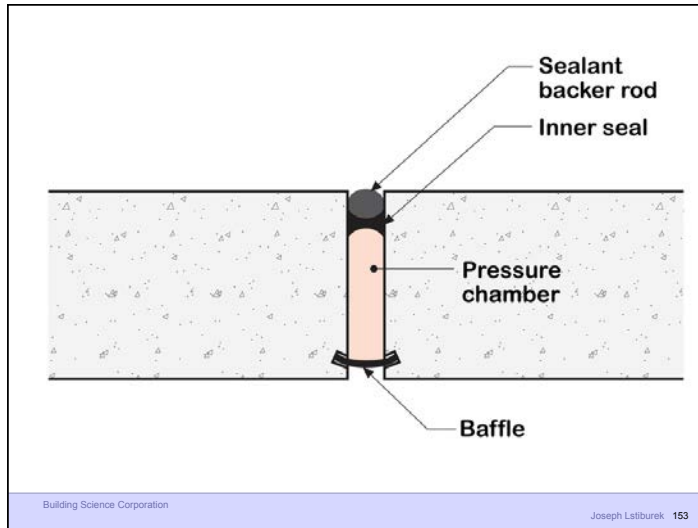

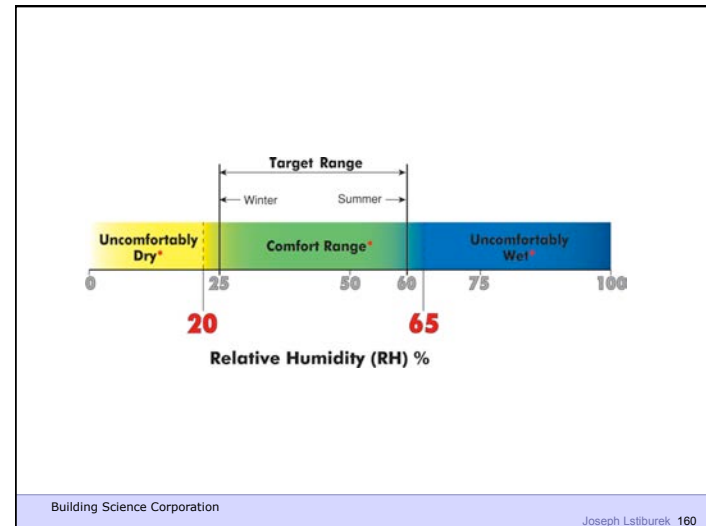
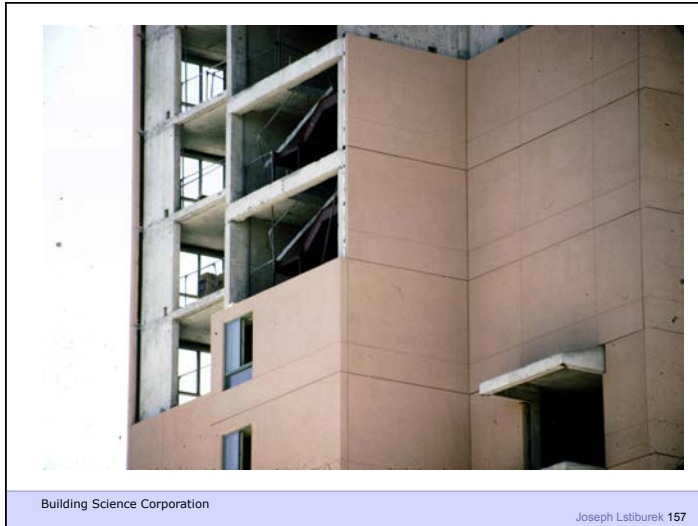



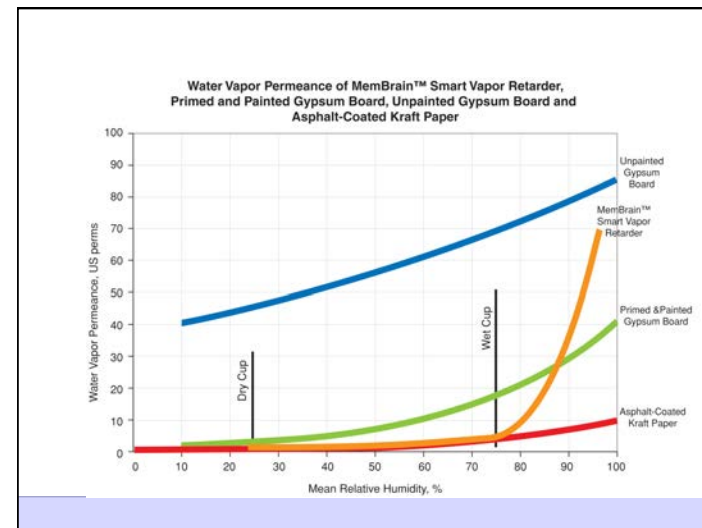
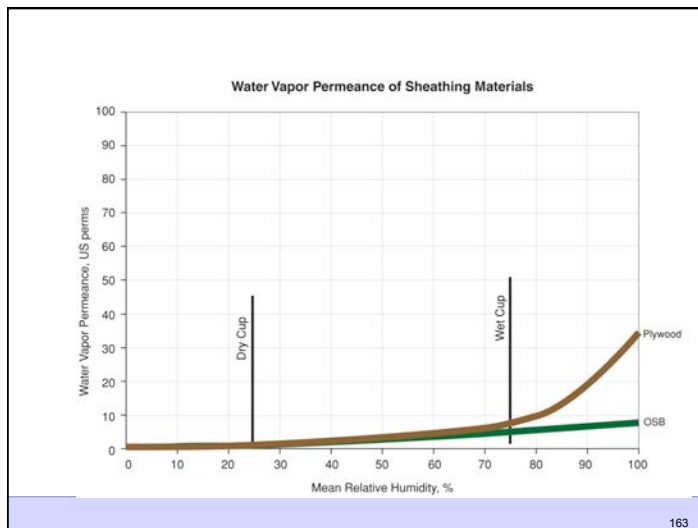
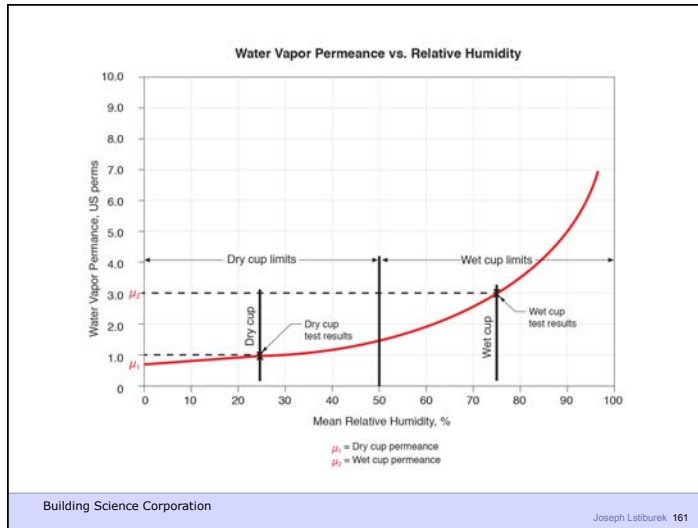

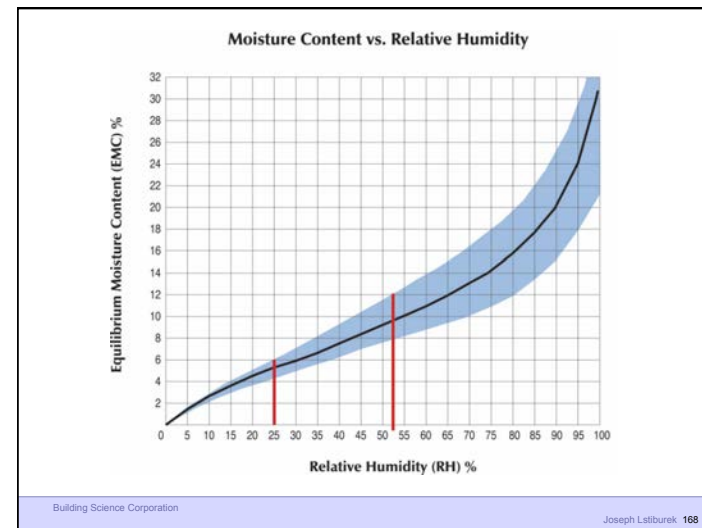
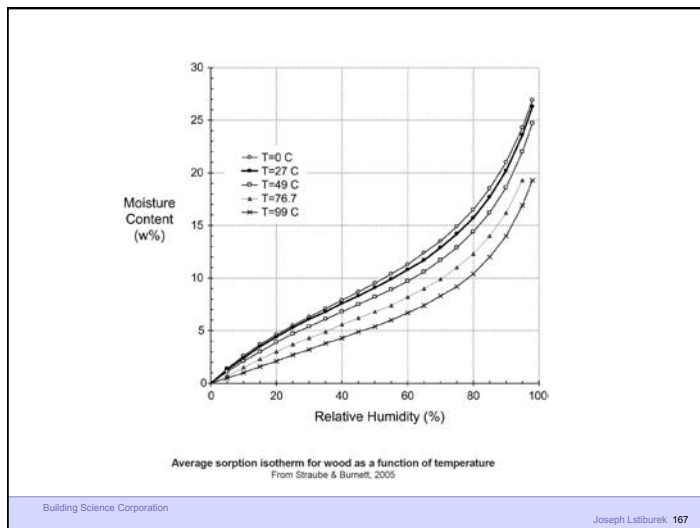
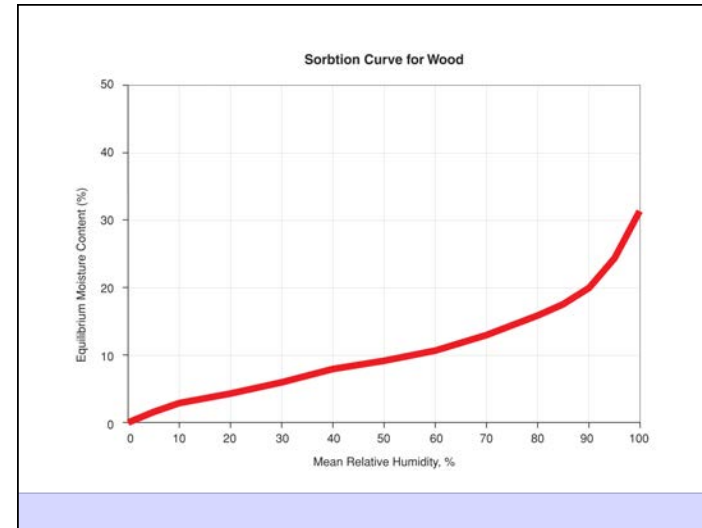
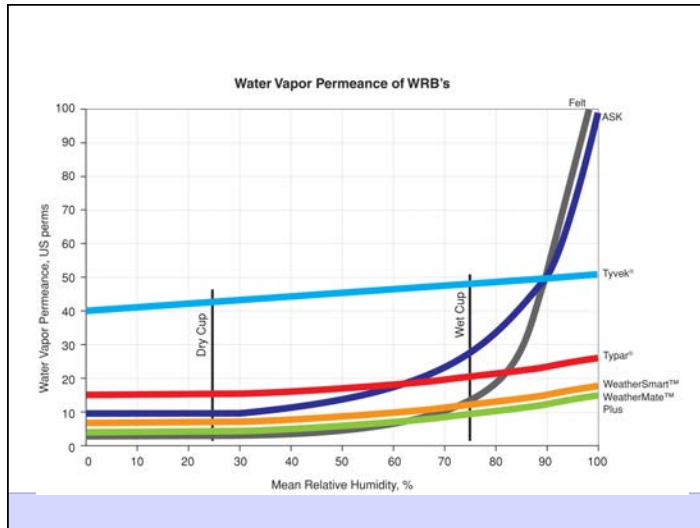

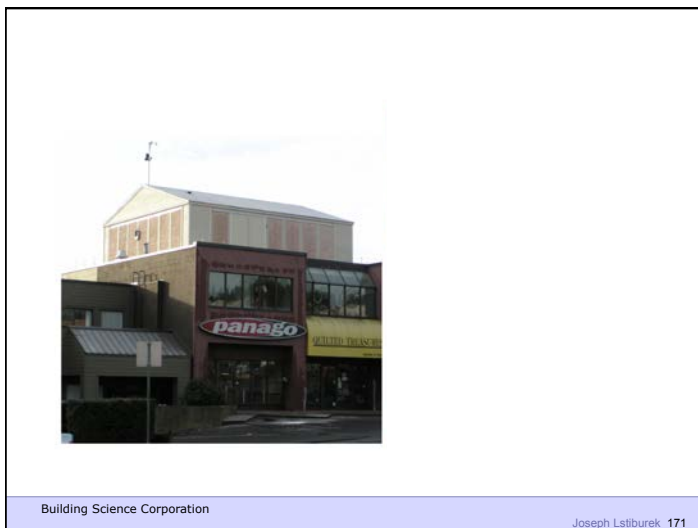
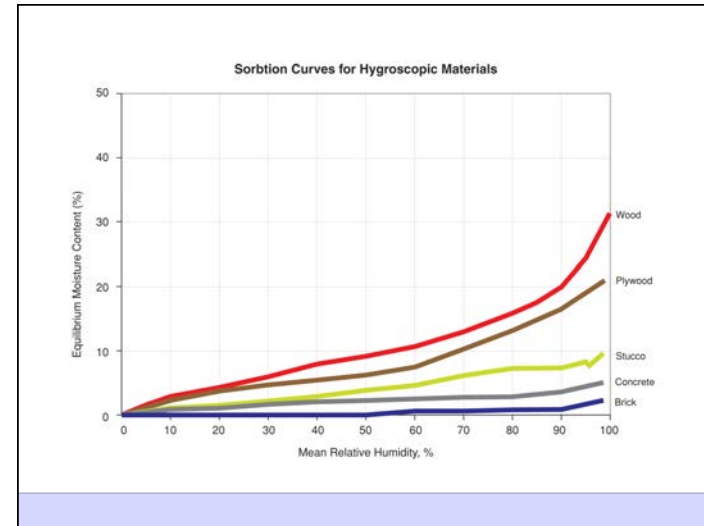

Building Science Corporation

Joseph Lstiburek 171

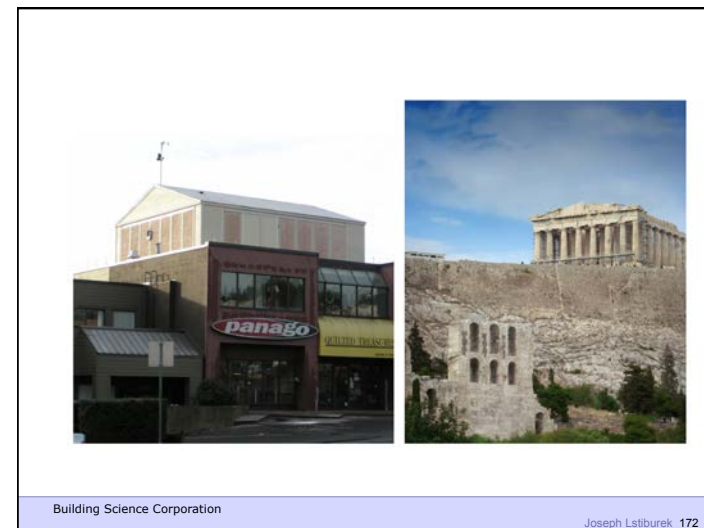

Building Science Corporation

Joseph Lstiburek 172



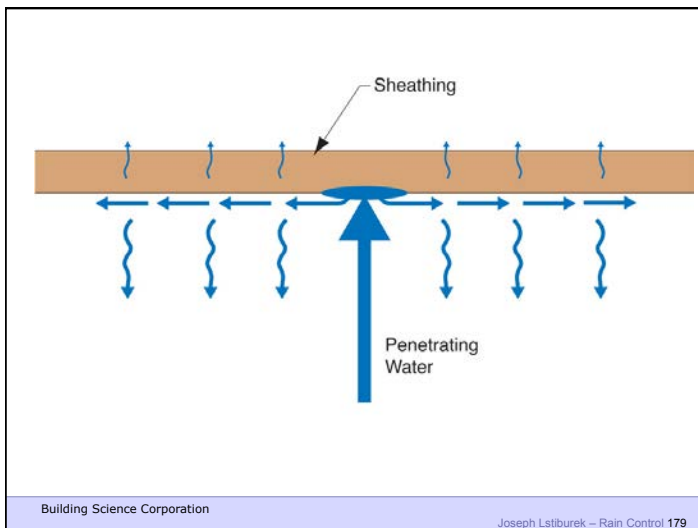
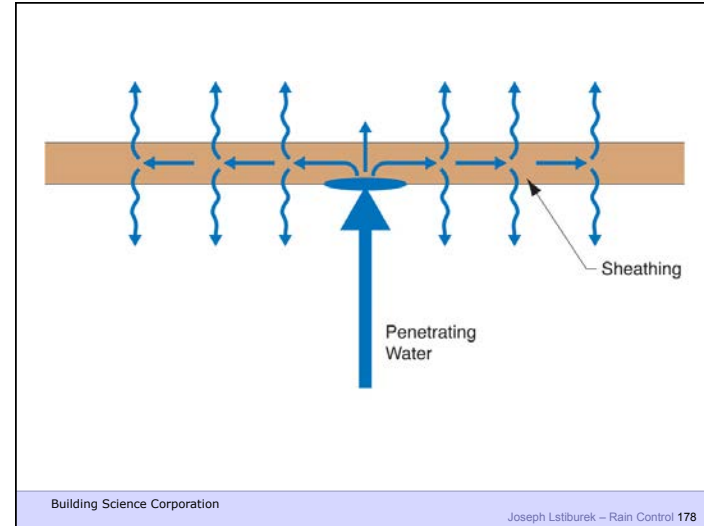

Rain Screen

Building Science Corporation Joseph Lstiburek 181

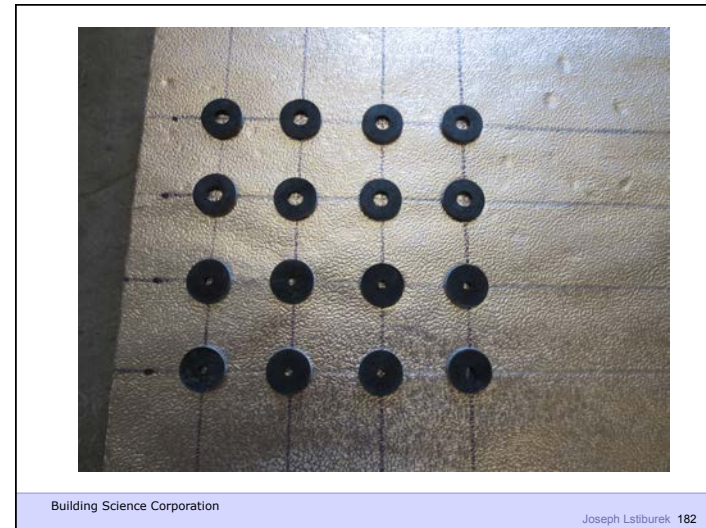

Beer Screen?

Building Science Corporation Joseph Lstiburek 183

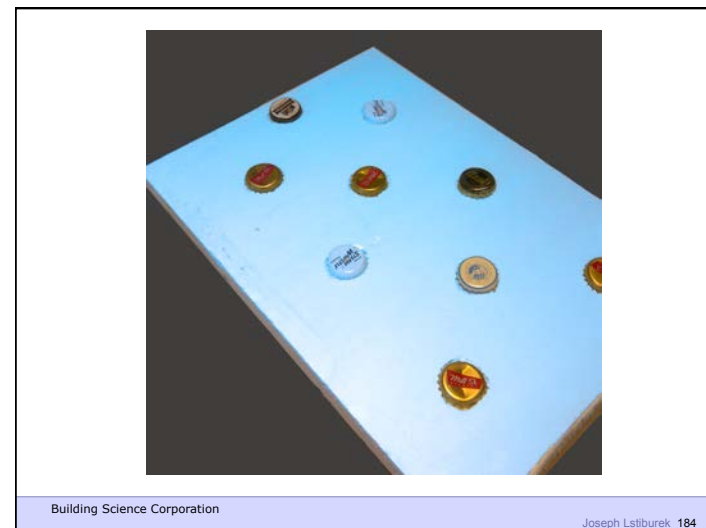

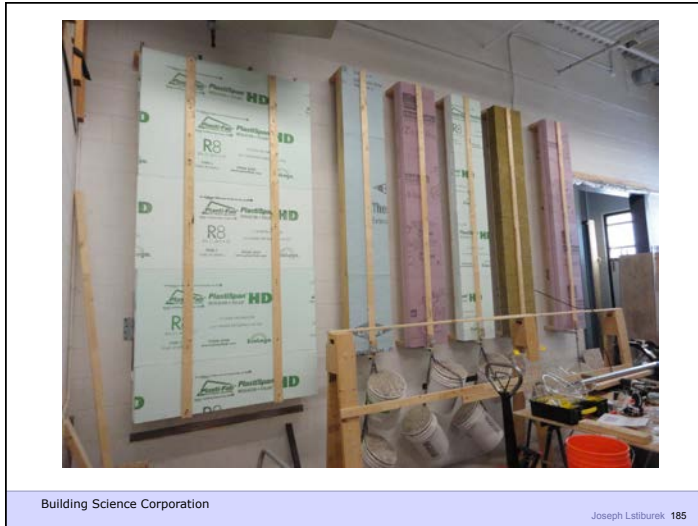

Building Science Corporation

Joseph Lstiburek 185



Building Science Corporation  
2010

Joseph Lstiburek 186

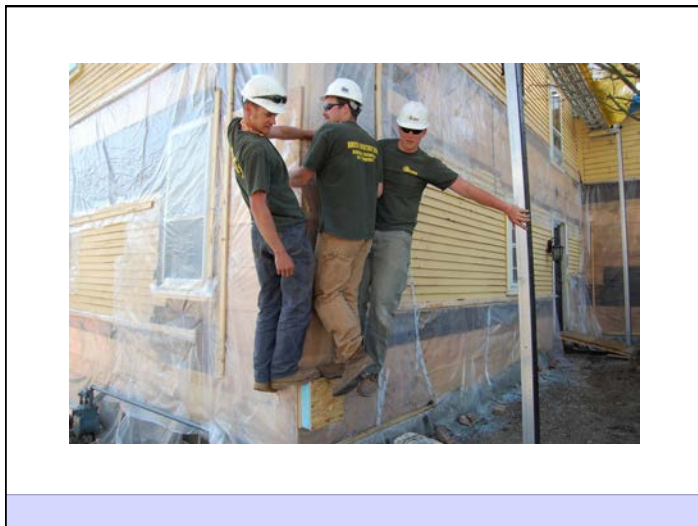

### Rockwool

1x3 furring @ 24" o.c.  
#10 screws @ 16" o.c. vertically  
Result: 20 psf cladding weight  
with < 2/100" deflection

Average Deflection of Framing (inches)	Vertical Load (psf) - Red Curve	Vertical Load (psf) - Blue Curve	Vertical Load (psf) - Green Curve
0.00	0	0	0
0.02	~1000	~500	~200
0.04	~1500	~800	~300
0.06	~1800	~1000	~350
0.08	~1900	~1100	~380
0.10	~1950	~1150	~400