

Joseph Lstiburek, Ph.D., P.Eng, ASHRAE Fellow

Building Science

Towering Inferno

www.buildingscience.com

Setting The Stage

Grenfell Tower

North Kensington, United Kingdom

June, 2017







Focus is on Cladding

Focus is on Cladding
Effective Compartmentalization
Detection and Alarm Systems
Sprinkler Systems
Egress





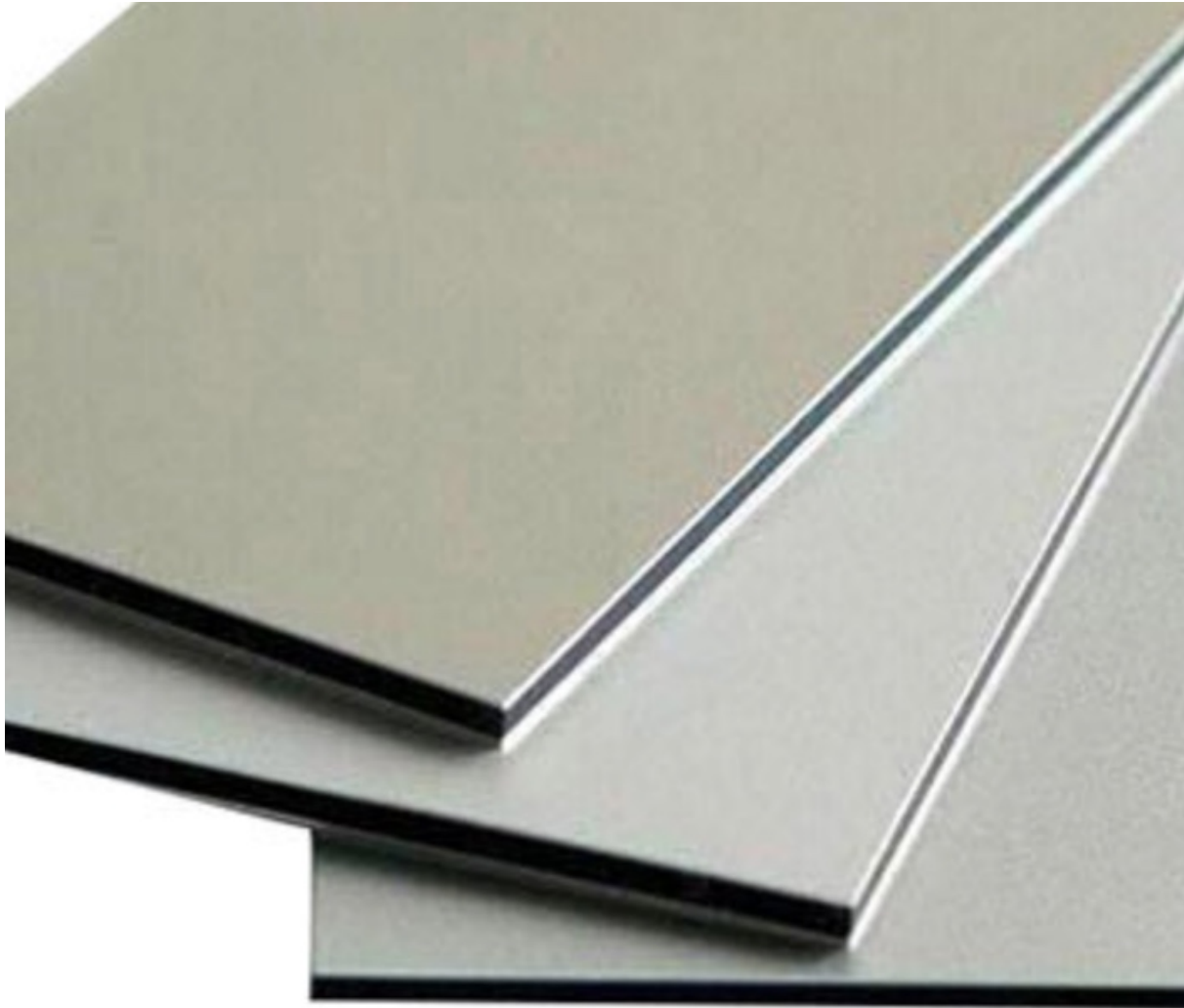

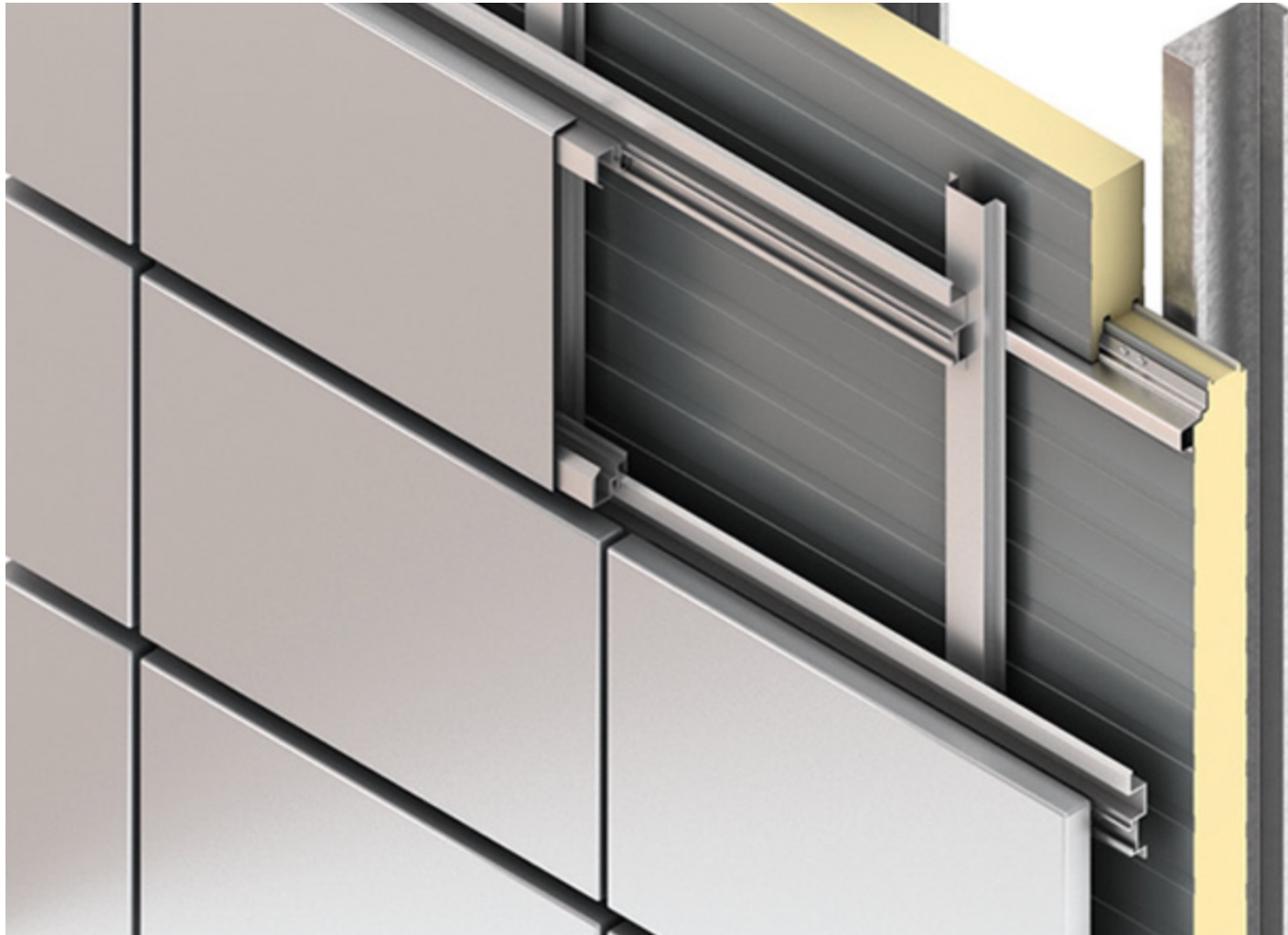

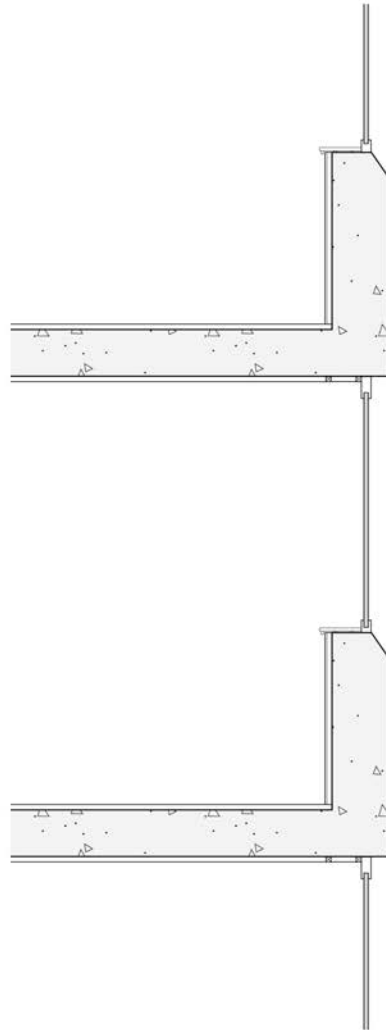

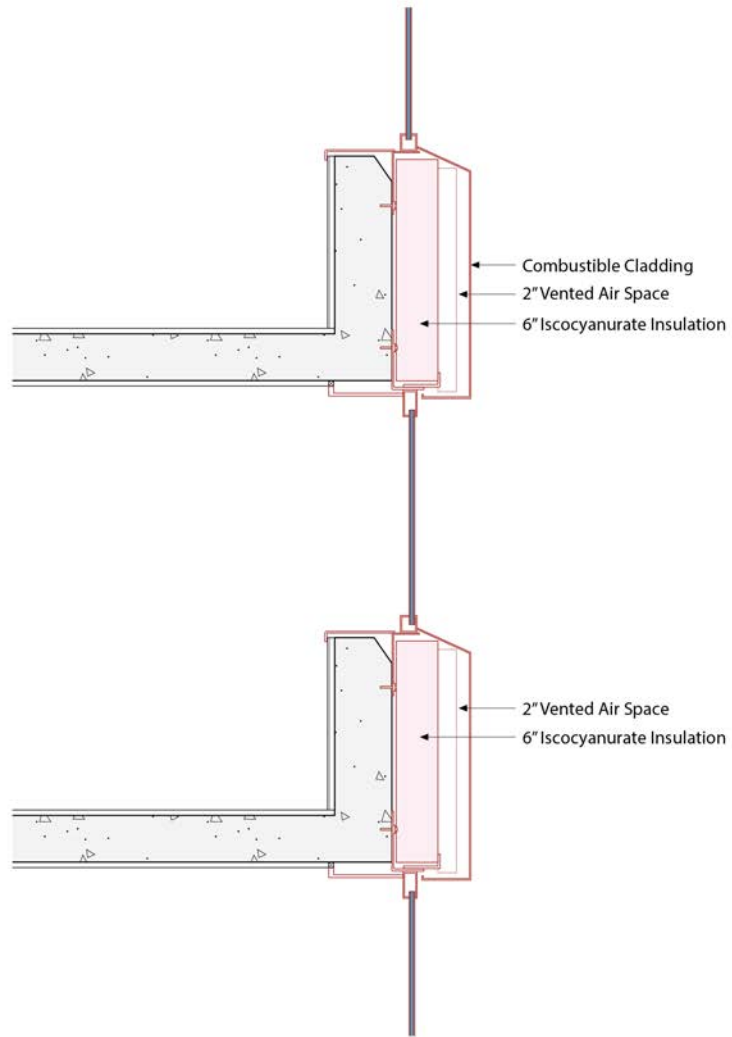

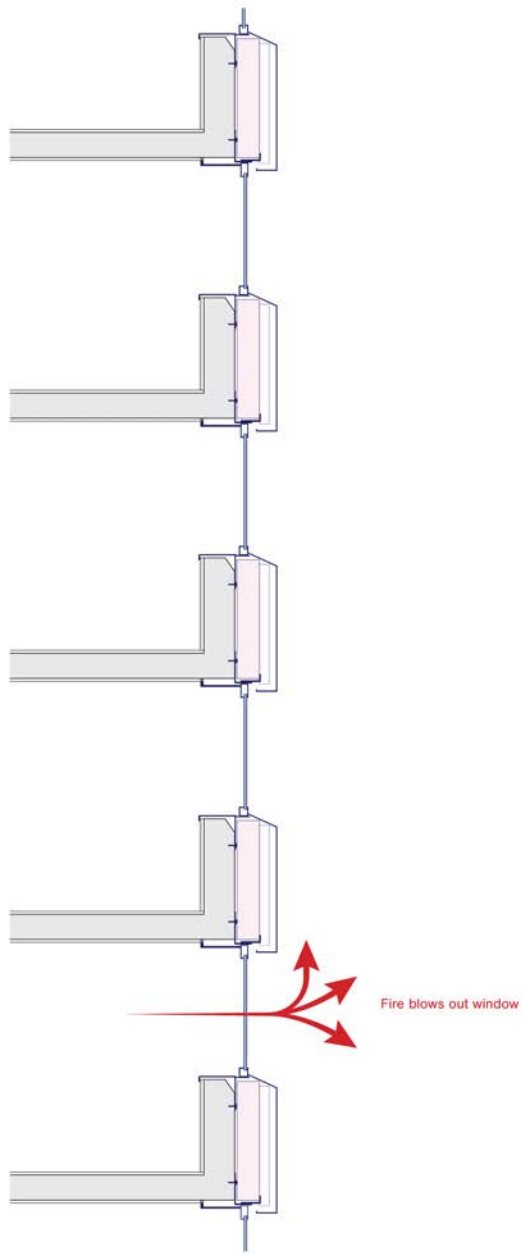

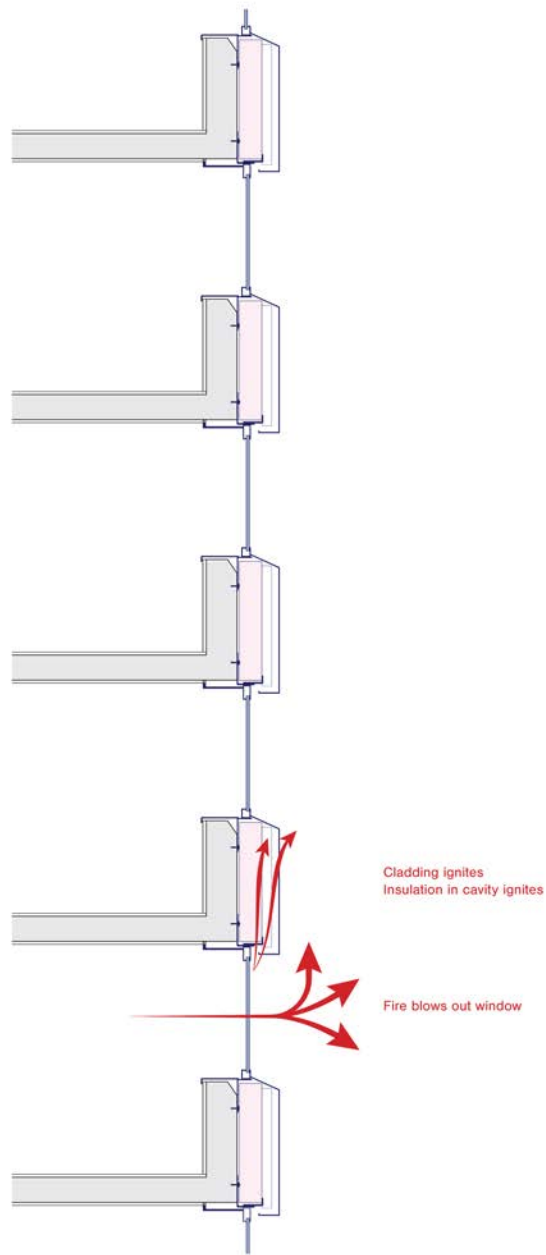

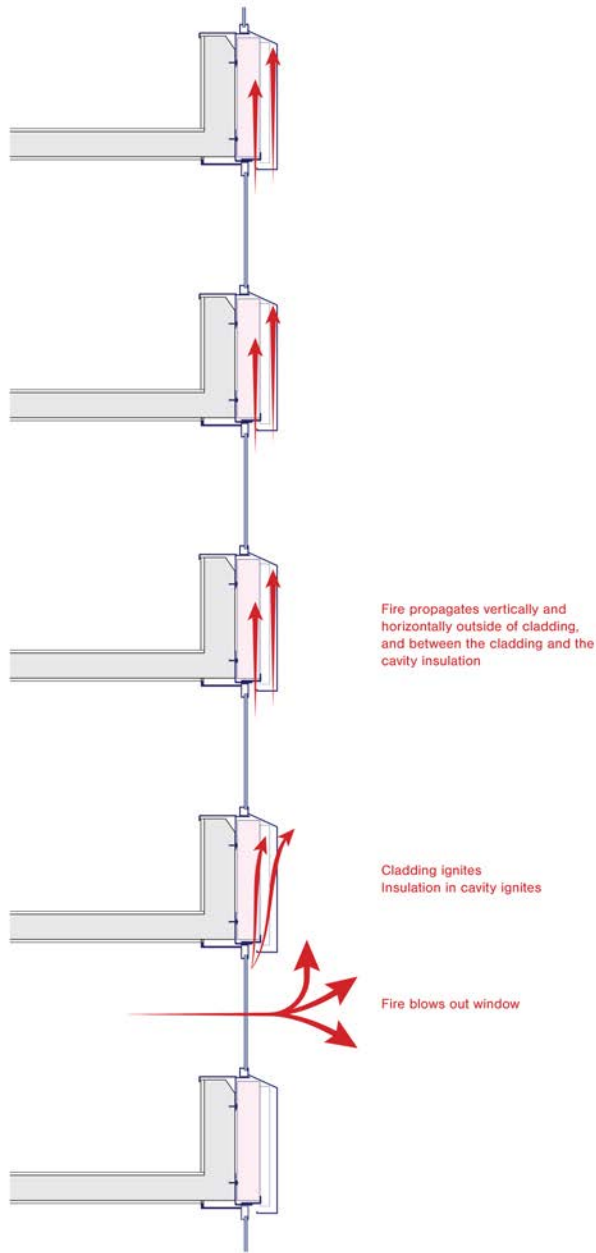

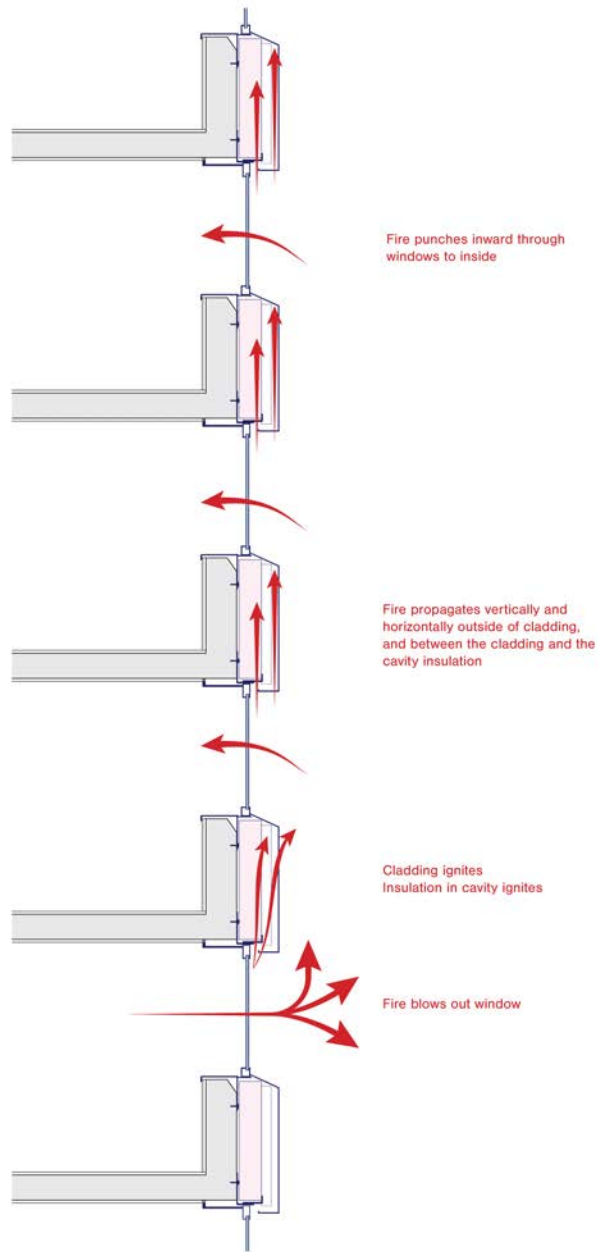

Dubai Address Hotel
Dubai, United Arab Emirates
January, 2015





Mermoz Roubaix, France

May 2012



Tamweel Tower

Dubai, United Arab Emirates

November, 2012





Al Nahda Tower
Sharjah, United Arab Emirates
April, 2012





Polat Tower
Istanbul, Turkey
July, 2012





Dubai Torch Tower
Dubai, United Arab Emirates
August, 2017





Thorn House Hotel
Rostov-on-Don, Grozny, Chechnya
September, 2017





Marco Polo Apartments
Honolulu, Hawaii
July, 2017





Trump Tower
New York, New York
April, 2018







The English Fix



Cladding Attachment



Hooker Chemical Building Niagara Falls, New York





John E. Jaqua Academic Center
University of Oregon,
Eugene, Oregon





Stattdor Building Dusseldorf, Germany





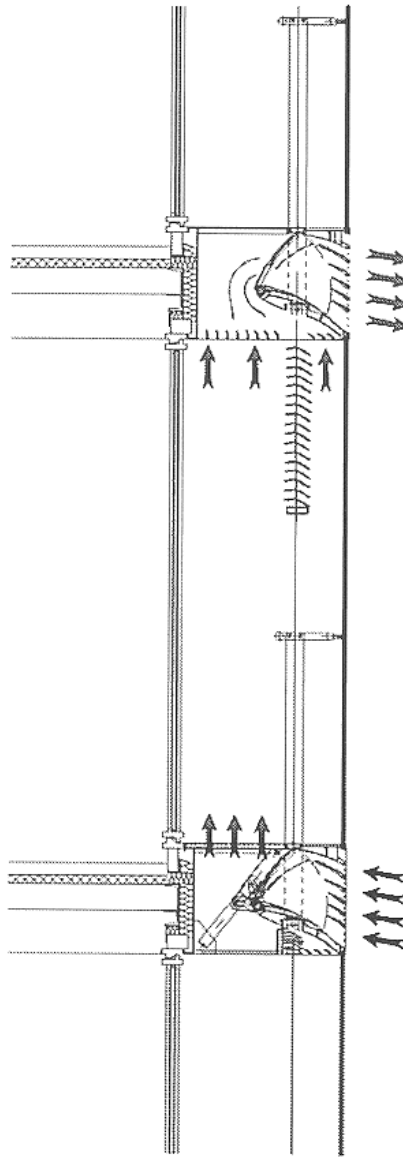

Where I Grew Up













Rain



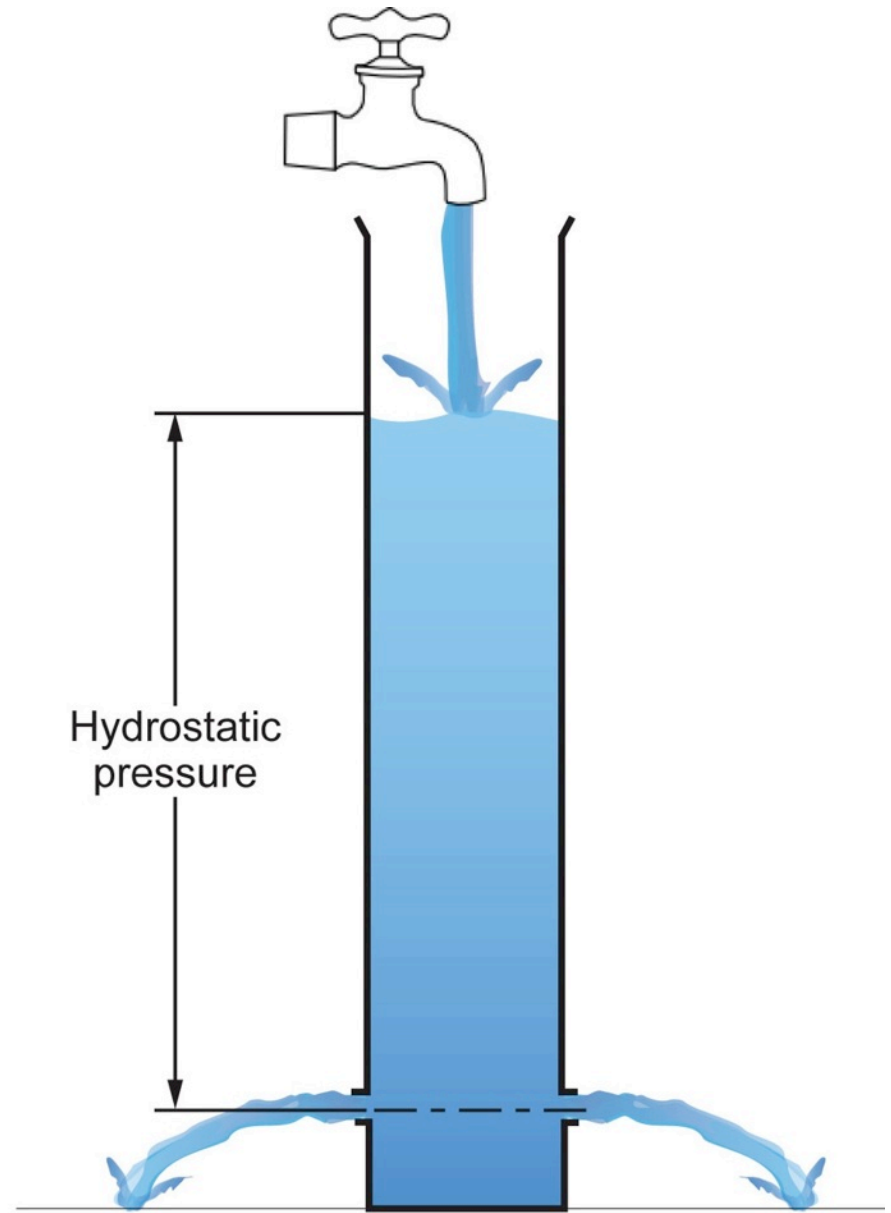
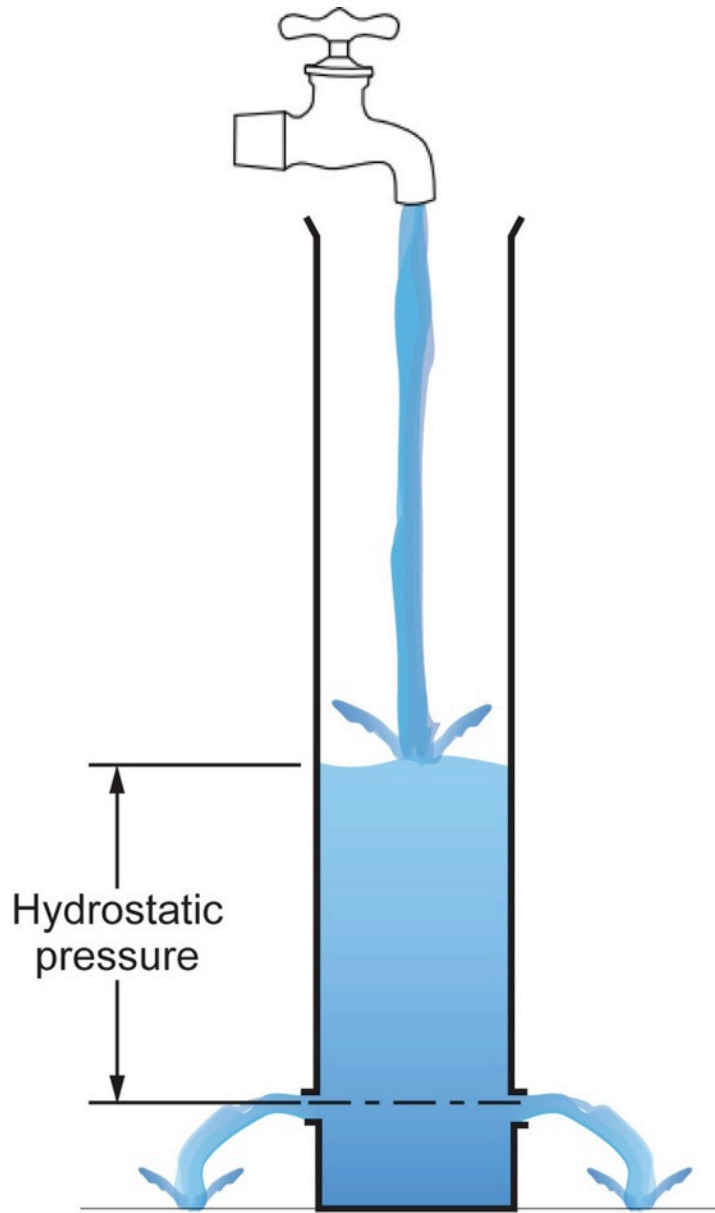



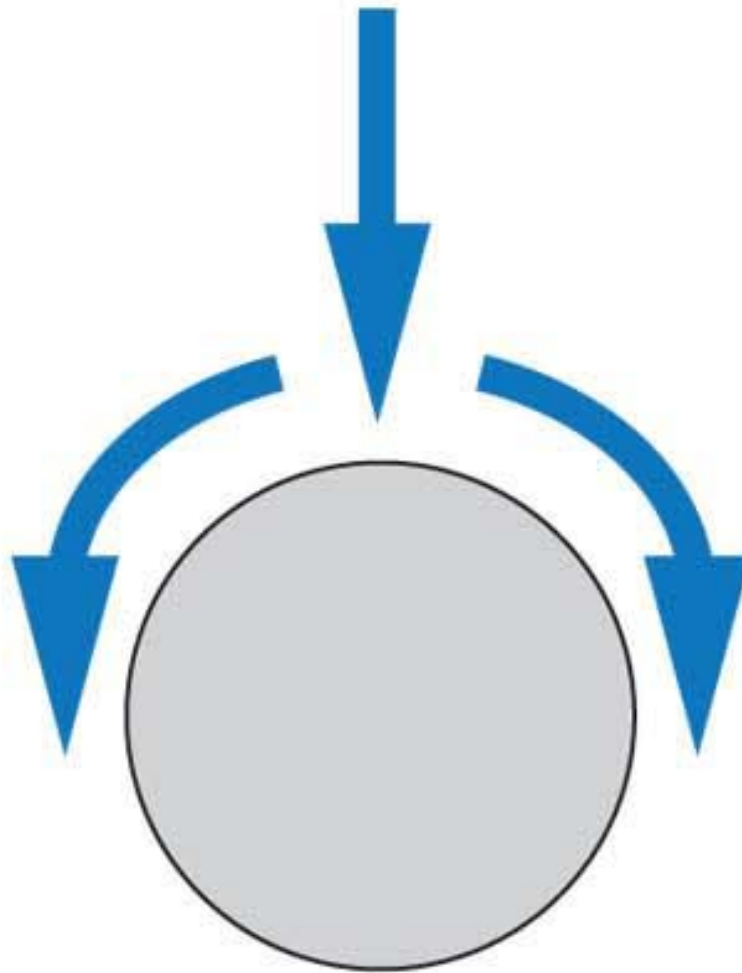

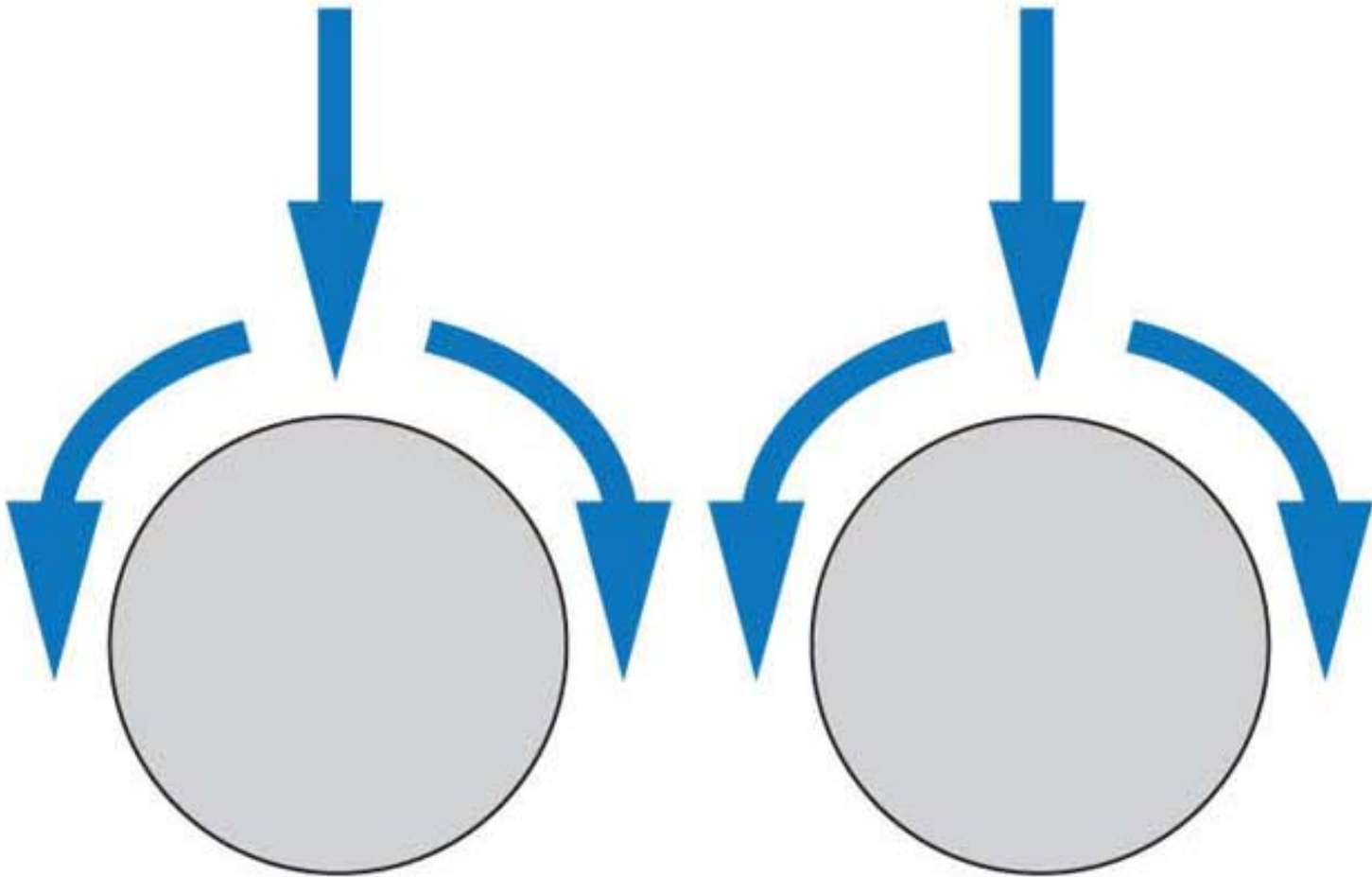

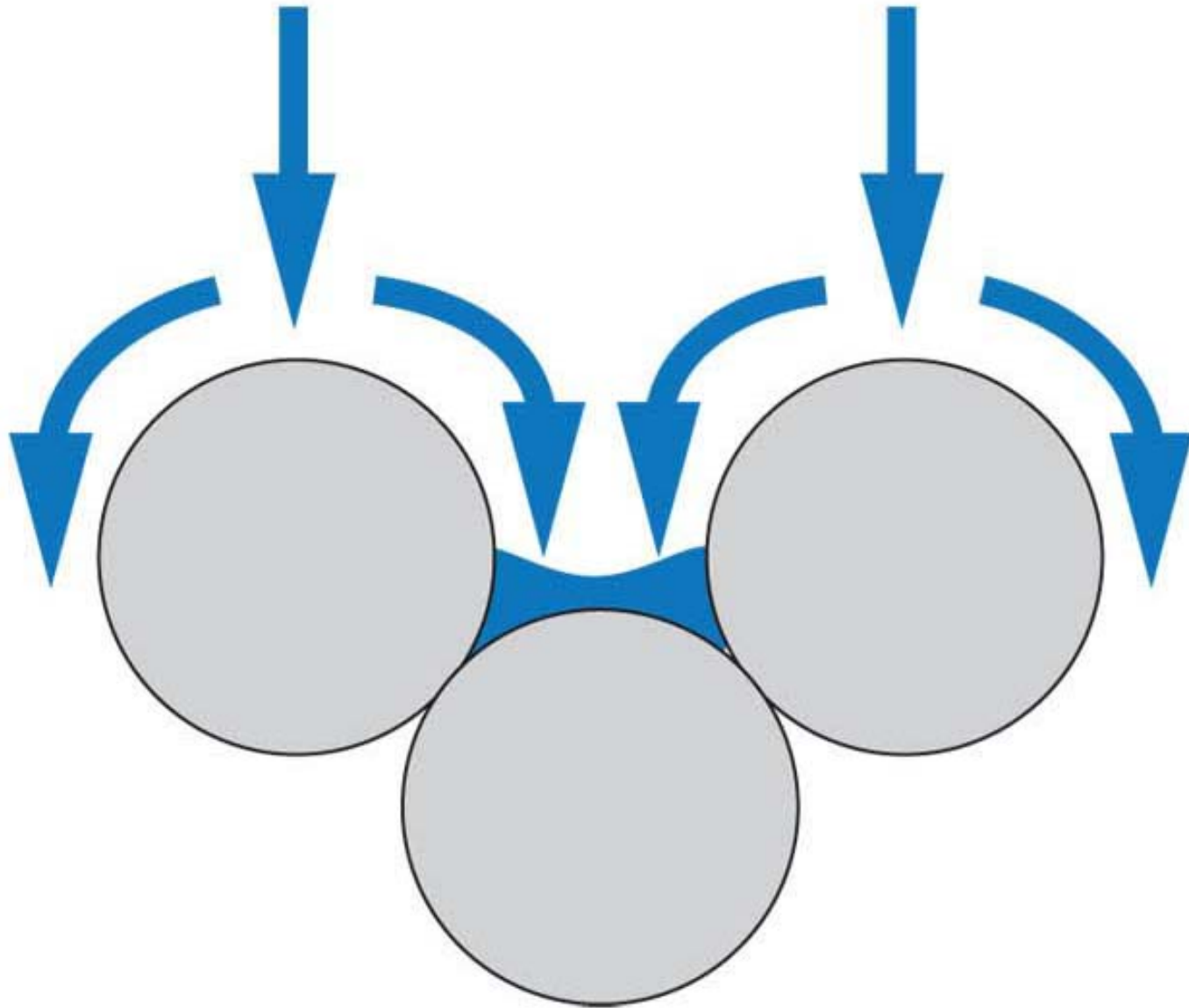

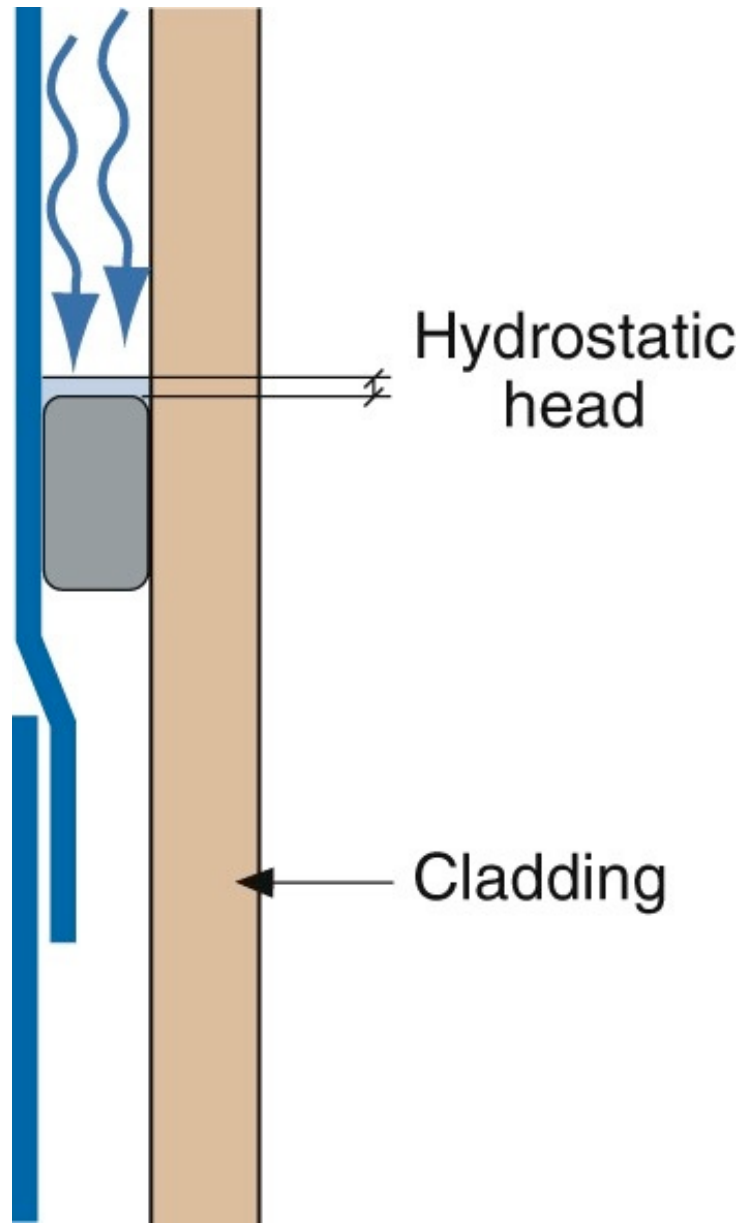

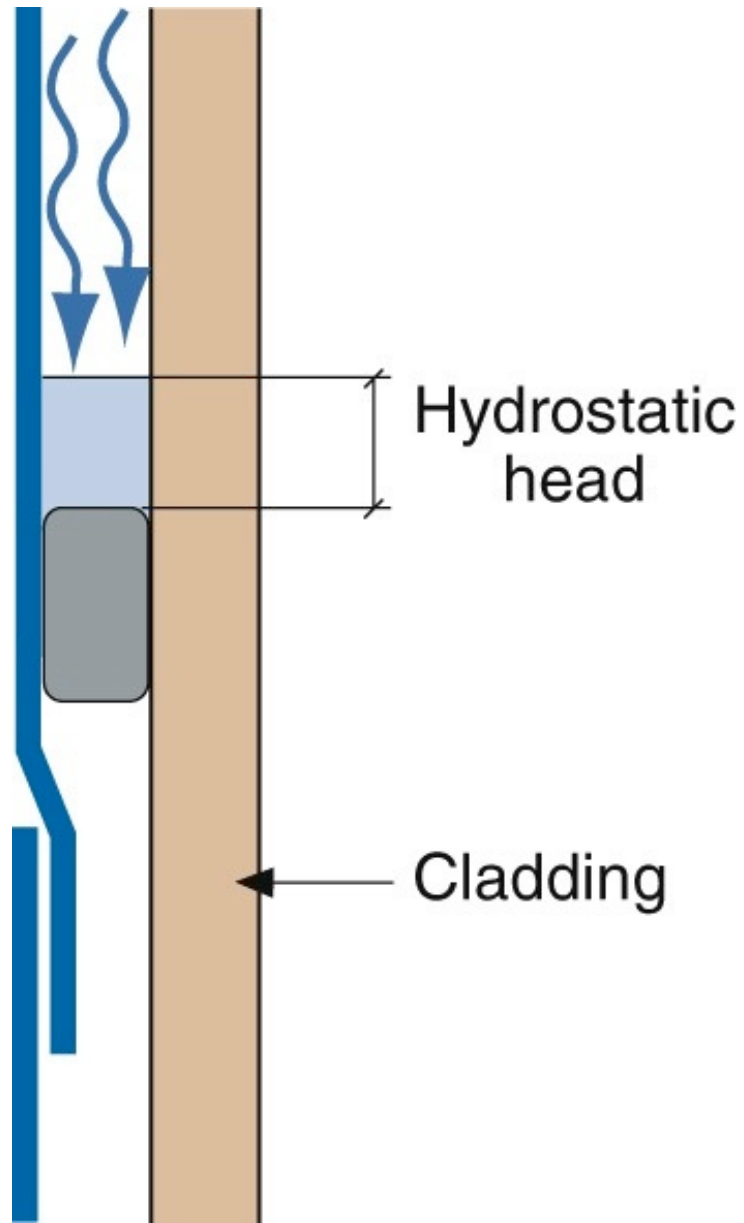

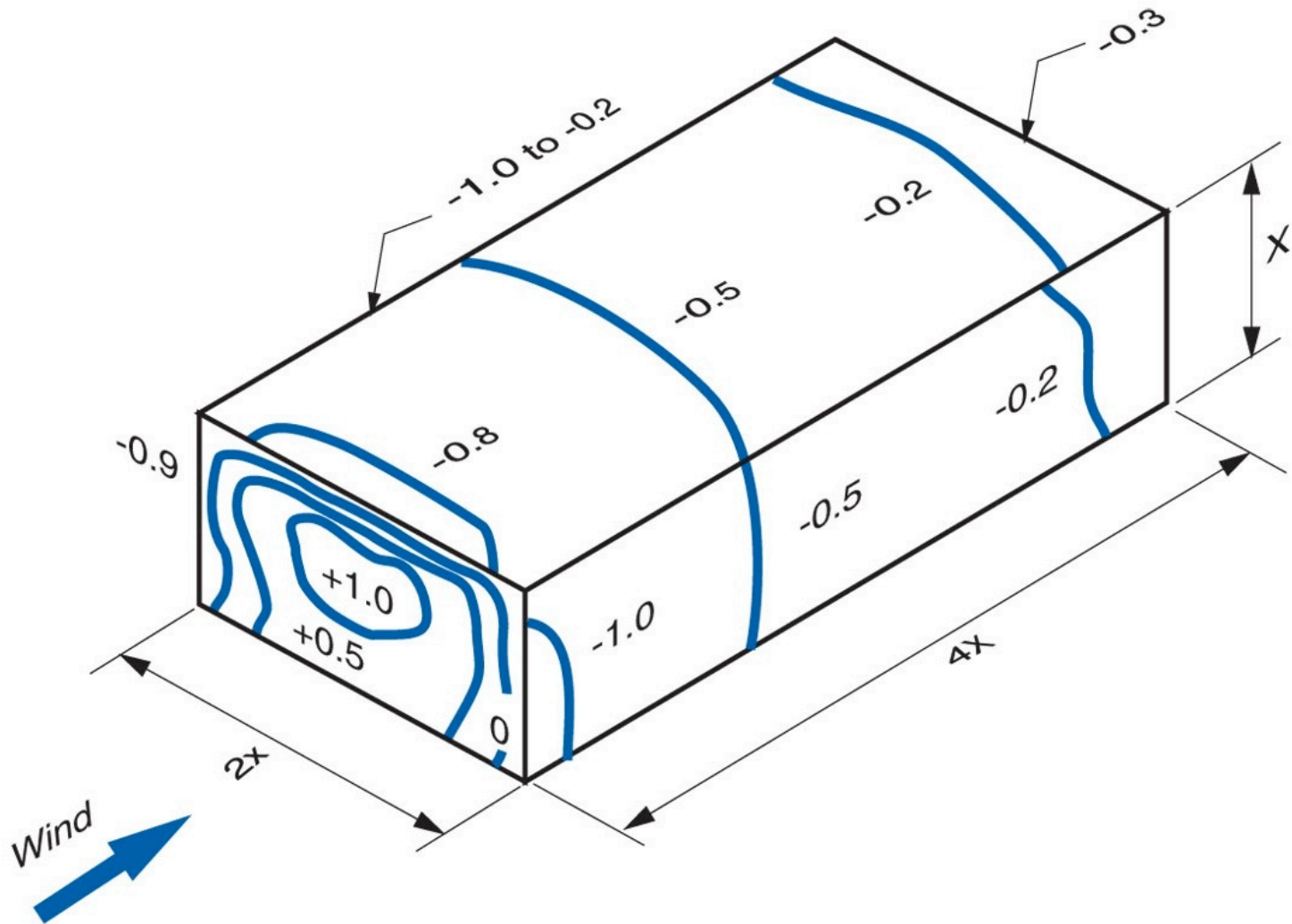

Pascals	mph
50	Pa = 20 mph
100	Pa = 30 mph
150	Pa = 35 mph
250	Pa = 45 mph
500	Pa = 65 mph
1,000	Pa = 90 mph

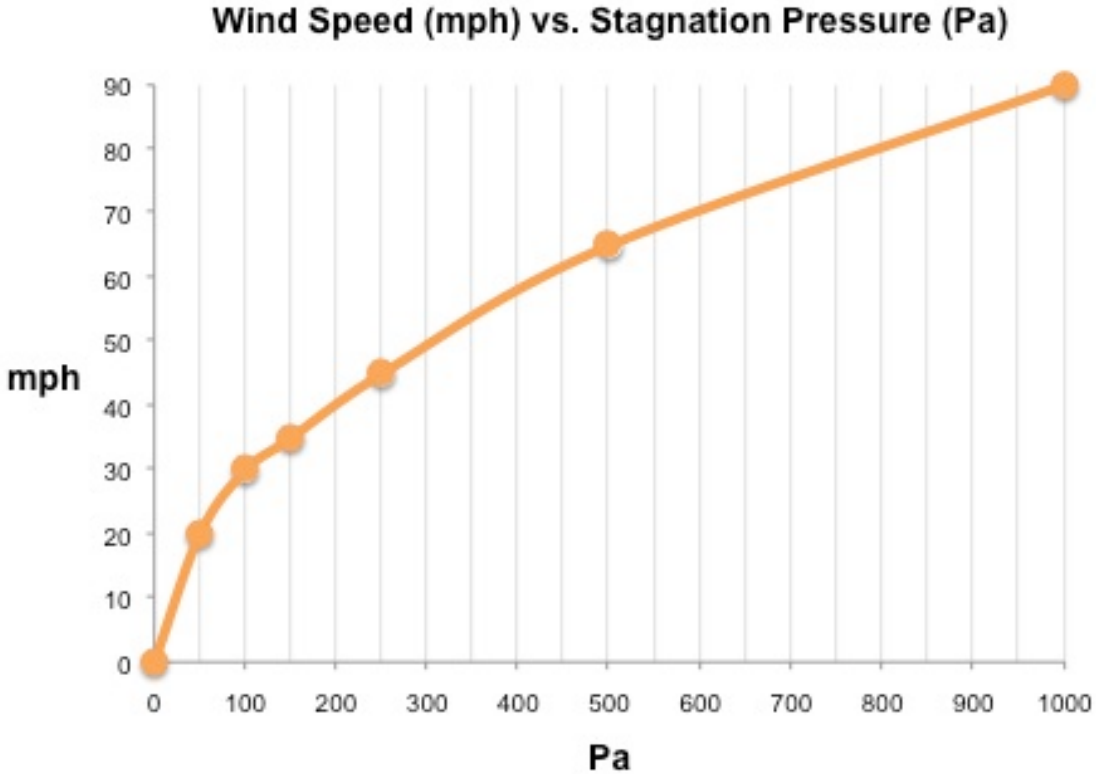

Rain Screen

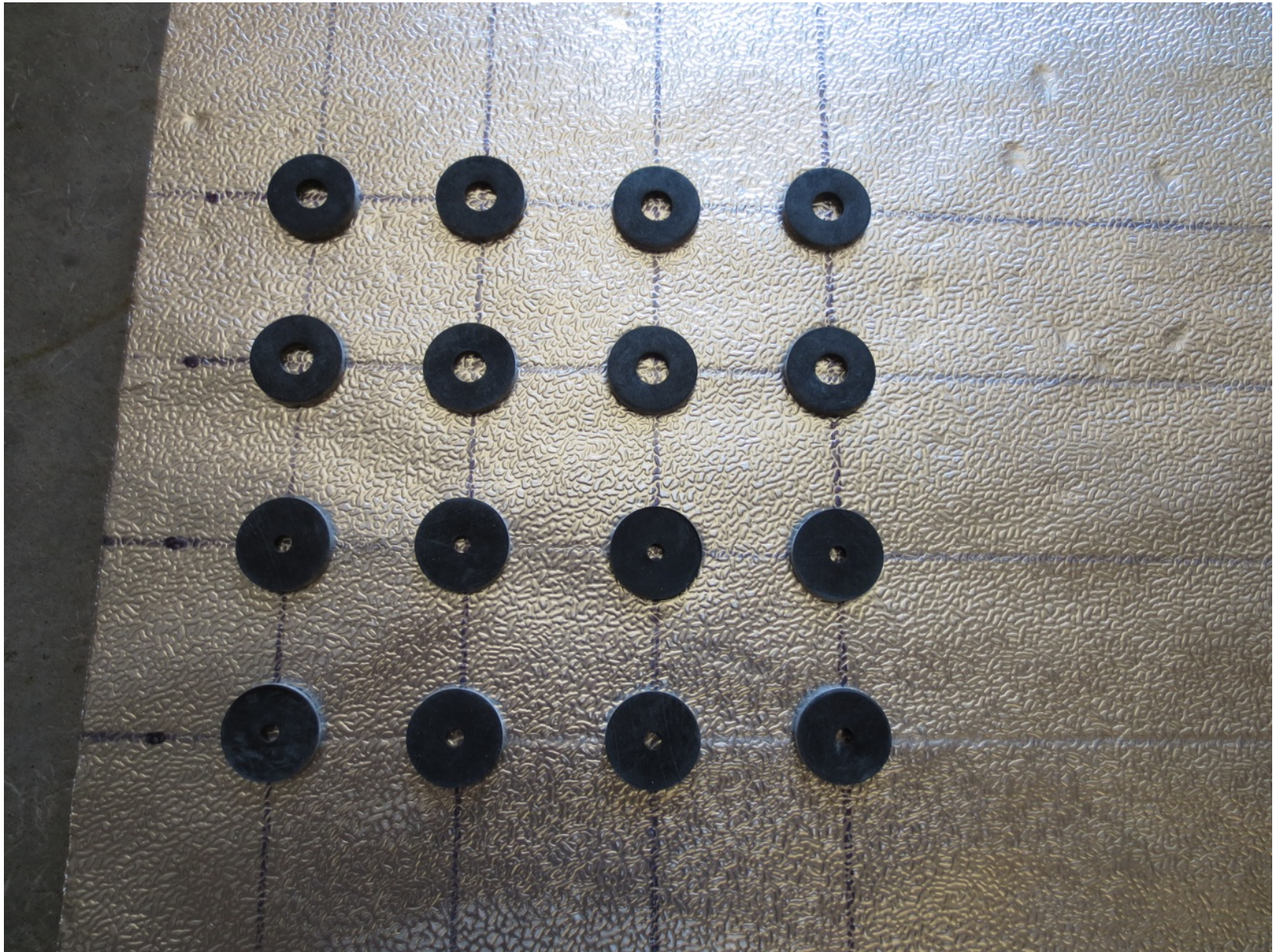





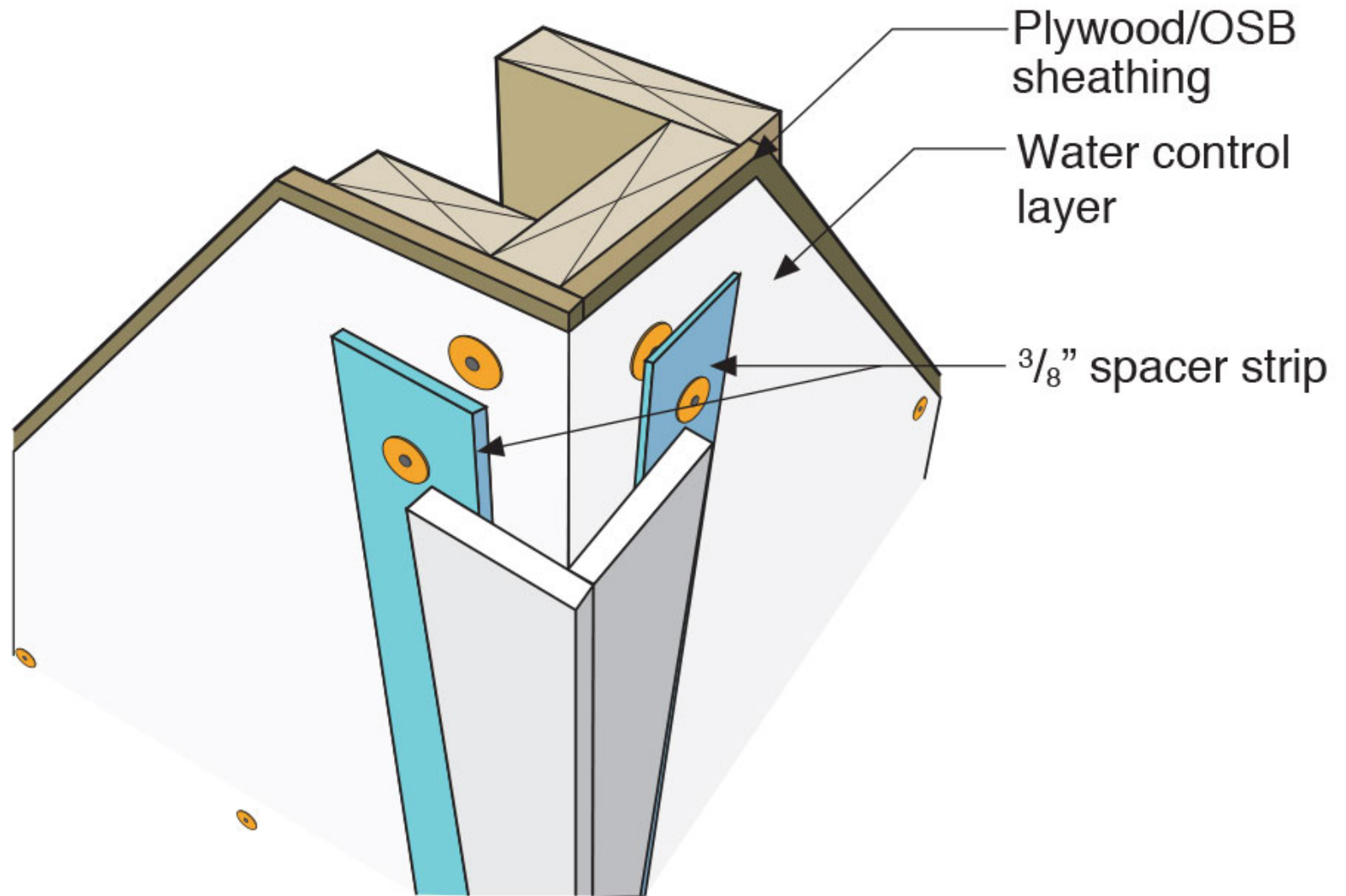





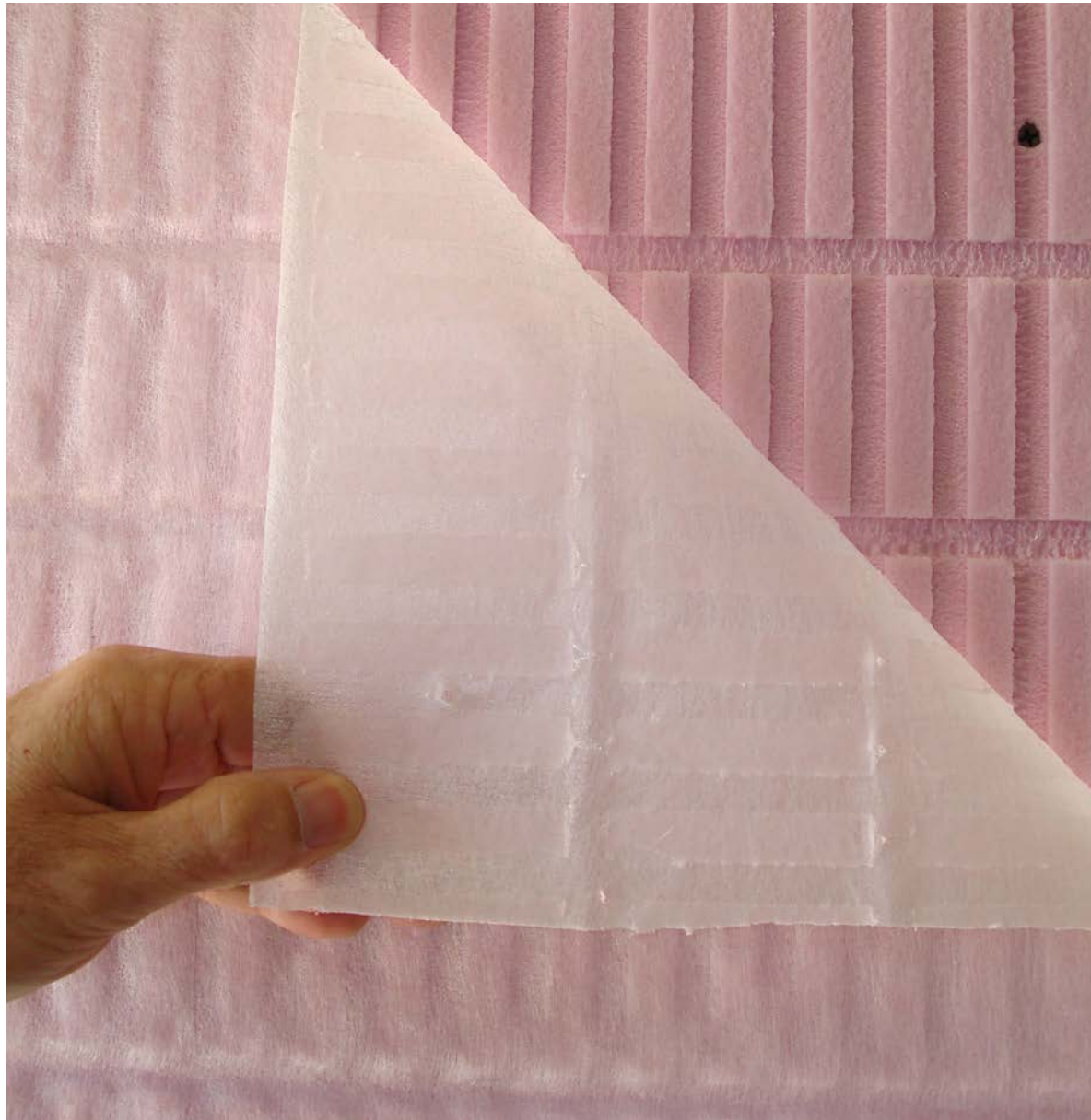

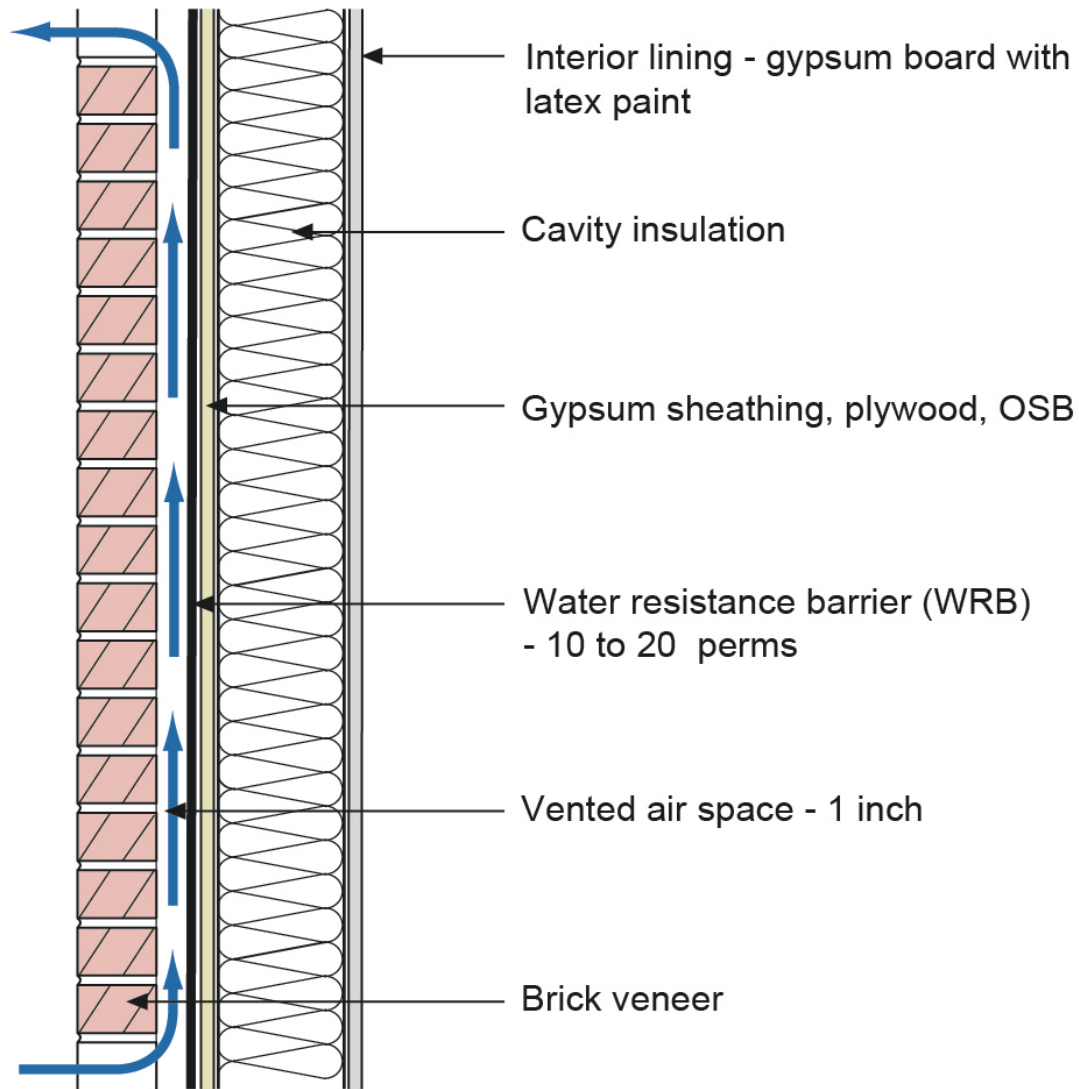

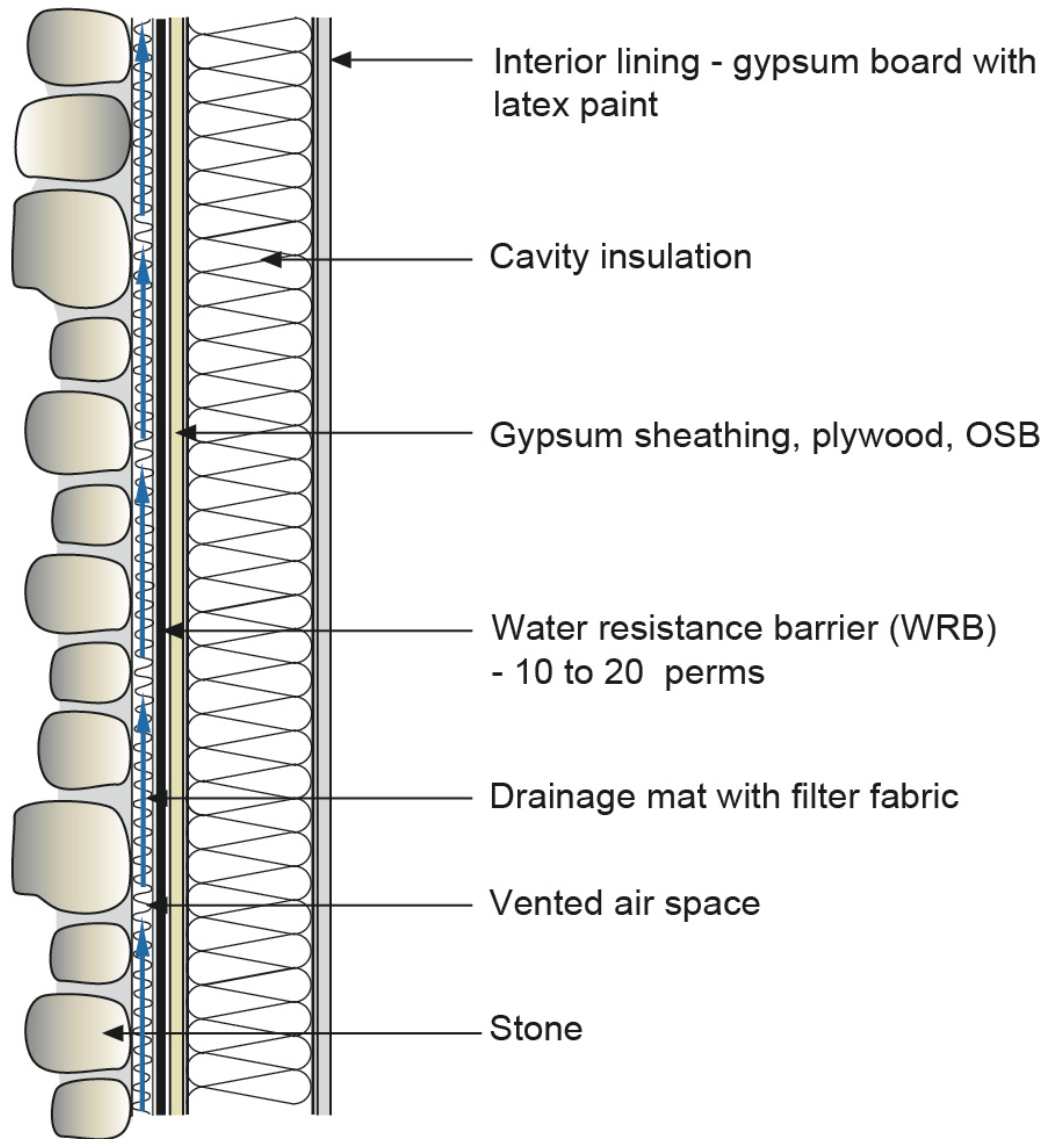

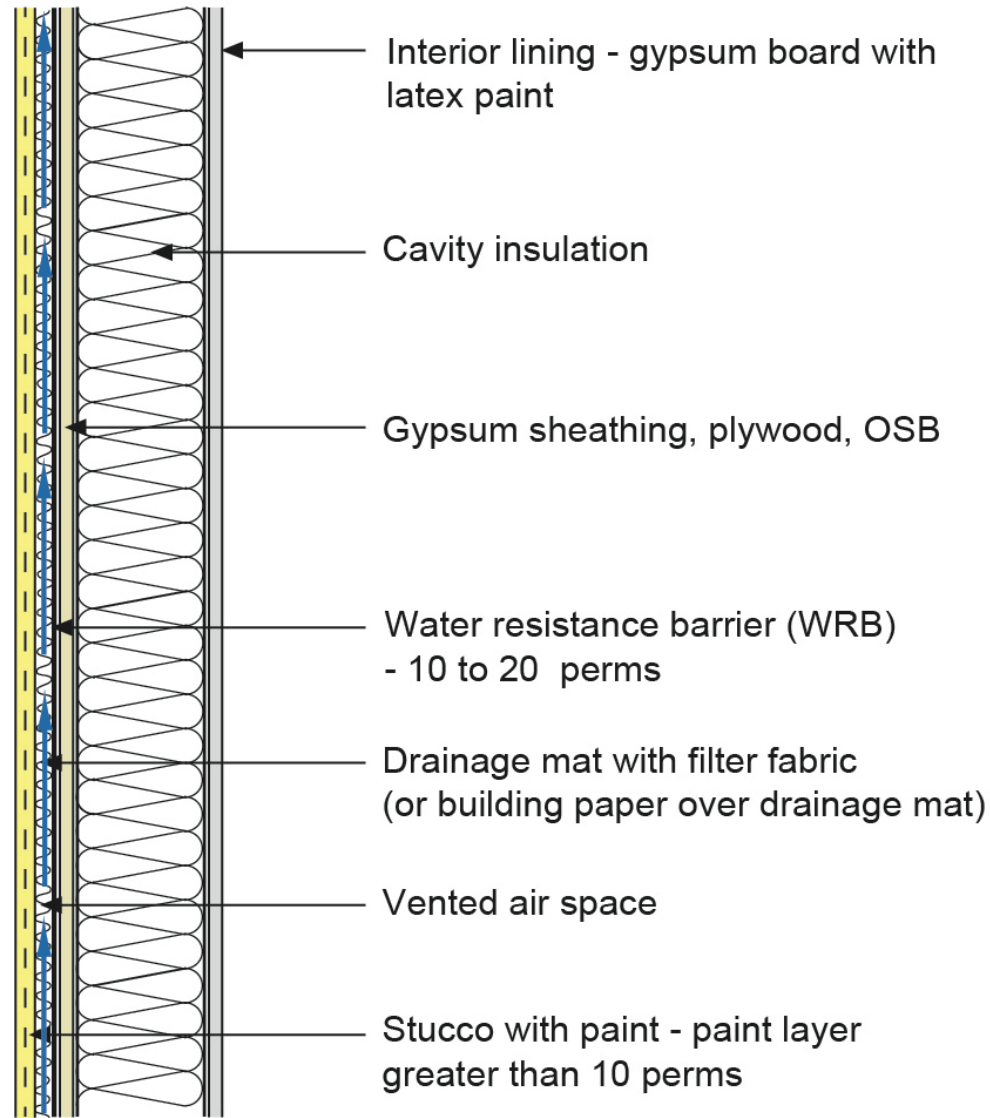

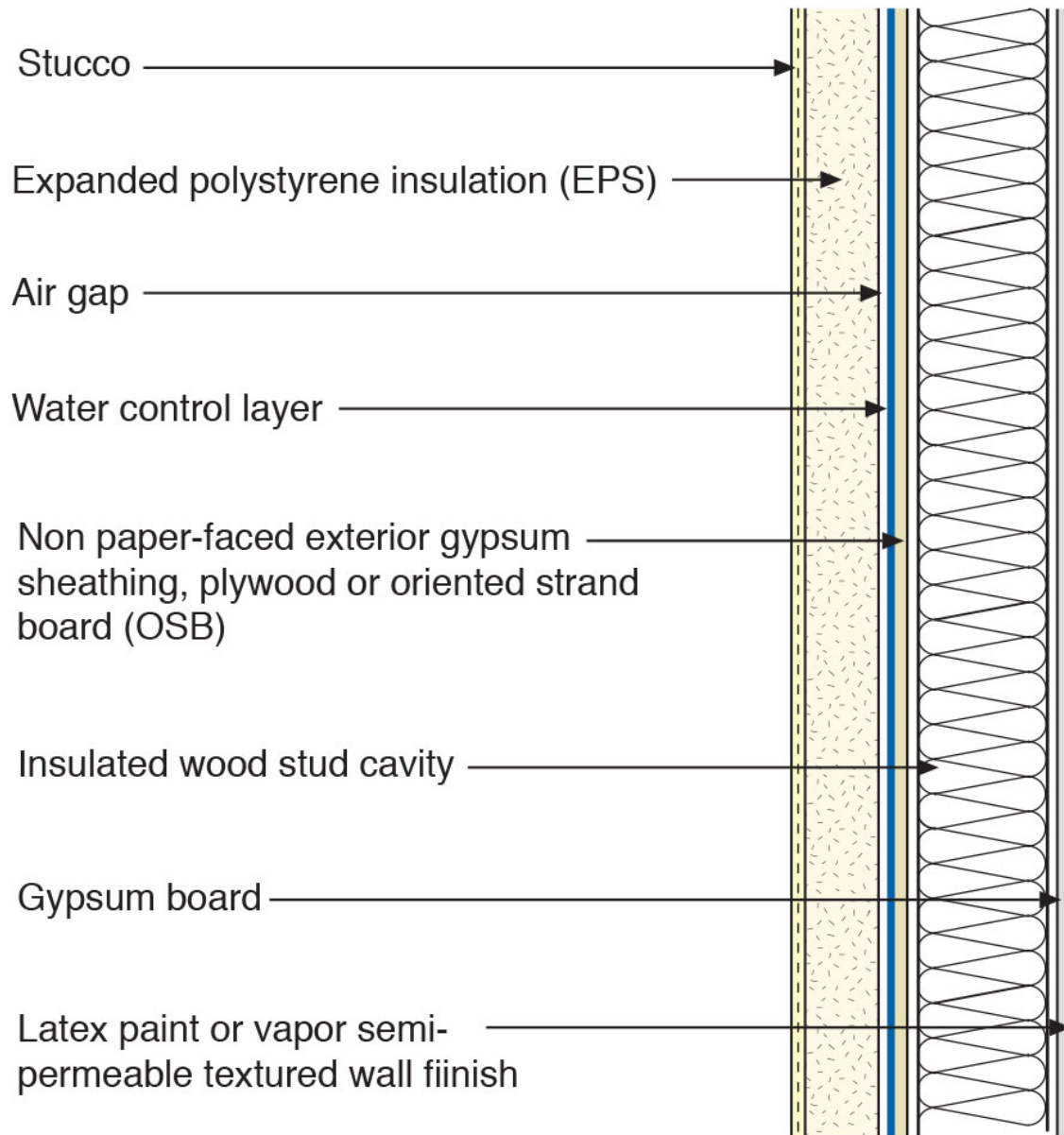

Cladding Attachment

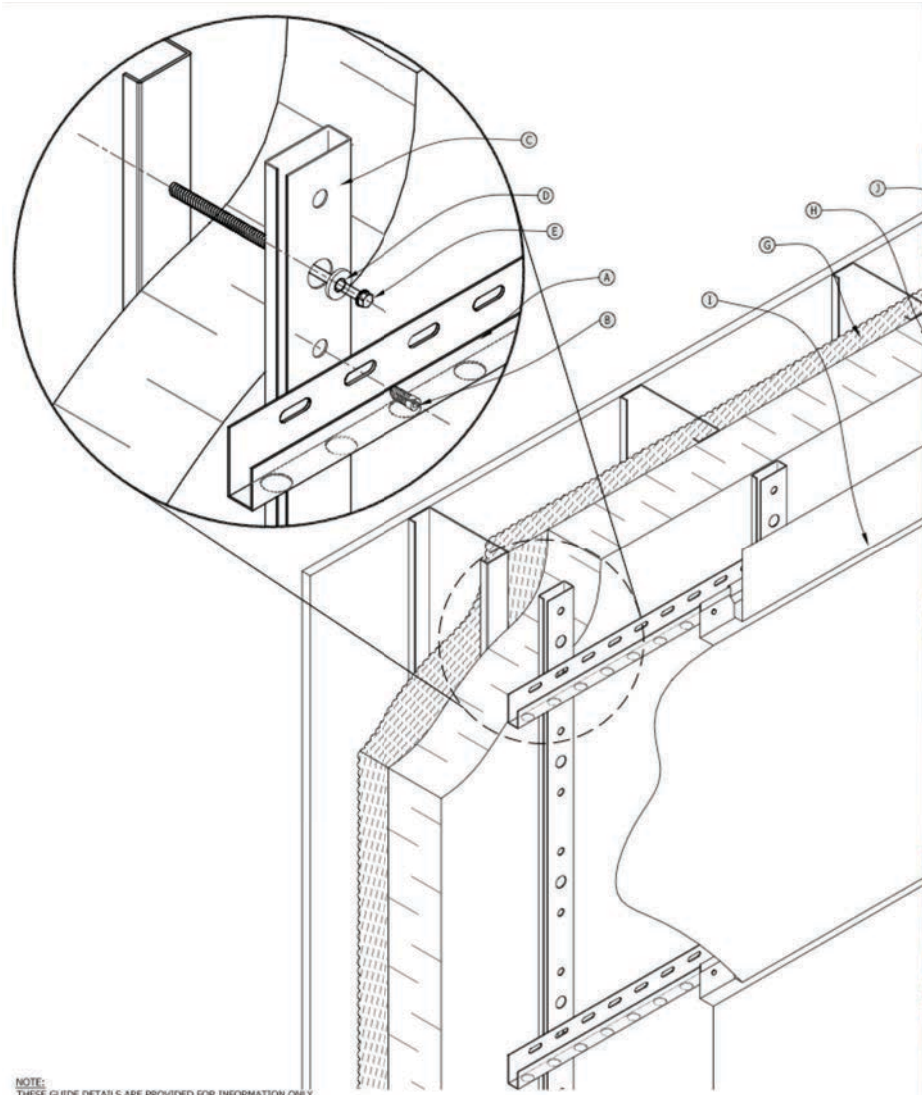

NOTE: THIS IS NOT A FINAL PRODUCT AND IS PROVIDED FOR INFORMATION ONLY

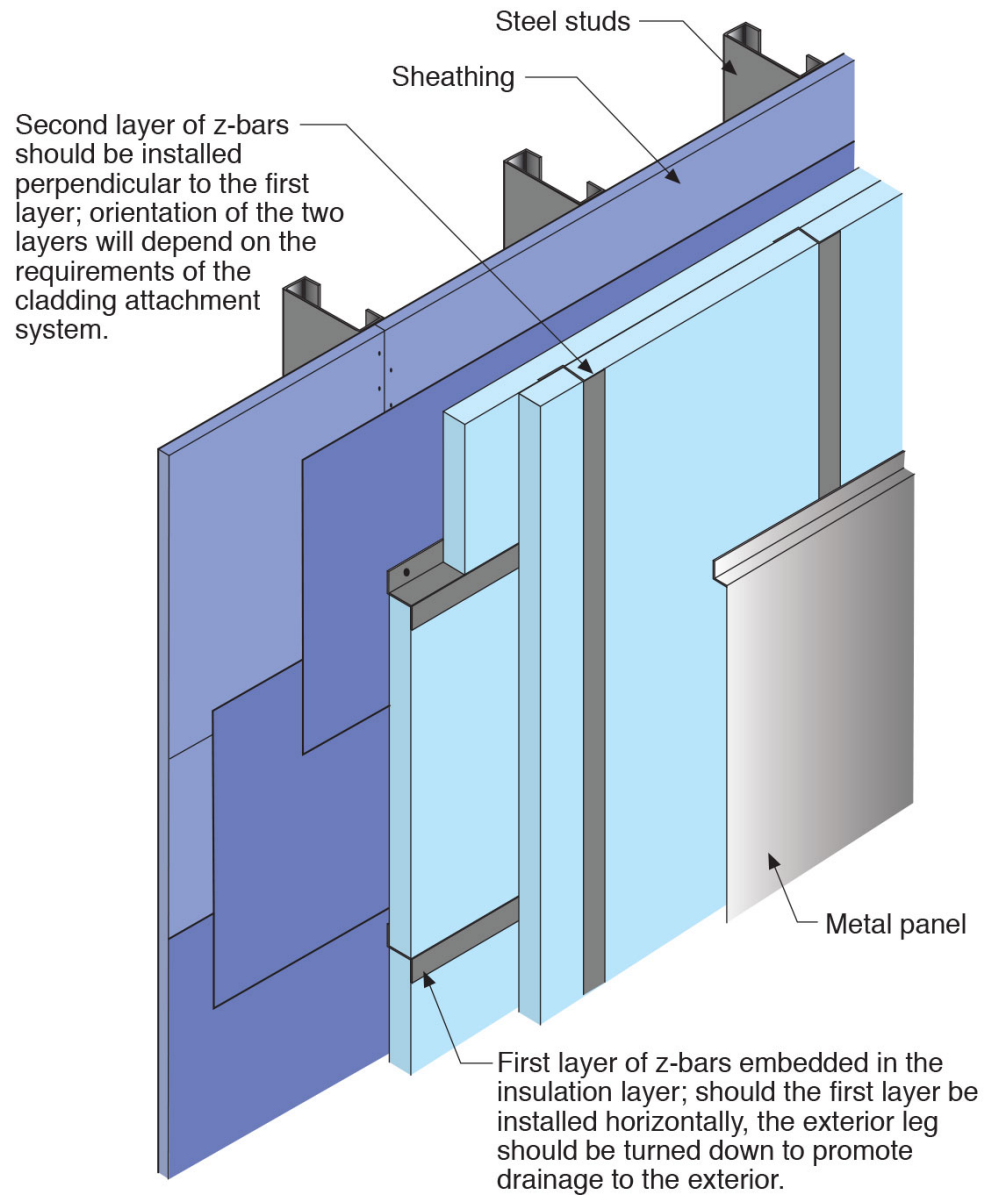

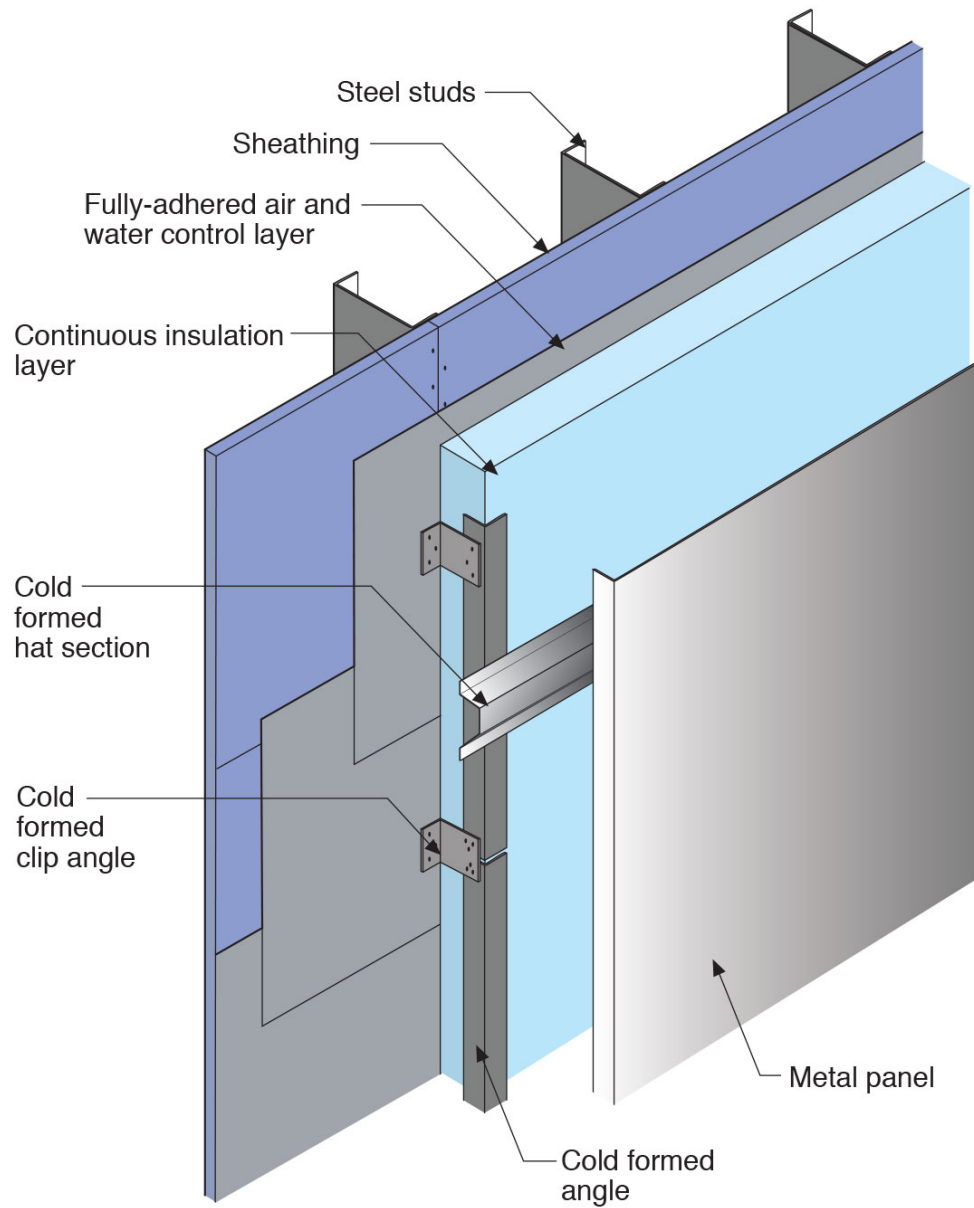



Open Rain Screen

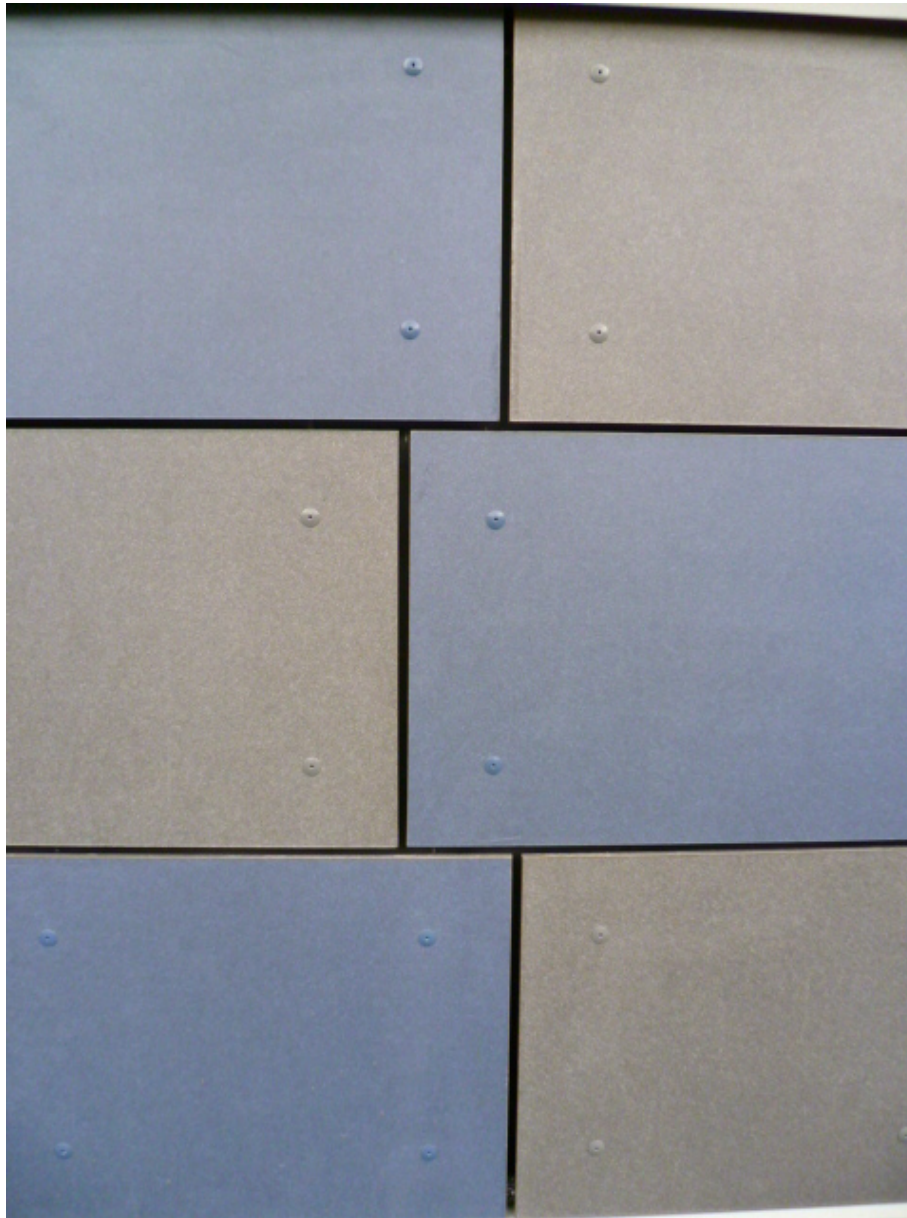







EIFS....”Drain Screen”

Beer Screen?

TYPICAL EIFS CONFIGURATION

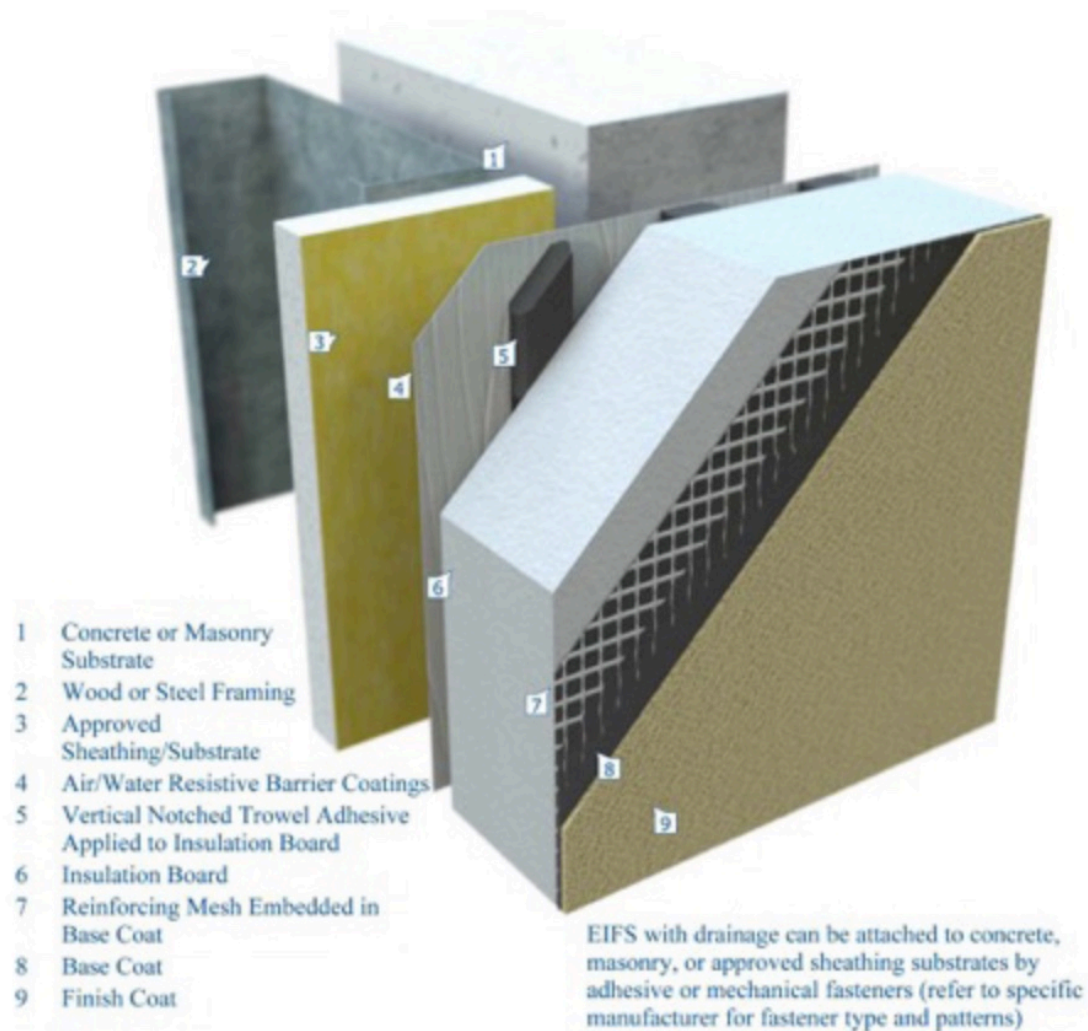

Beer Screen?

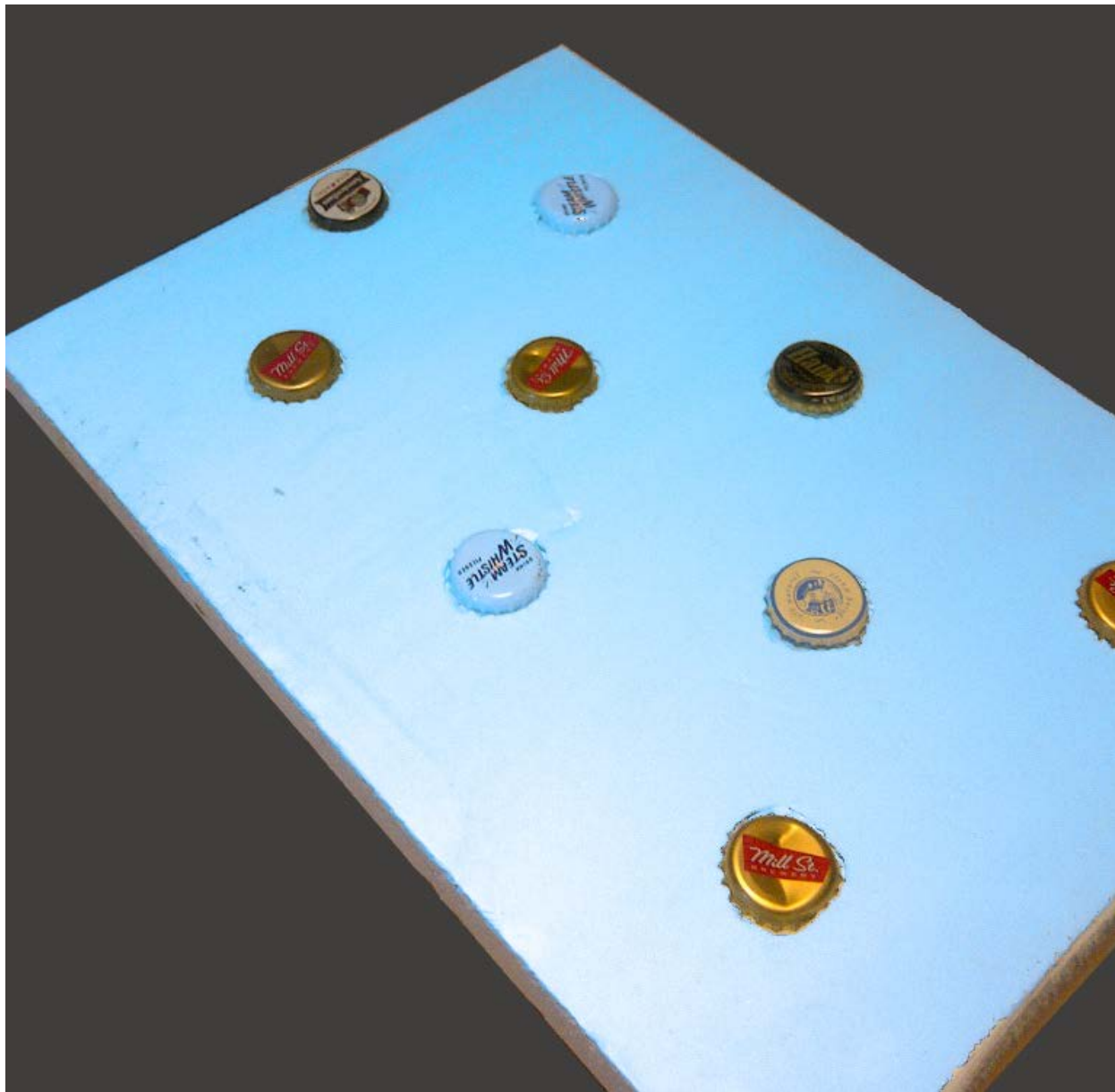

NFPA 285



Image Courtesy Payette



Image Courtesy Payette

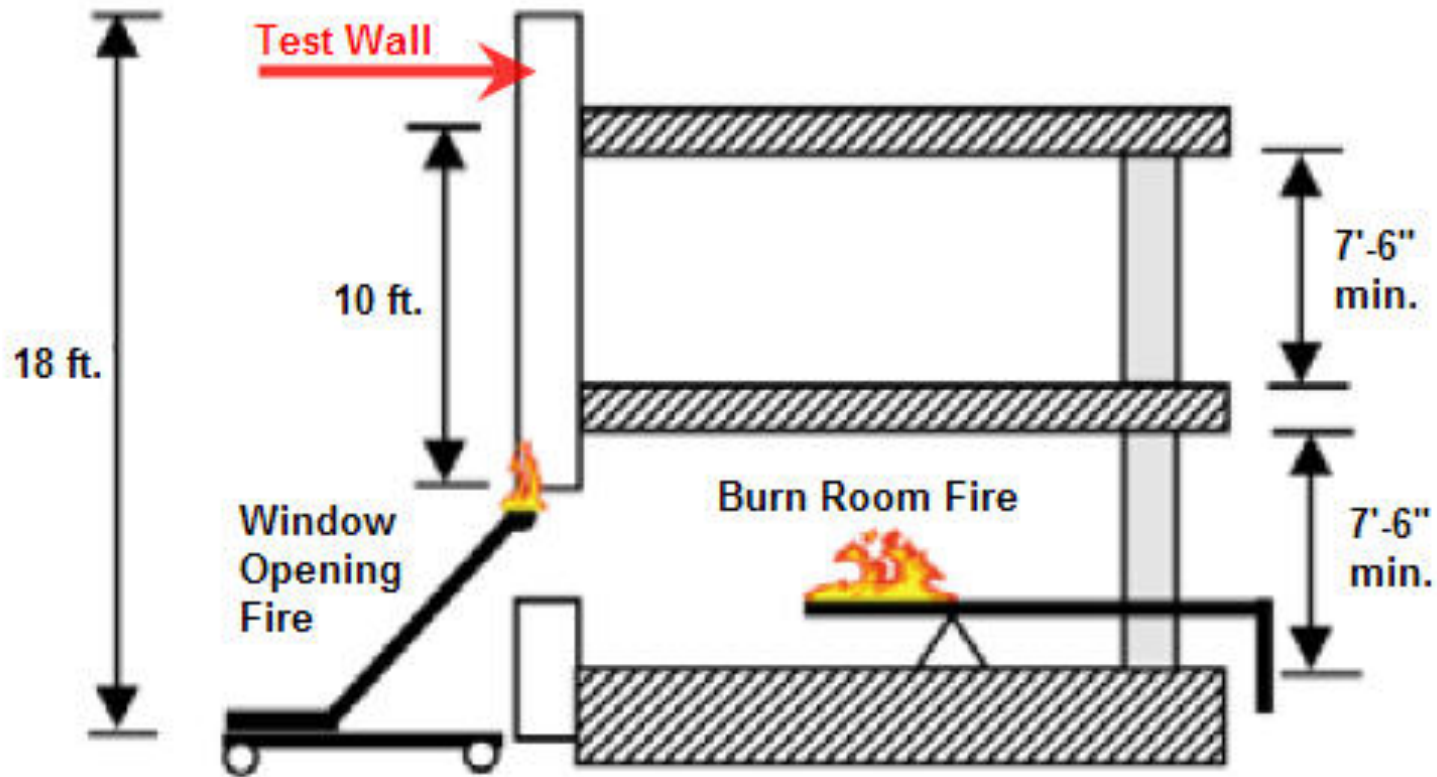

Image Courtesy Carlisle

Thank Jesse Beitel....