

Joseph Lstiburek, Ph.D., P.Eng, ASHRAE Fellow

Building Science

Adventures In Building Science

www.buildingscience.com

Life Is Tough Enough As It Is...

Life Is Tough Enough As It Is...
It's Harder When You Are Stupid...

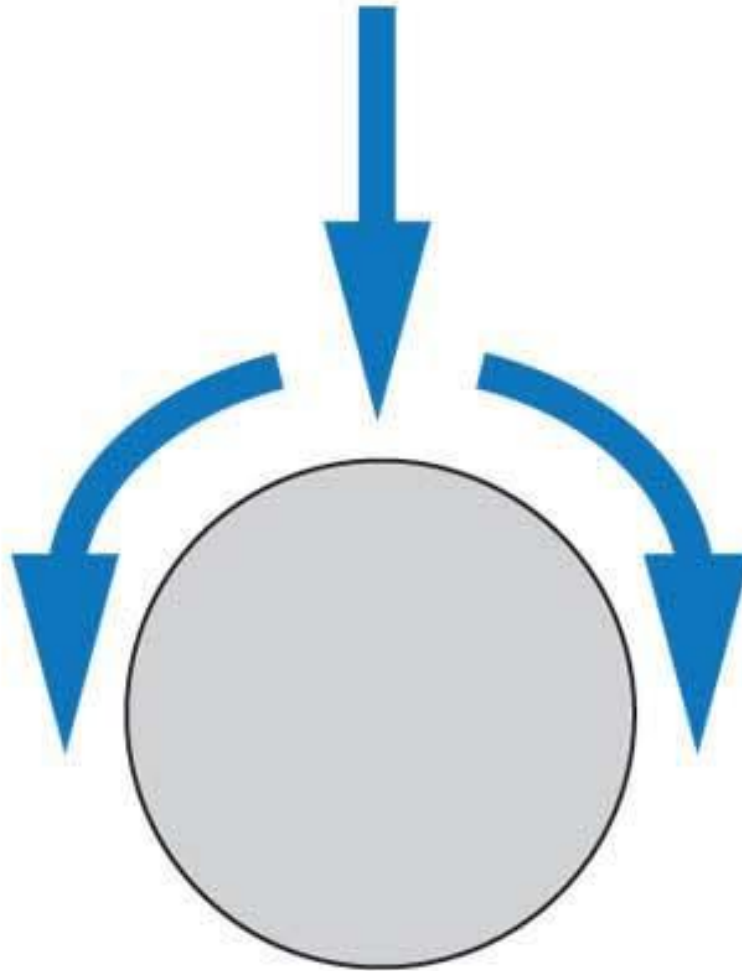
Life Is Tough Enough As It Is...
It's Harder When You Are Stupid...
Don't Do Stupid Things...

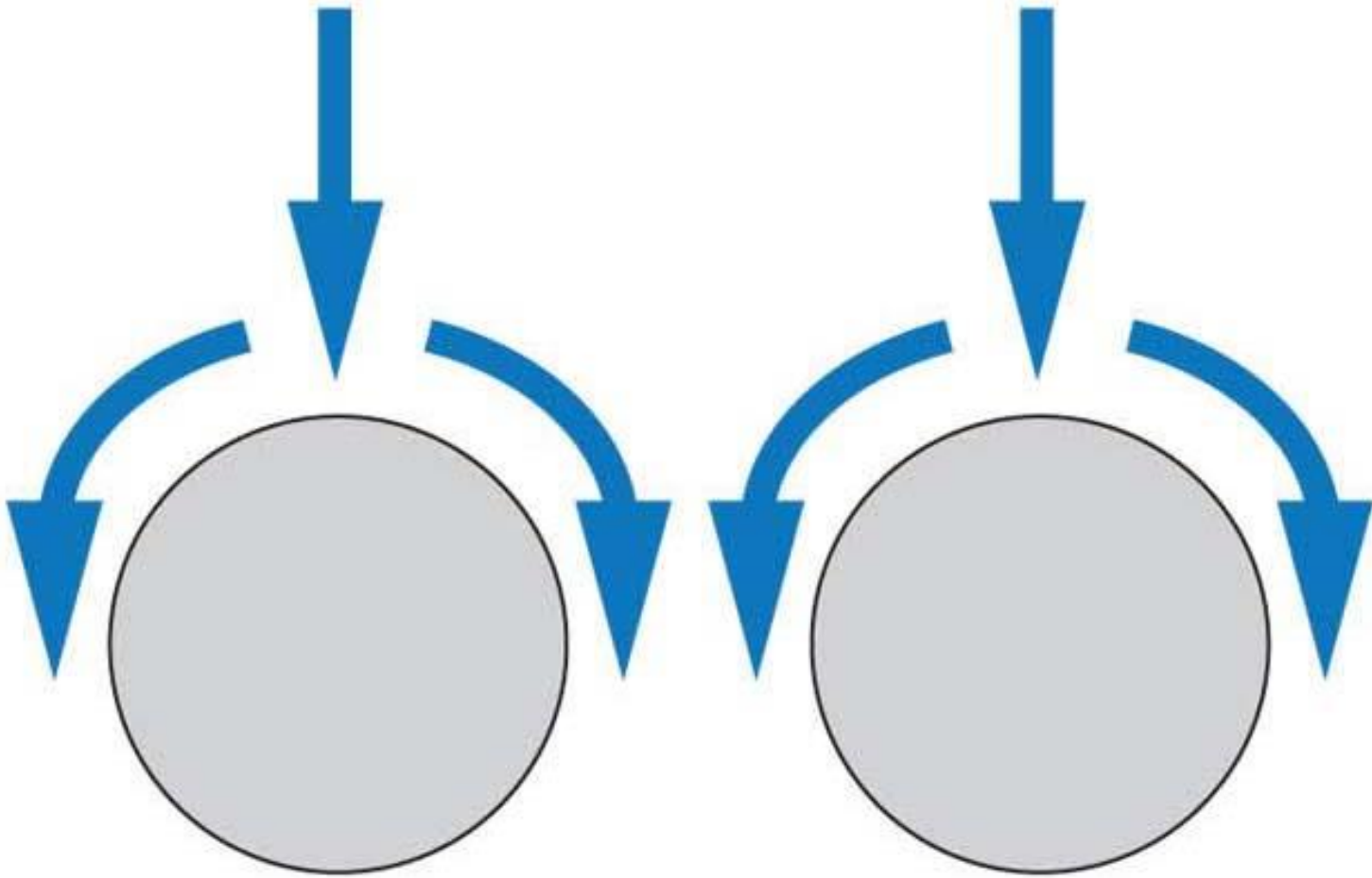


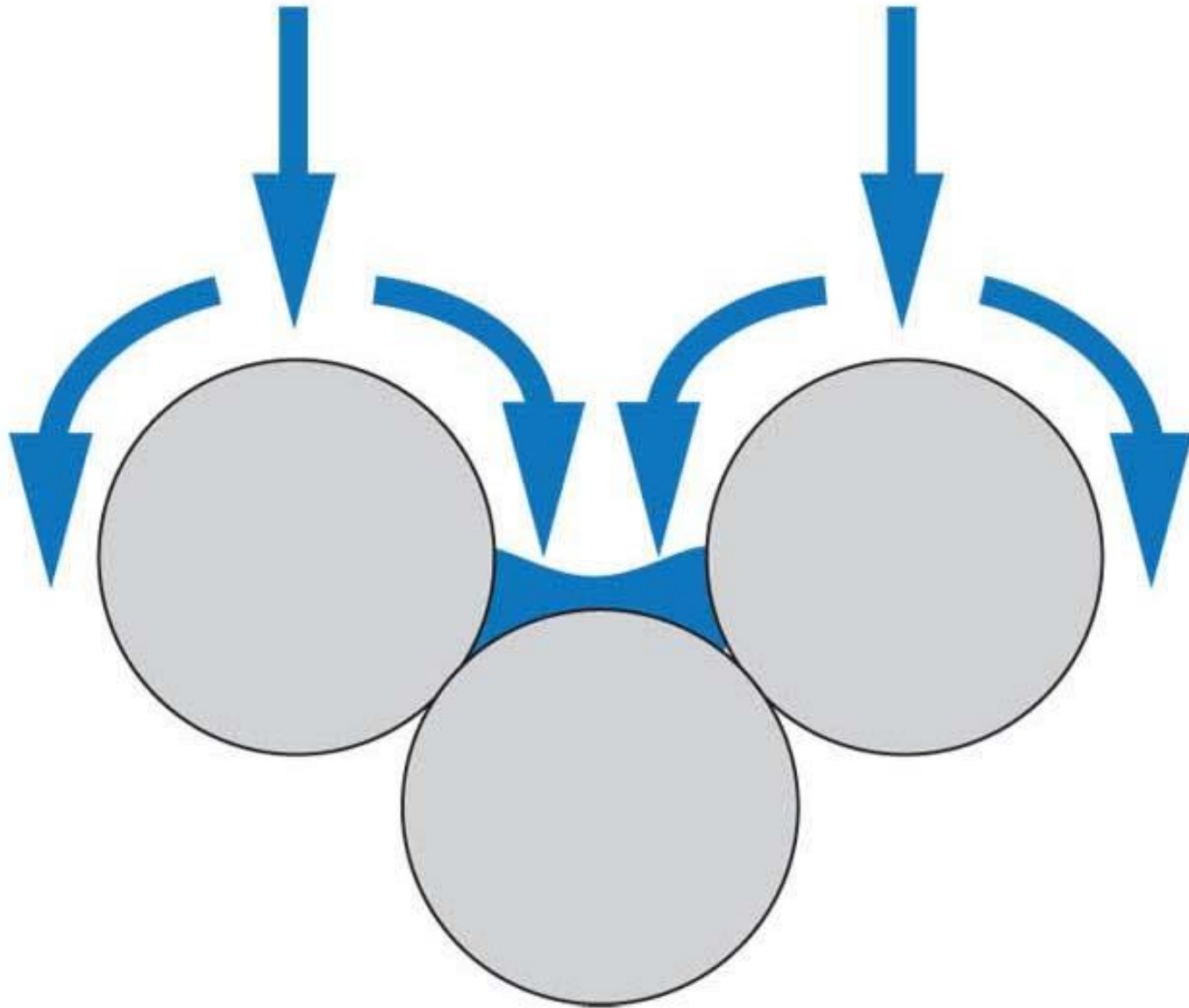


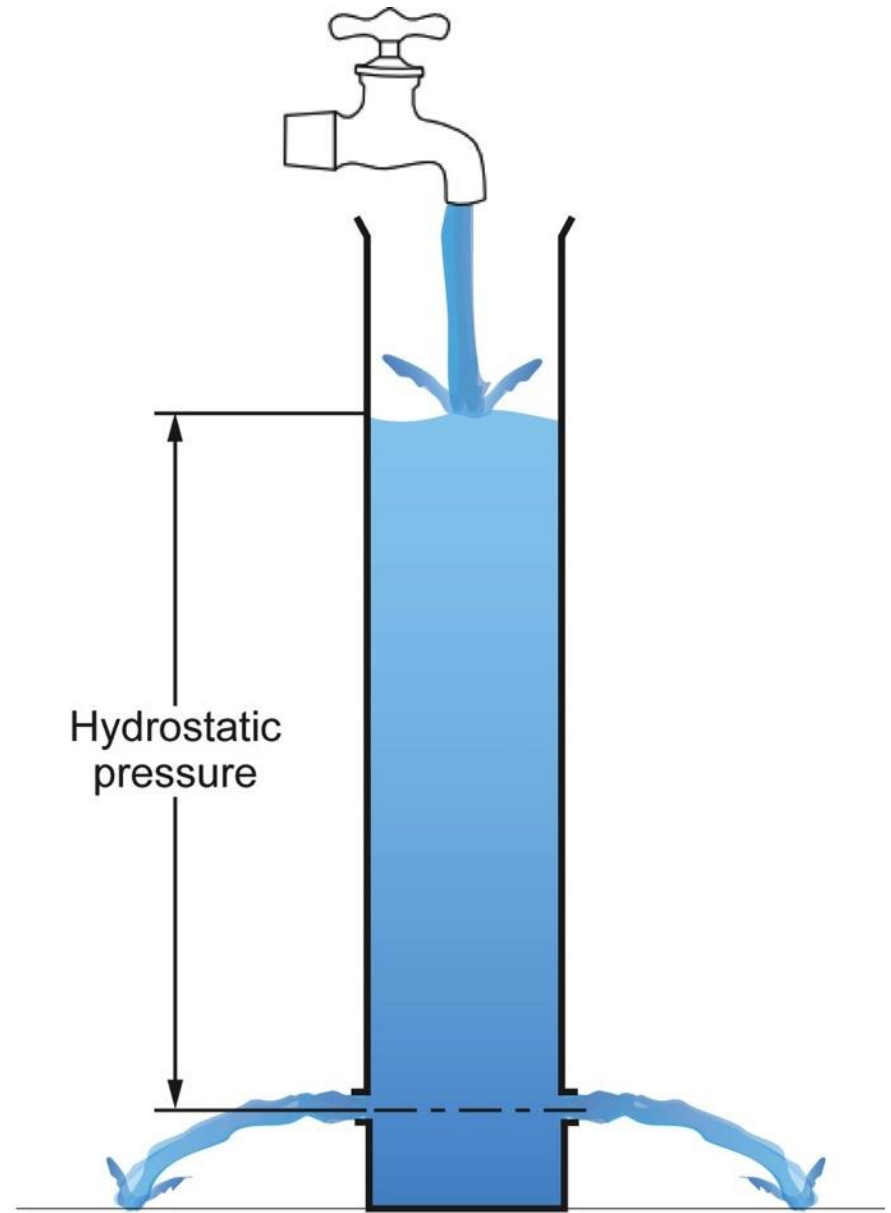
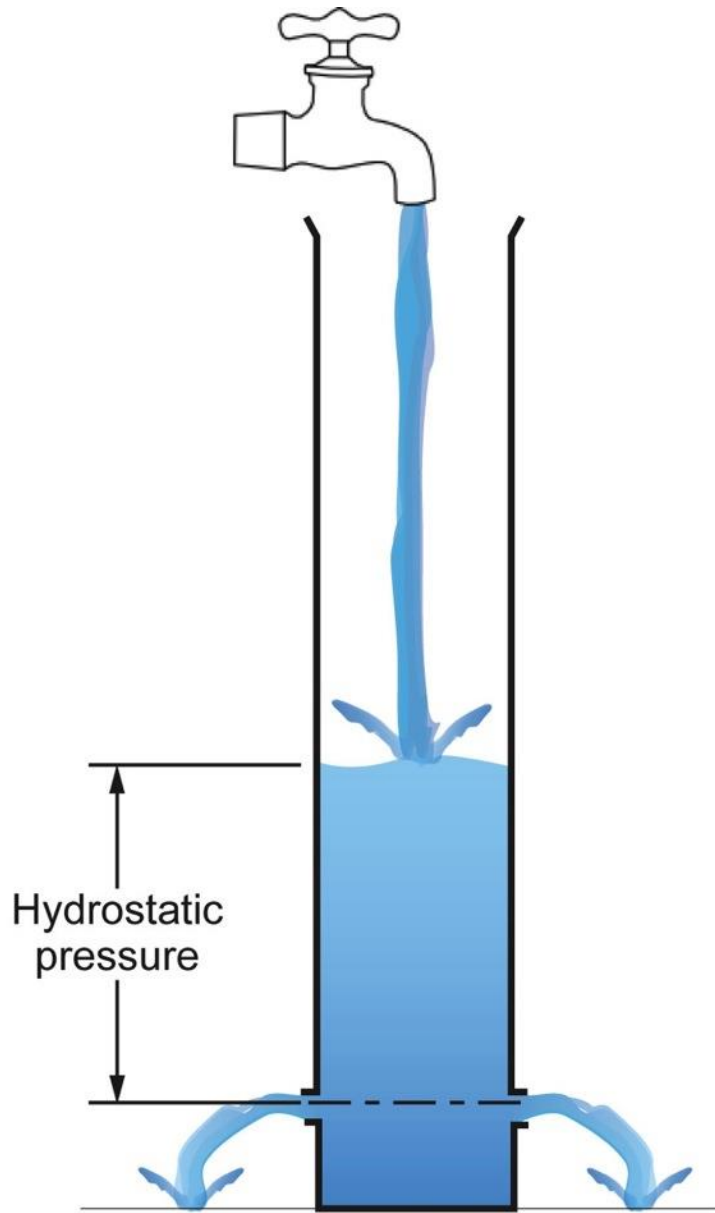


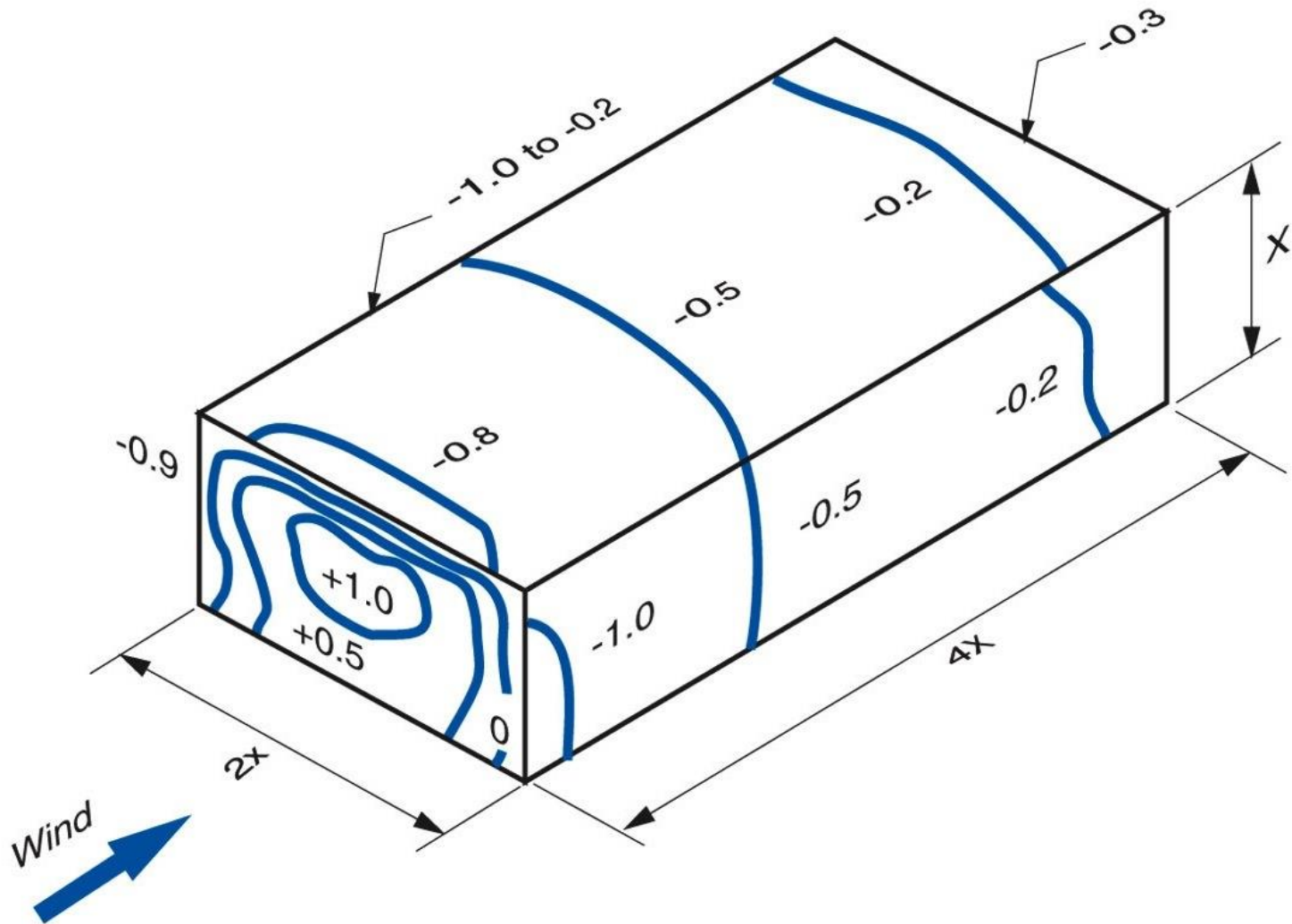








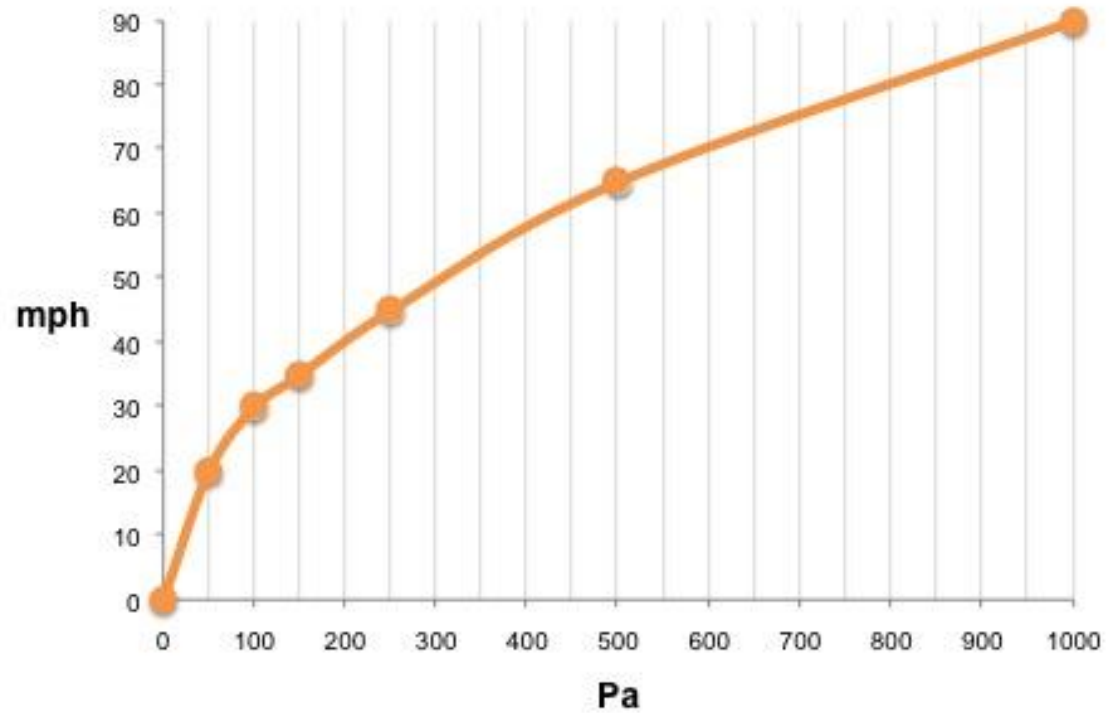




Pascals mph

50	Pa =	20	mph
100	Pa =	30	mph
150	Pa =	35	mph
250	Pa =	45	mph
500	Pa =	65	mph
1,000	Pa =	90	mph

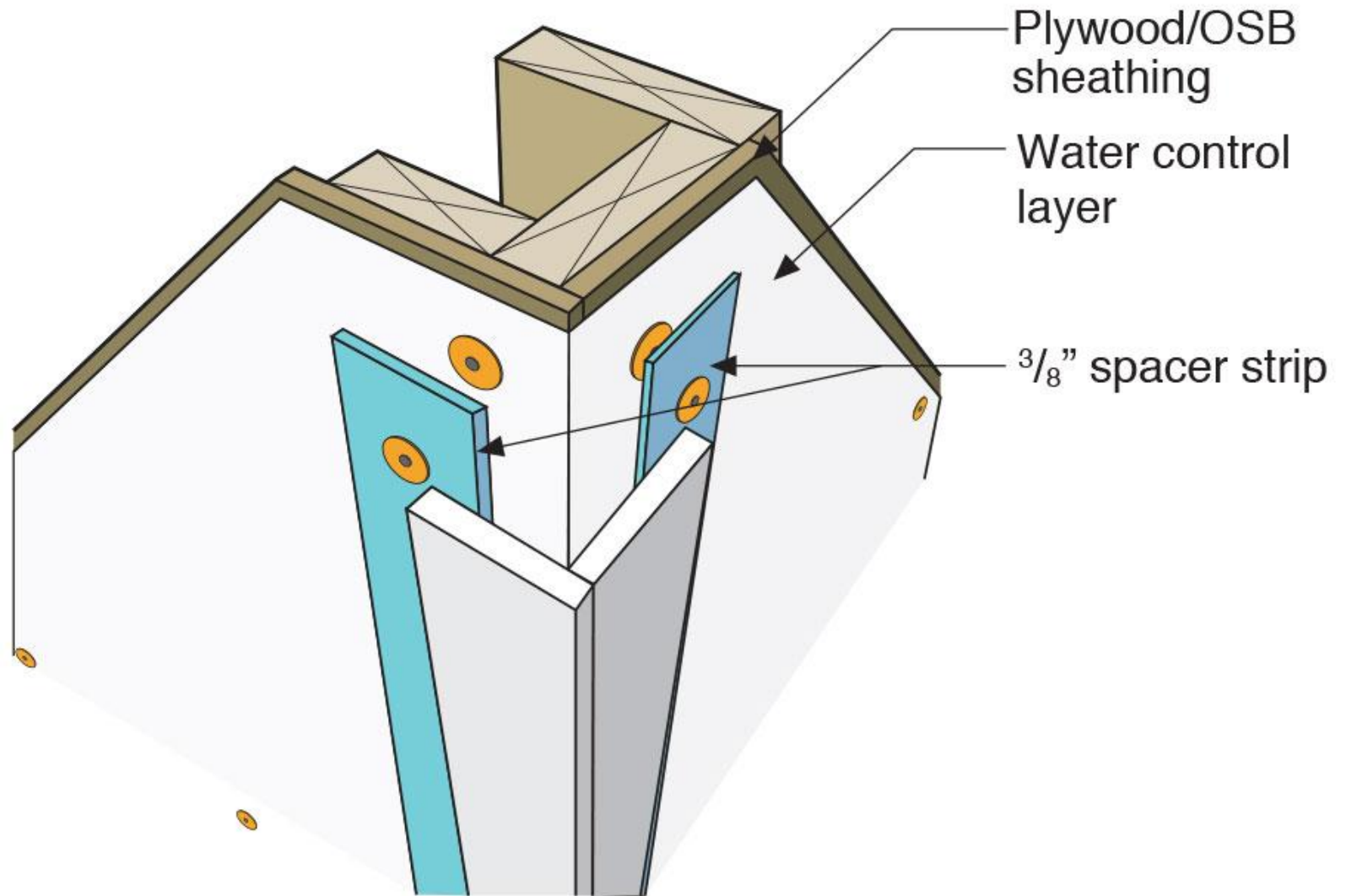
Wind Speed (mph) vs. Stagnation Pressure (Pa)



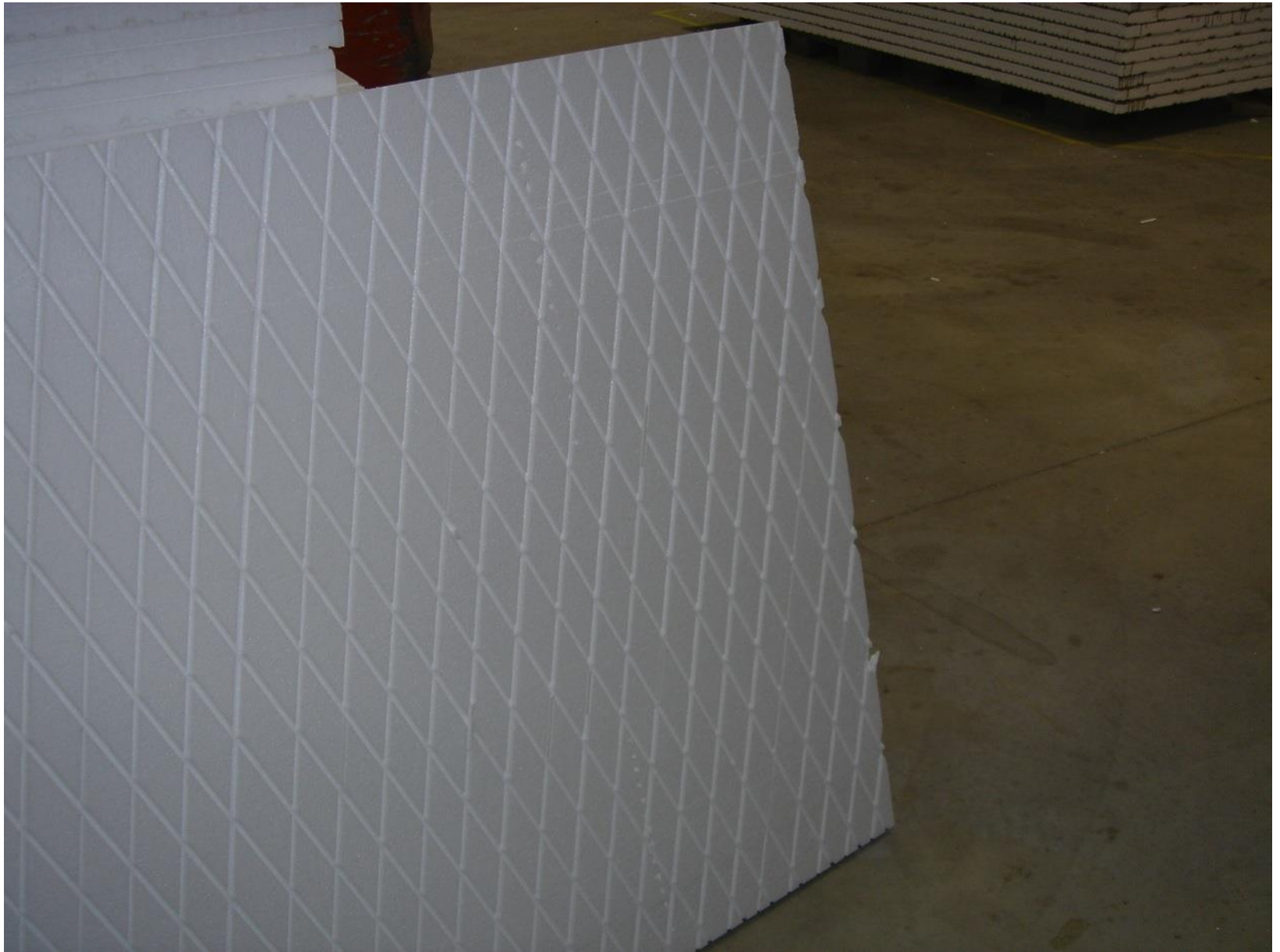




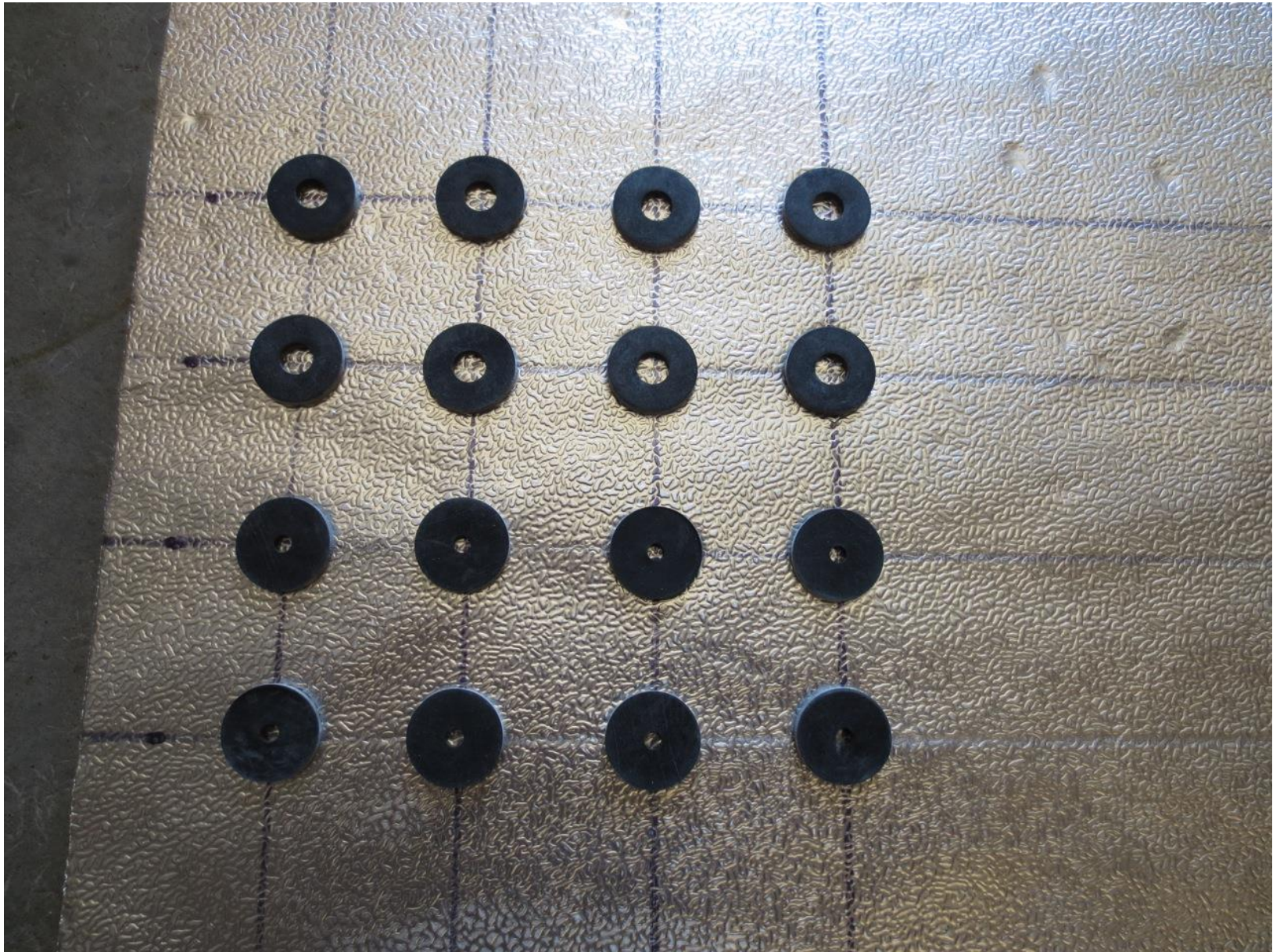




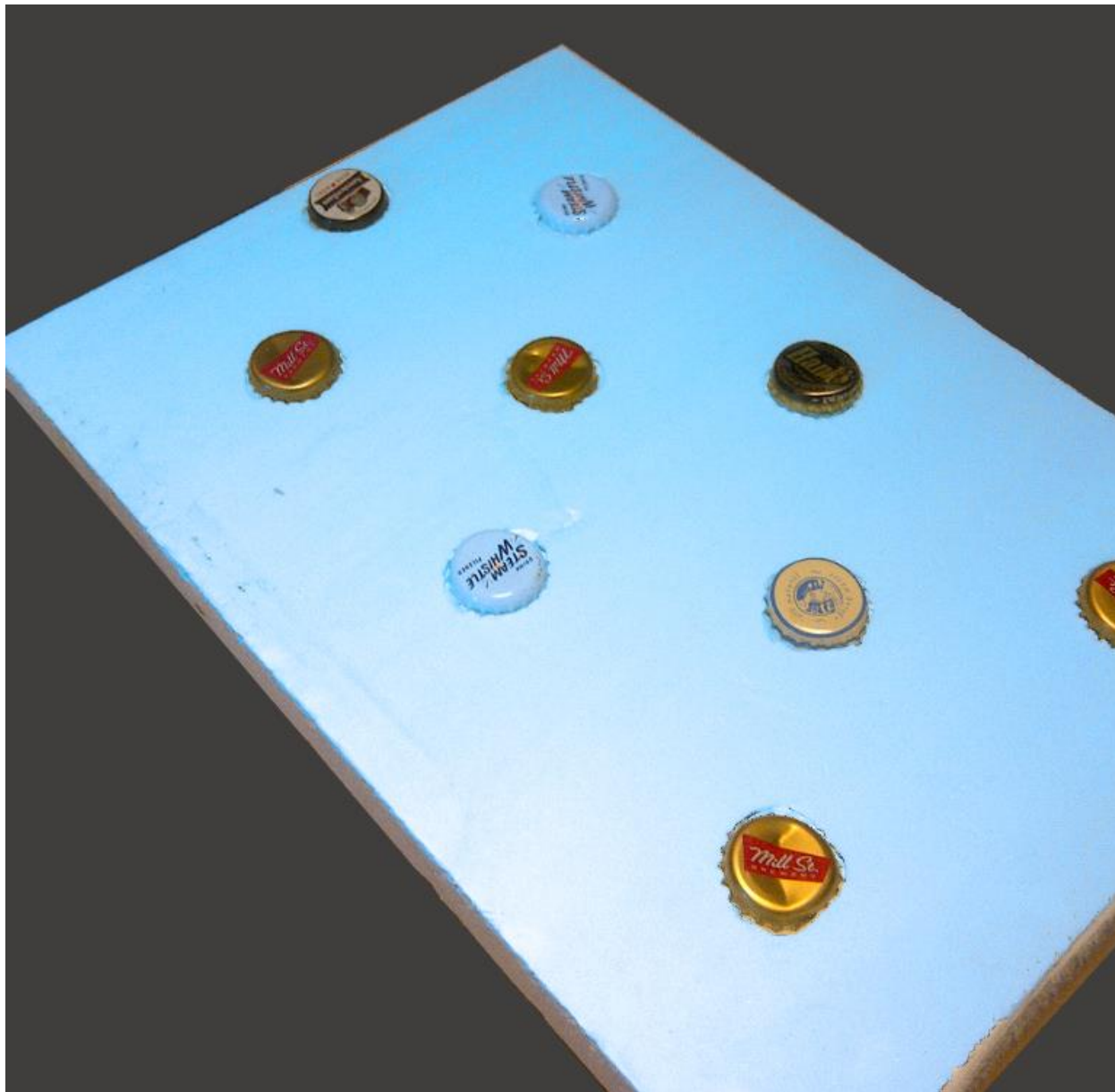


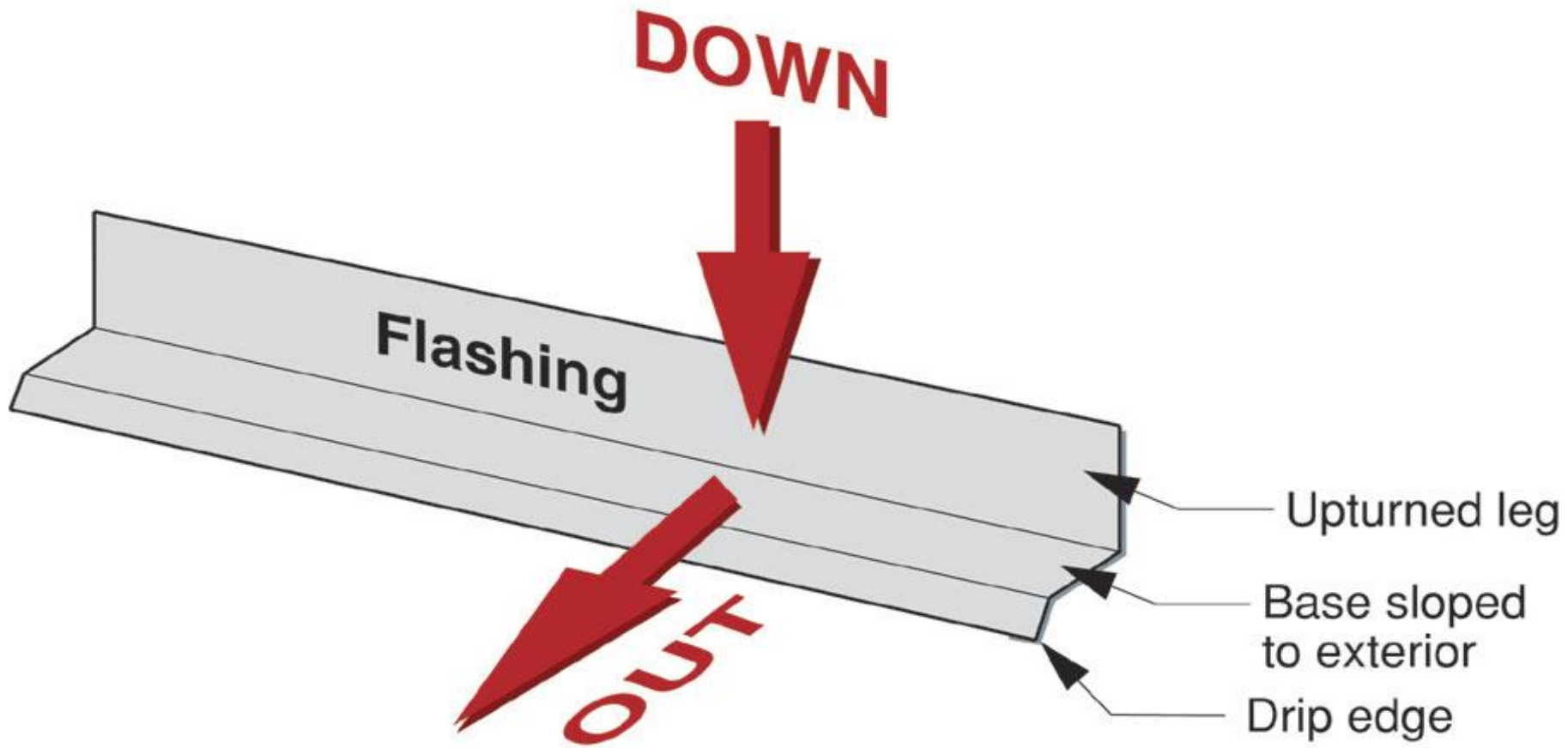


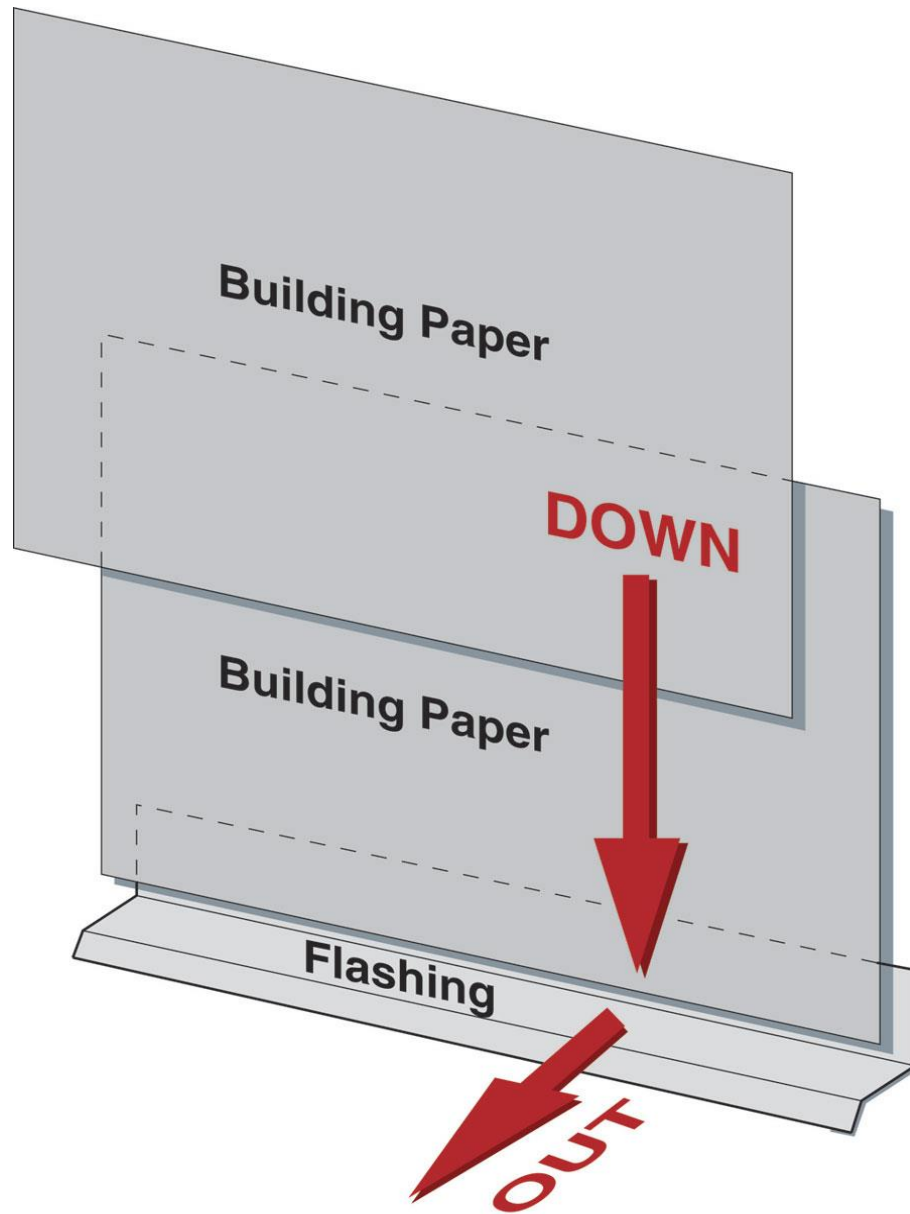
Rain Screen



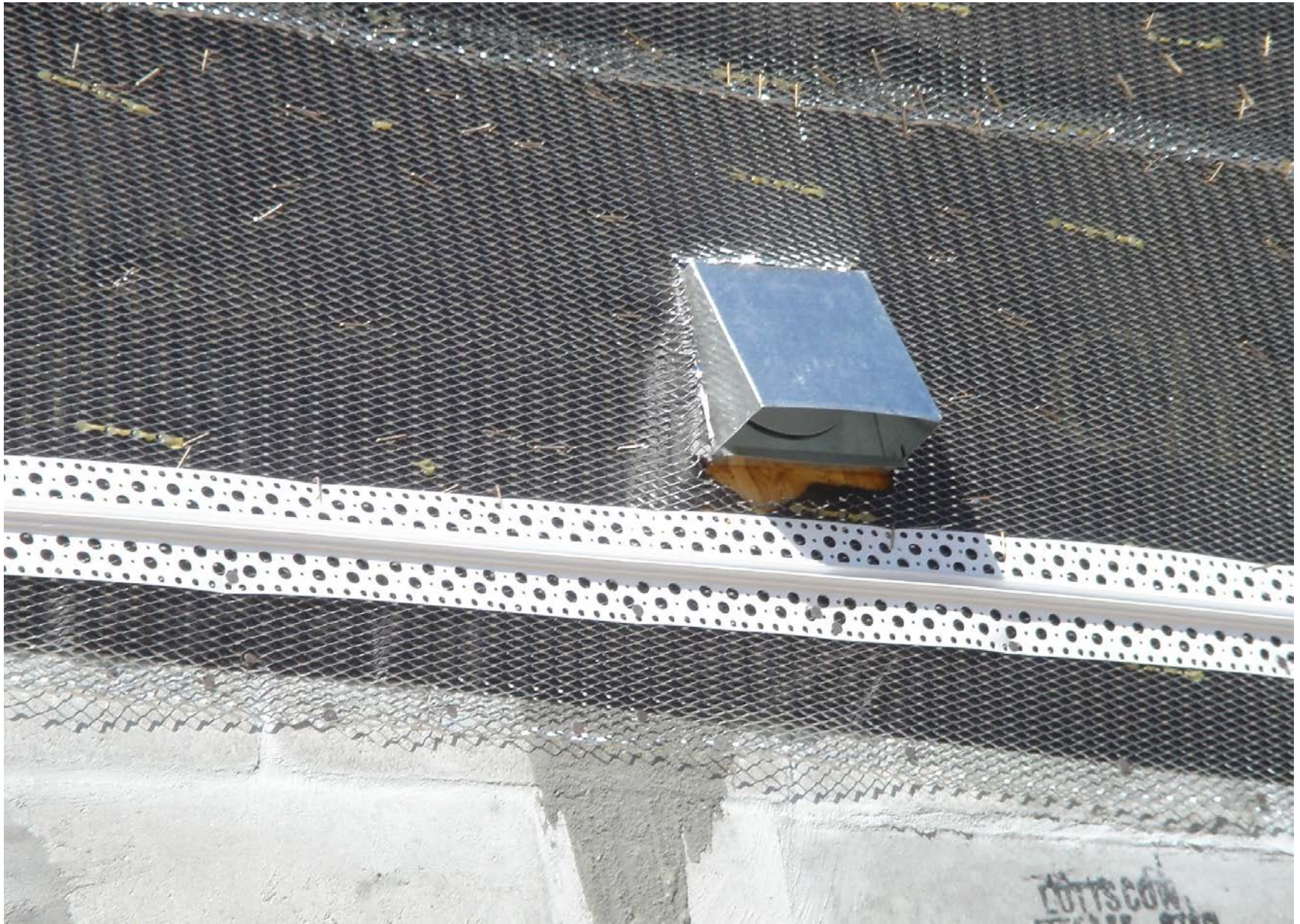
Beer Screen?

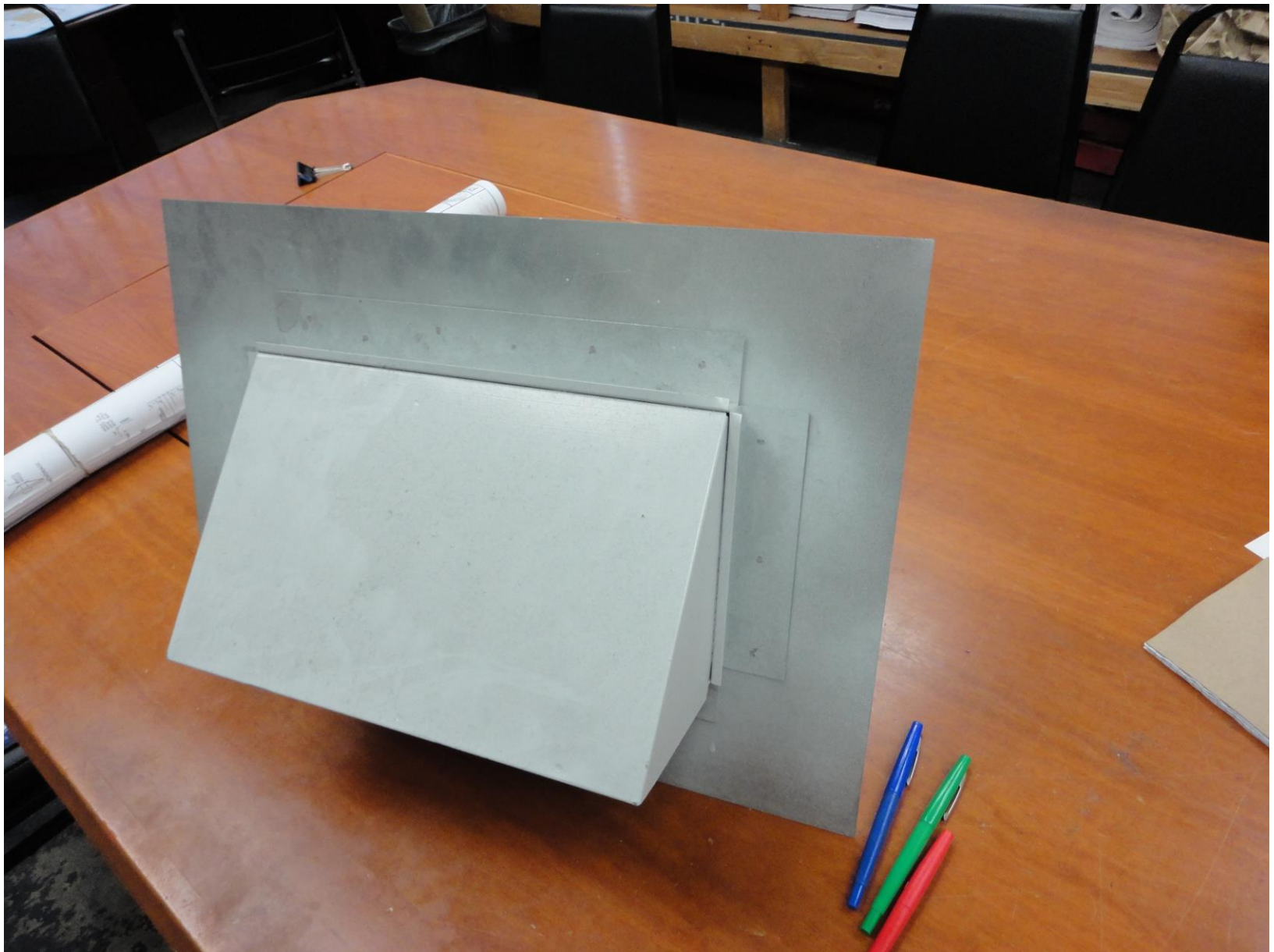








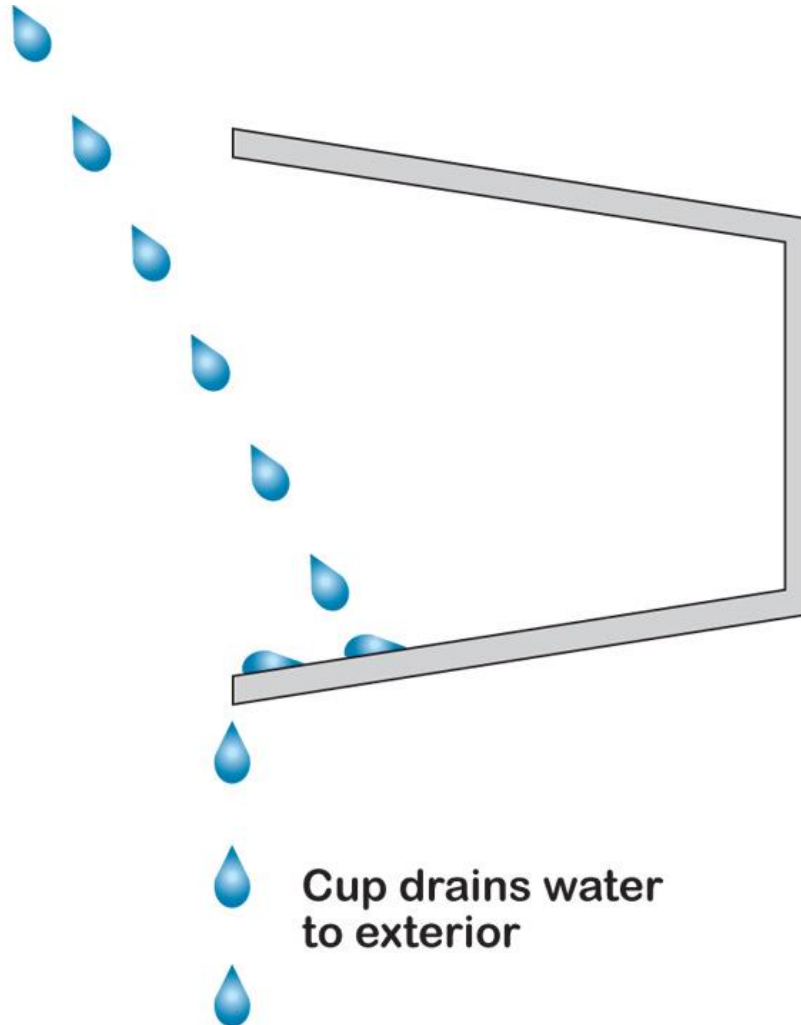








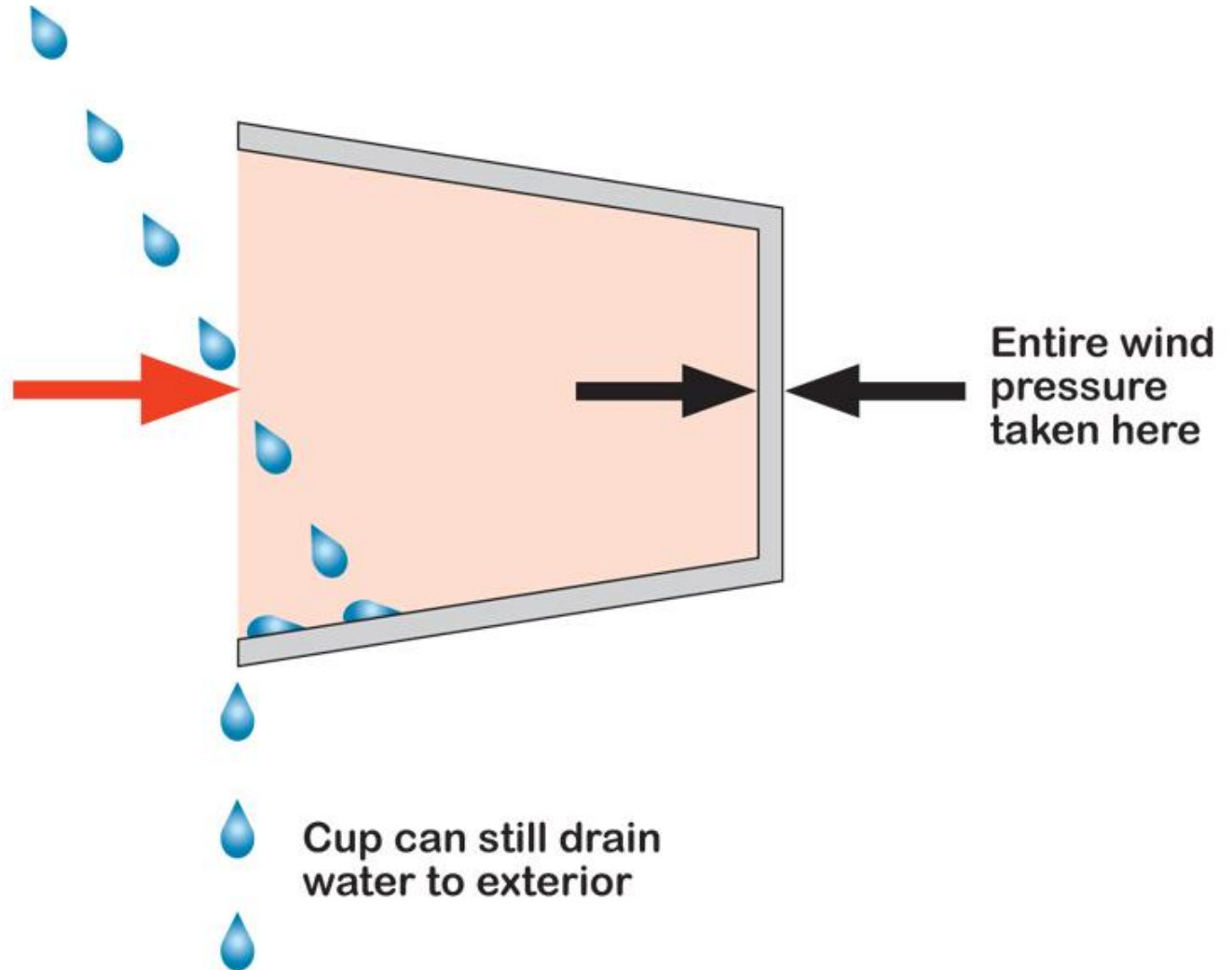
**Rain enters cup
due to momentum
("kinetic energy")**

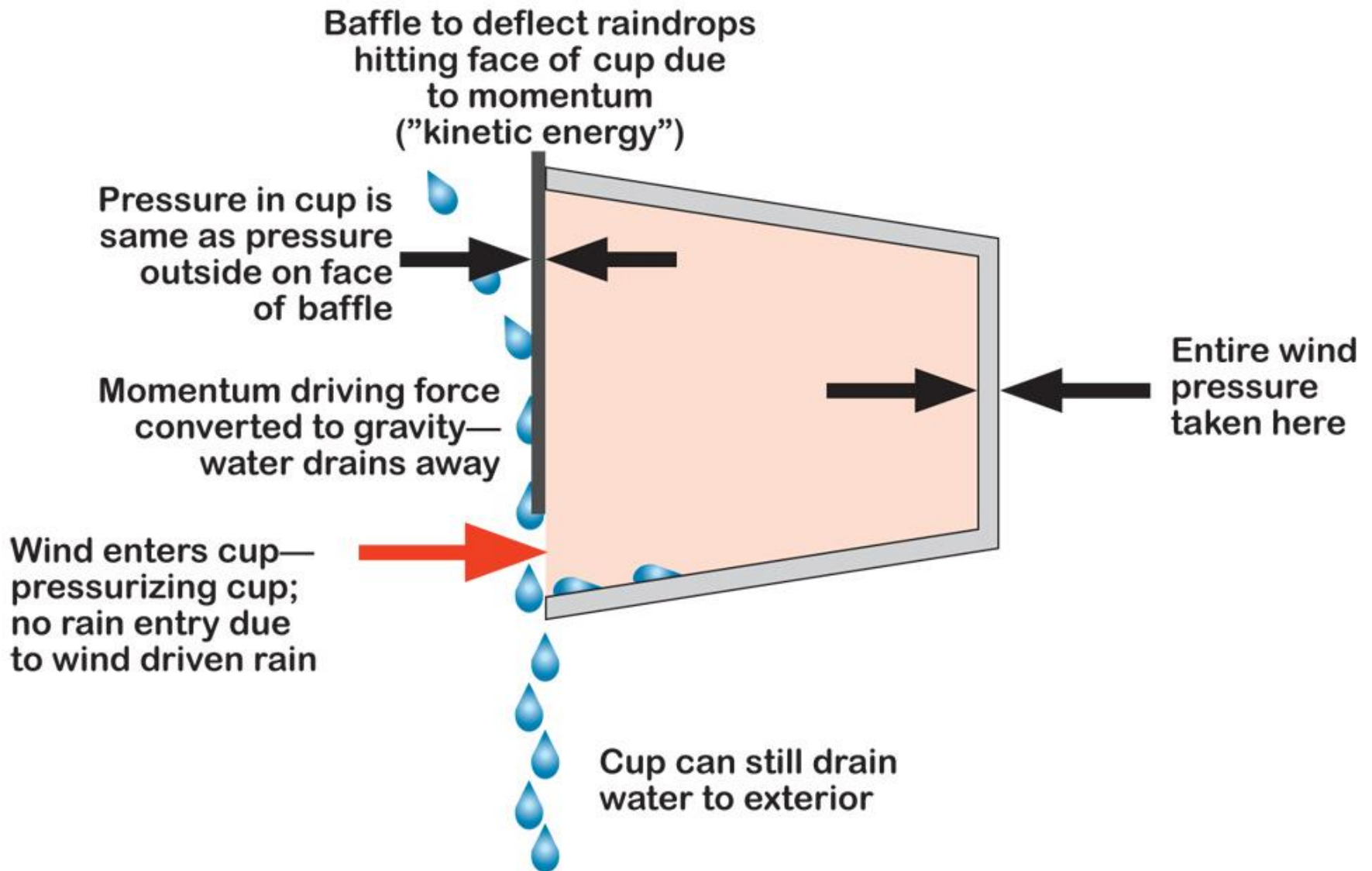


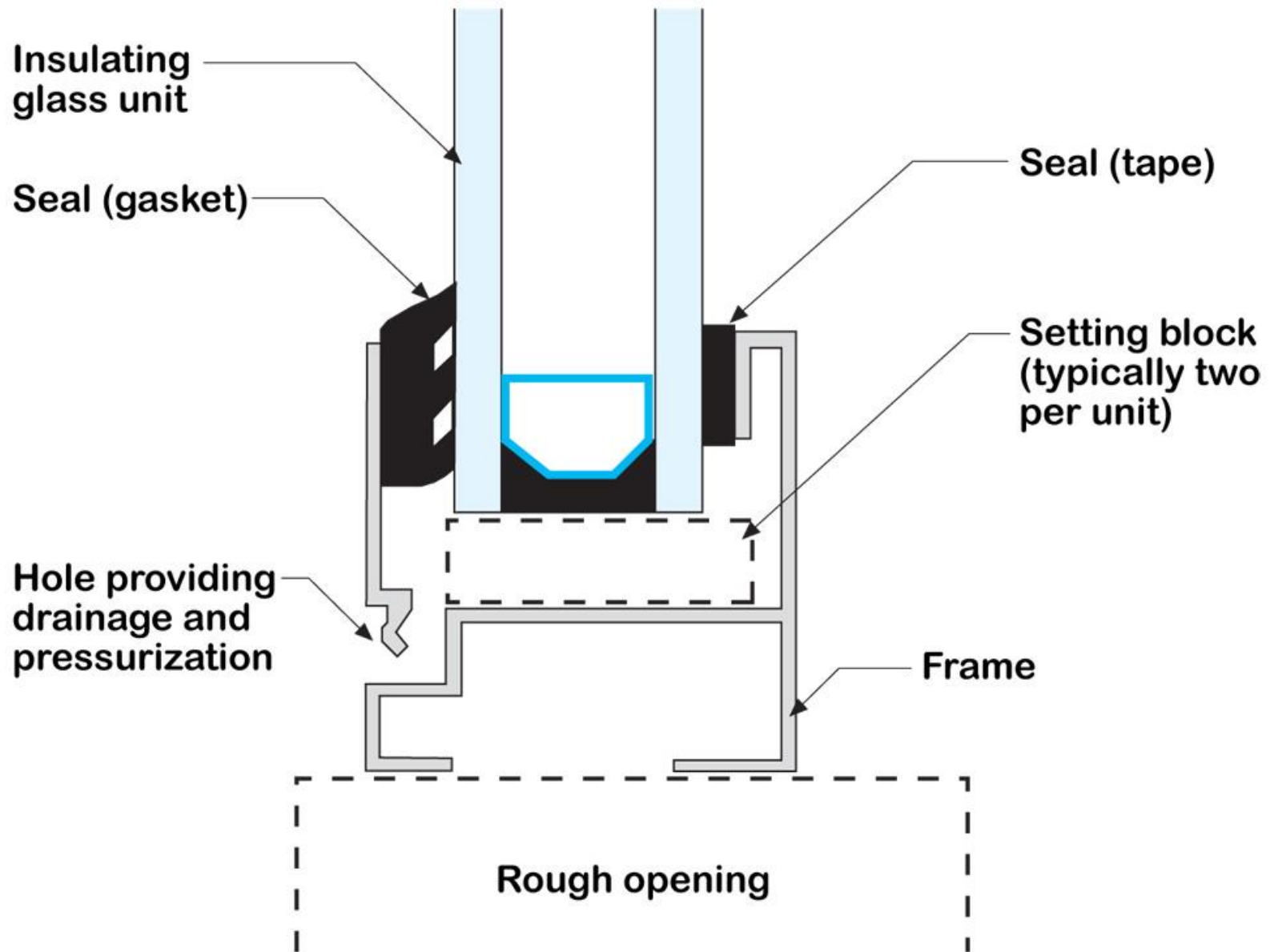
**Cup drains water
to exterior**

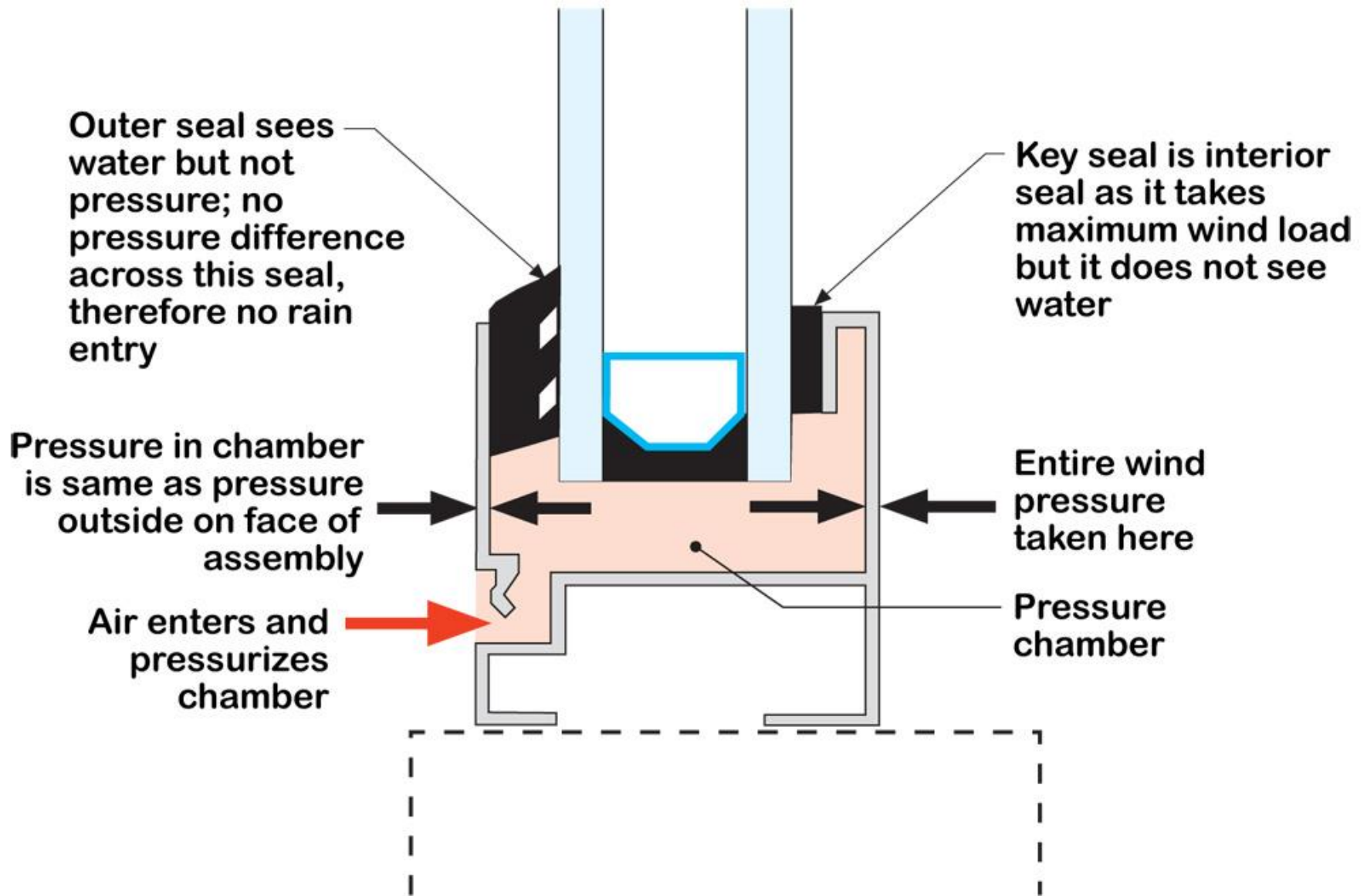
Rain enters cup due to momentum ("kinetic energy")

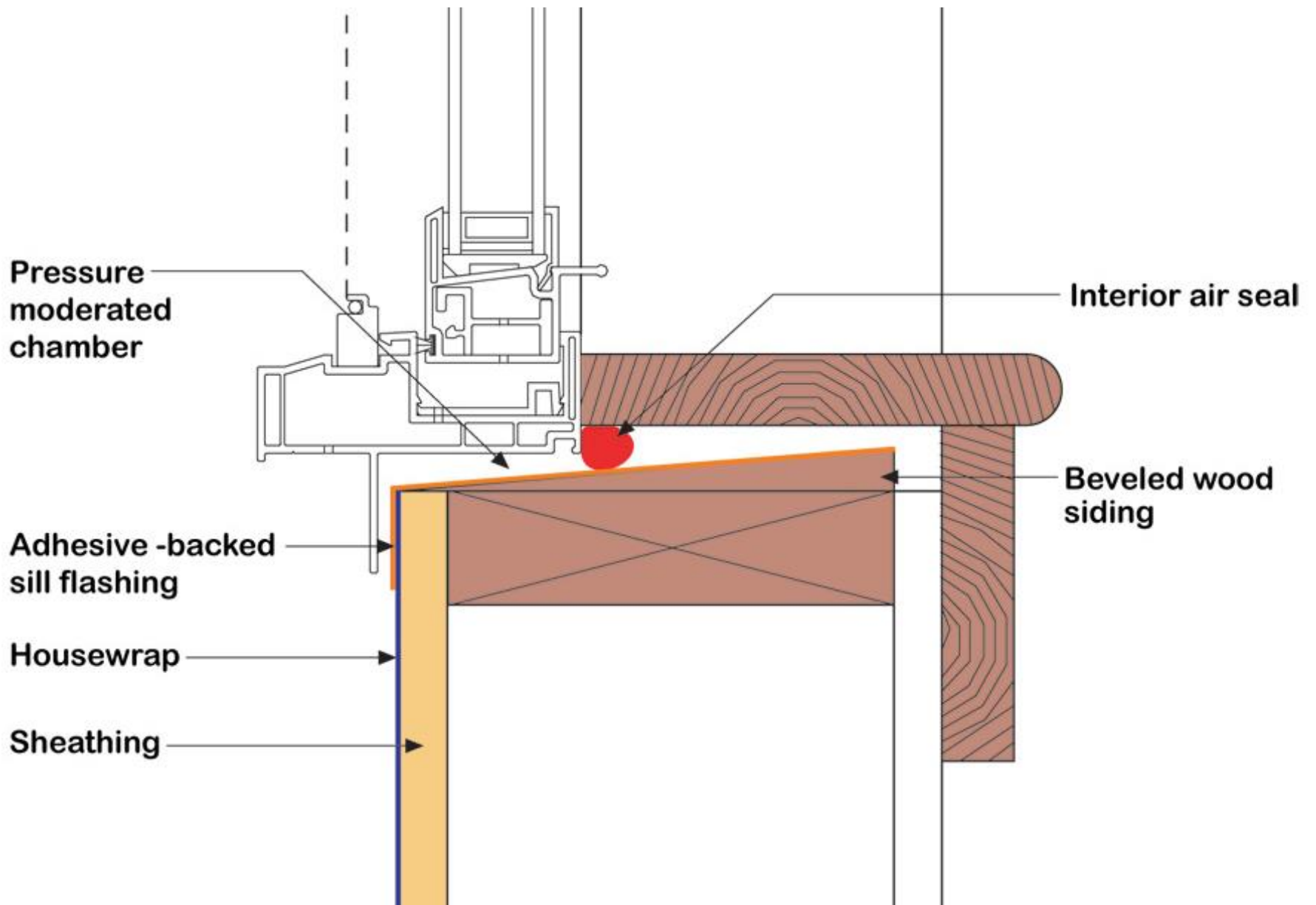
Wind enters cup—pressurizing cup; no rain entry due to wind driven rain





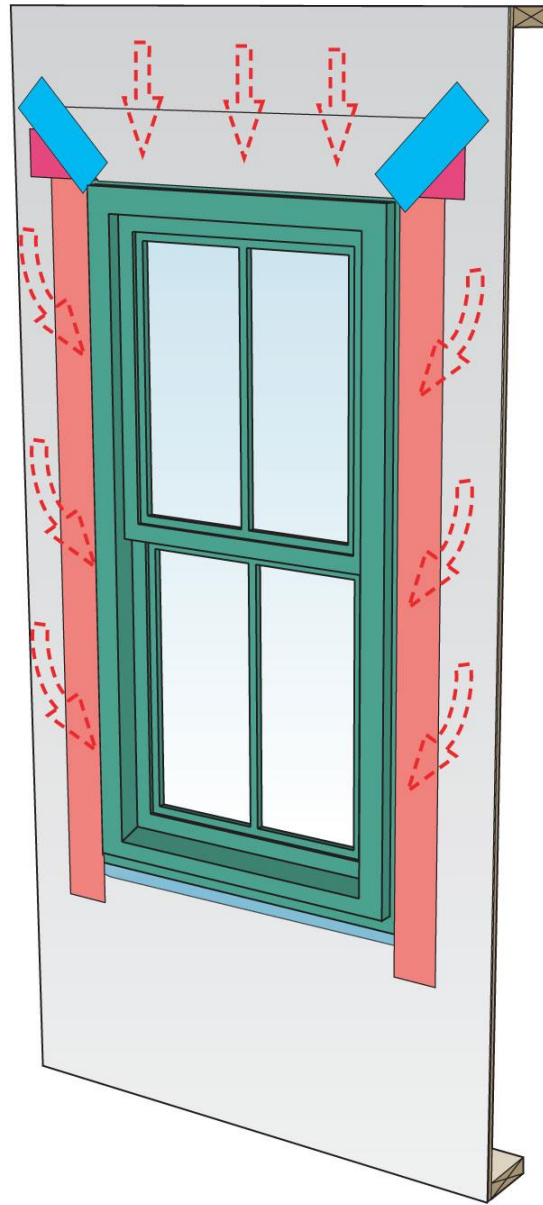


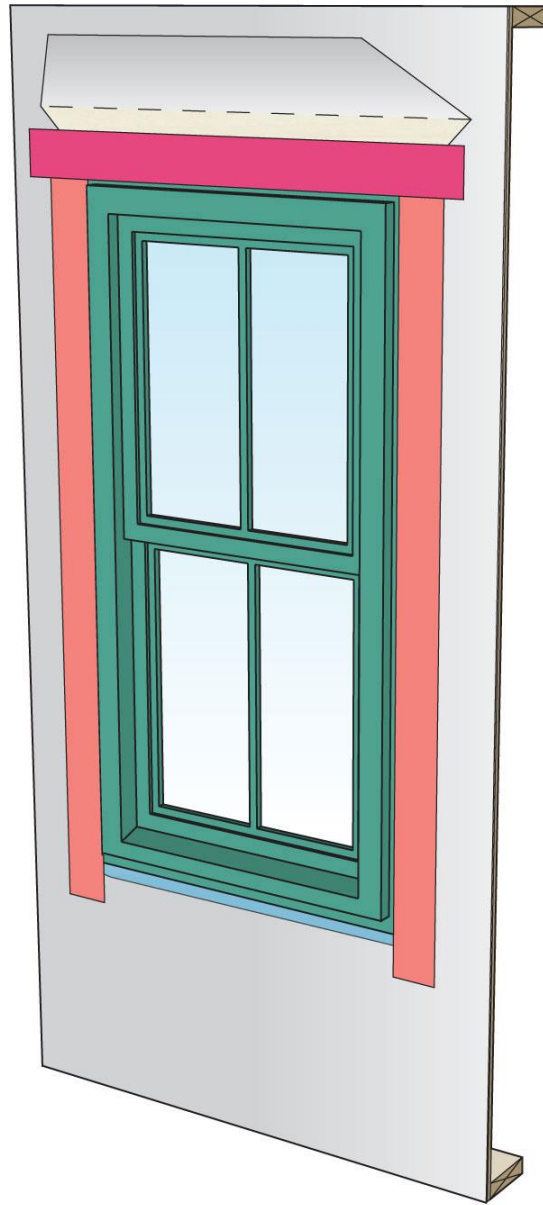




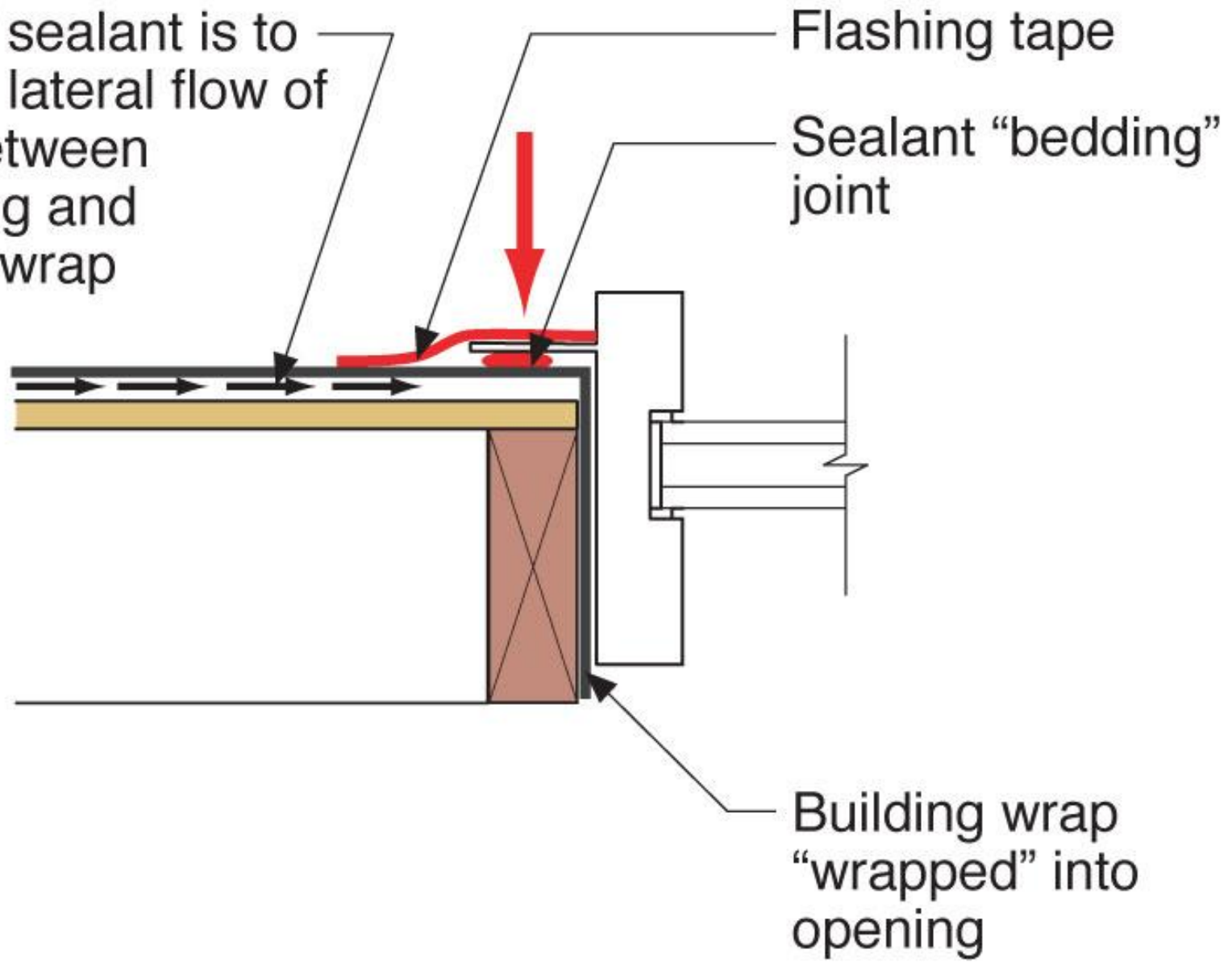


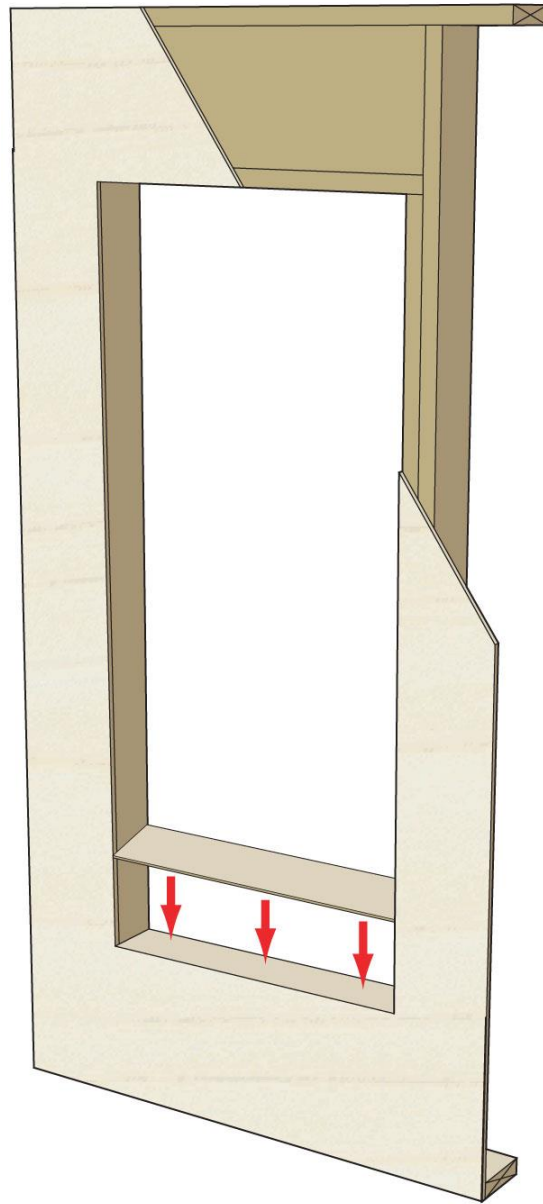


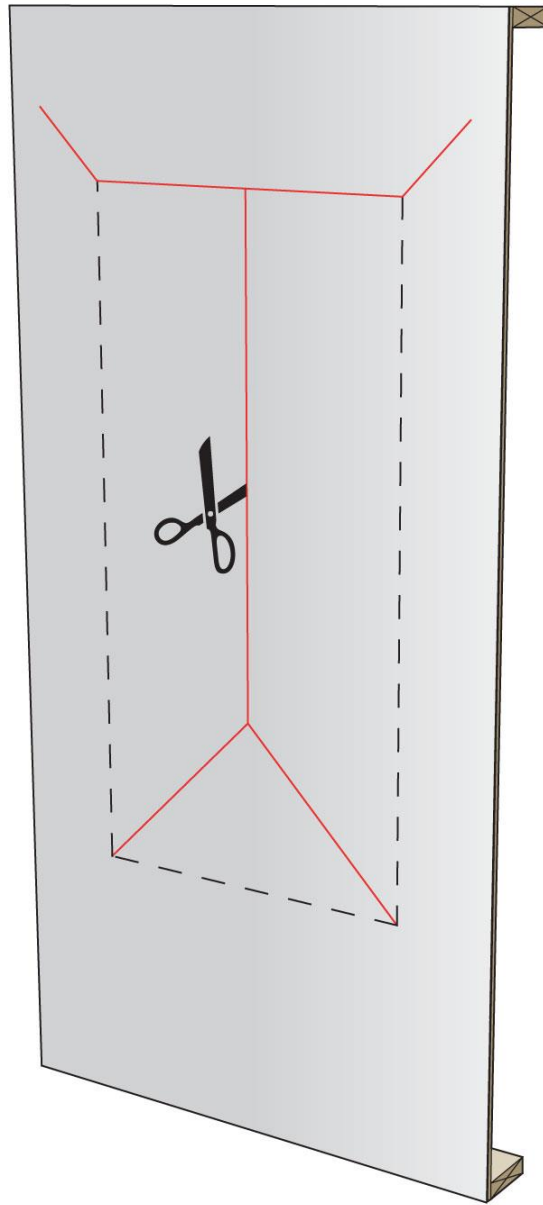


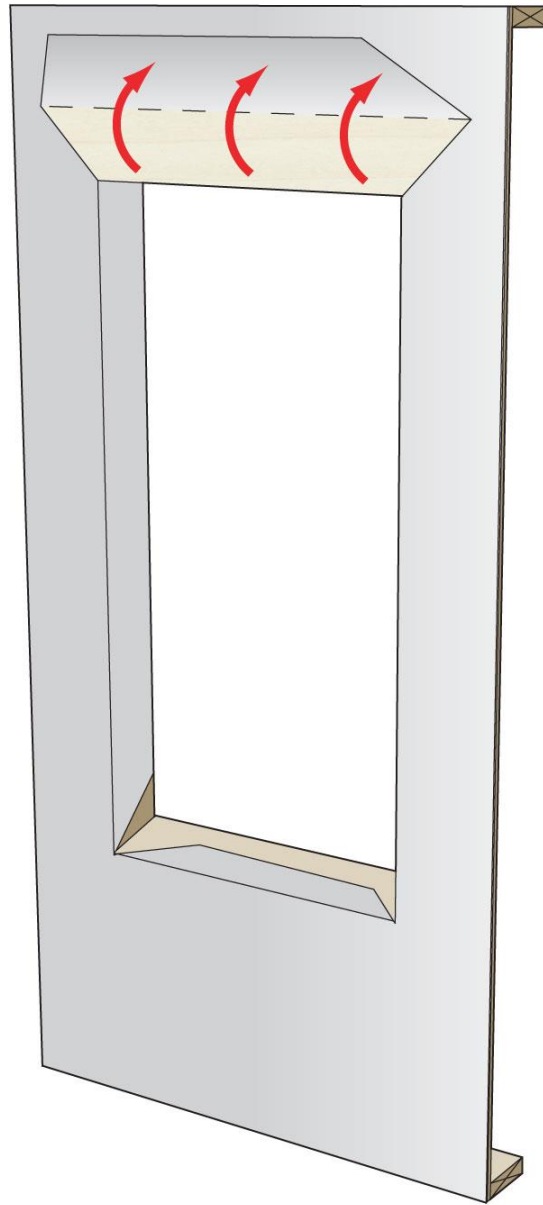


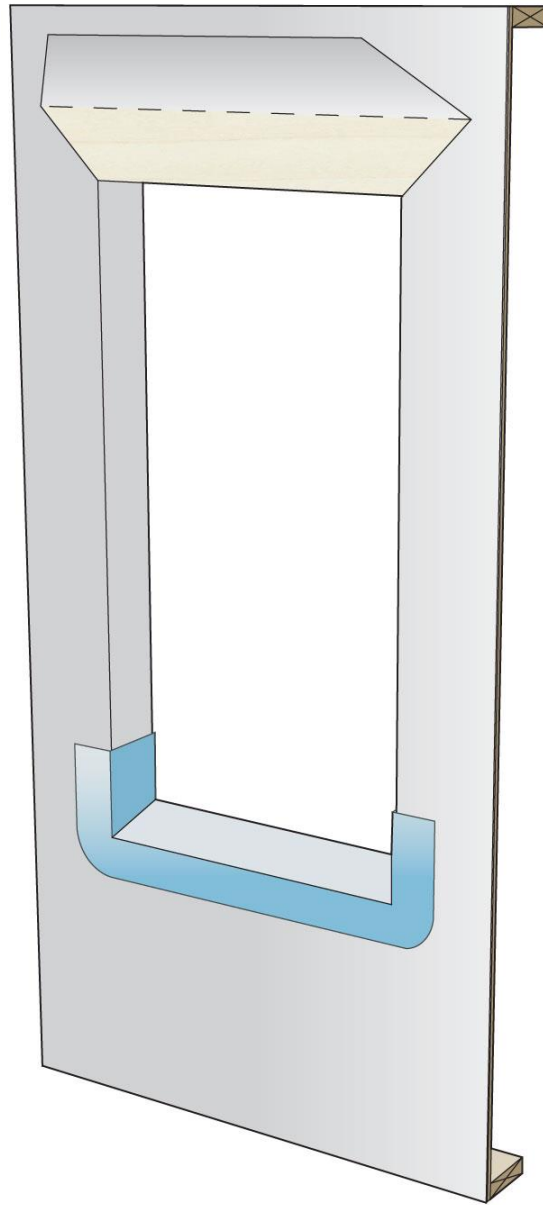
Intent of sealant is to limit this lateral flow of water between sheathing and building wrap

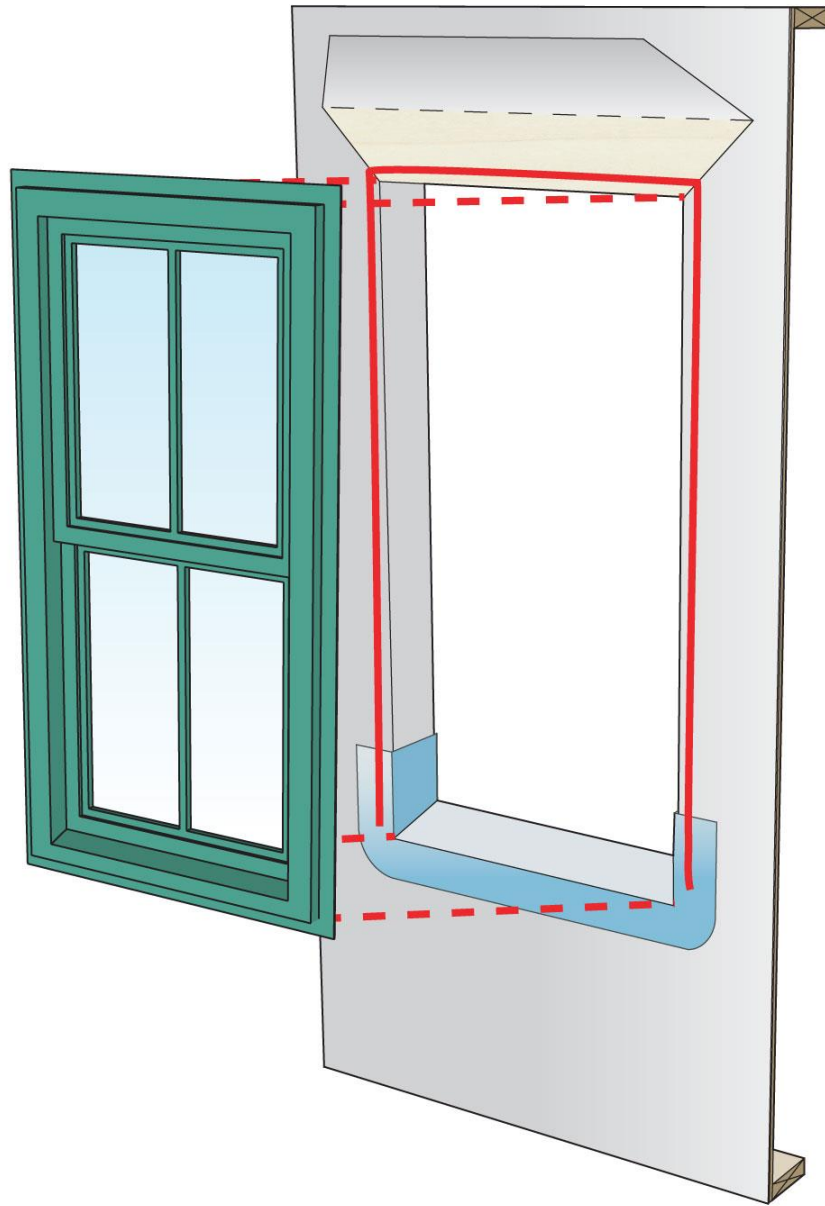


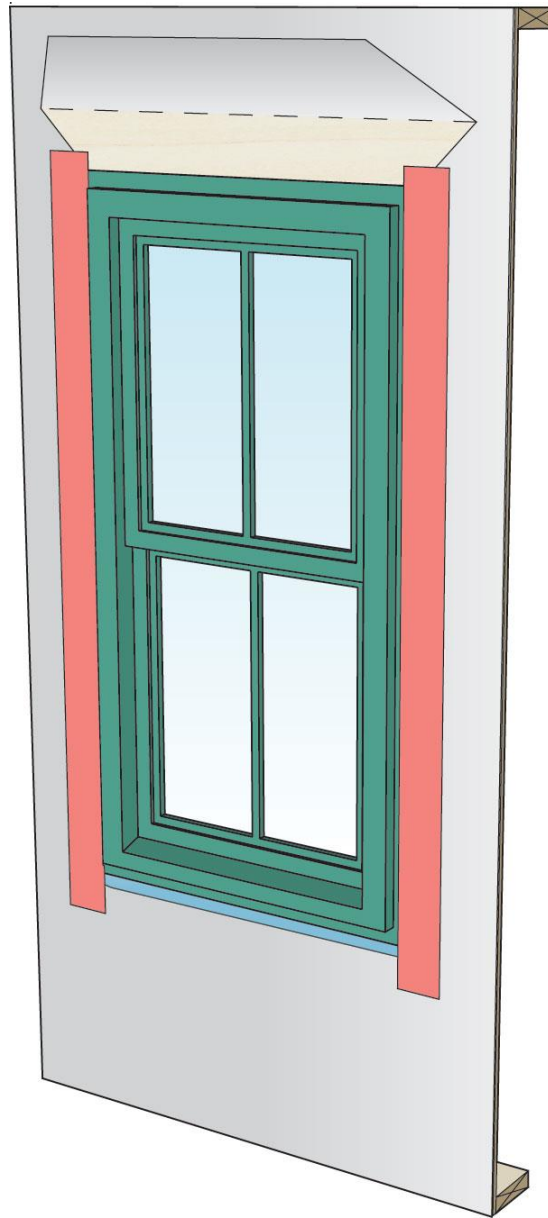


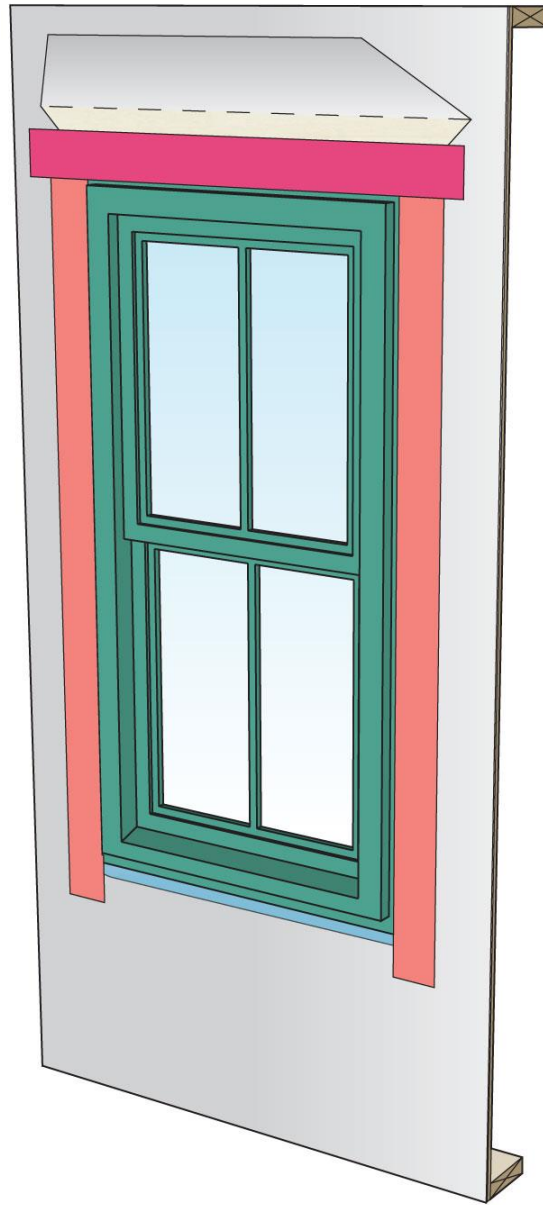


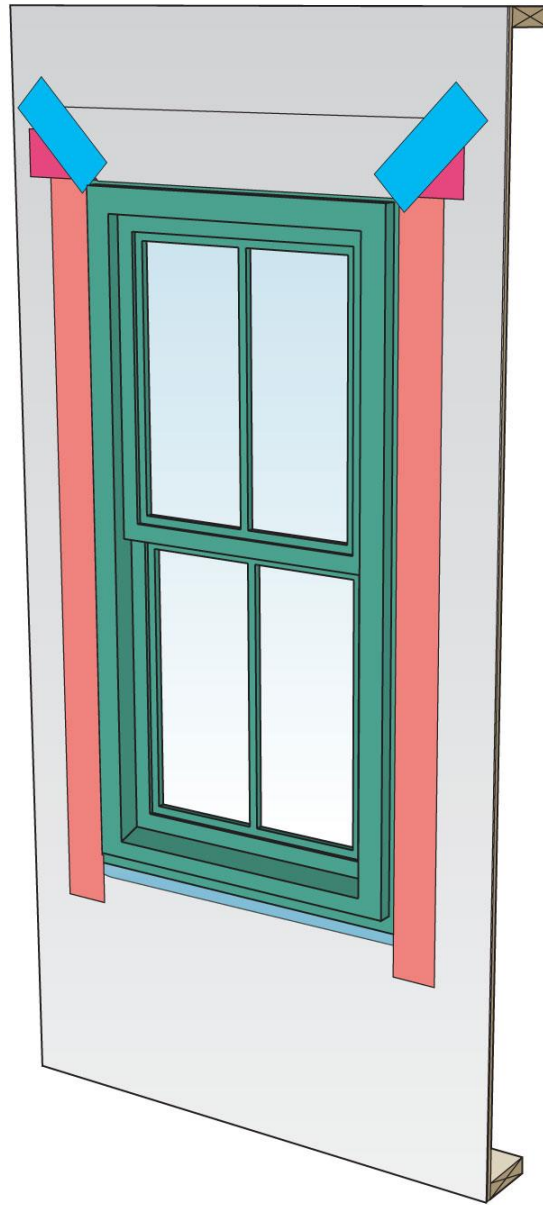


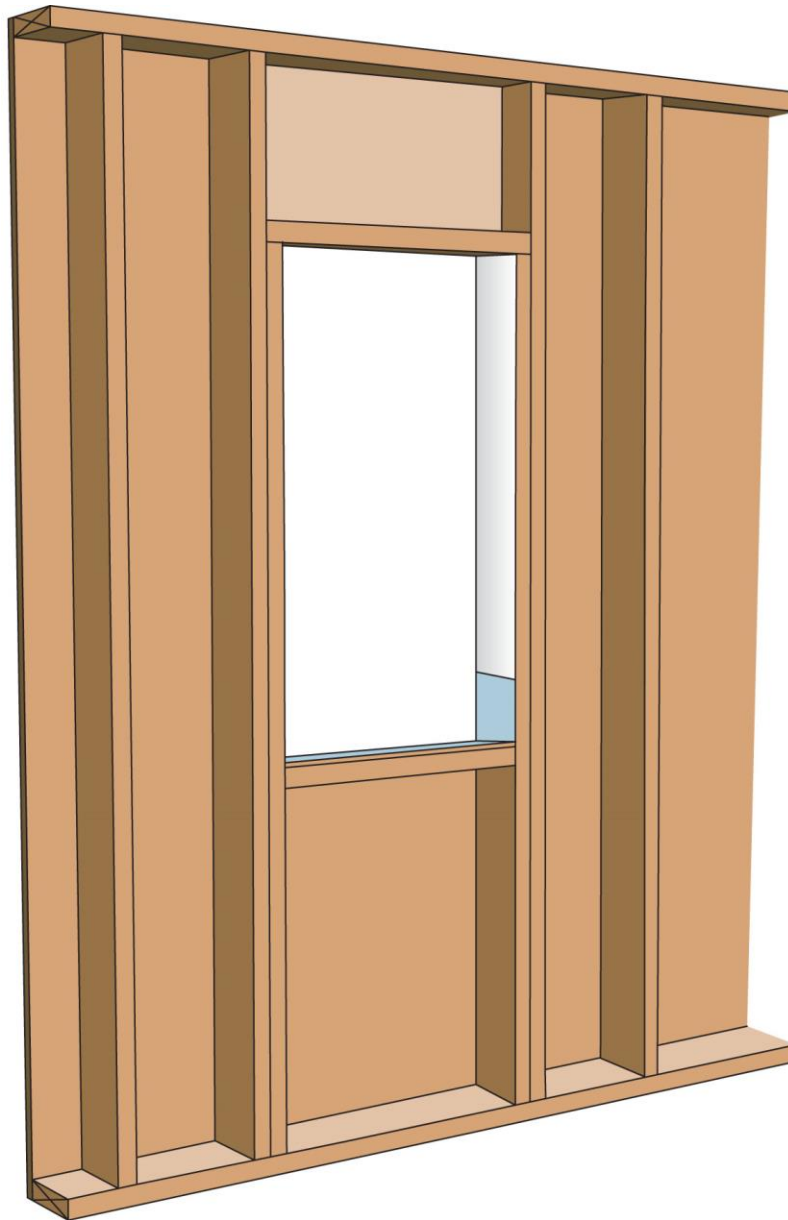




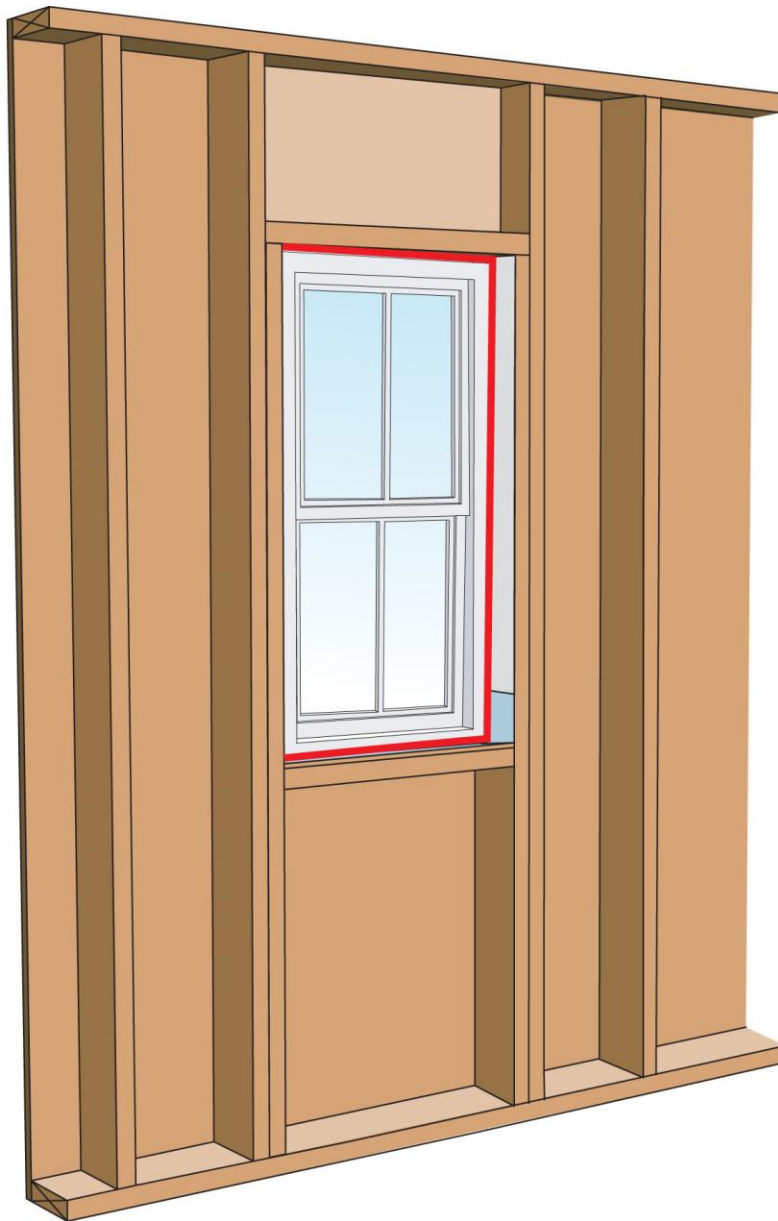


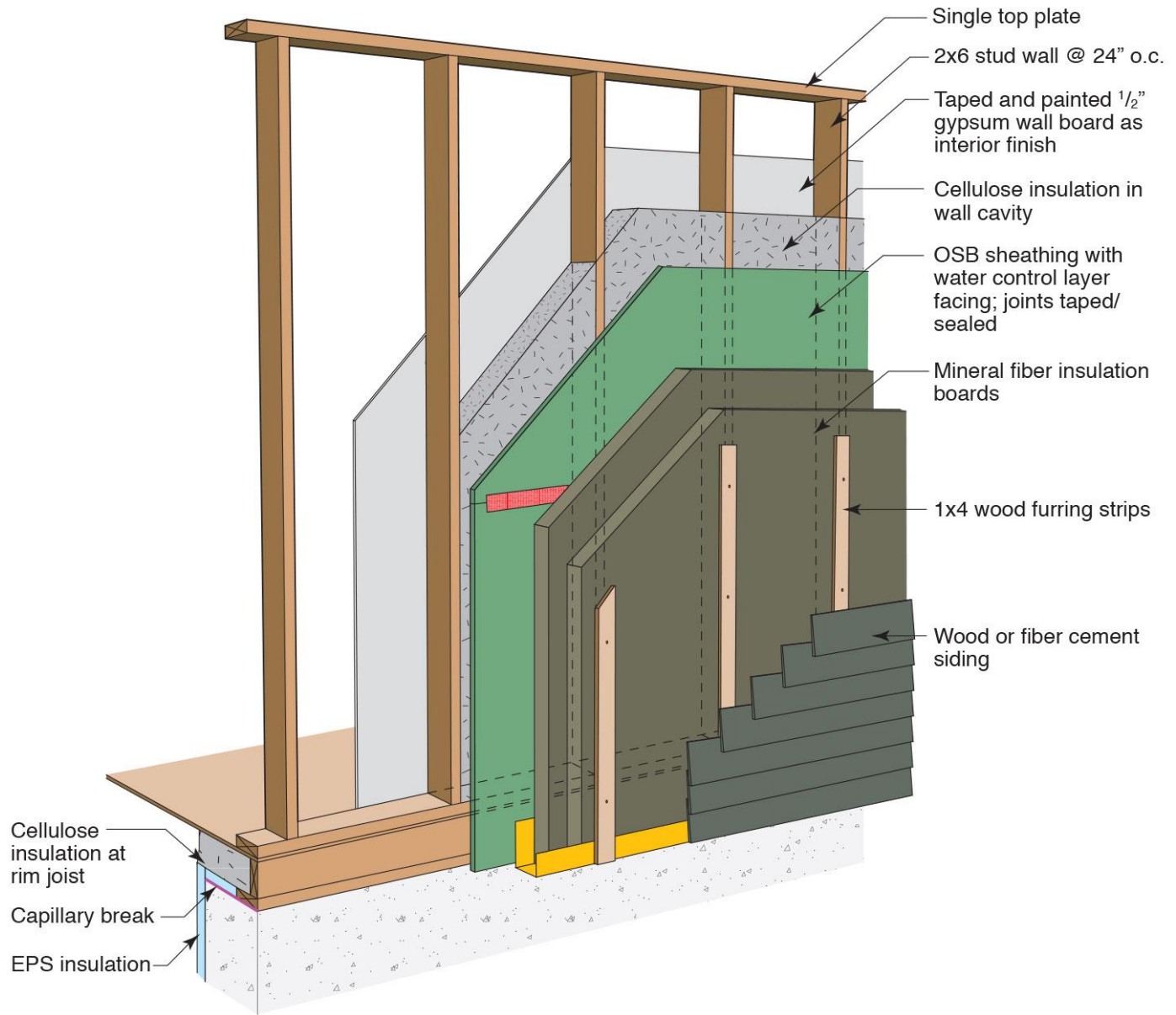


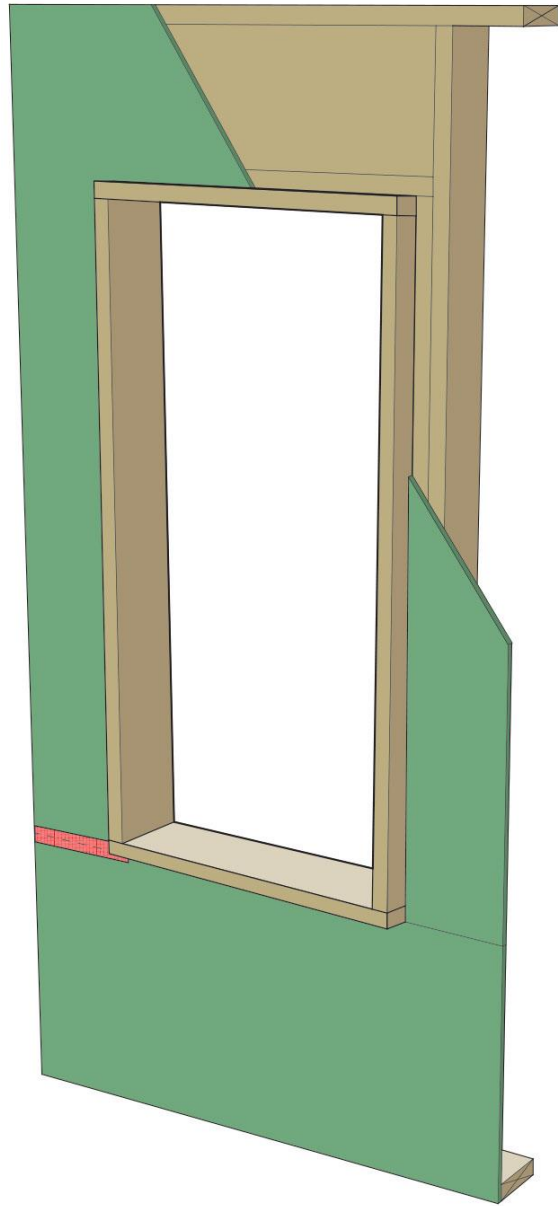


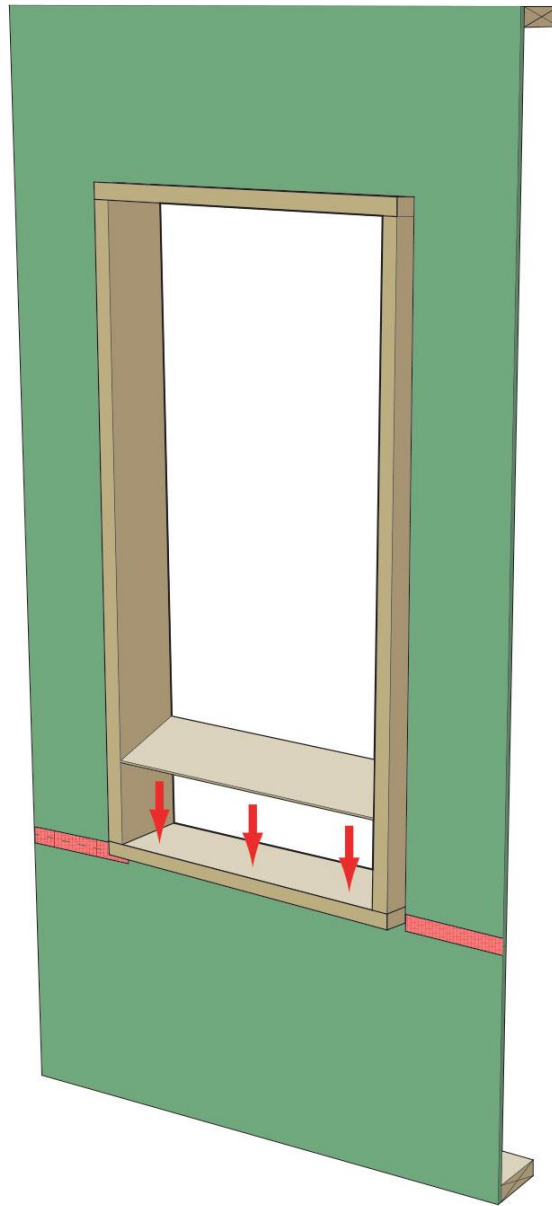


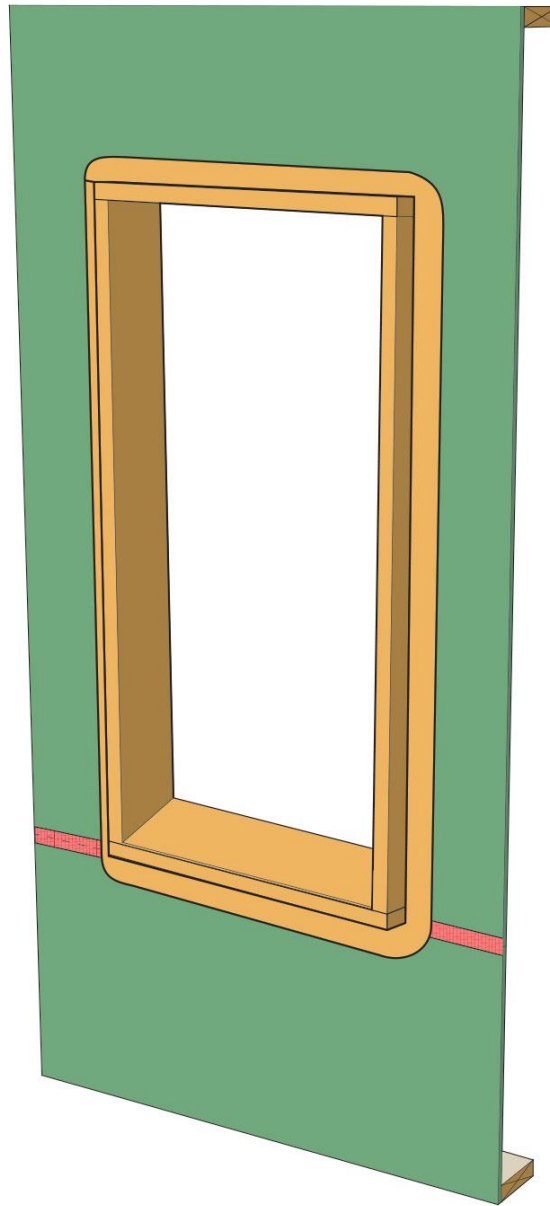


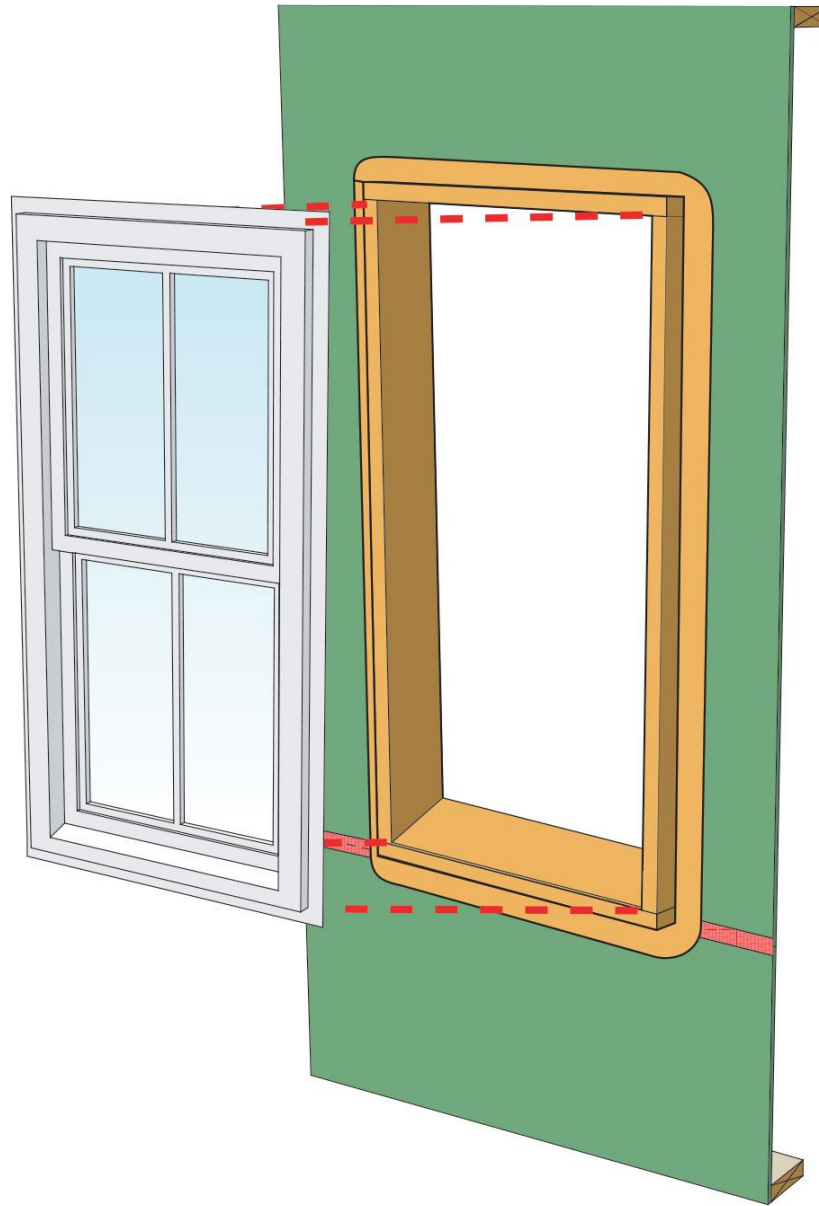


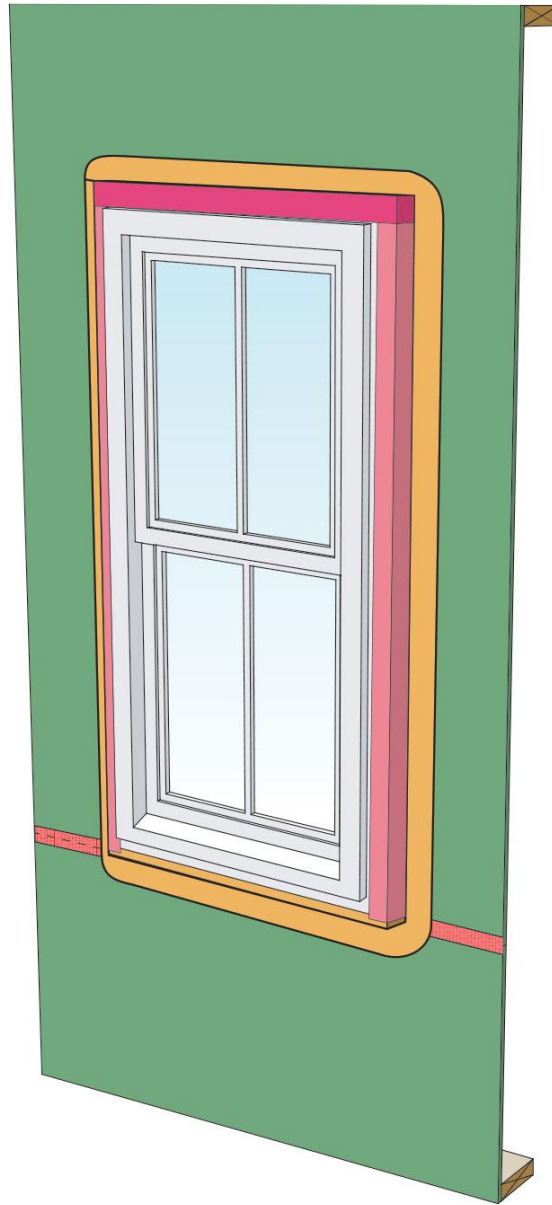


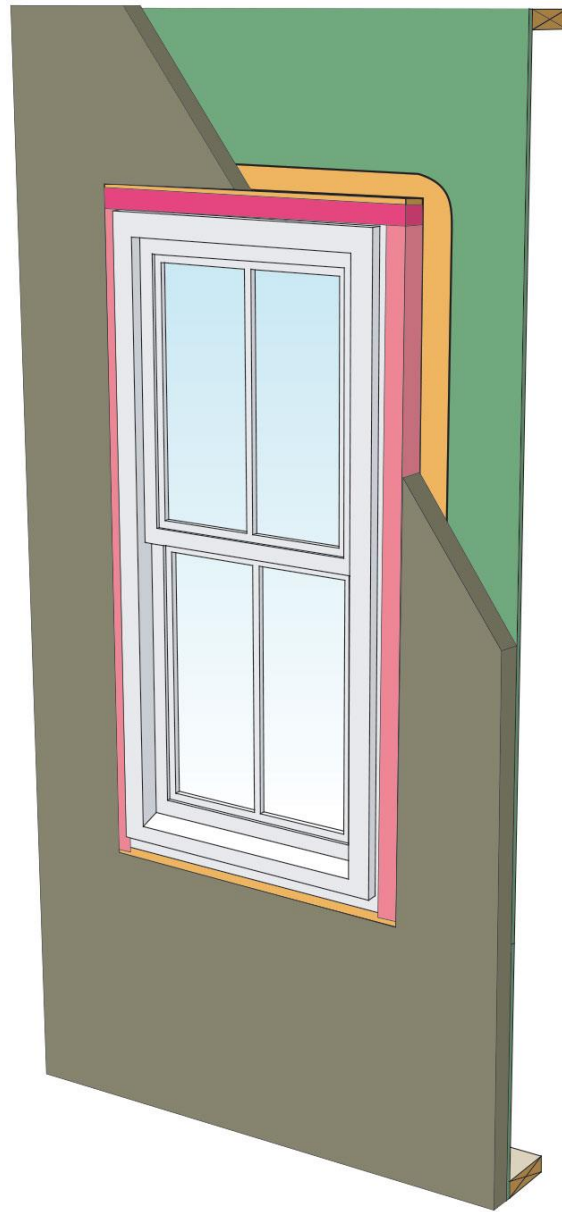


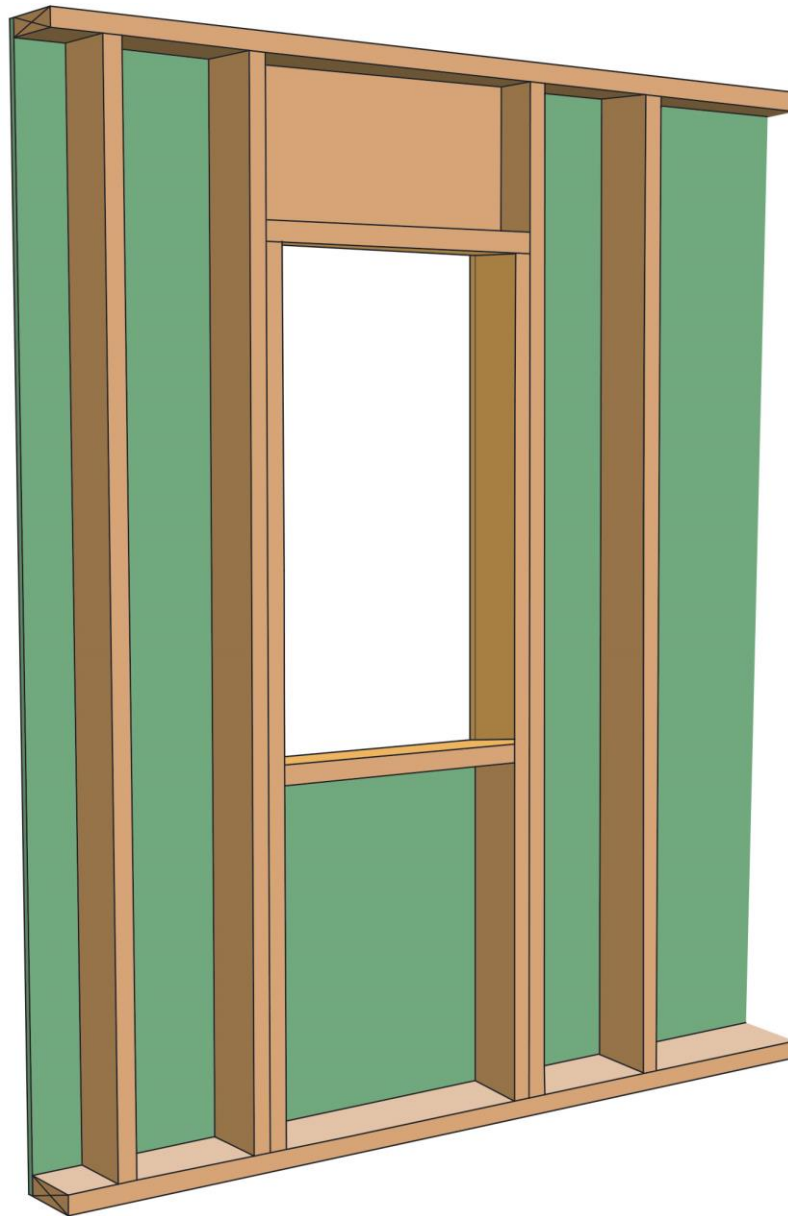






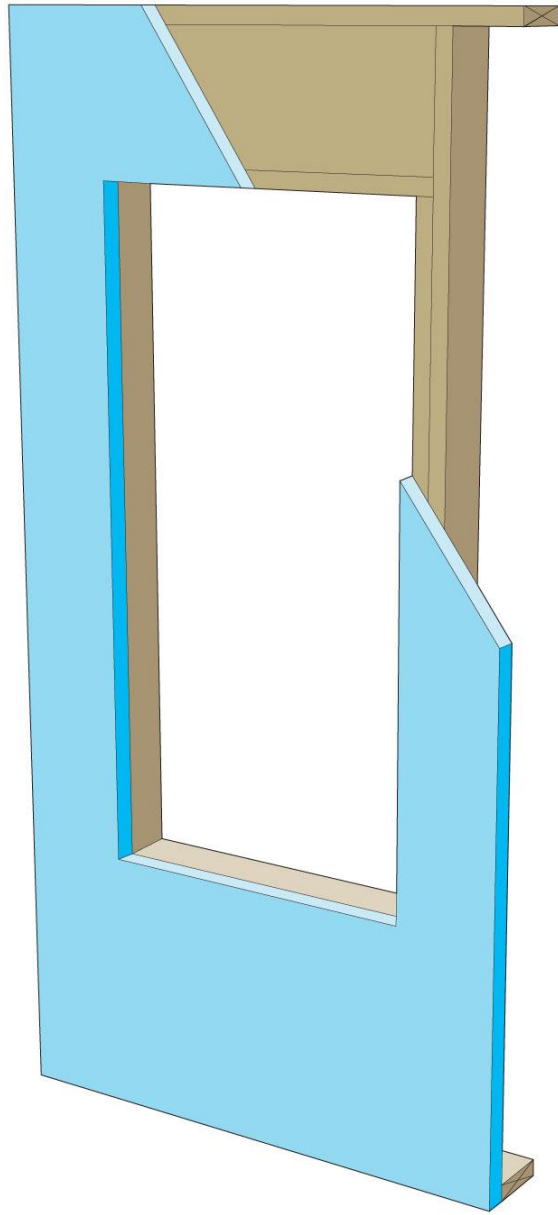


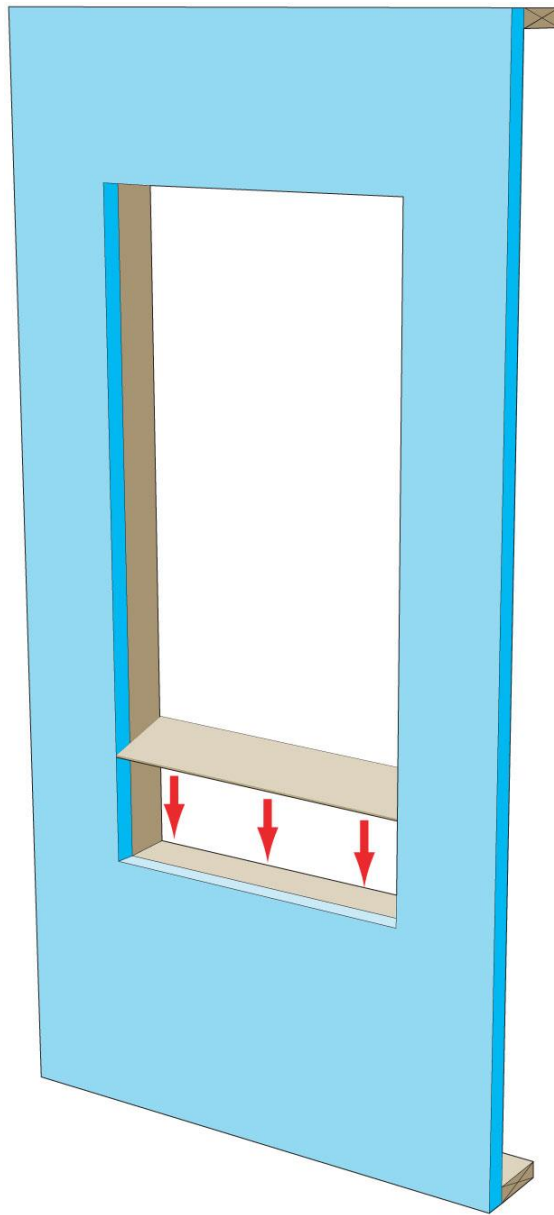


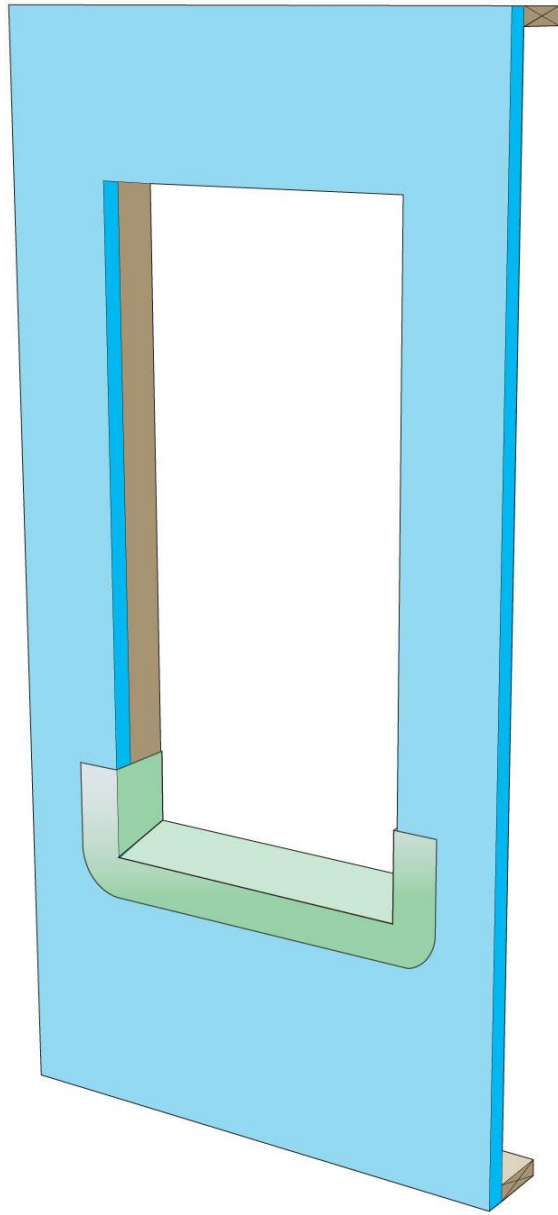


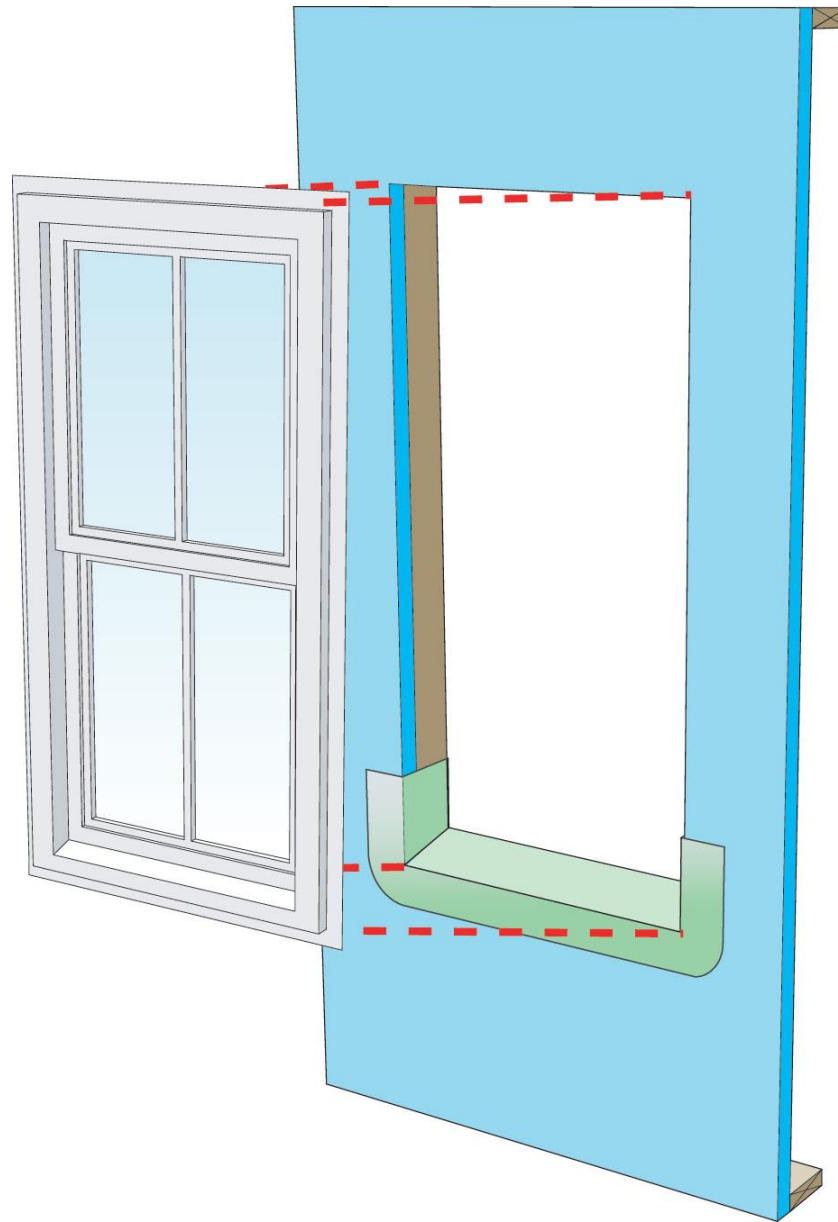


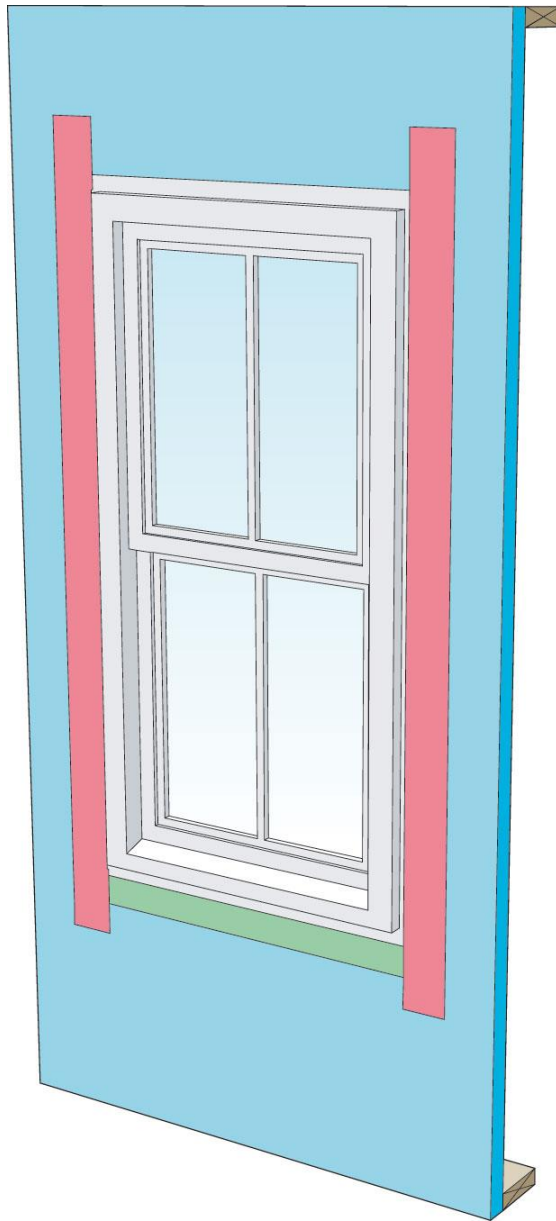


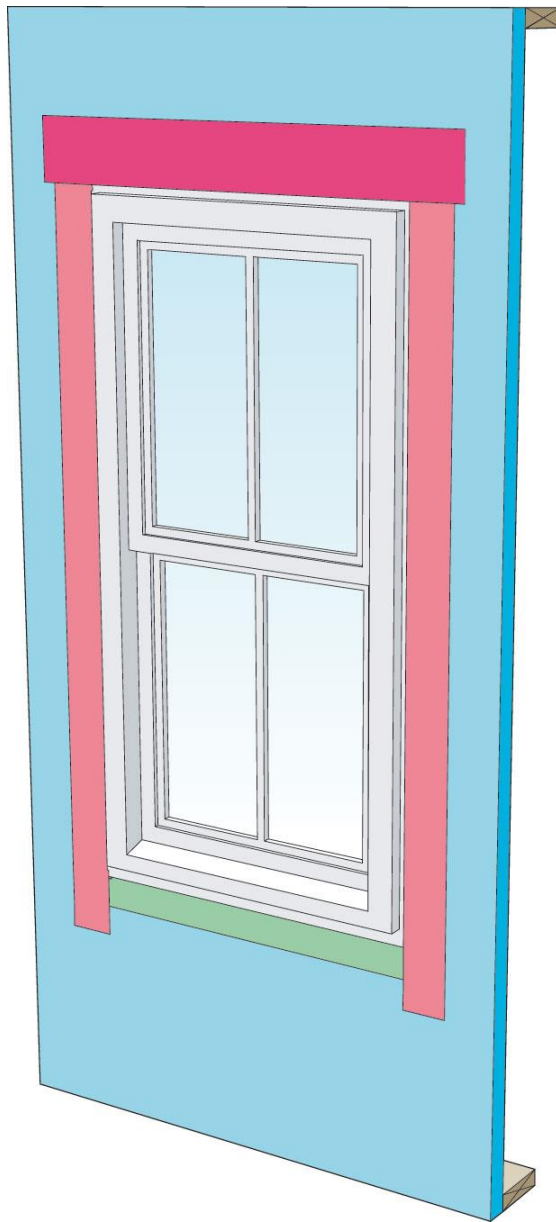


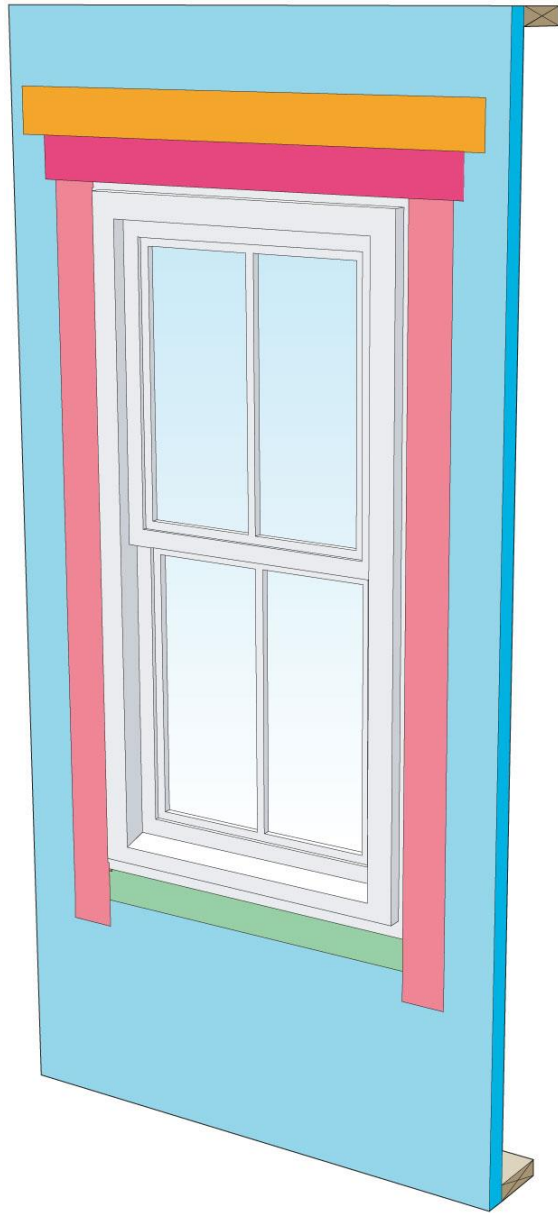


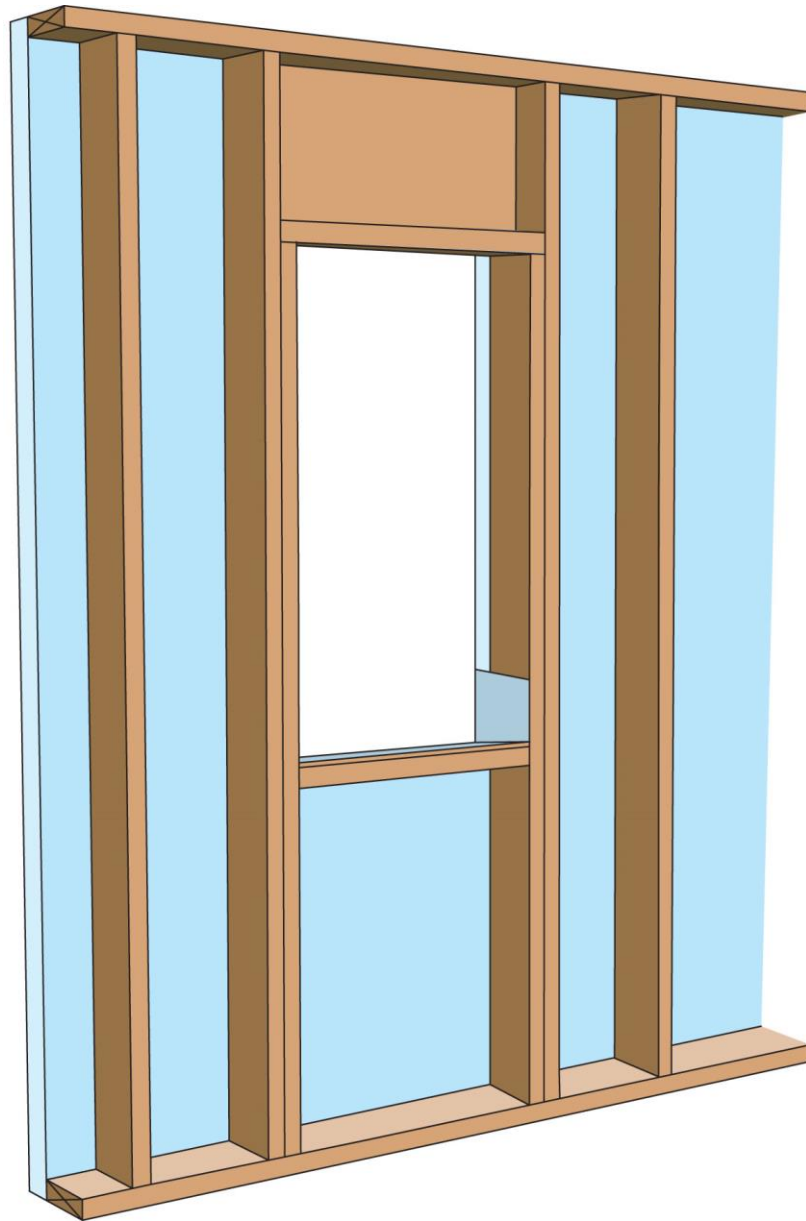


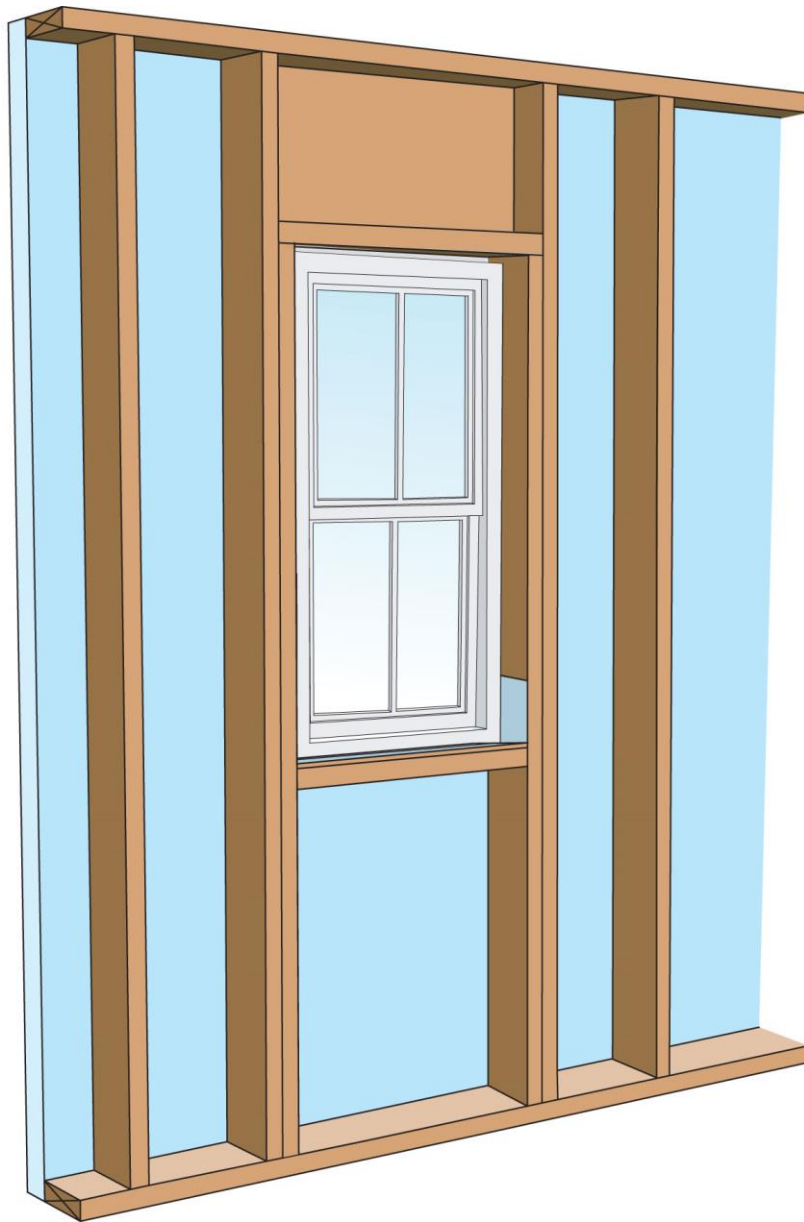


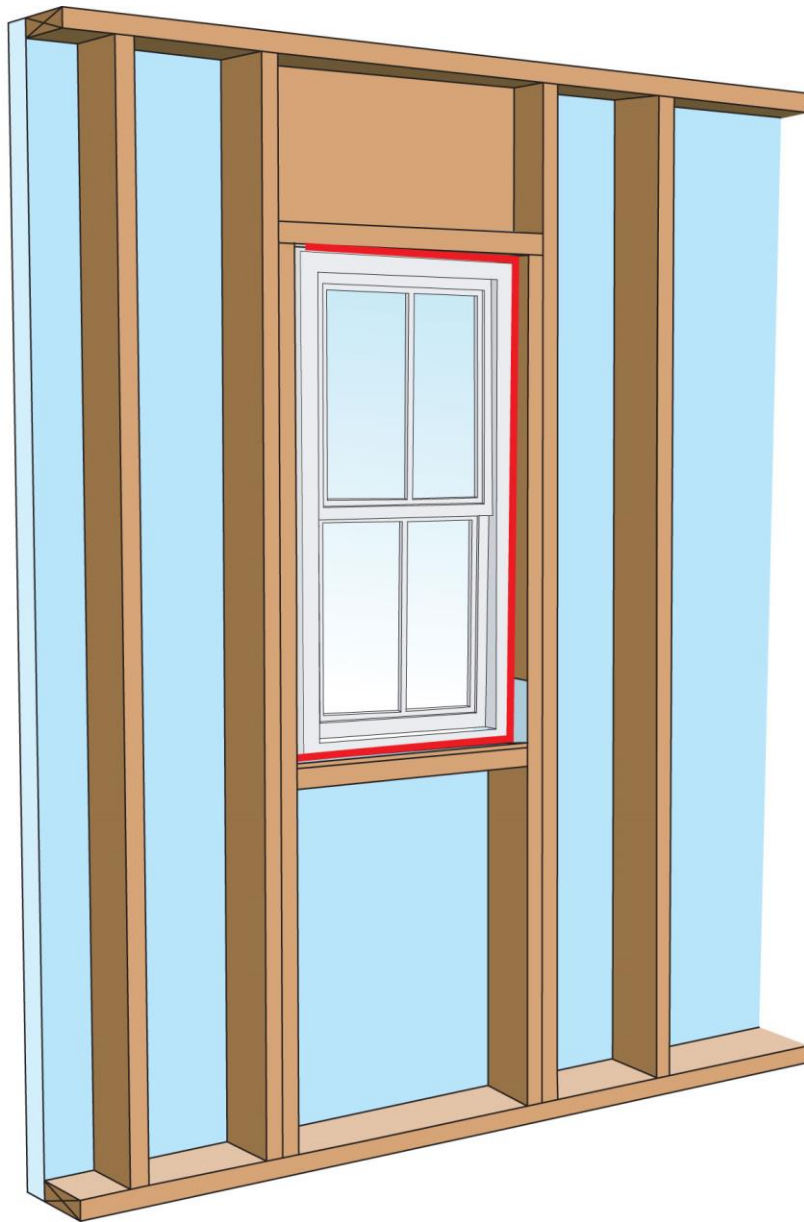




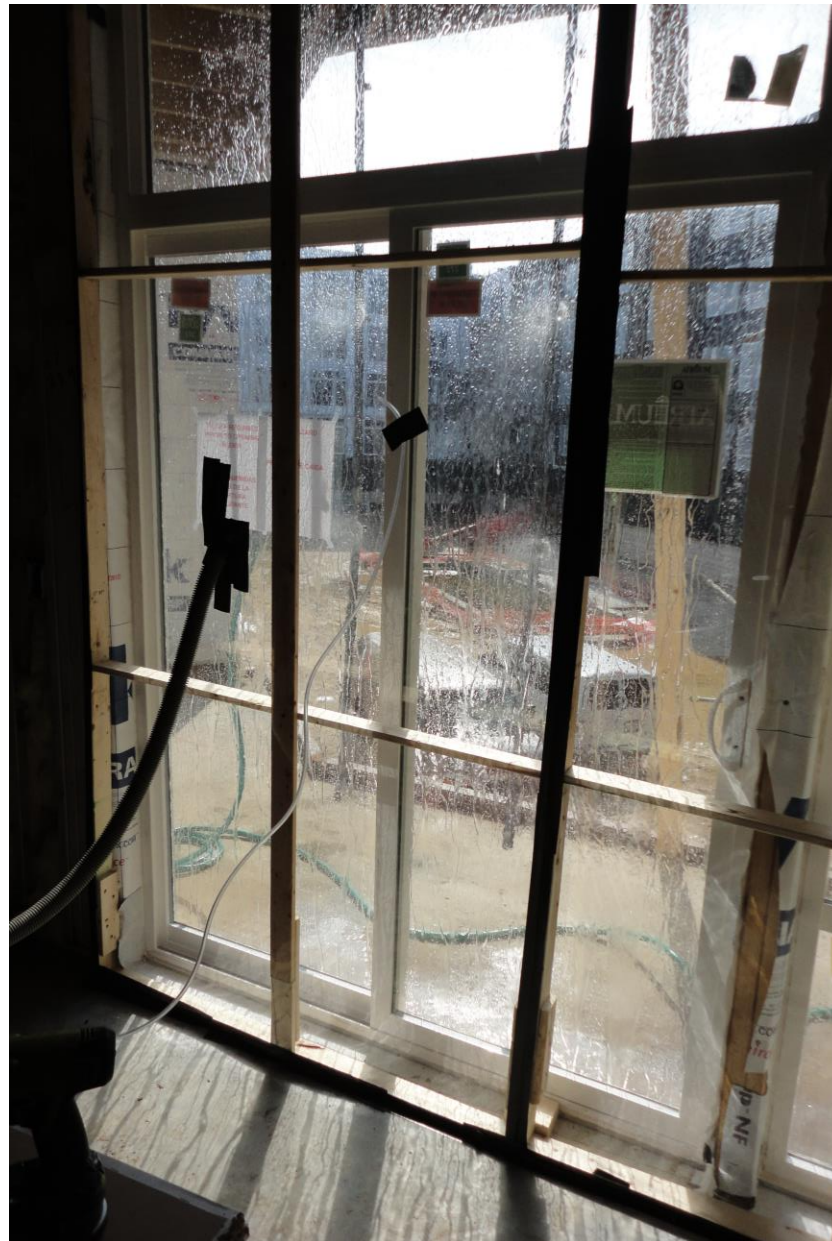


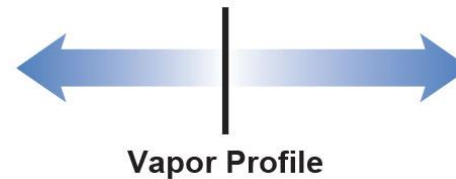
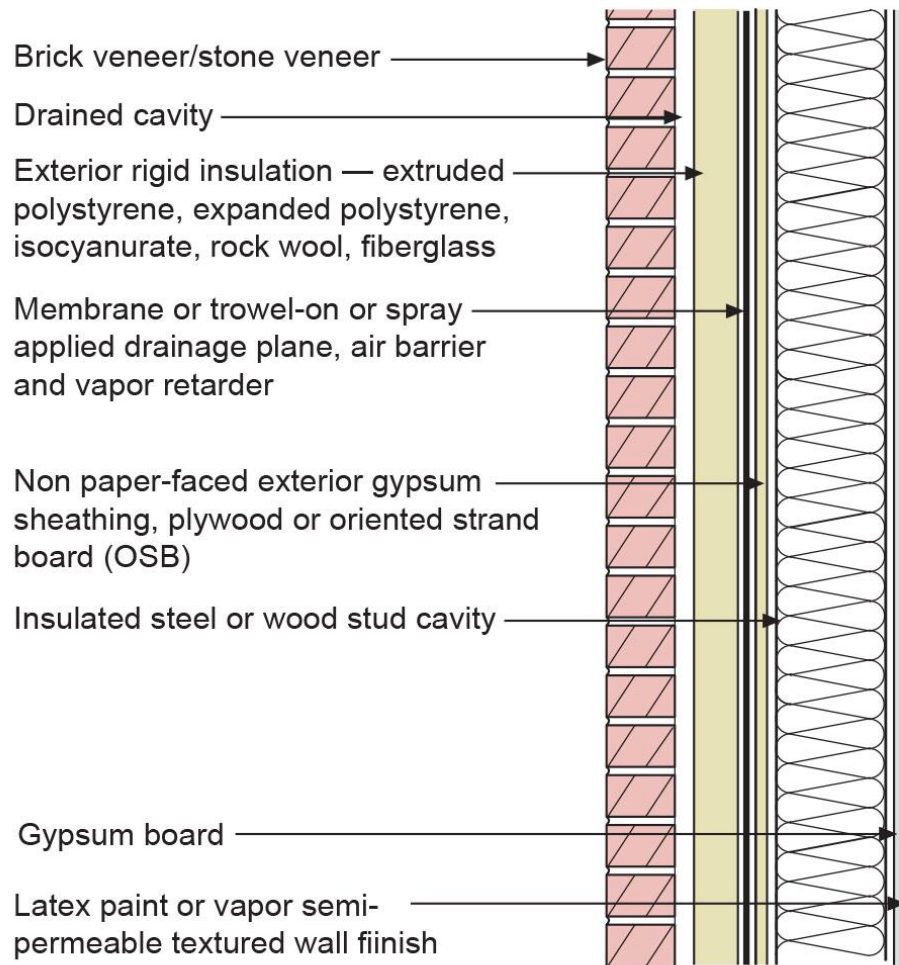












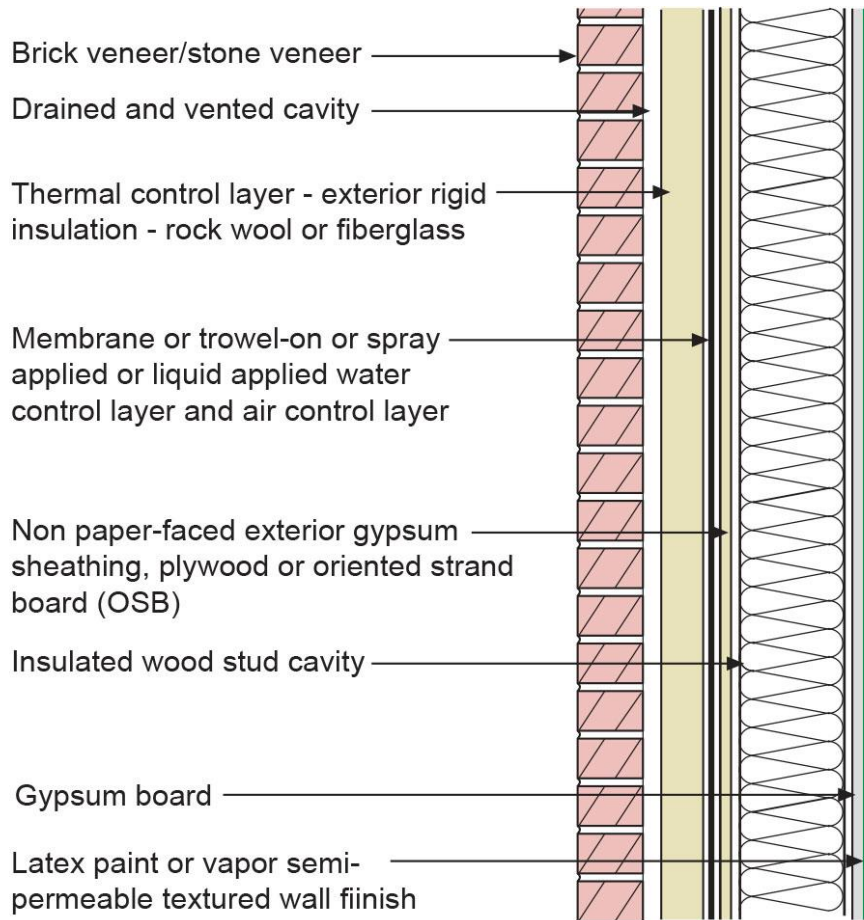
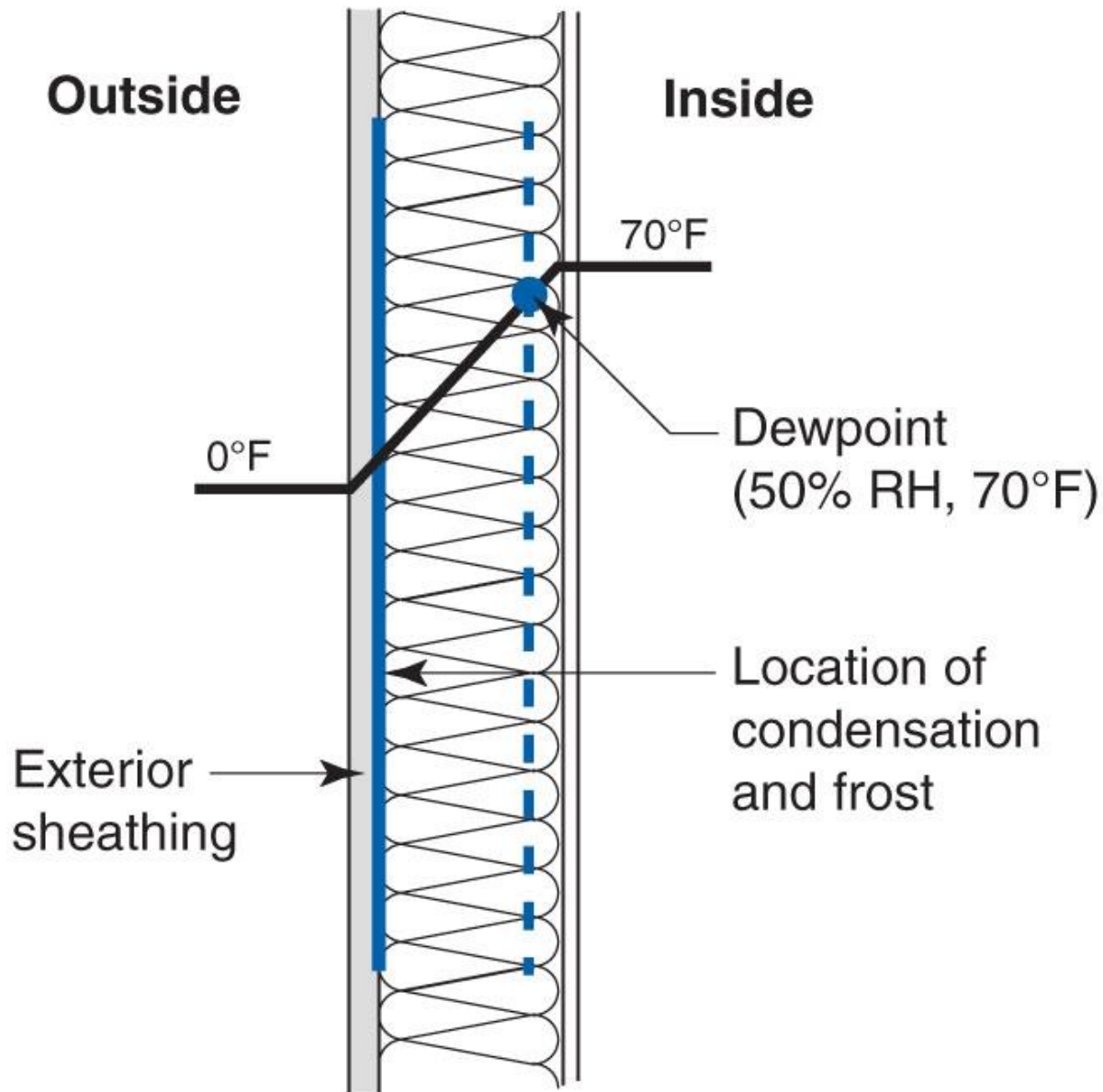


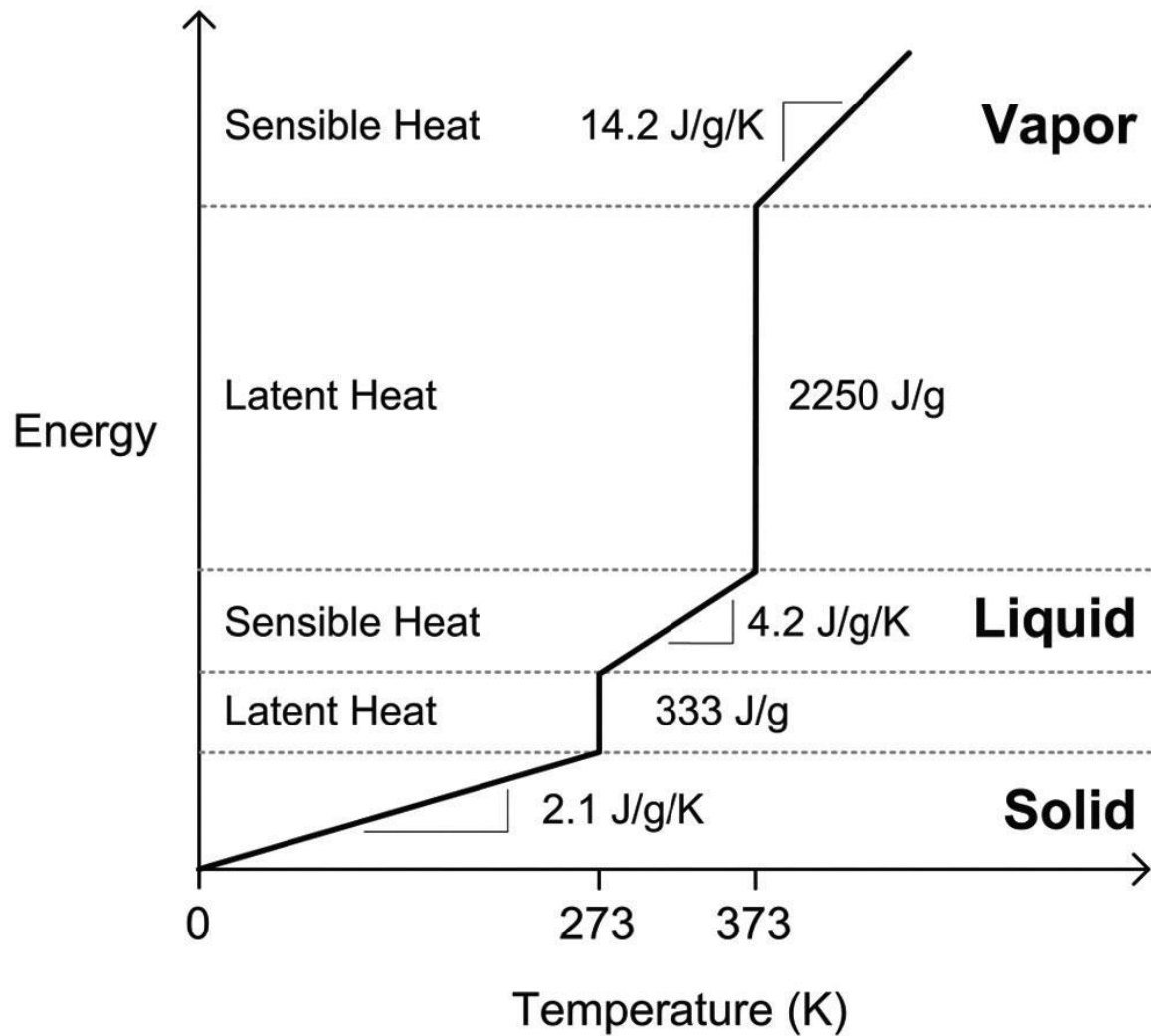
Figure 2c



Vapor Profile





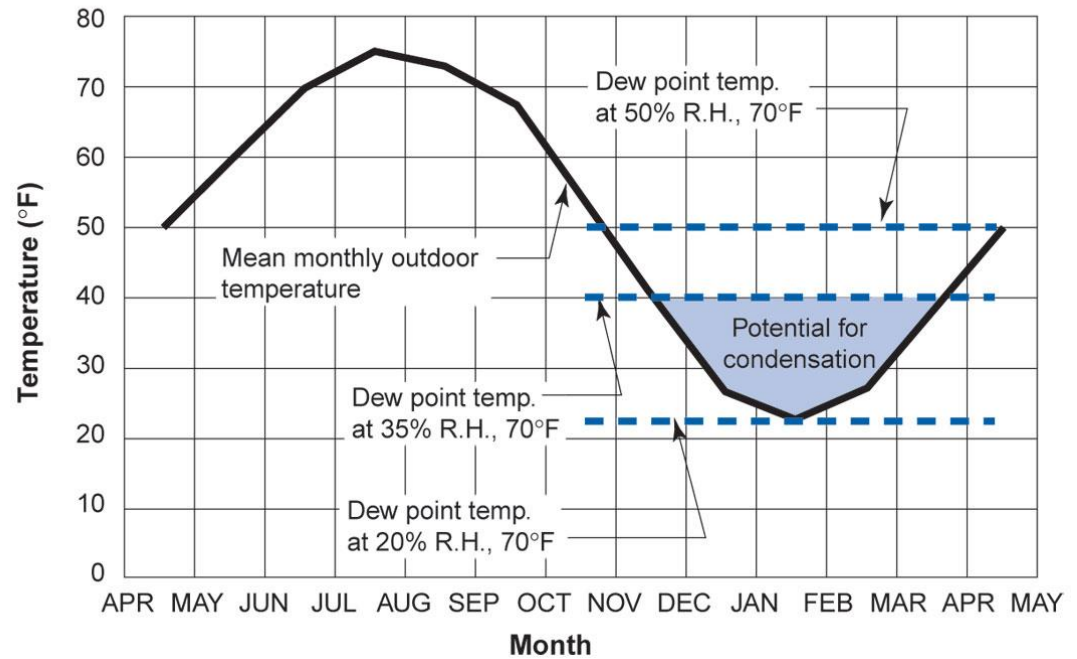
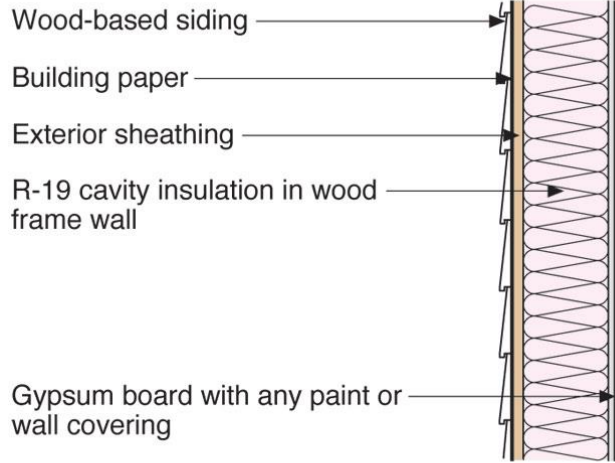


Simple linearized energy-temperature relation for water

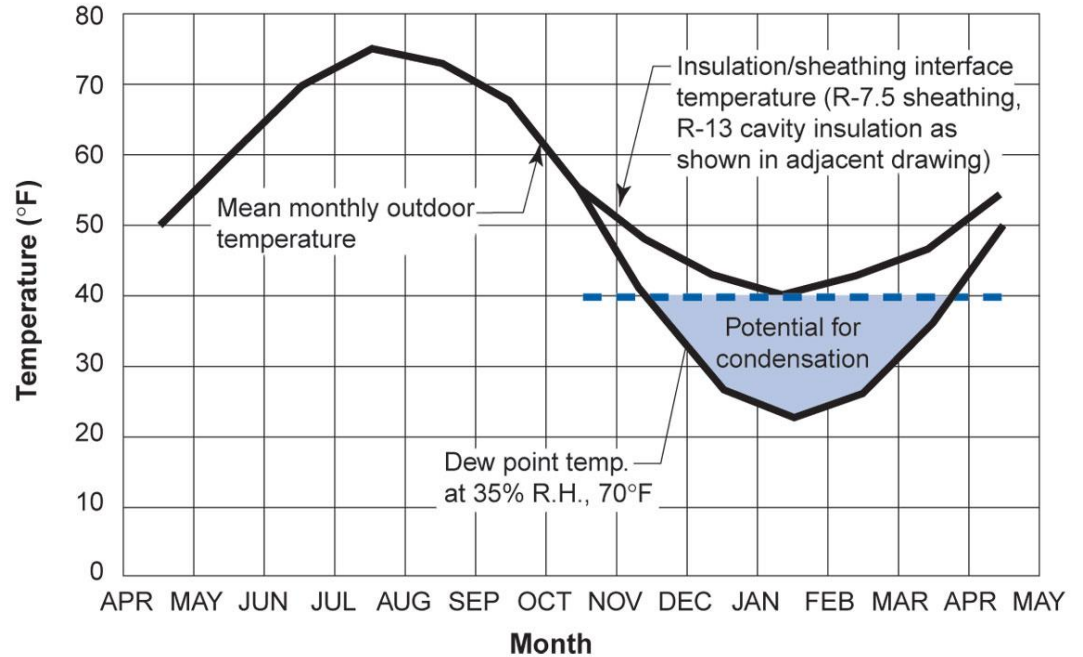
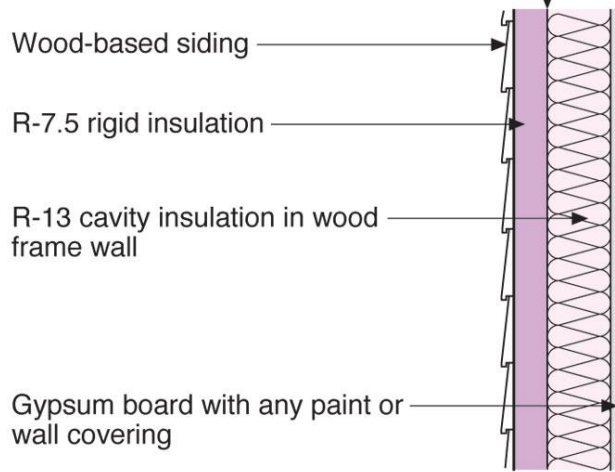
From Straube & Burnett, 2005



The inside face of the exterior sheathing is the condensing surface of interest



The inside face of the insulating sheathing is the condensing surface of interest



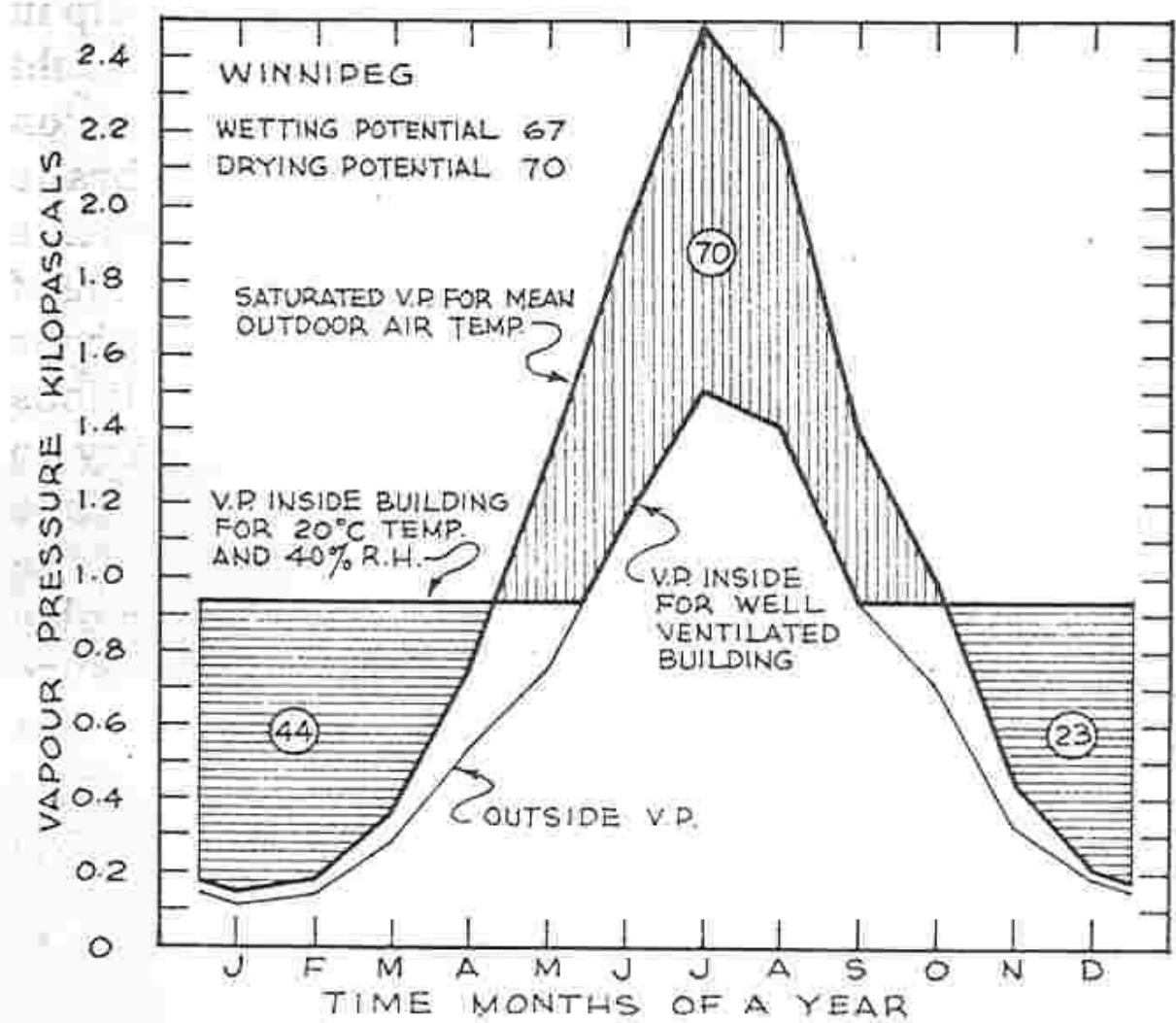
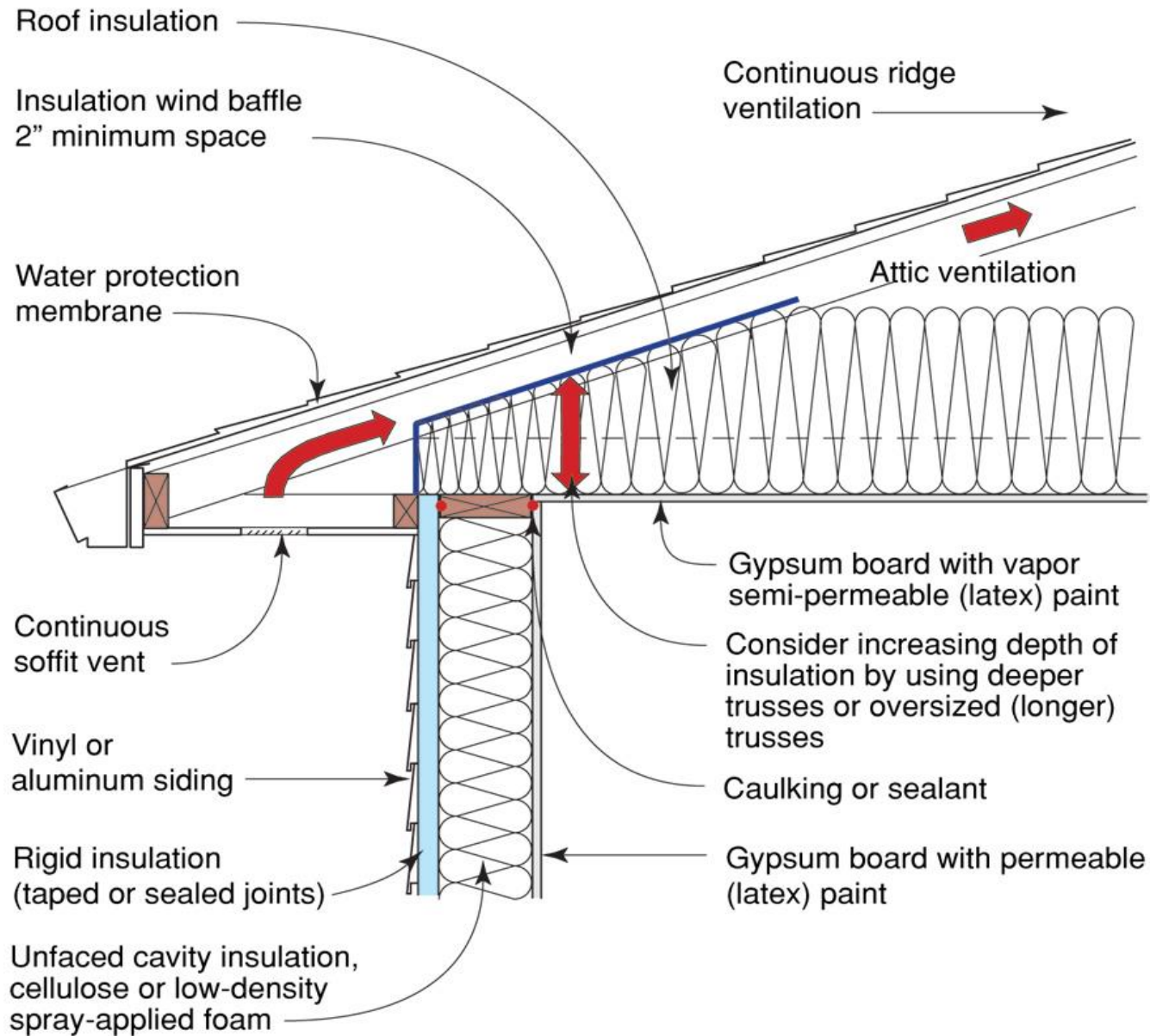
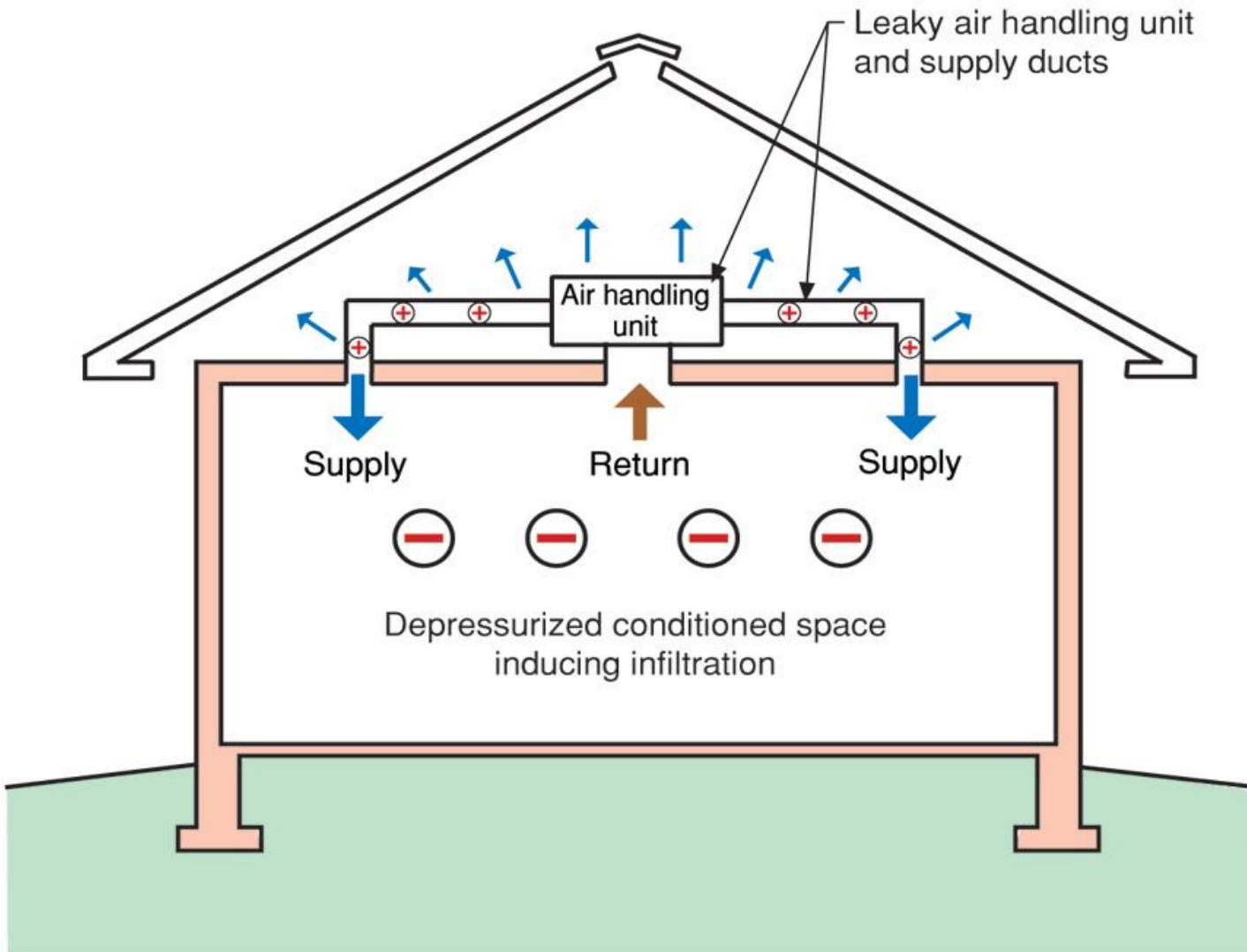


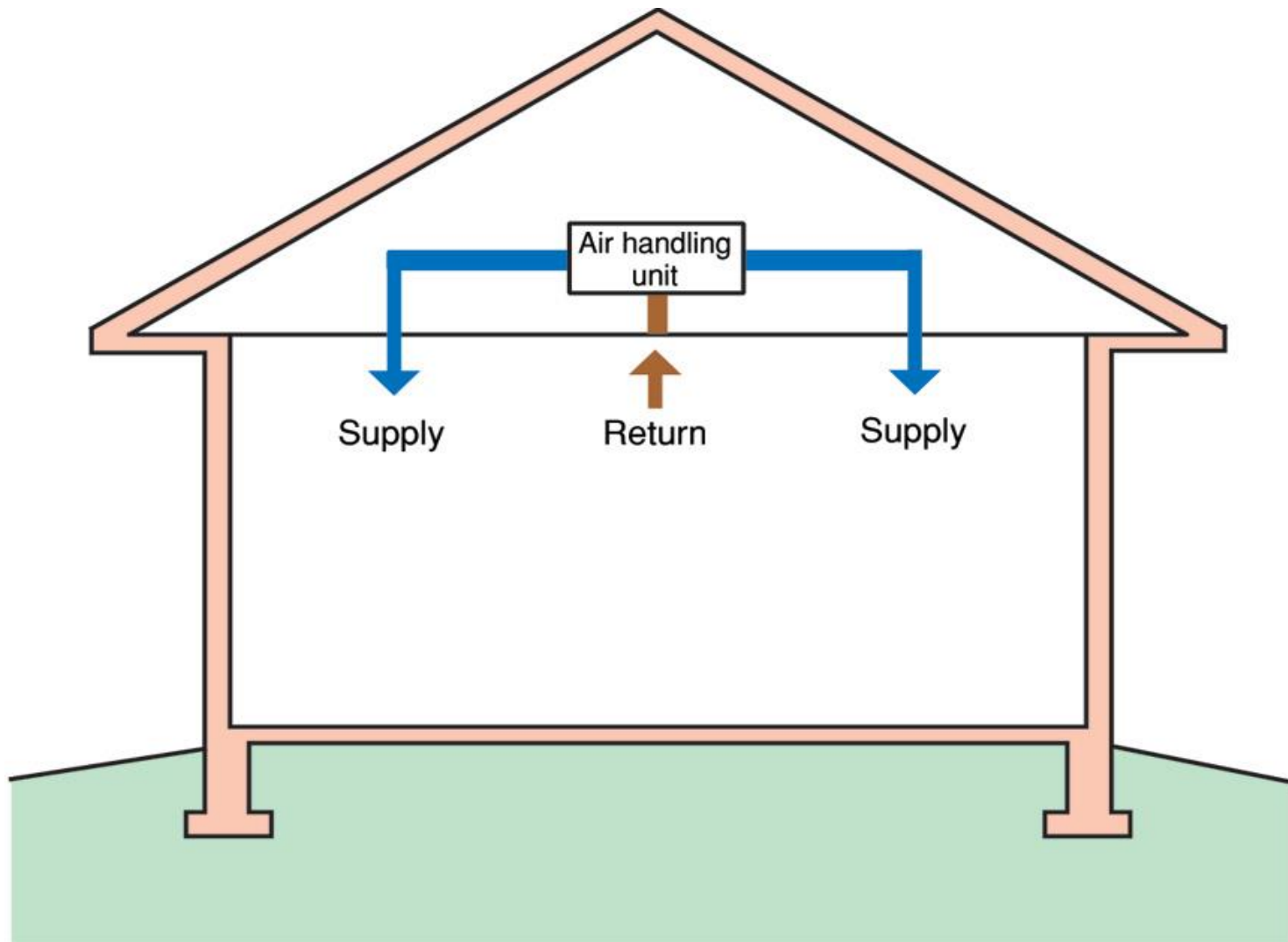
Figure 8-7. Outside vapour pressure, saturated vapour pressure and inside vapour pressure for Winnipeg.



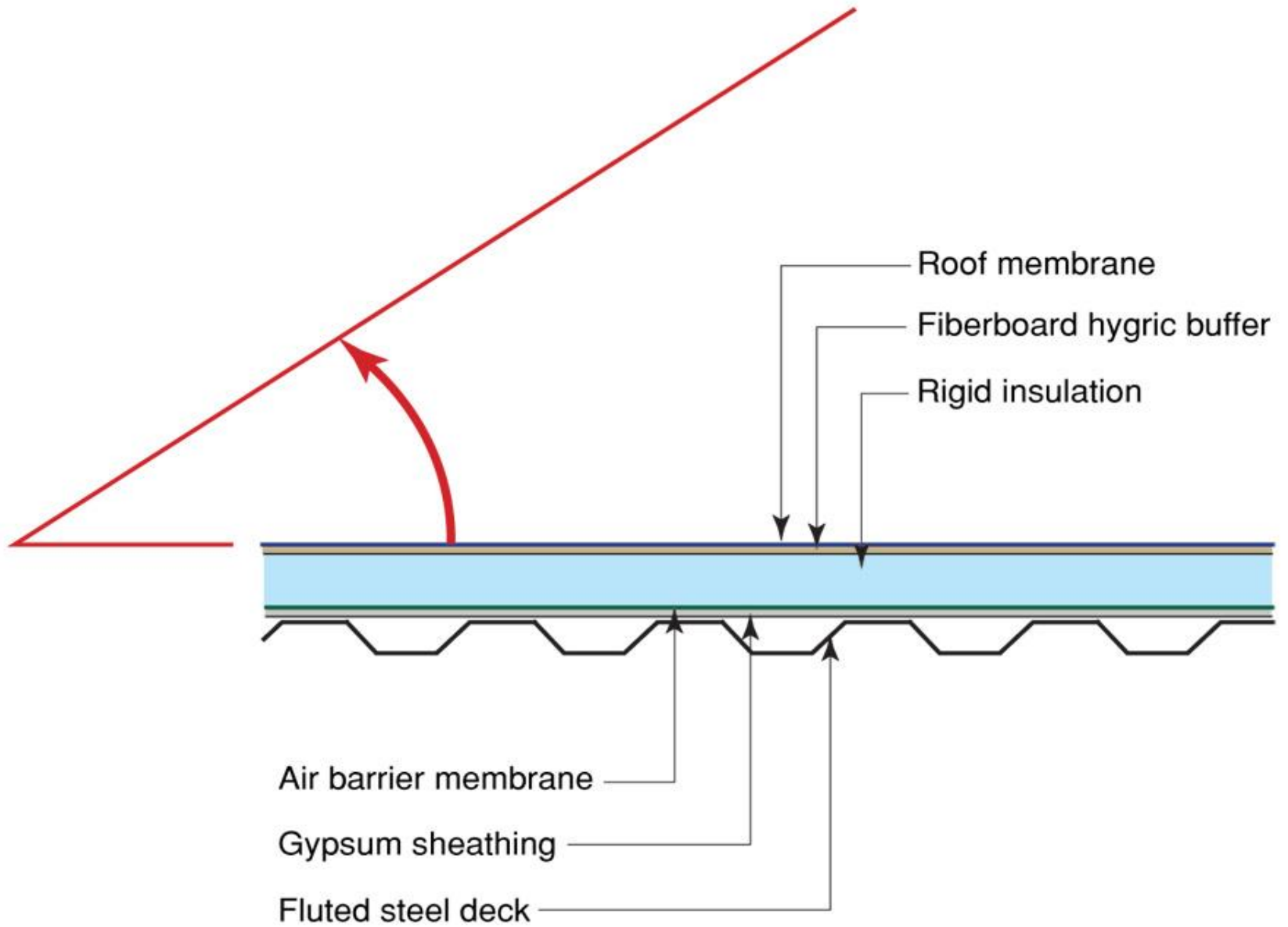


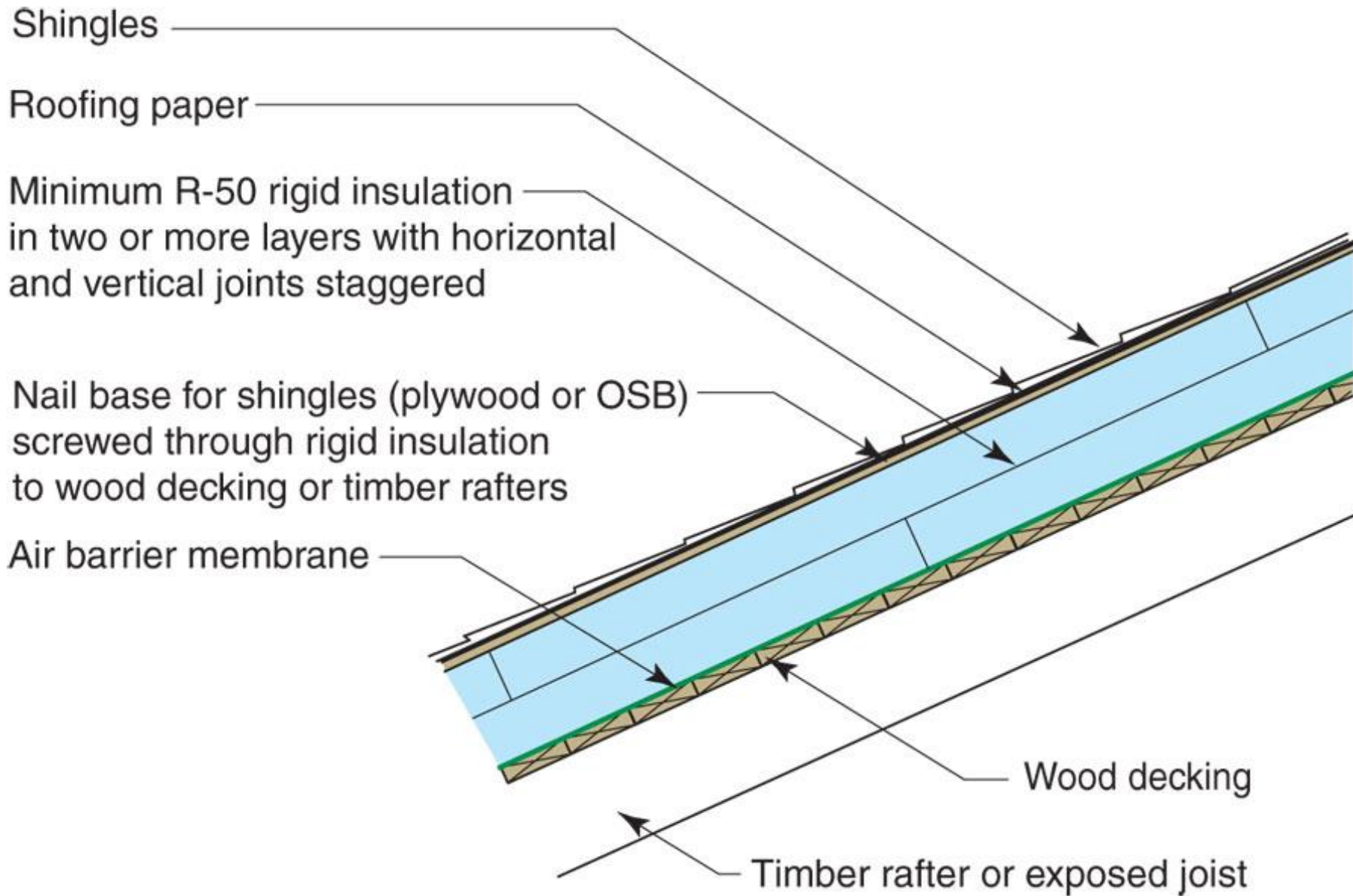


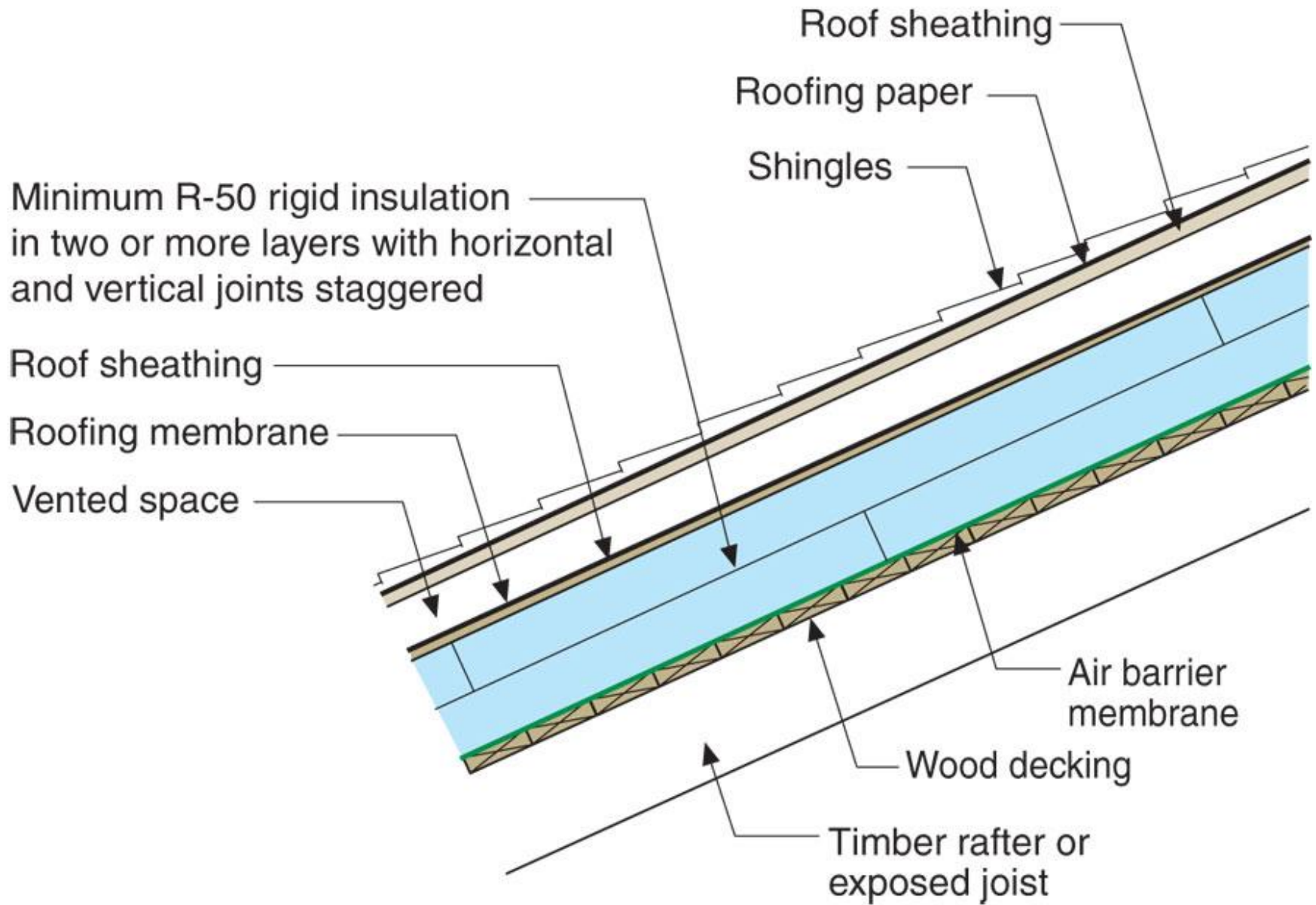
Note: Colored shading depicts the building's thermal barrier and pressure boundary. The thermal barrier and pressure boundary enclose the conditioned space.

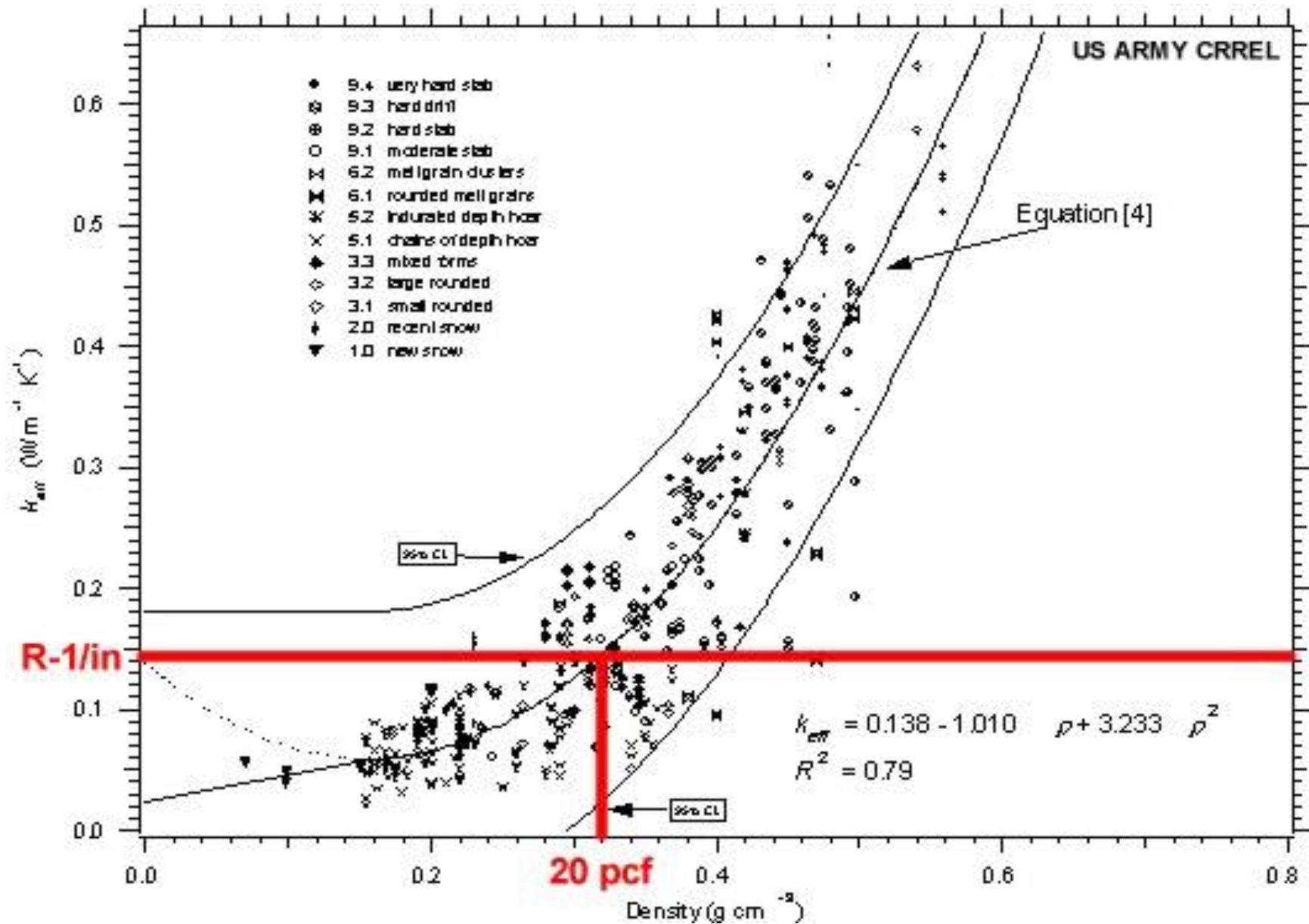


Note: Colored shading depicts the building's thermal barrier and pressure boundary. The thermal barrier and pressure boundary enclose the conditioned space.

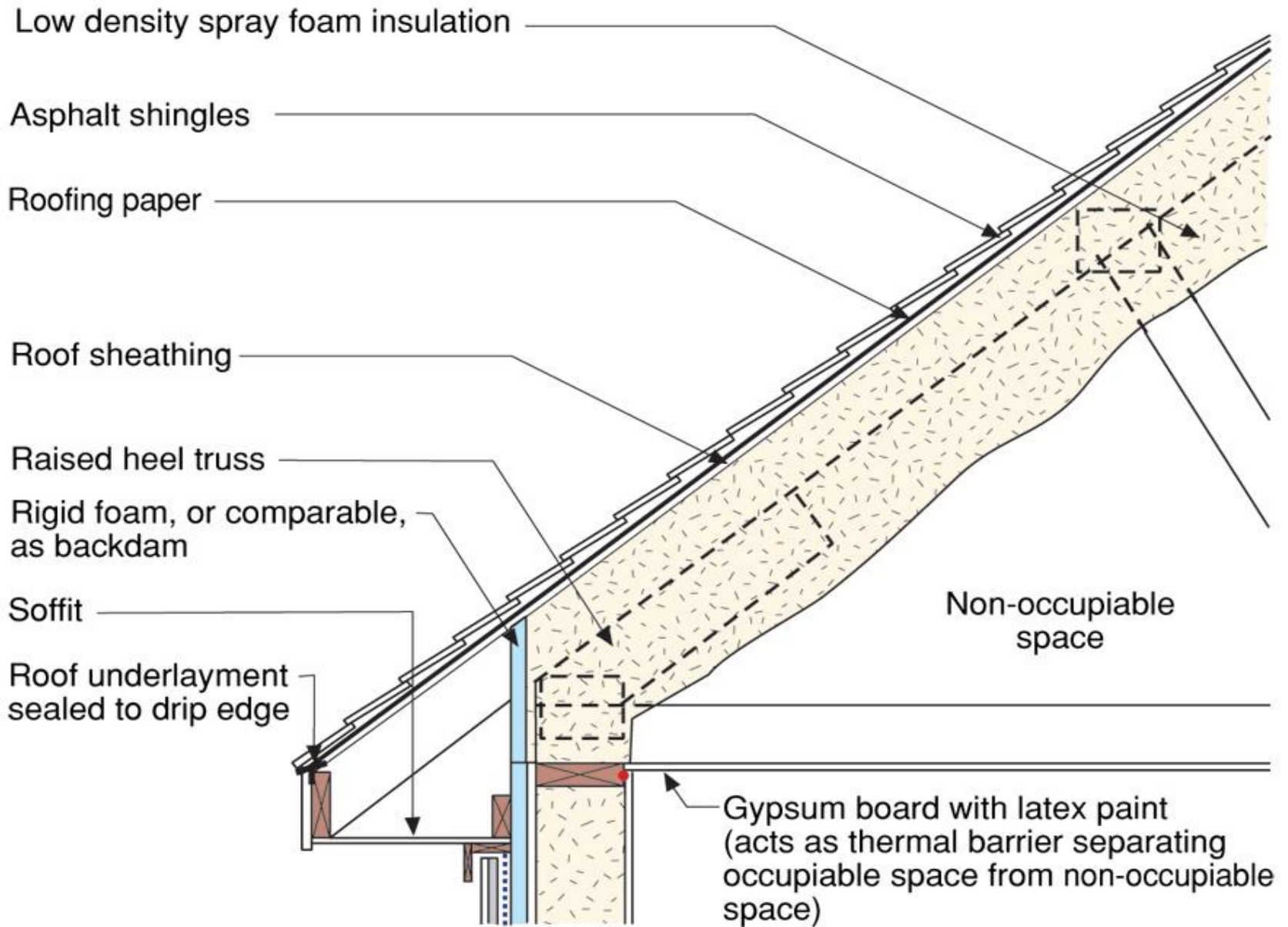










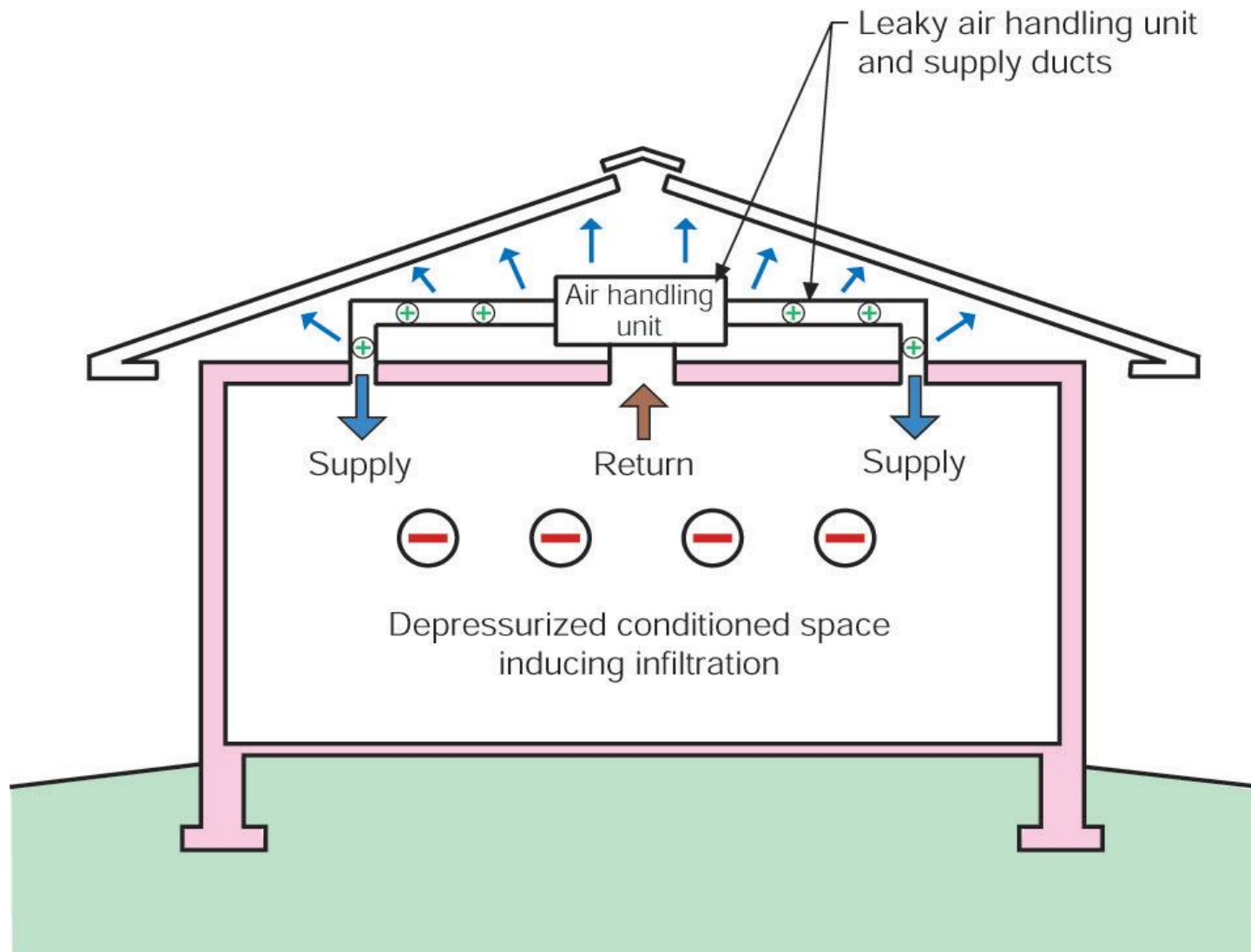




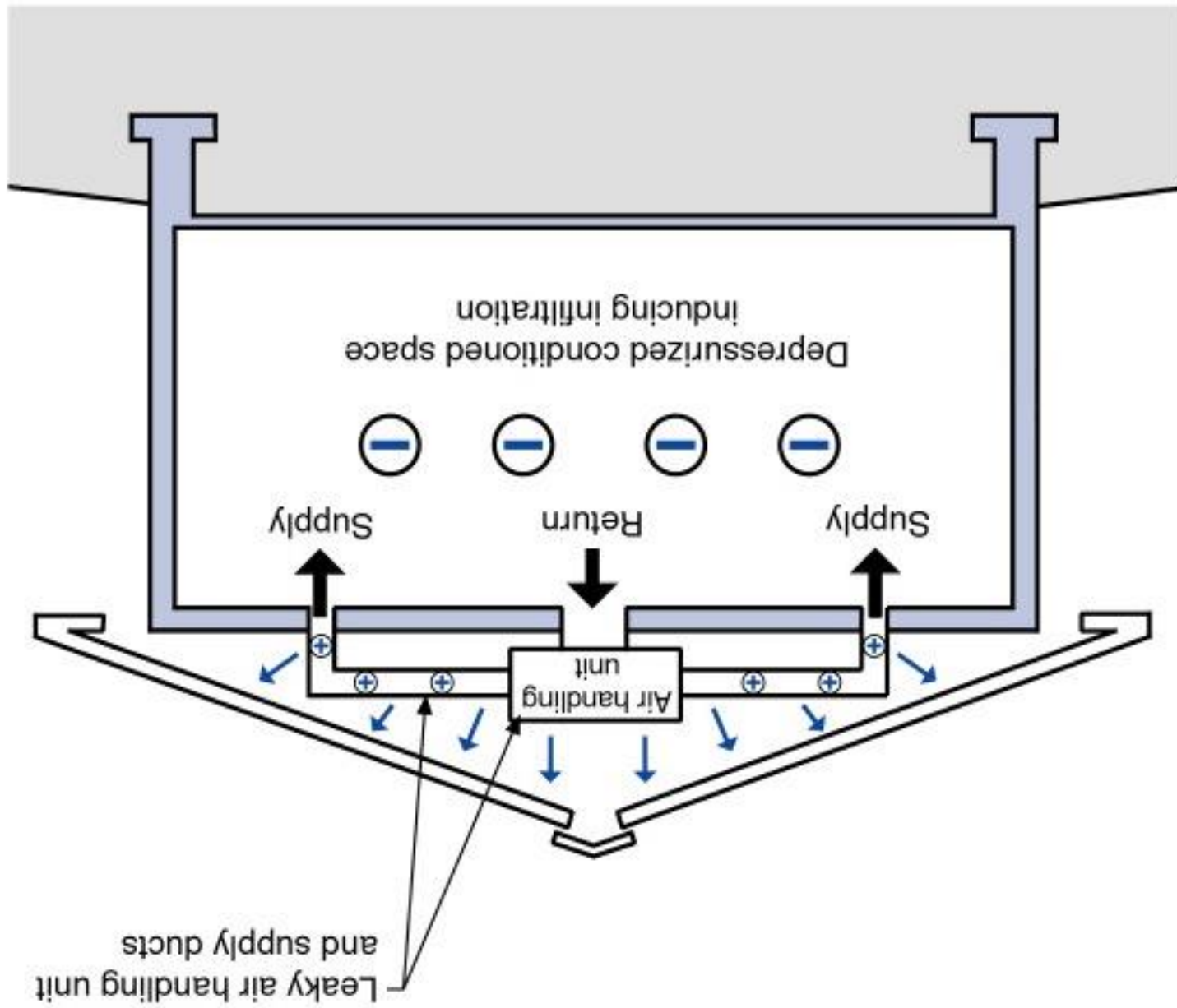


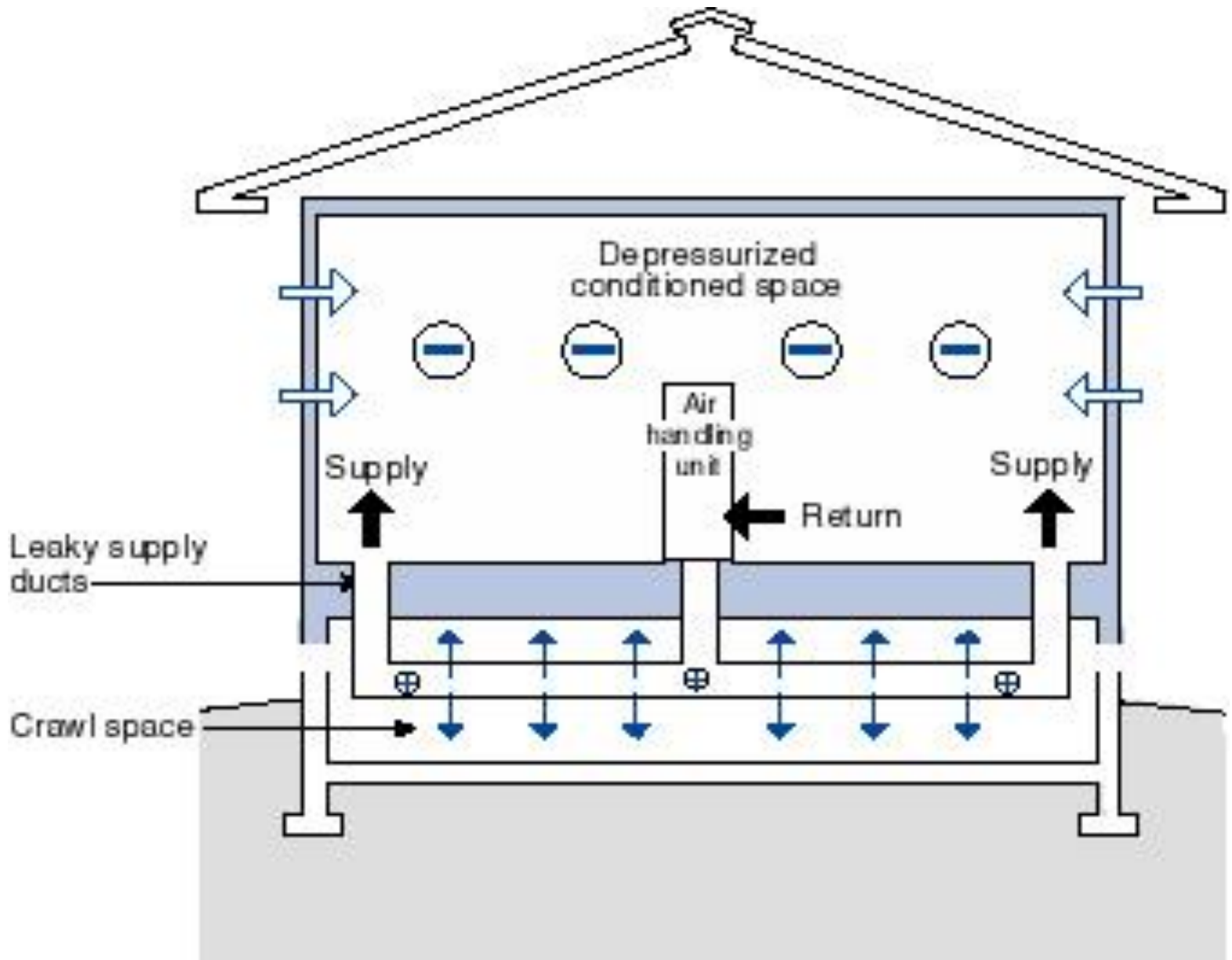






Note: Colored shading depicts the building's thermal barrier and pressure boundary. The thermal barrier and pressure boundary enclose the conditioned space.











**Current Approach
(BAD)**

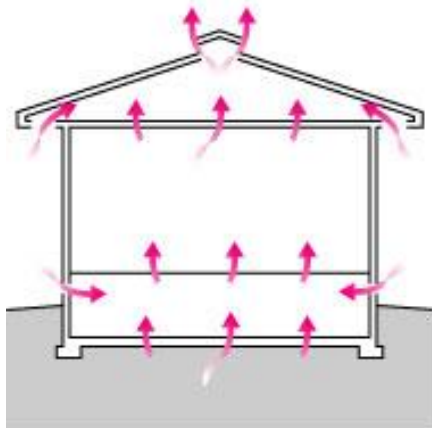


Figure A

- leaky subfloor
- poor ground cover
- stack effect vents crawl space through house
- contaminants in crawl space migrate into house

**Better Approach
(GOOD)**

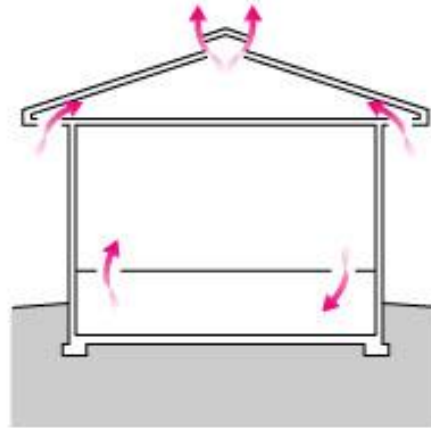


Figure B

- excellent ground cover
 - conditioned crawl space connected to house with transfer grilles and supplied with air from heating supply duct
- (This is really a mini-basement and is already allowed by many code departments — i.e. Ft. Collins)

**Even Better Approach
(GREAT)**

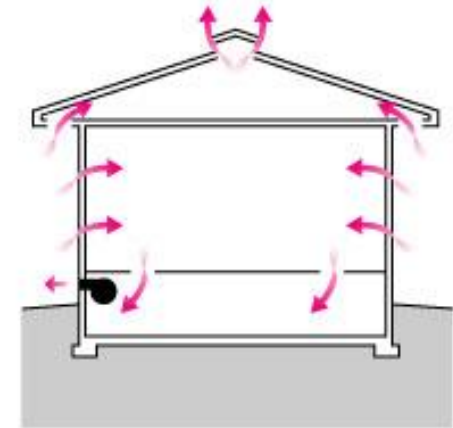


Figure C

- excellent ground cover
 - conditioned crawl space via transfer air from occupied space
 - continuously operating exhaust fan in crawl space vents house through crawl space
- (This is not considered by the code but should be)

