

Joseph Lstiburek, Ph.D., P.Eng, ASHRAE Fellow

Building Science

Adventures In Building Science

presented by www.buildingscience.com

Build Tight - Ventilate Right

Build Tight - Ventilate Right

How Tight?

What's Right?

Air Barrier Metrics

Material	0.02 l/(s-m ²) @ 75 Pa
Assembly	0.20 l/(s-m ²) @ 75 Pa
Enclosure	2.00 l/(s-m ²) @ 75 Pa
	0.35 cfm/ft ² @ 50 Pa
	0.25 cfm/ft ² @ 50 Pa
	0.15 cfm/ft ² @ 50 Pa

Getting rid of big holes	3 ach@50
Getting rid of smaller holes	1.5 ach@50
Getting German	0.6 ach@50

Best

As Tight as Possible - with -

Balanced Ventilation

Energy Recovery

Distribution and Mixing

Source Control - Spot exhaust ventilation

Filtration

Material selection

Dilution Is Not The Solution To Indoor Pollution

Source Control

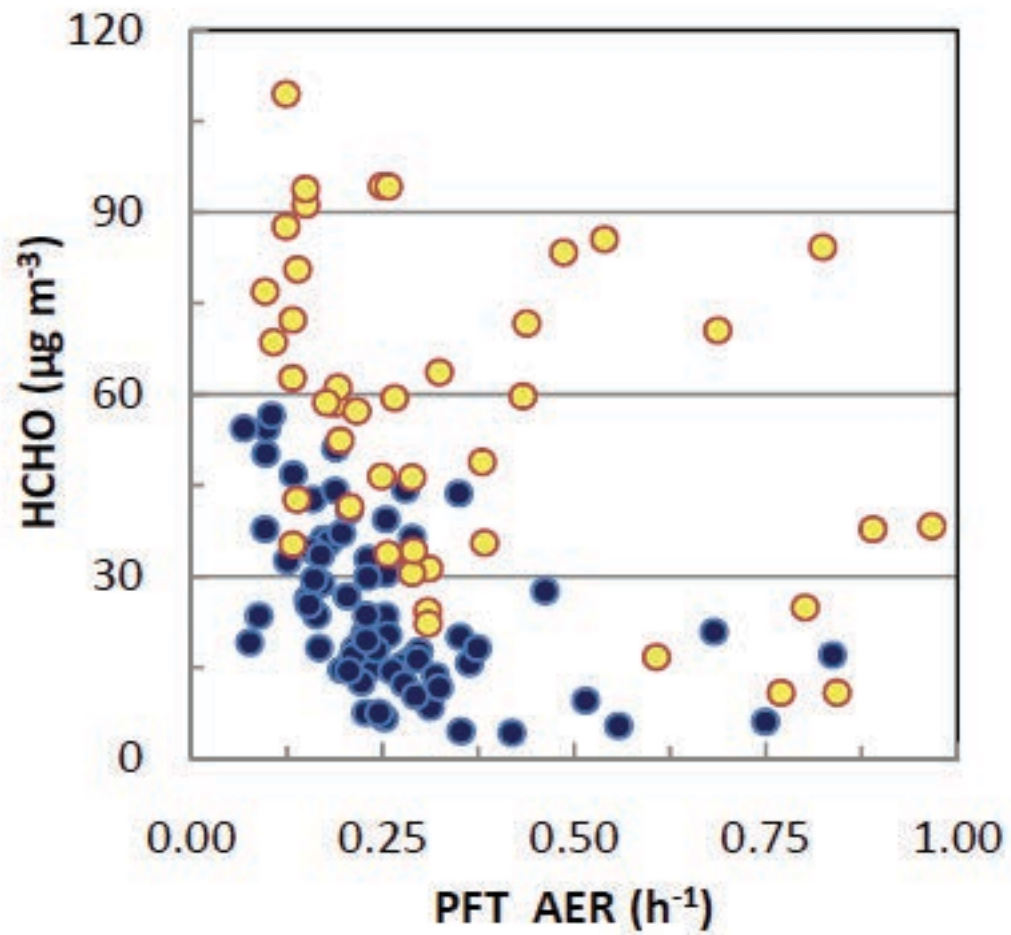

Aubin, D., Won, D.Y., Schliebinger, H., 2010

Formaldehyde sample concentration versus PFT measured outside air exchange rate over the test day

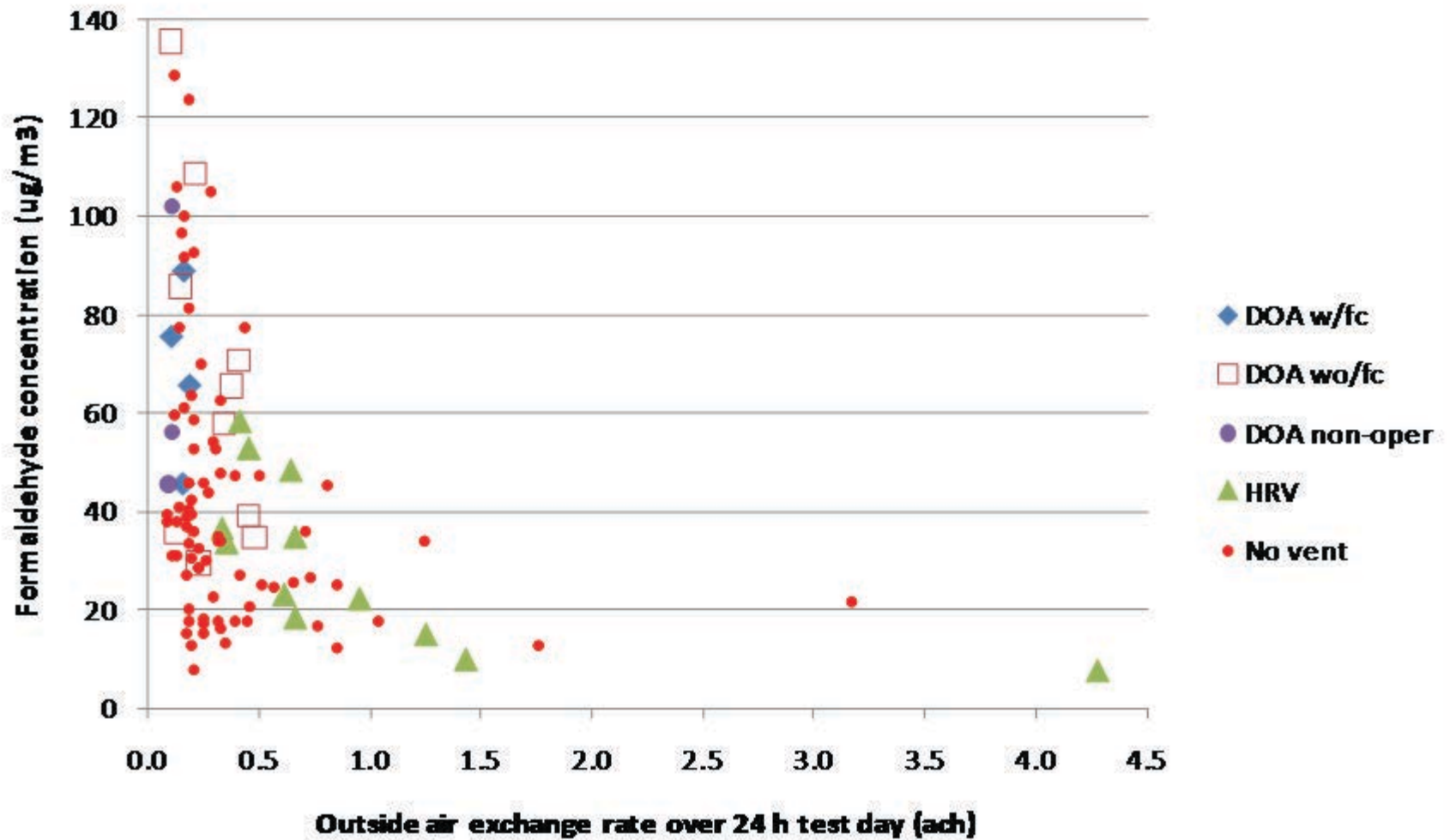

Dilution For People

Source Control For The Building

Ventilation Rates Are Based on Odor Control
Health Science Basis for Ventilation Rates is
Extremely Limited

Ventilation Rates Are Based on Odor Control
Health Science Basis for Ventilation Rates is
Extremely Limited
Almost Nothing Cited Applies to Housing

Ventilation Rates Are Based on Odor Control
Health Science Basis for Ventilation Rates is
Extremely Limited

Almost Nothing Cited Applies to Housing

The Applicable Studies Focus on Dampness

ASHRAE Standard 62.2 calls for 7.5 cfm per person plus 0.03 cfm per square foot of conditioned area

Occupancy is deemed to be the number of bedrooms plus one

ASHRAE Standard 62.2 calls for 7.5 cfm per person plus 0.03 cfm per square foot of conditioned area

Occupancy is deemed to be the number of bedrooms plus one

Outcome is often bad – part load humidity problems, dryness problems, energy problems

IRC 2015 calls for 7.5 cfm per person plus
0.01 cfm per square foot of conditioned
area

Occupancy is deemed to be the number of
bedrooms plus one

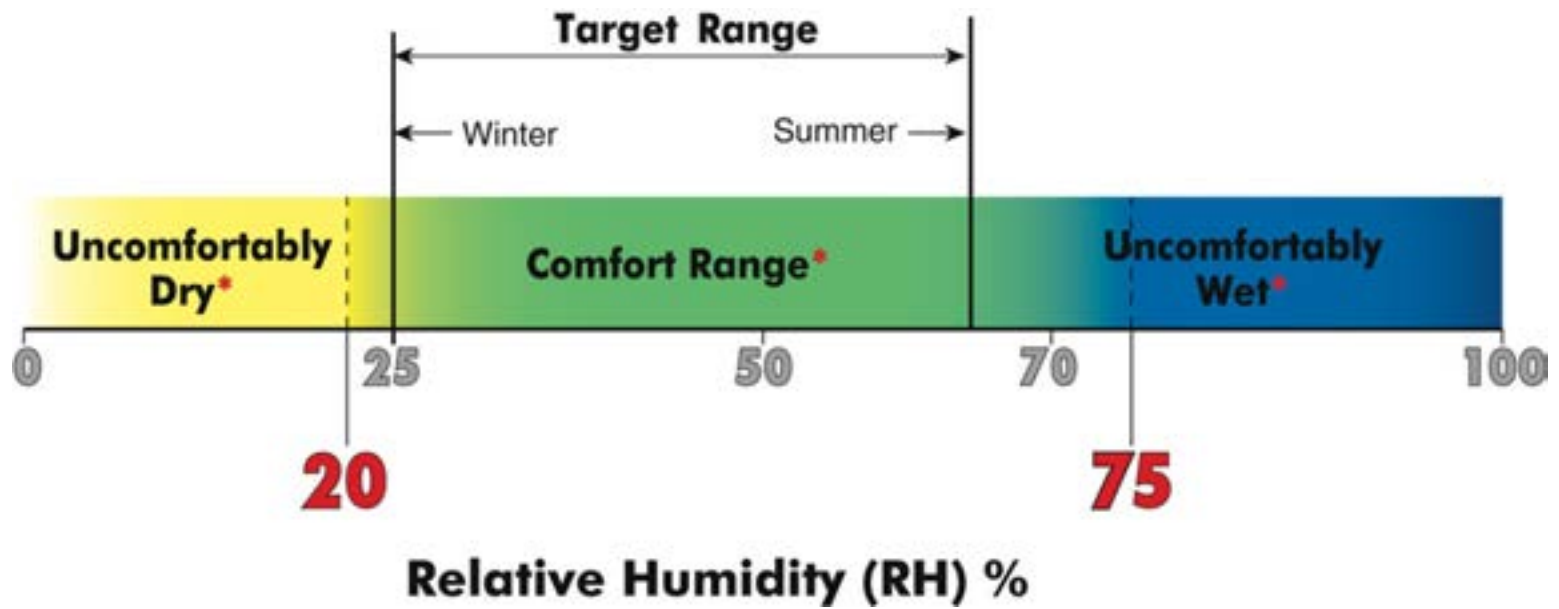

Recommended Range of Relative Humidity

Above 25 percent during winter

Below 70 percent during summer

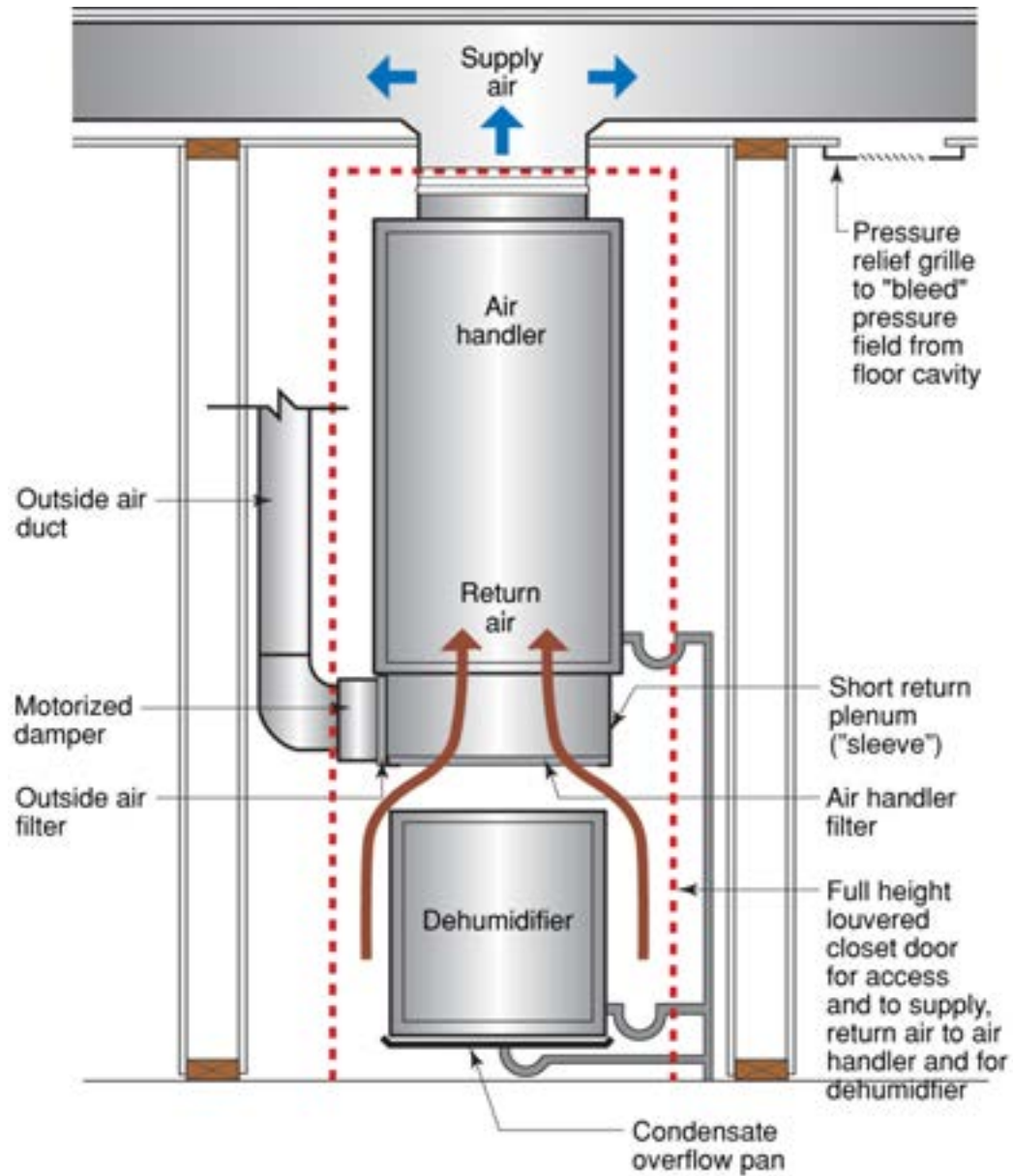



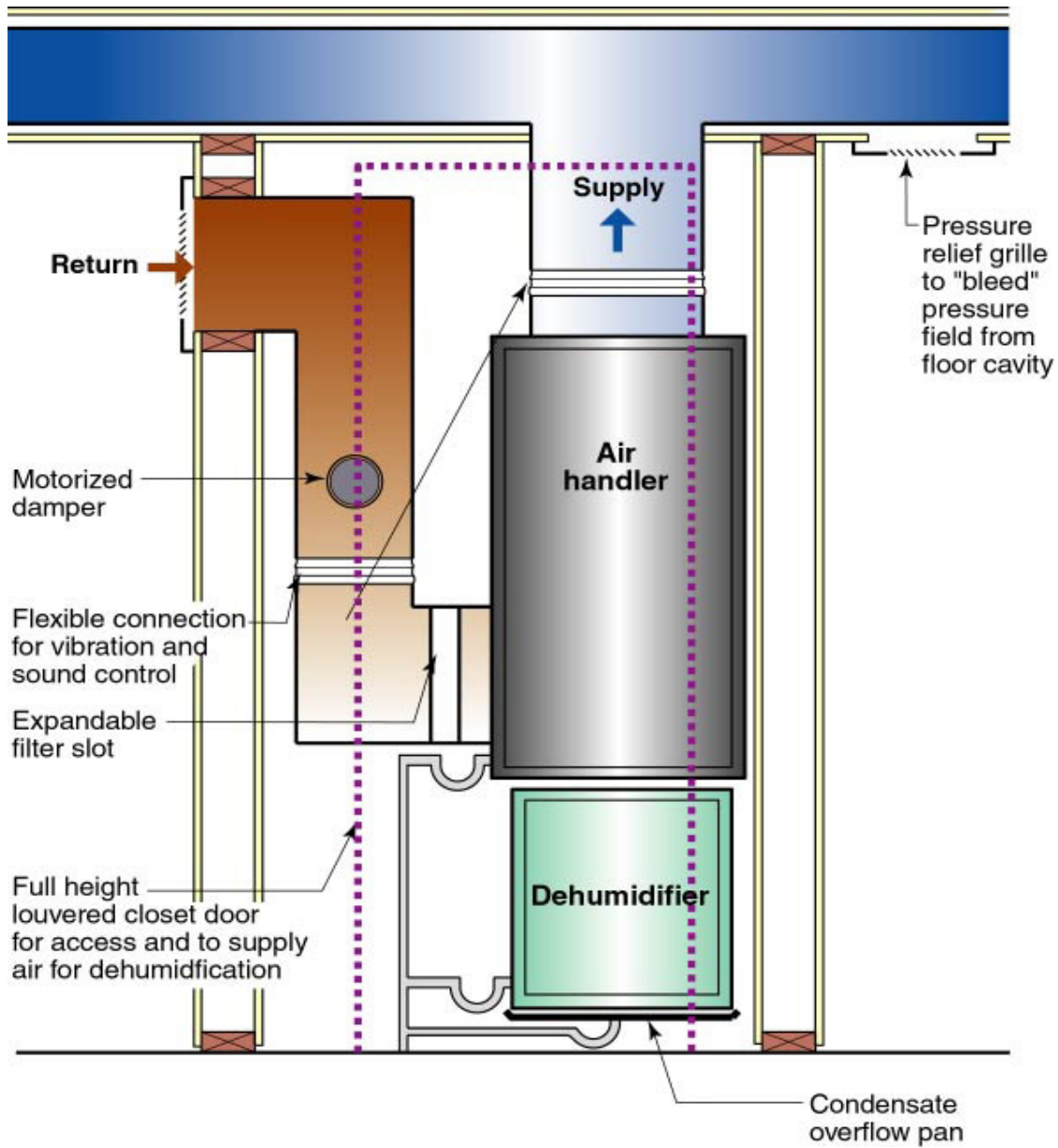

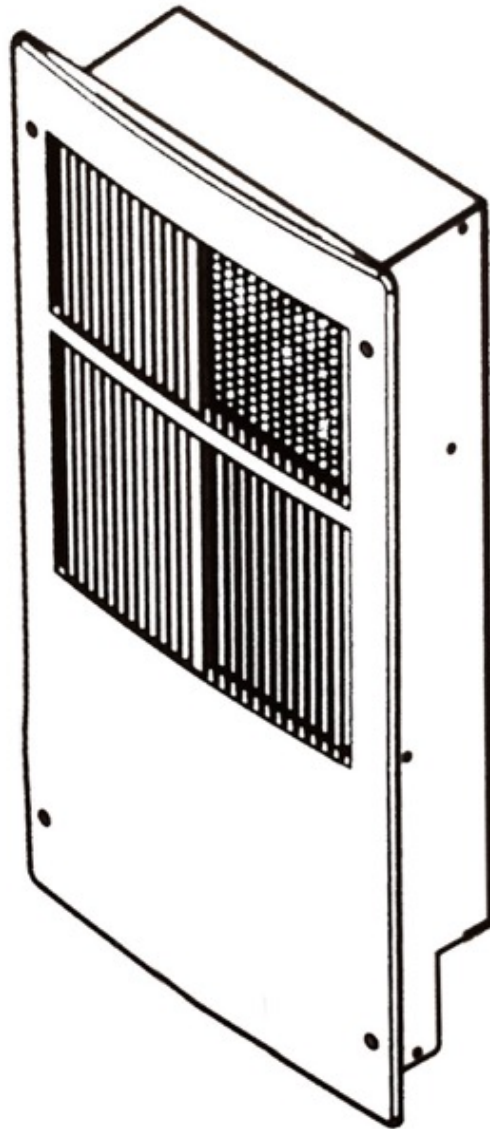

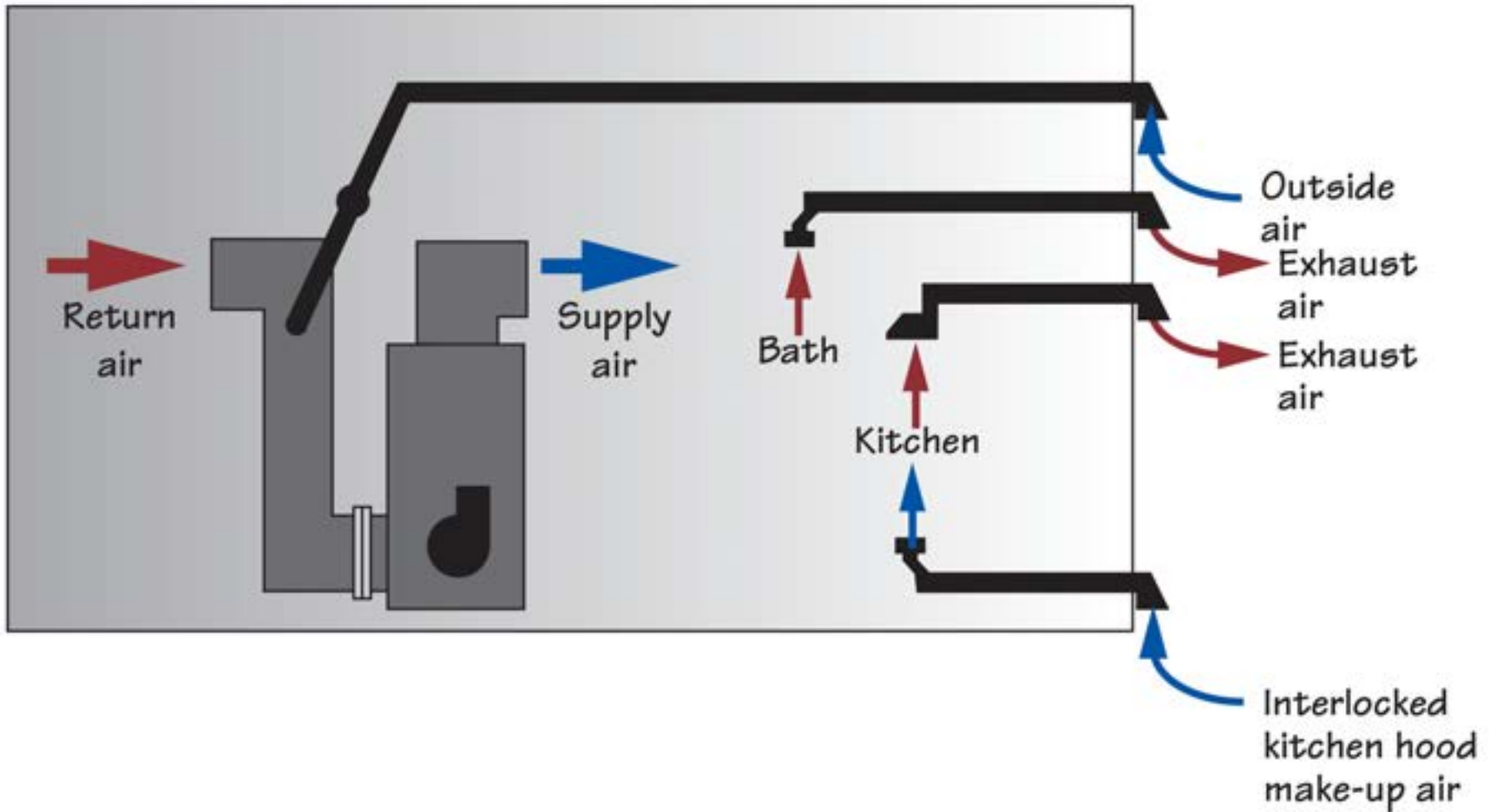

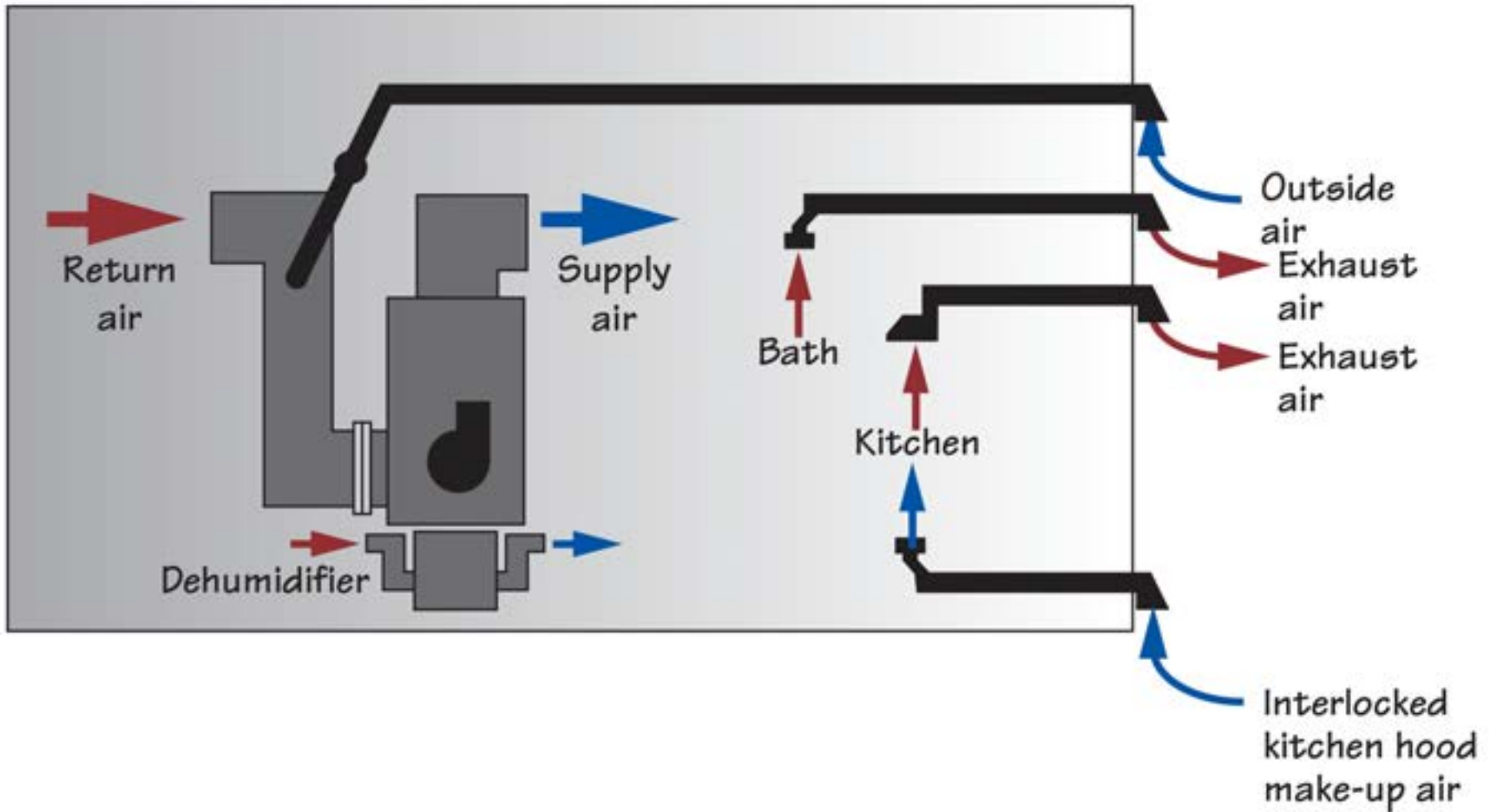

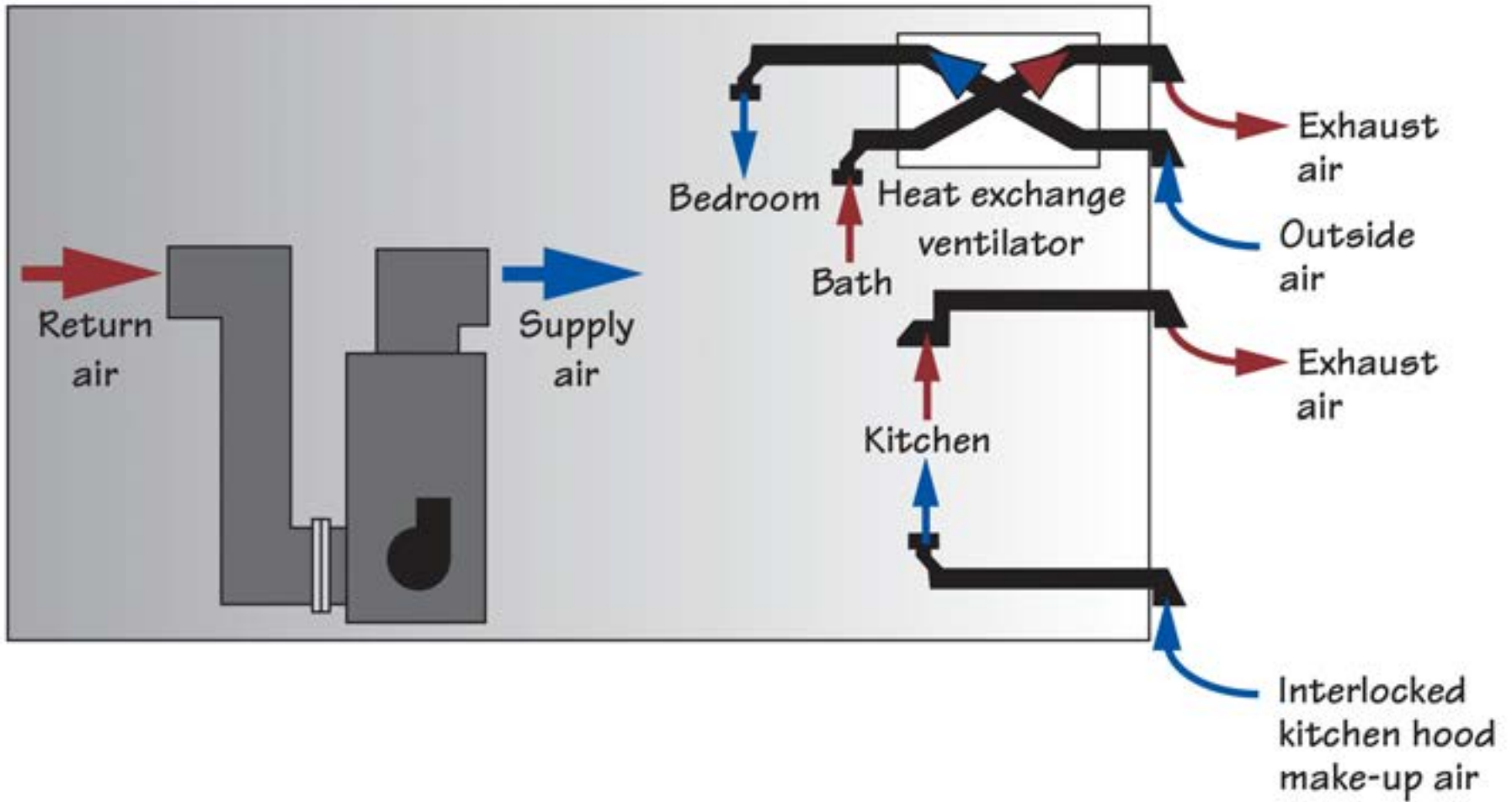

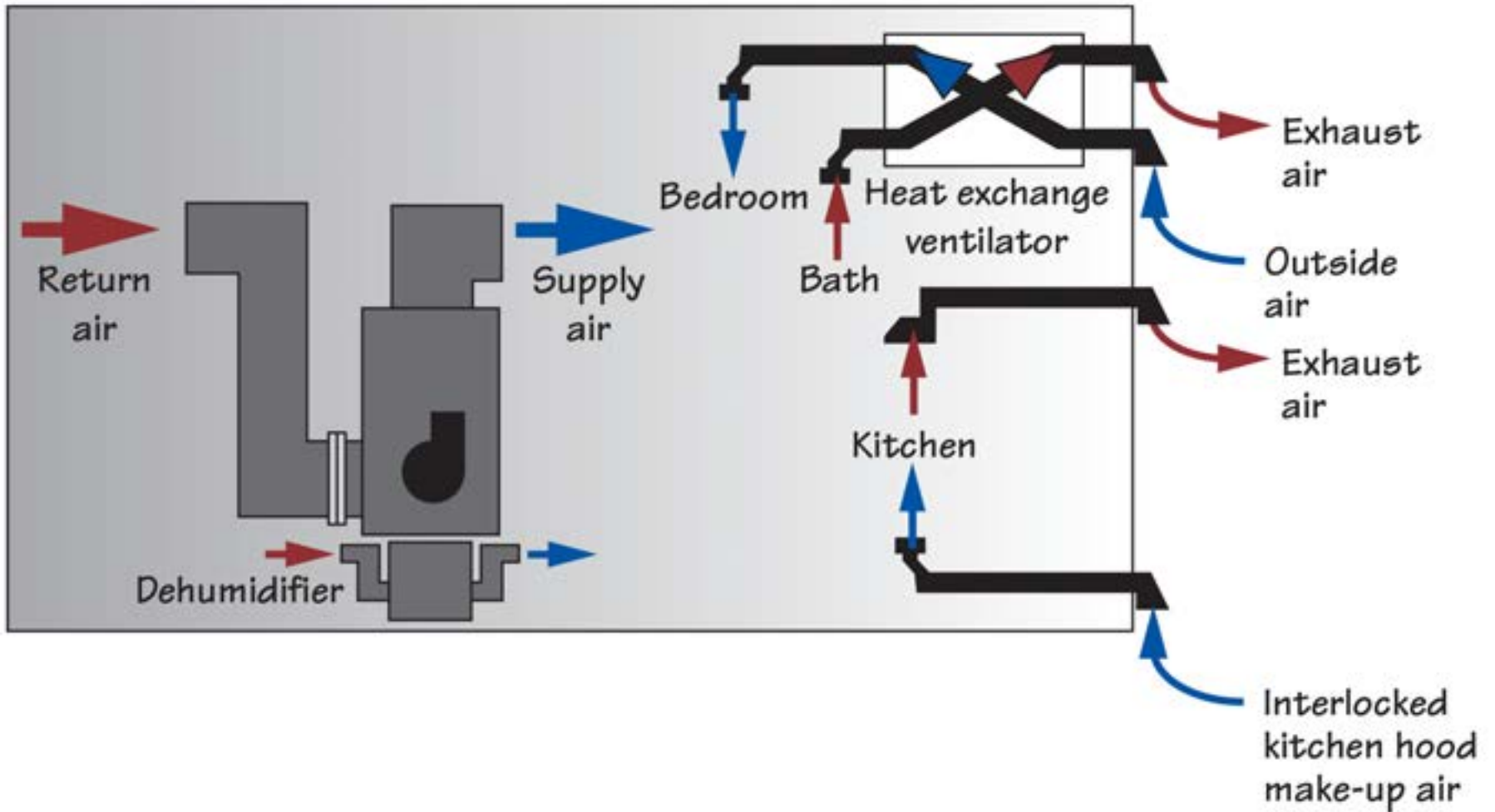

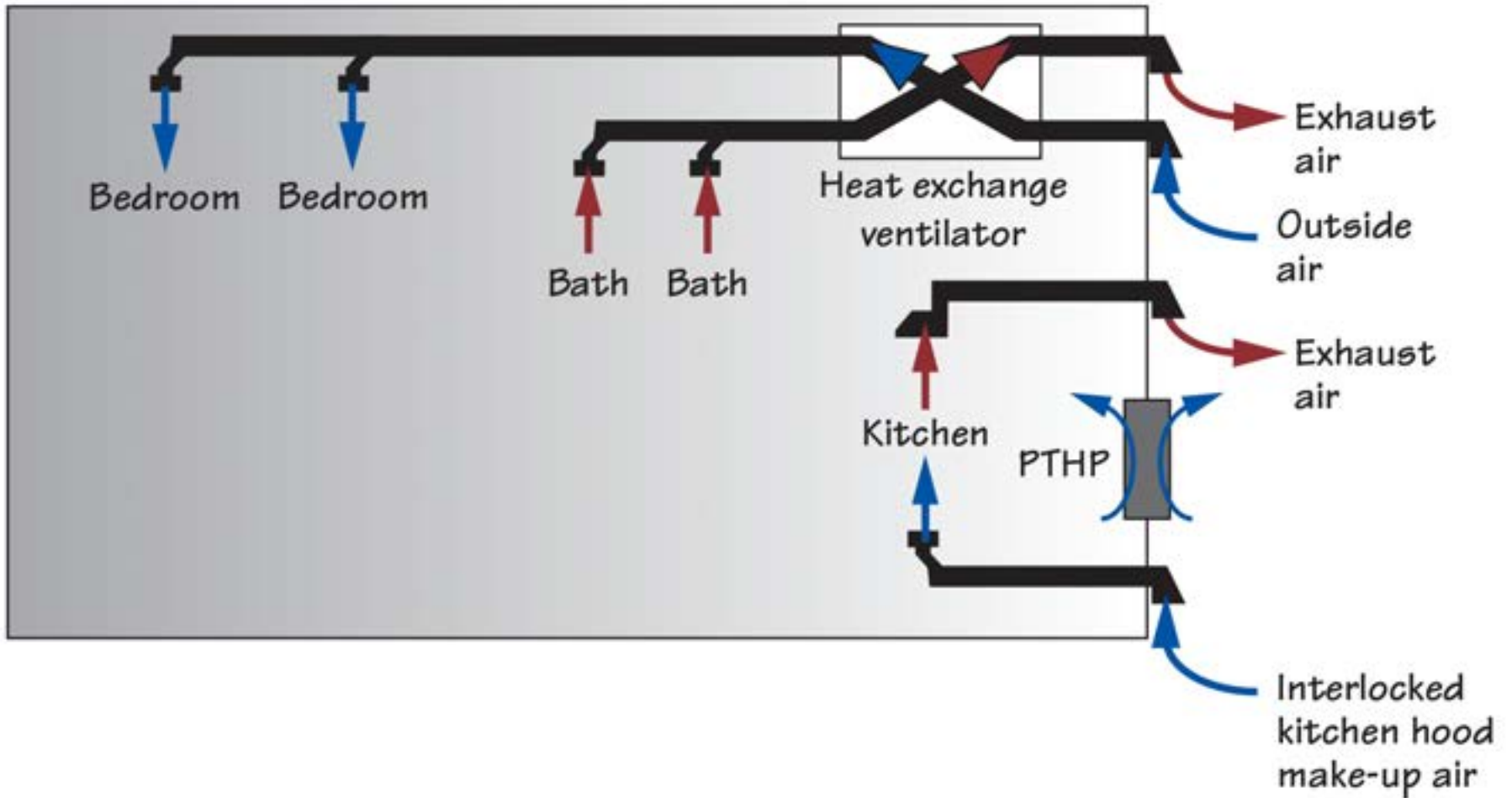

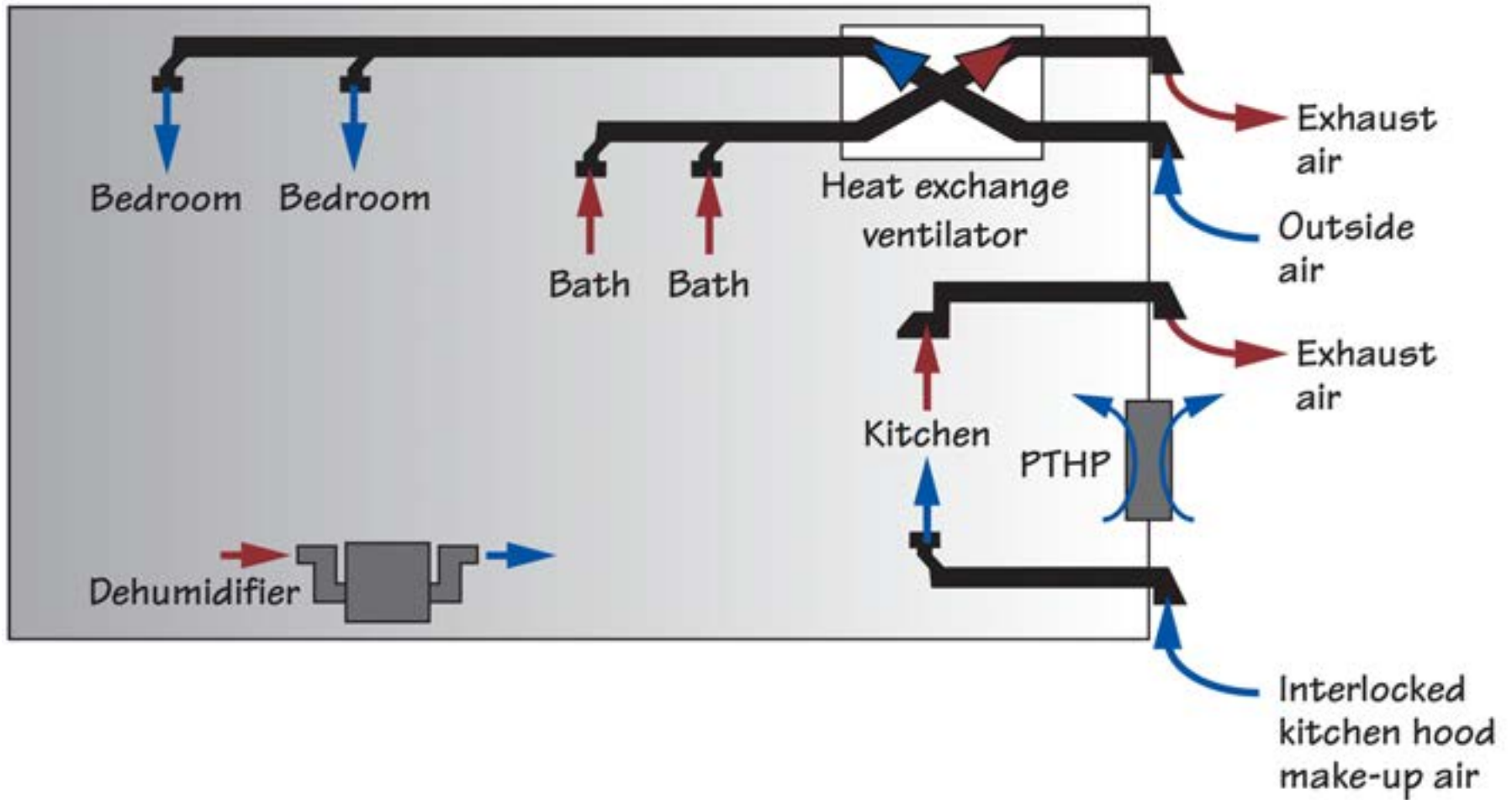

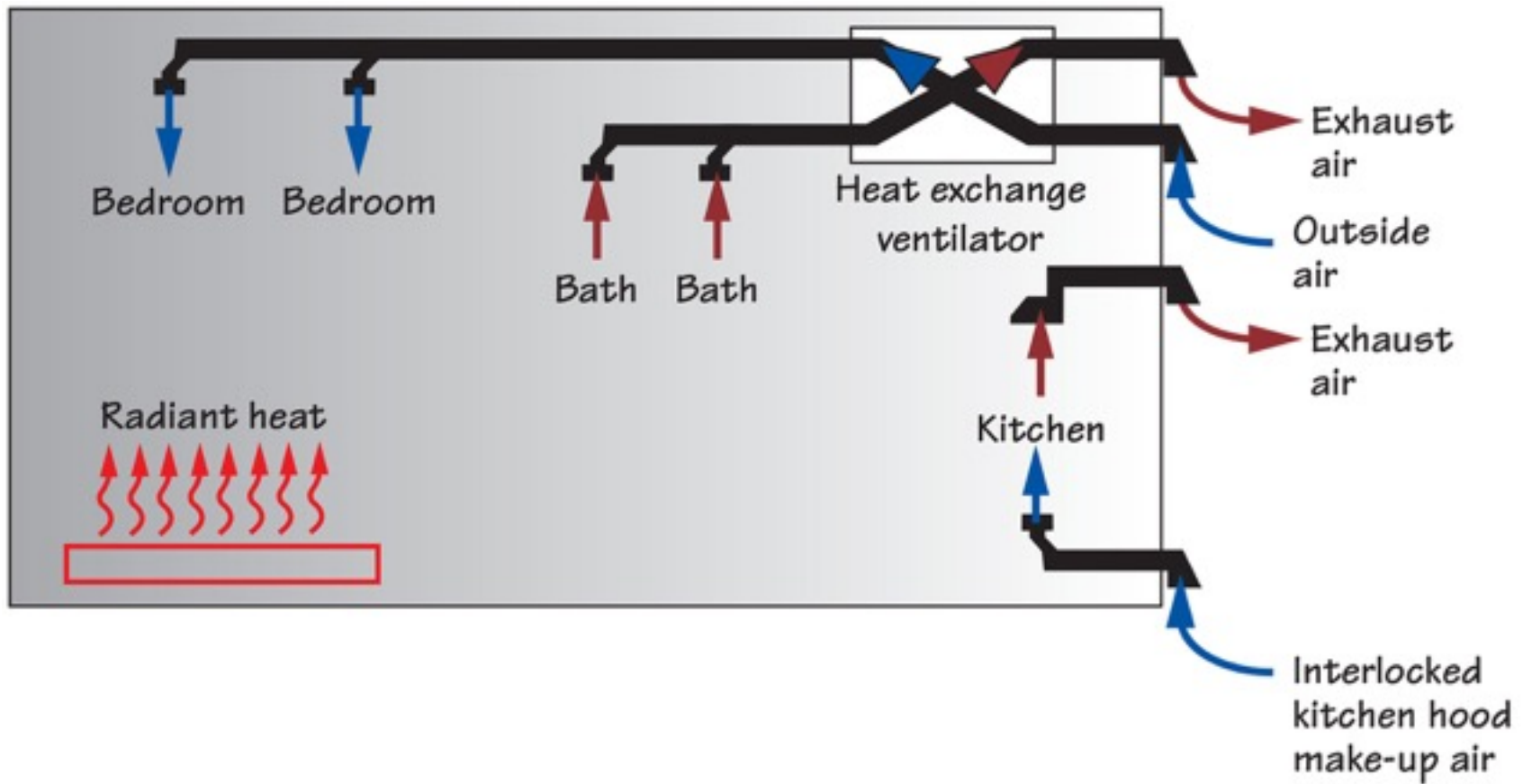

Mechanical Systems

Mechanical Systems

Cooling System To Make It Cold

Mechanical Systems

Cooling System To Make It Cold

Dehumidification System To Make It Dry

Mechanical Systems

Cooling System To Make It Cold

Dehumidification System To Make It Dry

Heating System To Make It Warm

Mechanical Systems

Cooling System To Make It Cold

Dehumidification System To Make It Dry

Heating System To Make It Warm

Energy Recovery System To Keep It Cold
and Dry and Warm and Comfortable

Mechanical Systems

Cooling System To Make It Cold

Dehumidification System To Make It Dry

Heating System To Make It Warm

Energy Recovery System To Keep It Cold
and Dry and Warm and Comfortable

Distribution System To Make It Uniform

Mechanical Systems

Cooling System To Make It Cold

Dehumidification System To Make It Dry

Heating System To Make It Warm

Energy Recovery System To Keep It Cold
and Dry and Warm and Comfortable

Distribution System To Make It Uniform

Range Hoods Are A Special Kind of Hell

Don't Try to Combine Them.....

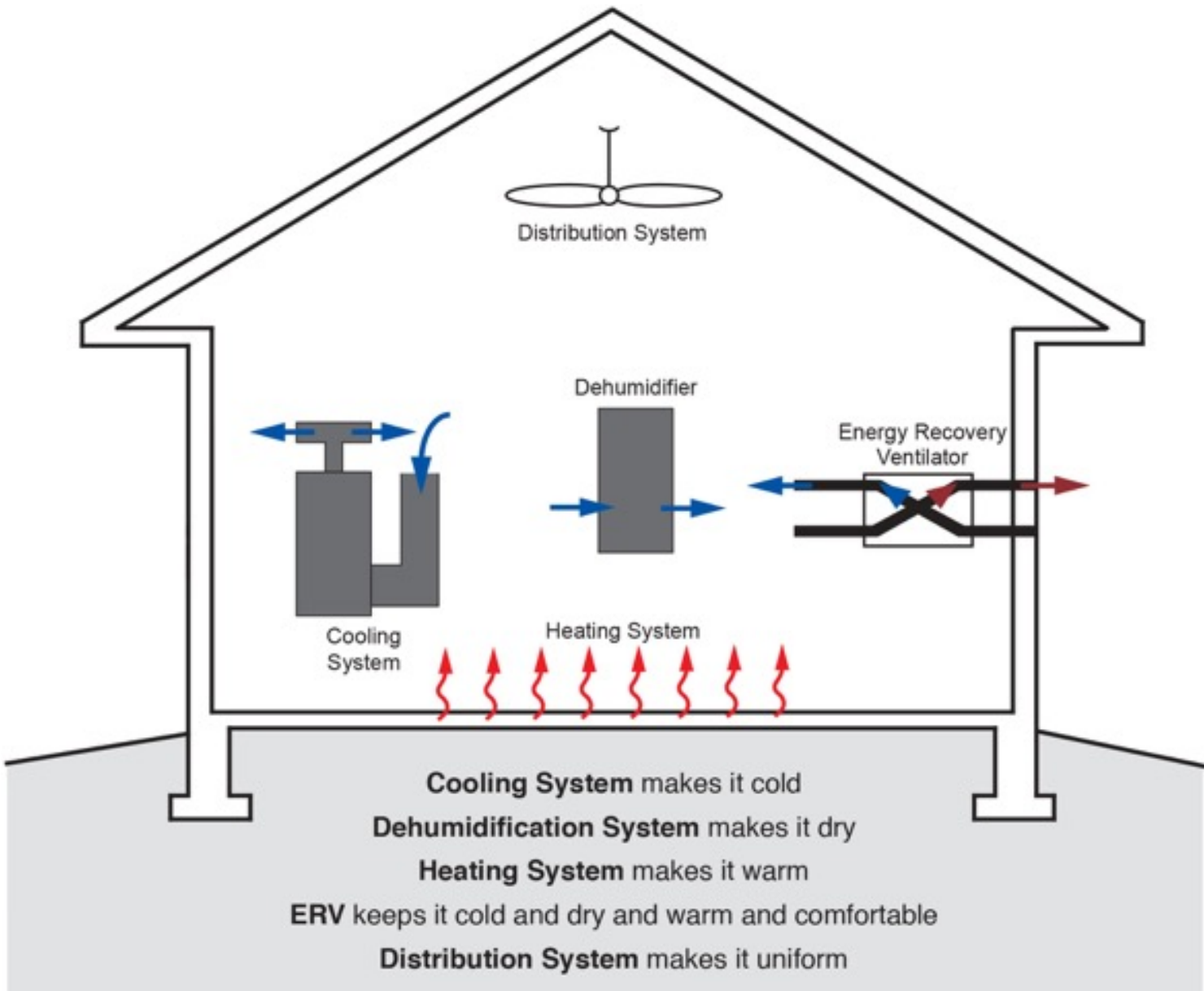

Kitchen Exhaust Hoods

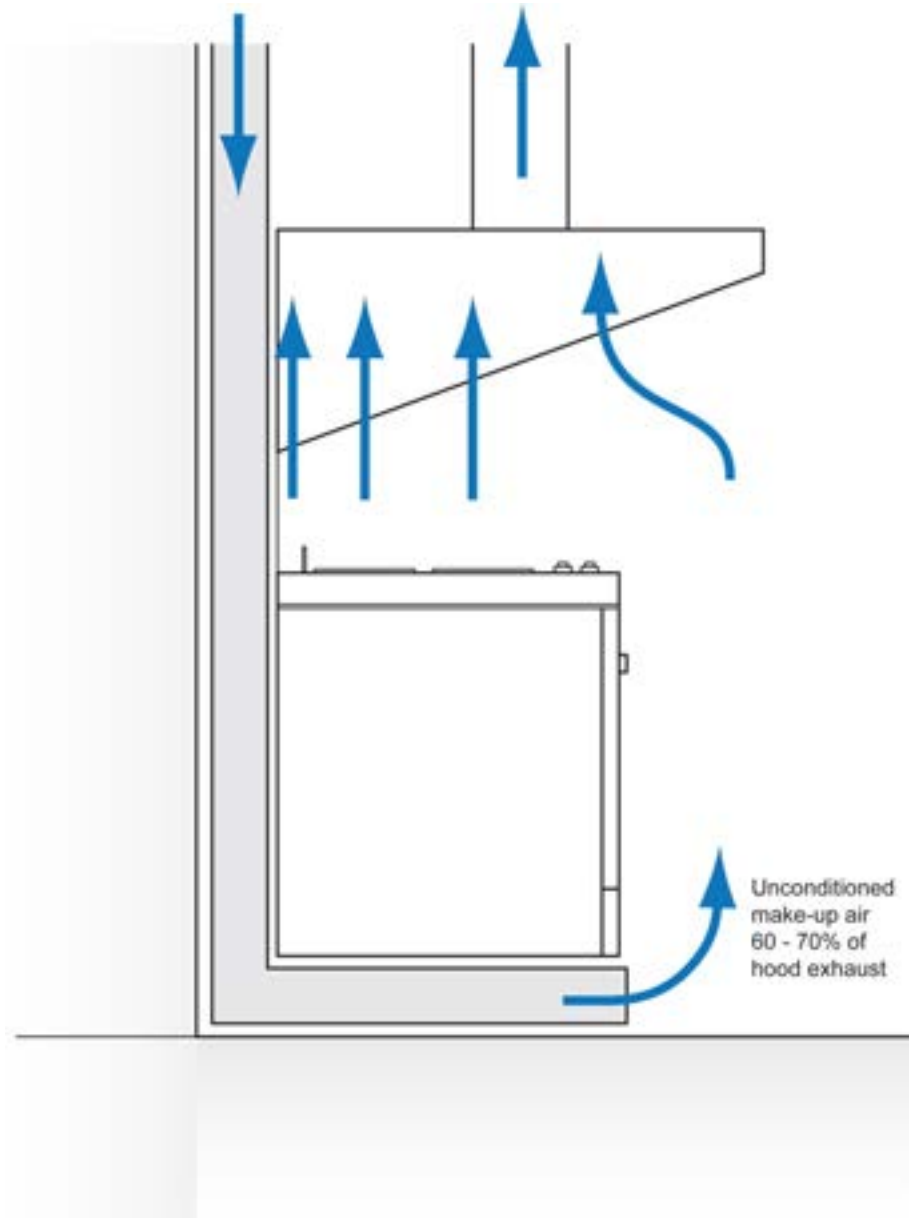



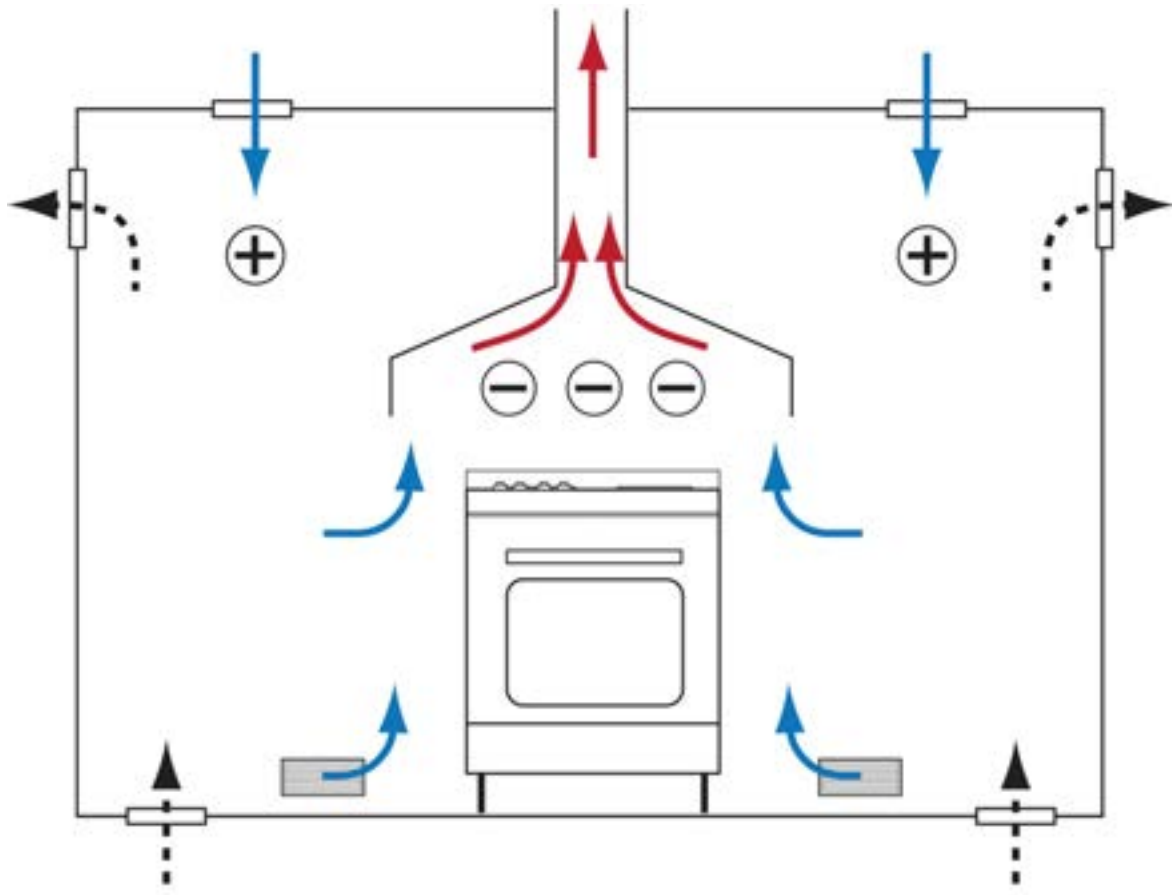

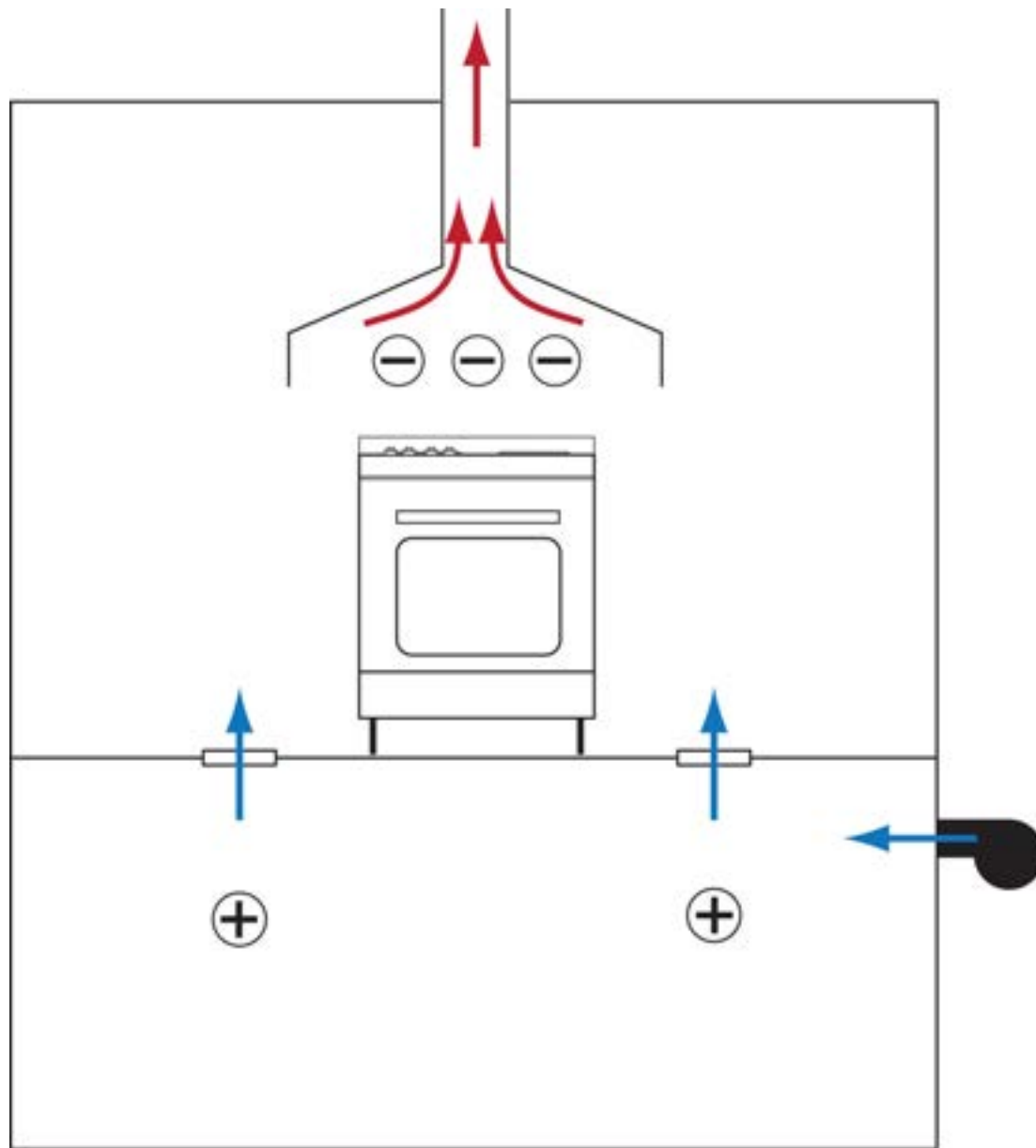







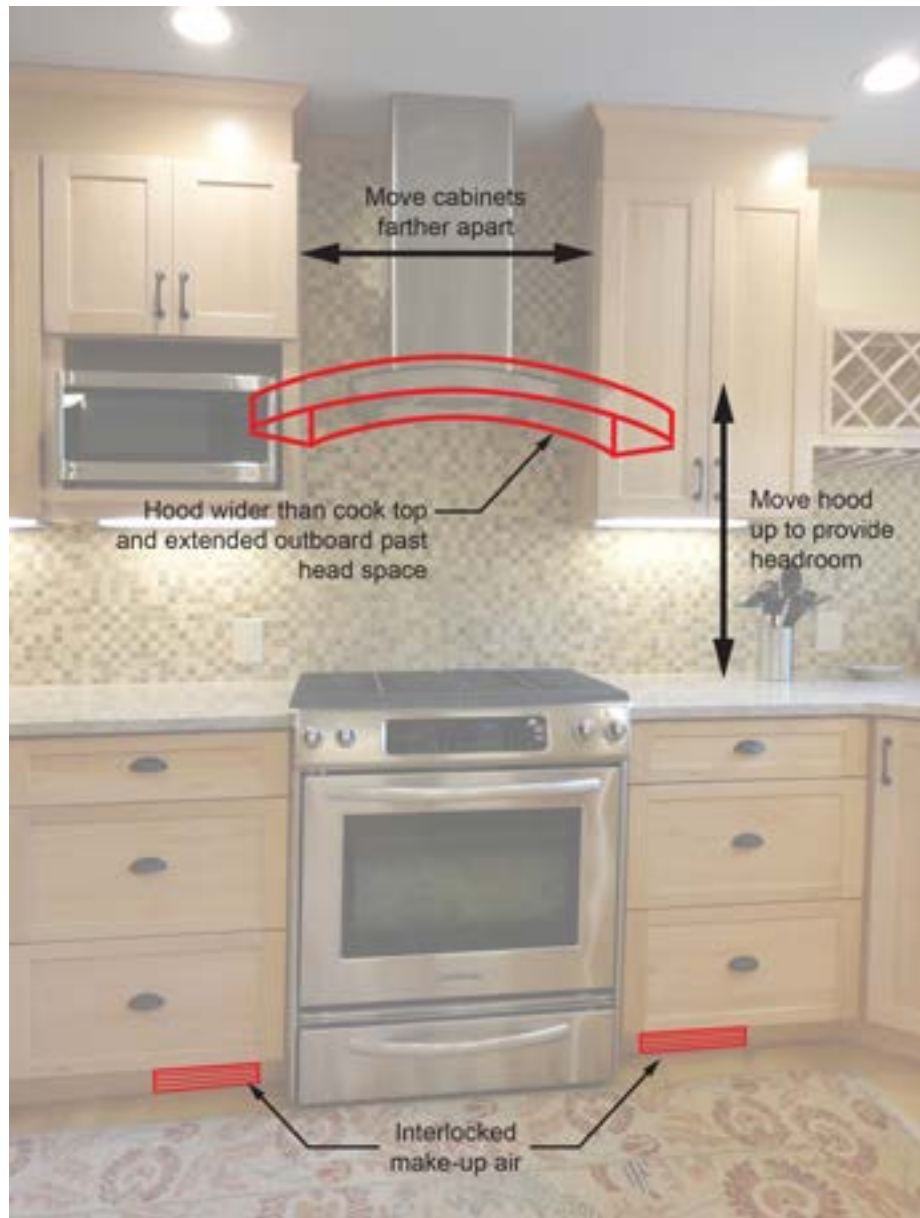



Clothes Dryers





Fireplaces









