

Joseph Lstiburek, Ph.D., P.Eng, ASHRAE Fellow

# Building Science

---

## Towering Inferno

[www.buildingscience.com](http://www.buildingscience.com)

# Setting The Stage

Grenfell Tower

North Kensington, United Kingdom

June, 2017









# Focus is on Cladding



Focus is on Cladding  
Effective Compartmentalization  
Detection and Alarm Systems  
Sprinkler Systems  
Egress











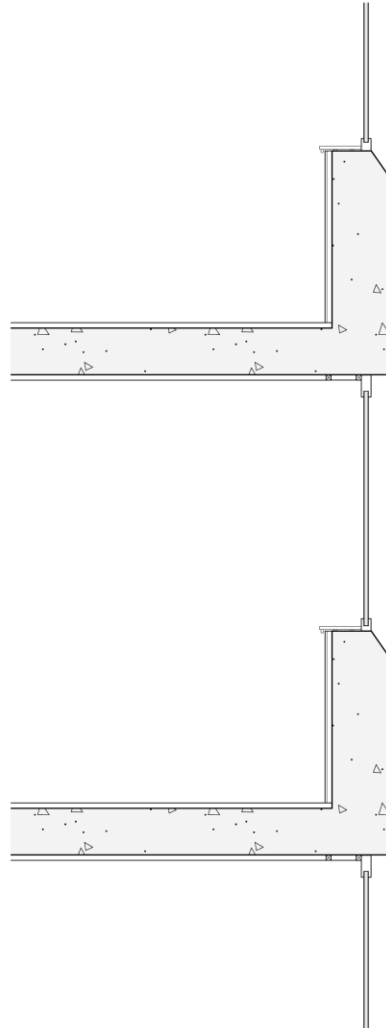

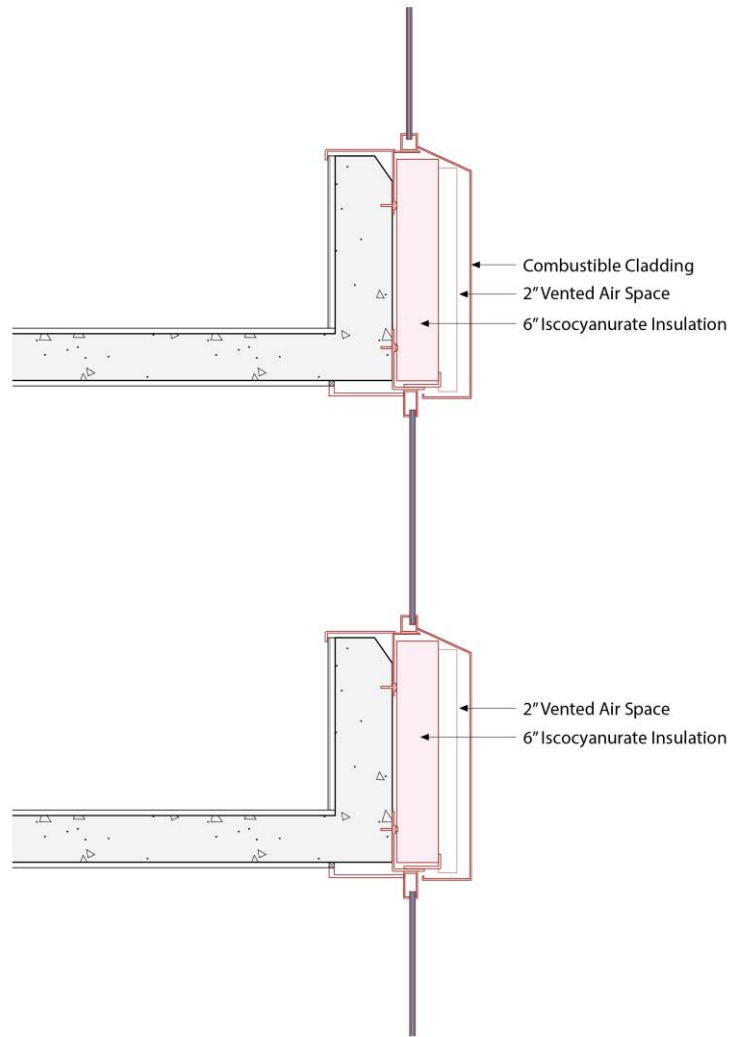

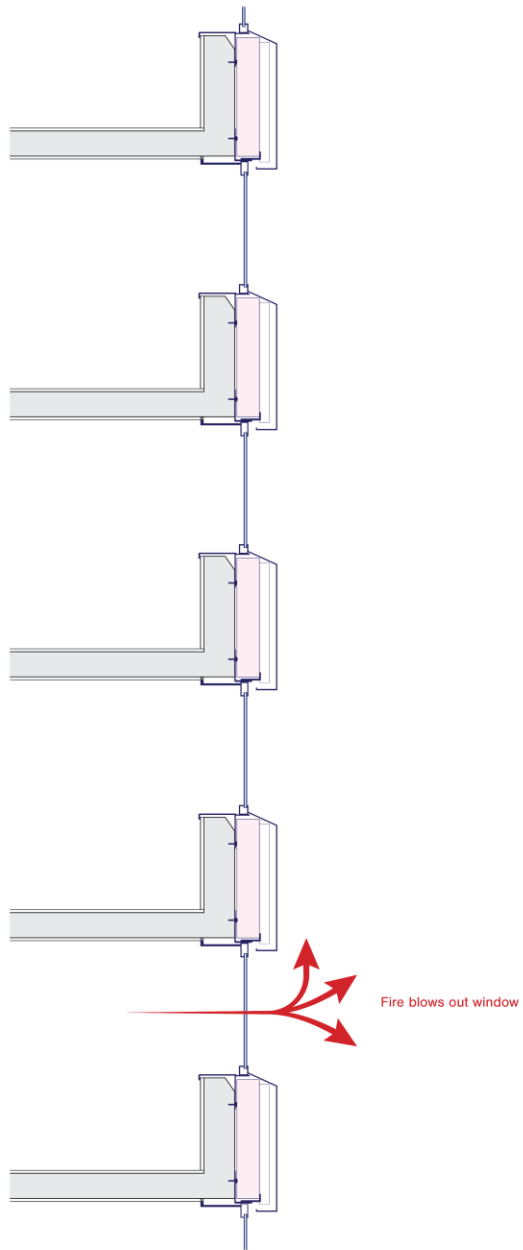

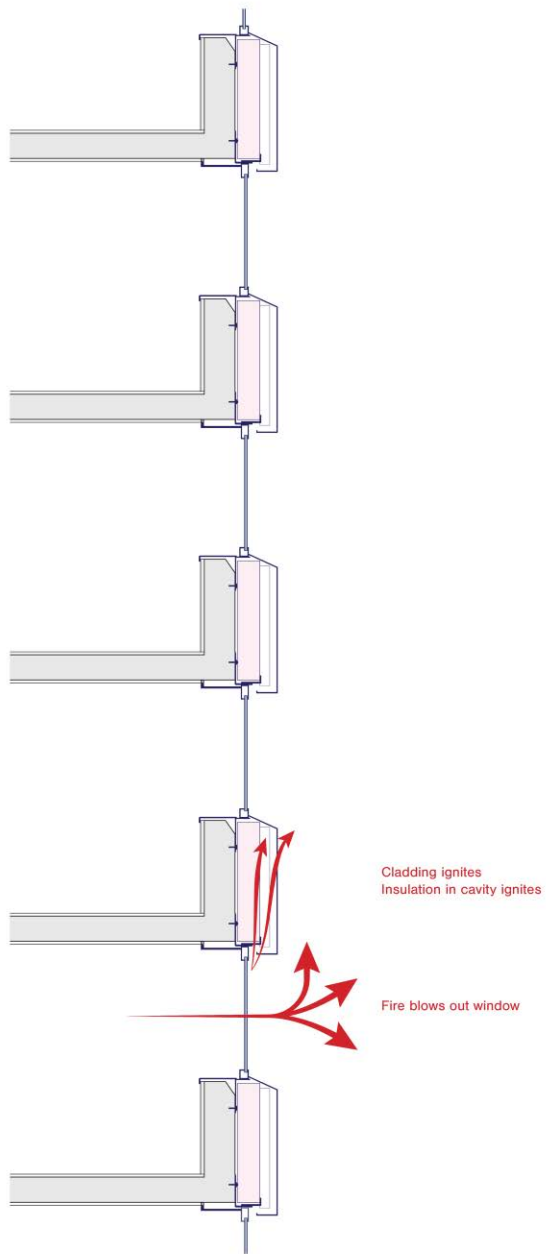

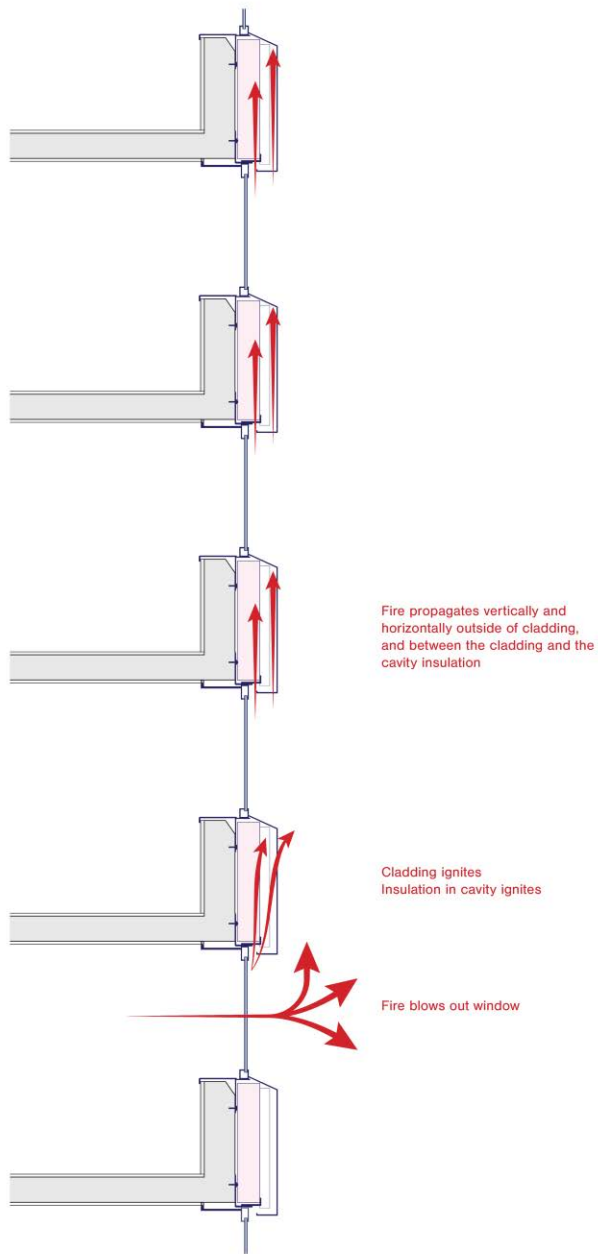

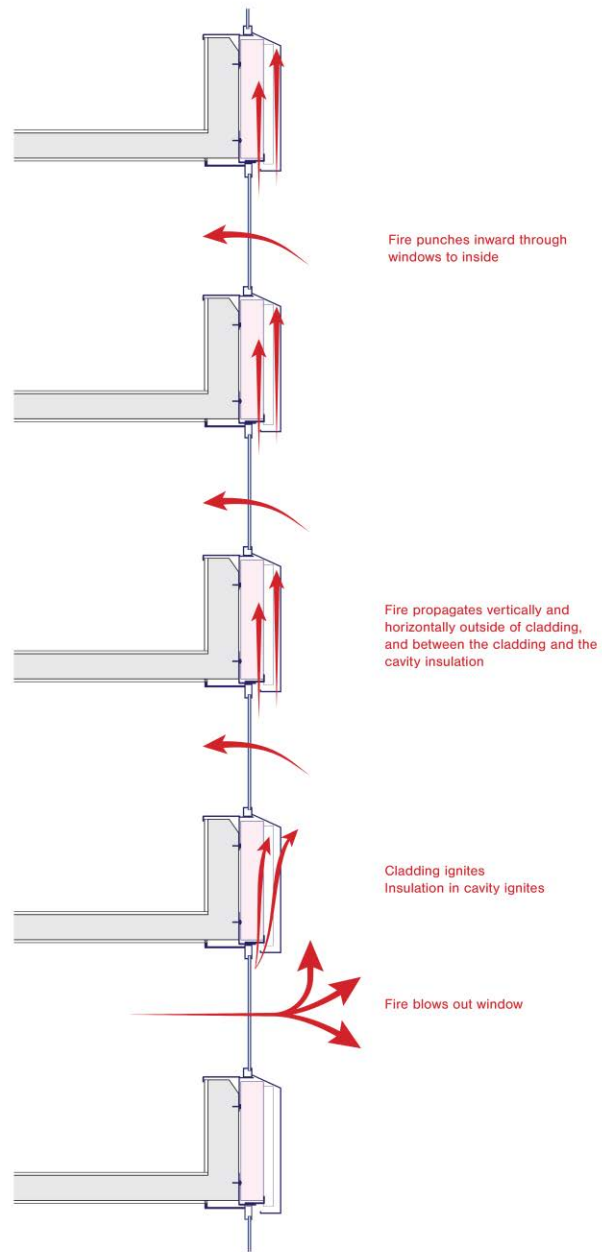

Fire punches inward through windows to inside

Fire propagates vertically and horizontally outside of cladding, and between the cladding and the cavity insulation

Cladding ignites  
Insulation in cavity ignites

Fire blows out window

Dubai Address Hotel  
Dubai, United Arab Emirates  
January, 2015







# Mermoz Roubaix, France

## May 2012



Tamweel Tower

Dubai, United Arab Emirates

November, 2012







Al Nahda Tower  
Sharjah, United Arab Emirates  
April, 2012







Polat Tower  
Istanbul, Turkey  
July, 2012





Dubai Torch Tower  
Dubai, United Arab Emirates  
August, 2017

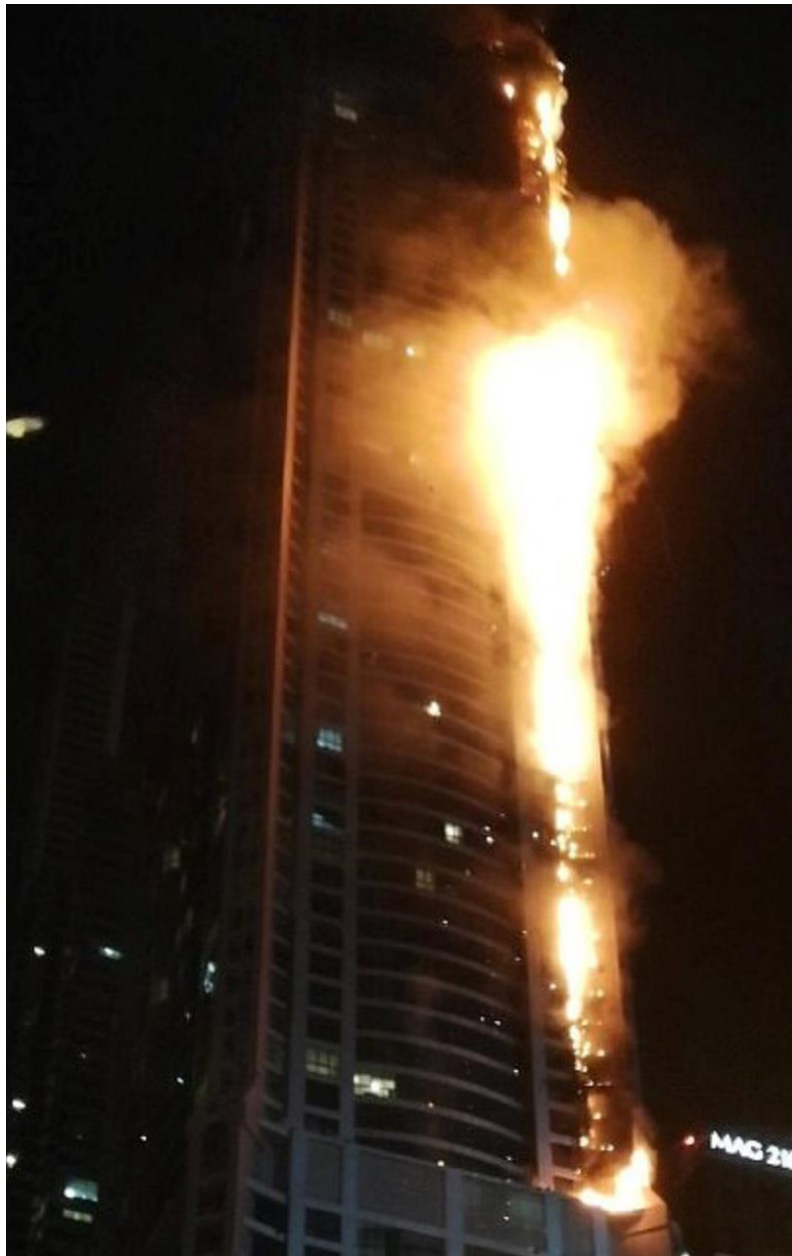





Thorn House Hotel  
Rostov-on-Don, Grozny, Chechnya  
September, 2017







Marco Polo Apartments  
Honolulu, Hawaii  
July, 2017









# Cladding Attachment





# Hooker Chemical Building Niagara Falls, New York







John E. Jaqua Academic Center  
University of Oregon,  
Eugene, Oregon









# Stattdor Building Dusseldorf, Germany







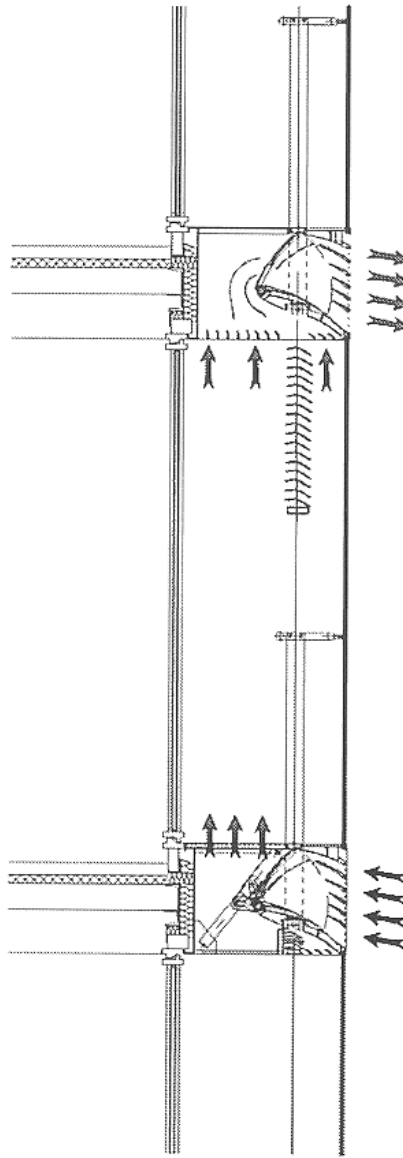

# Where I Grew Up























# Rain





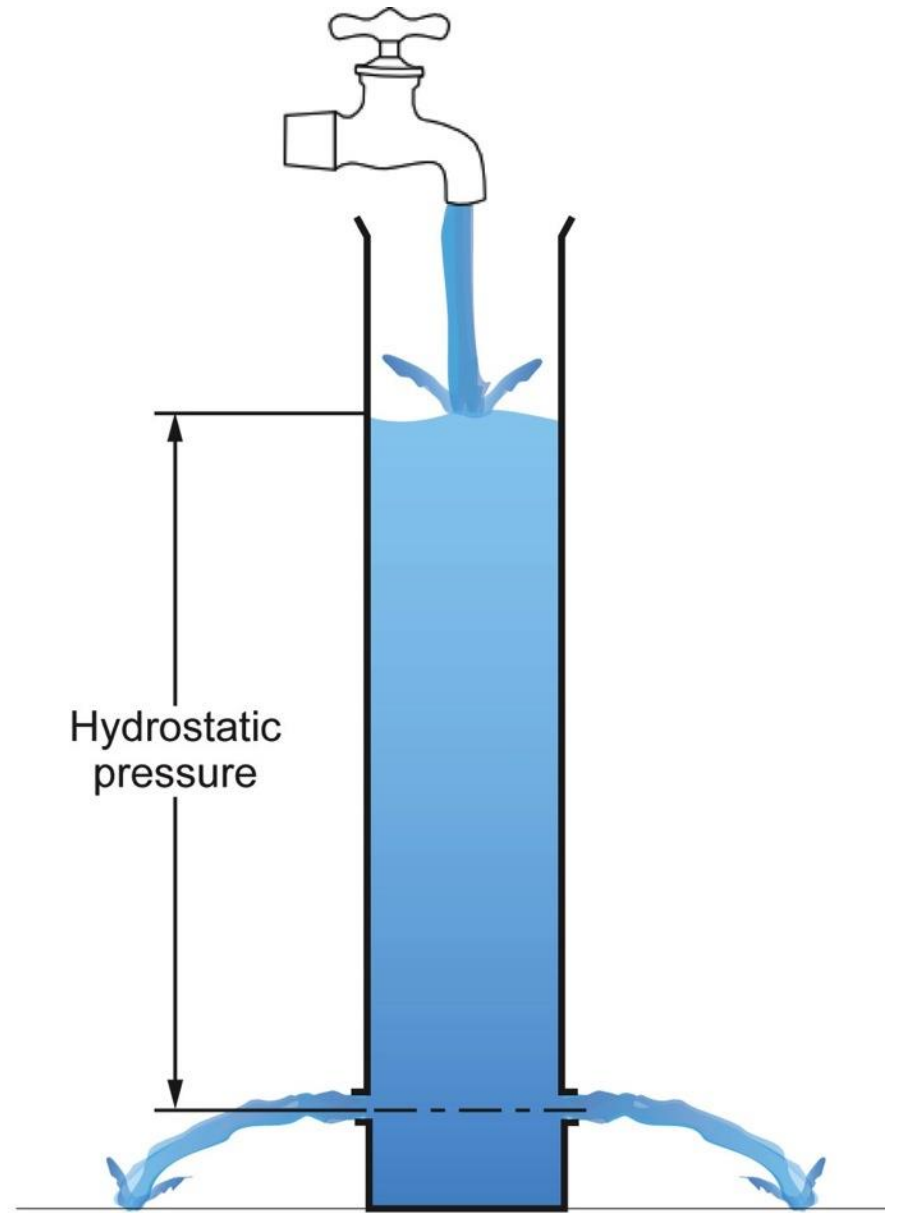
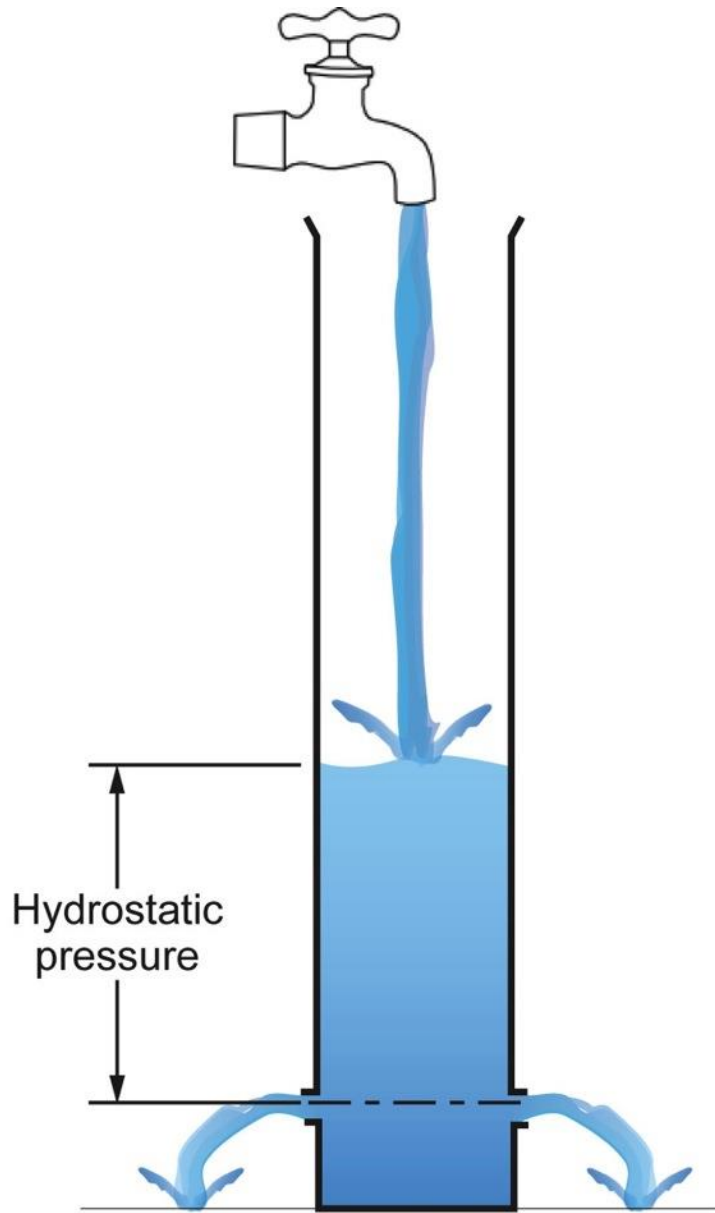





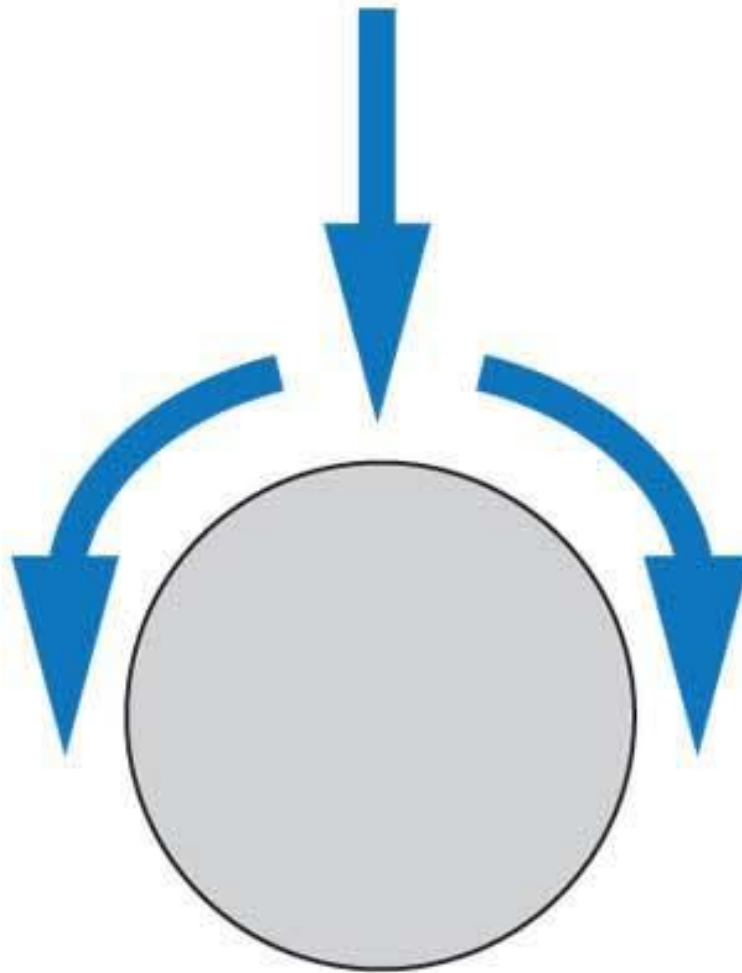

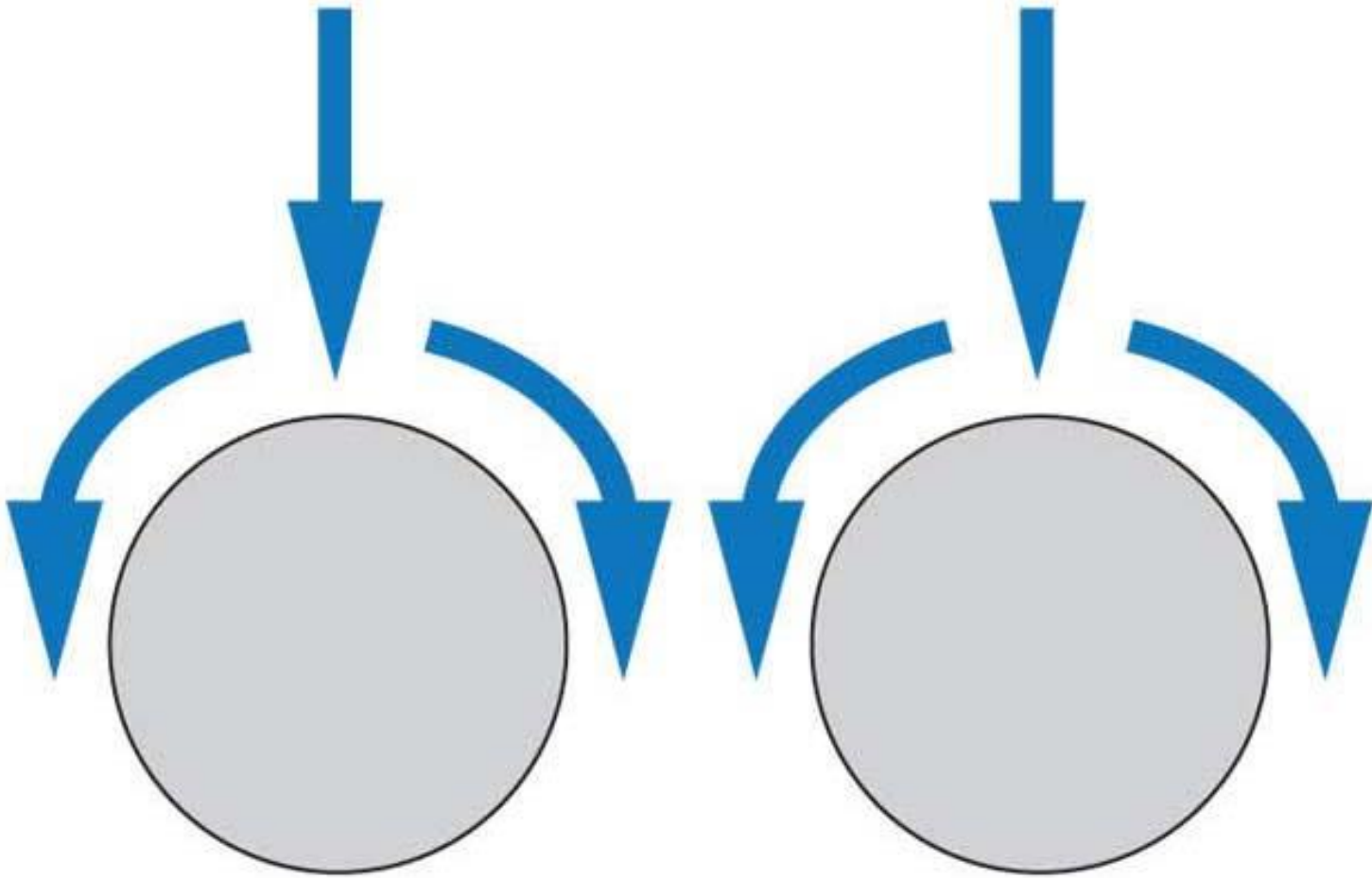

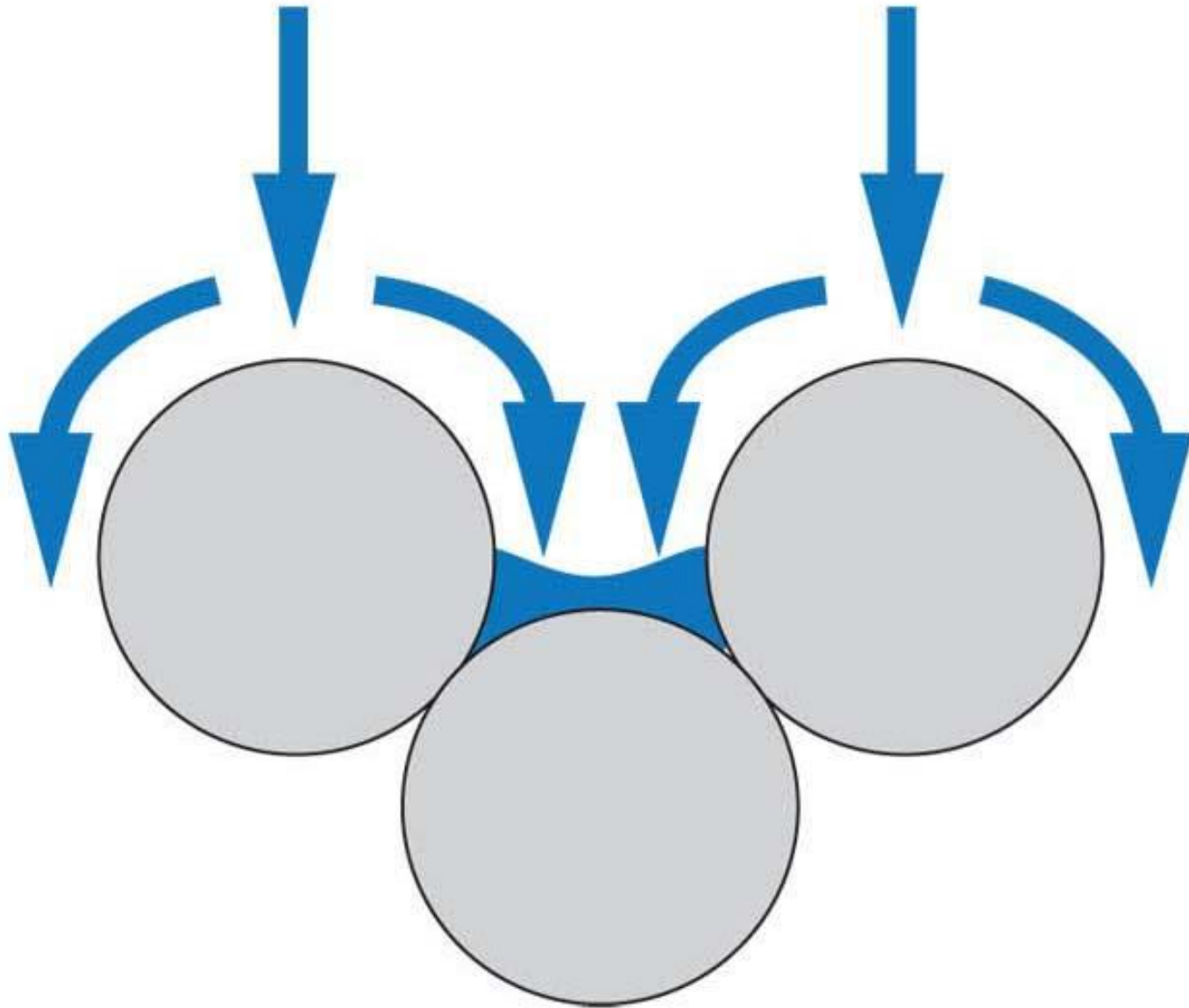

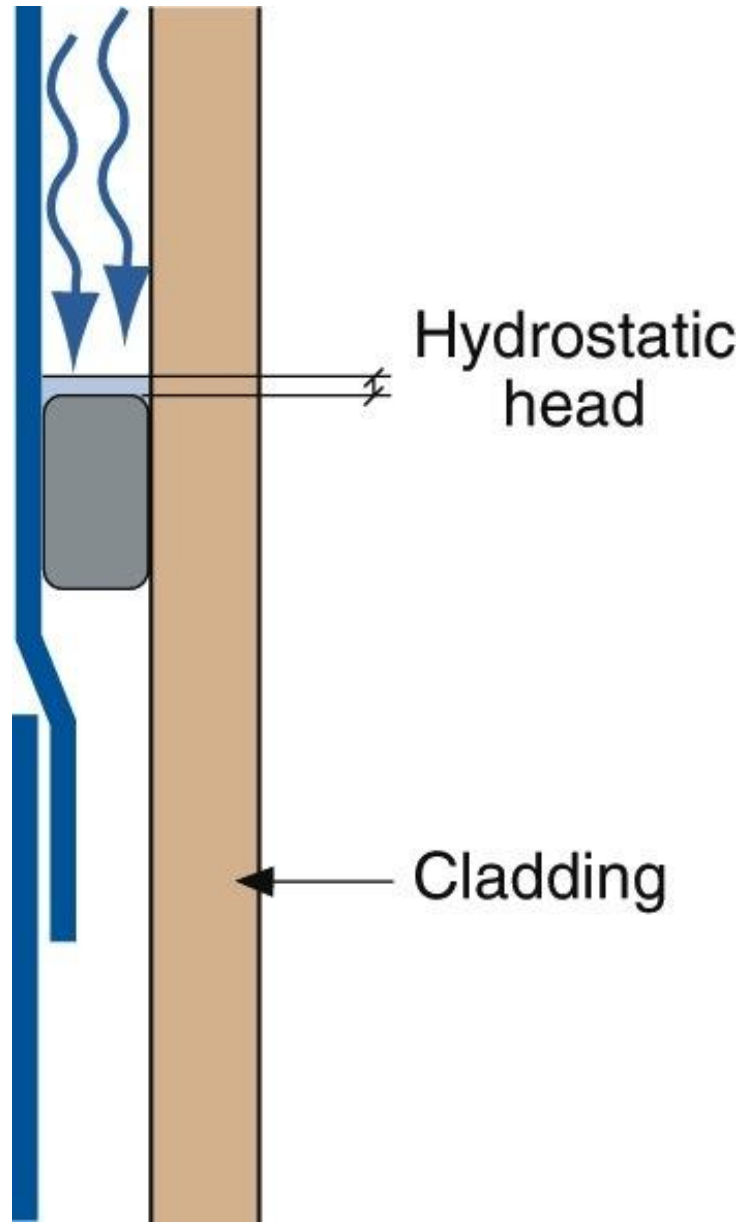



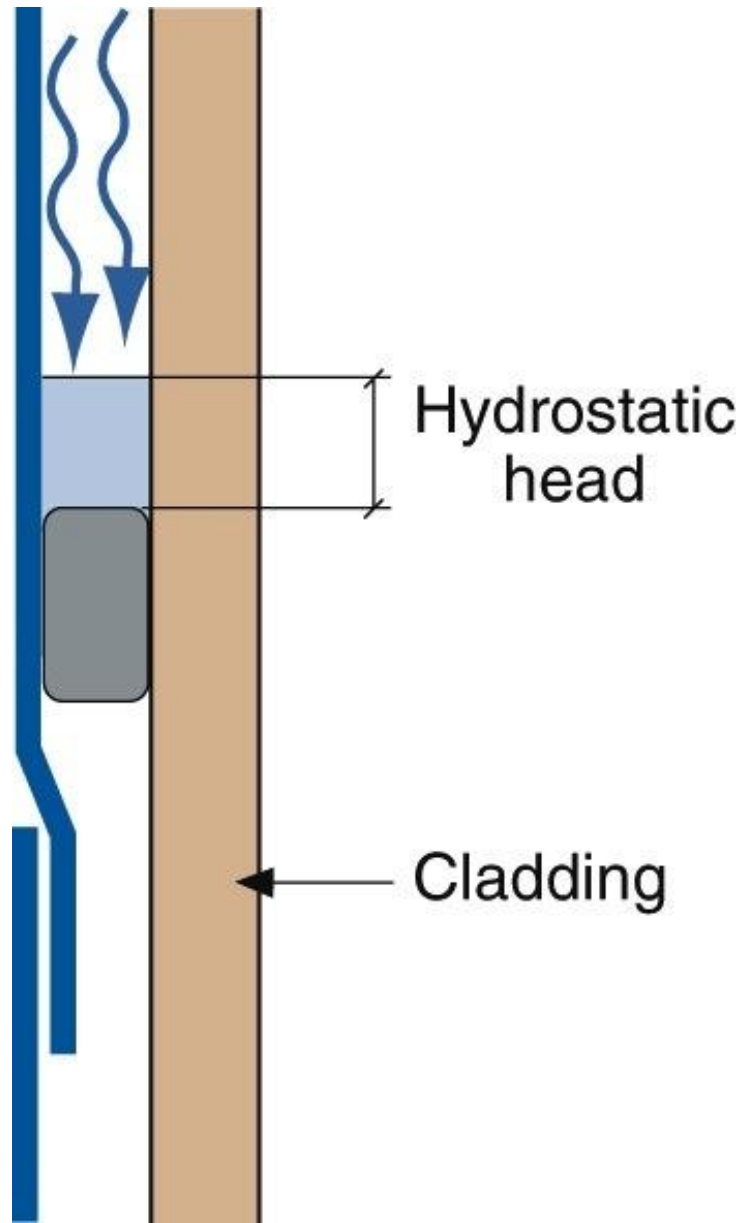

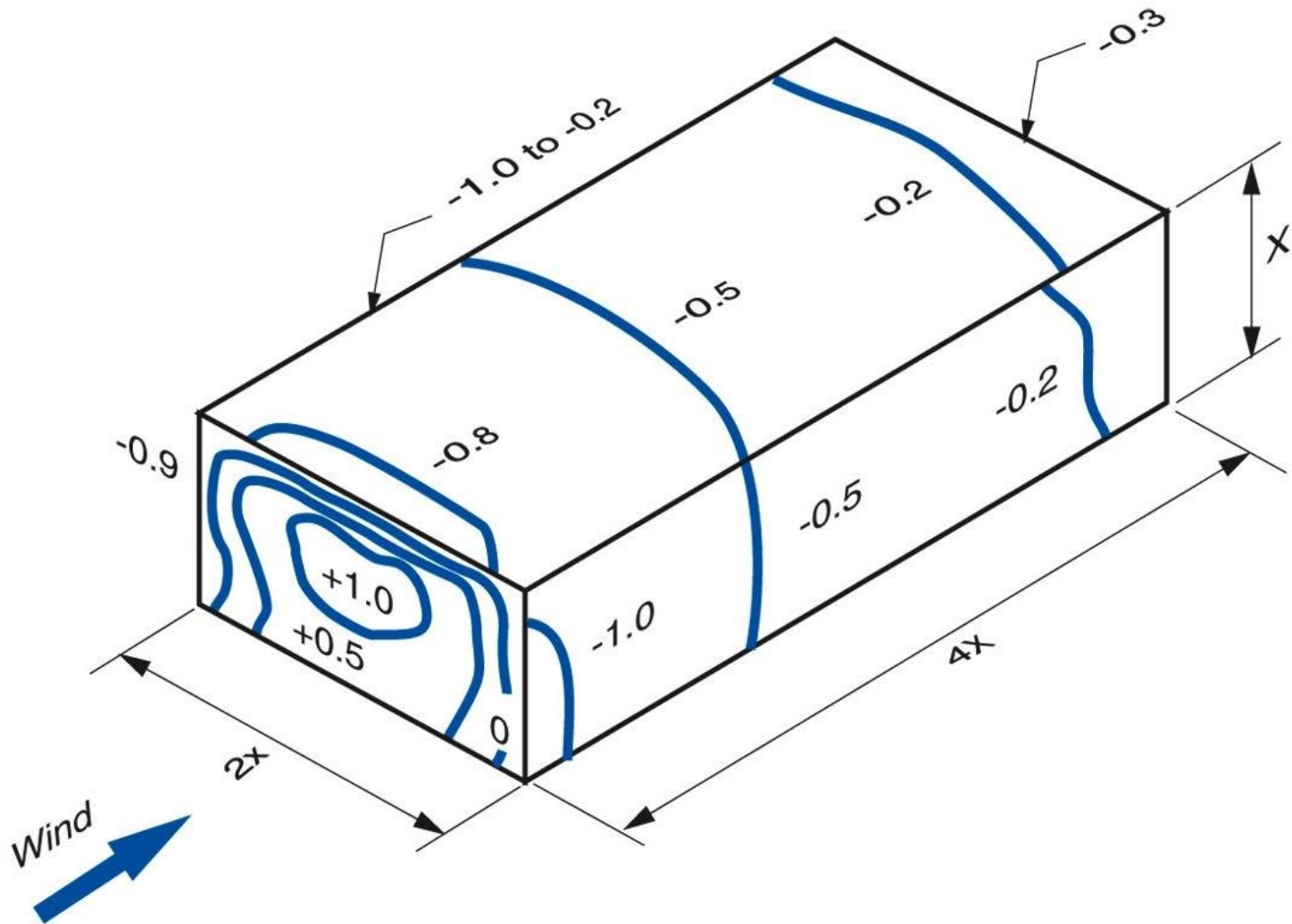

### Pascals    mph

50 Pa =	20 mph
100 Pa =	30 mph
150 Pa =	35 mph
250 Pa =	45 mph
500 Pa =	65 mph
1,000 Pa =	90 mph

### Wind Speed (mph) vs. Stagnation Pressure (Pa)

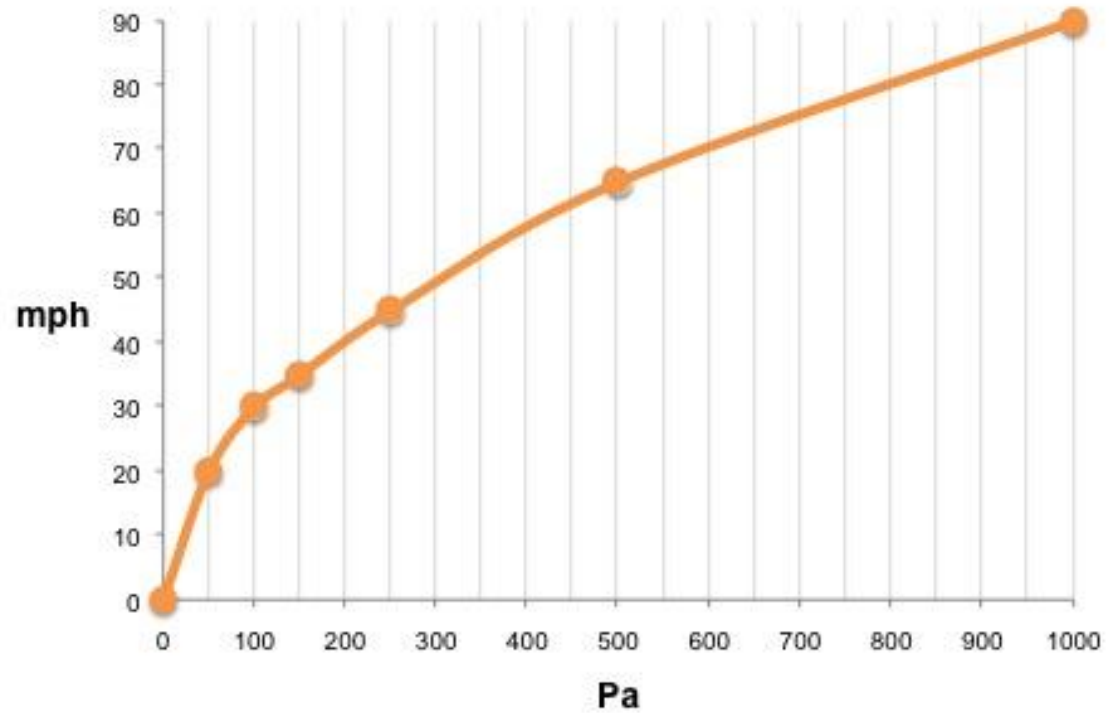

# Rain Screen



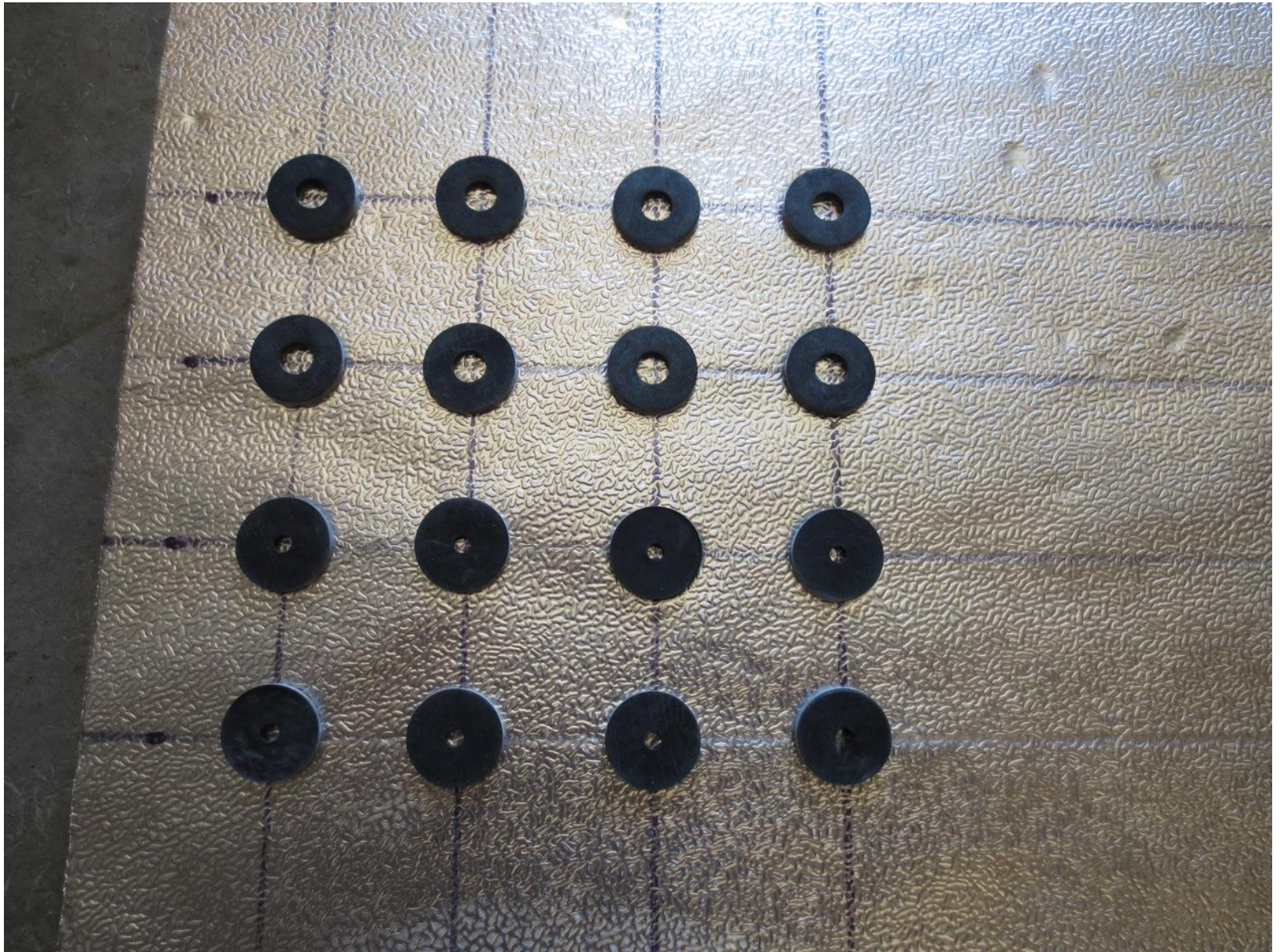









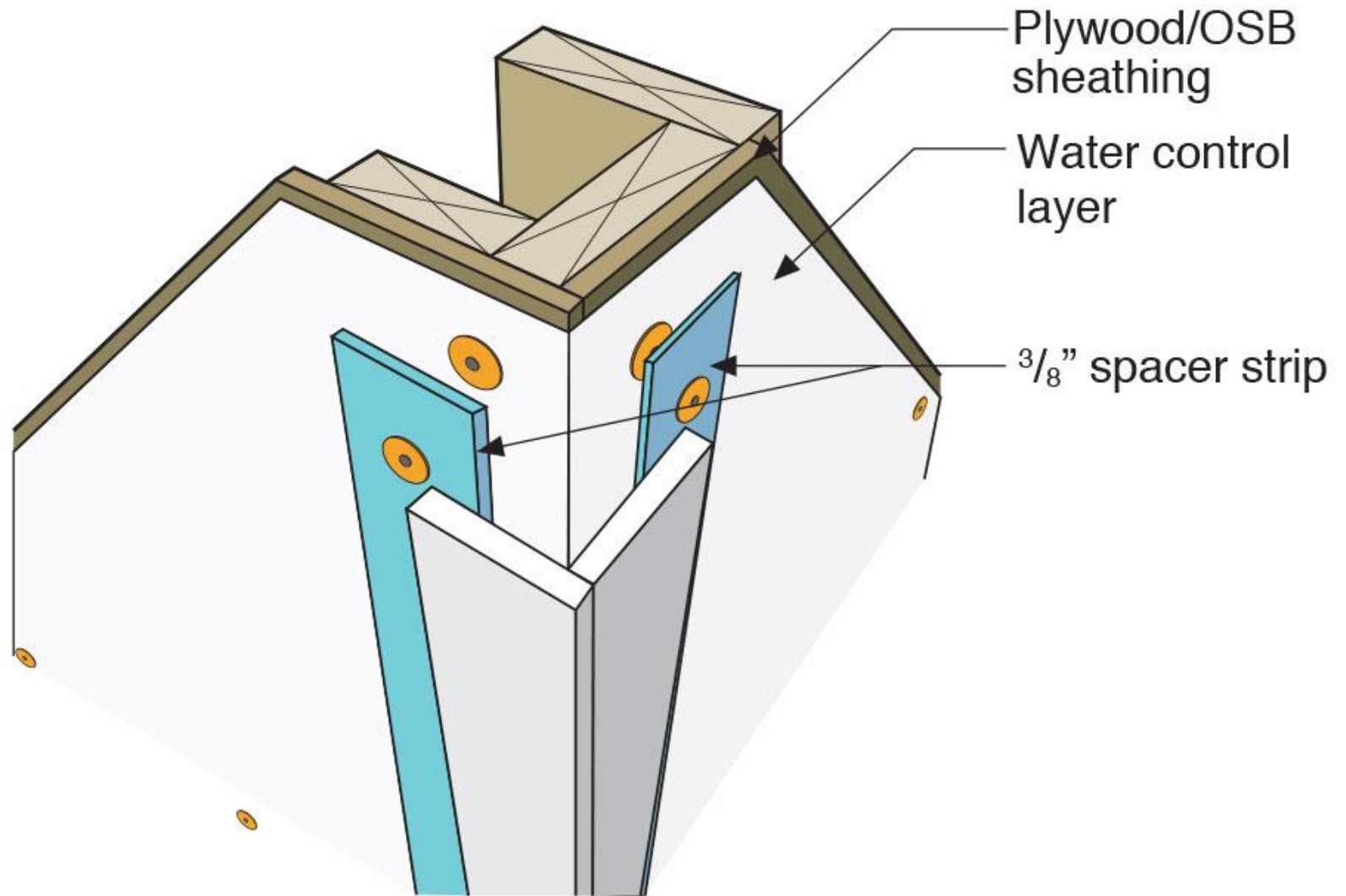









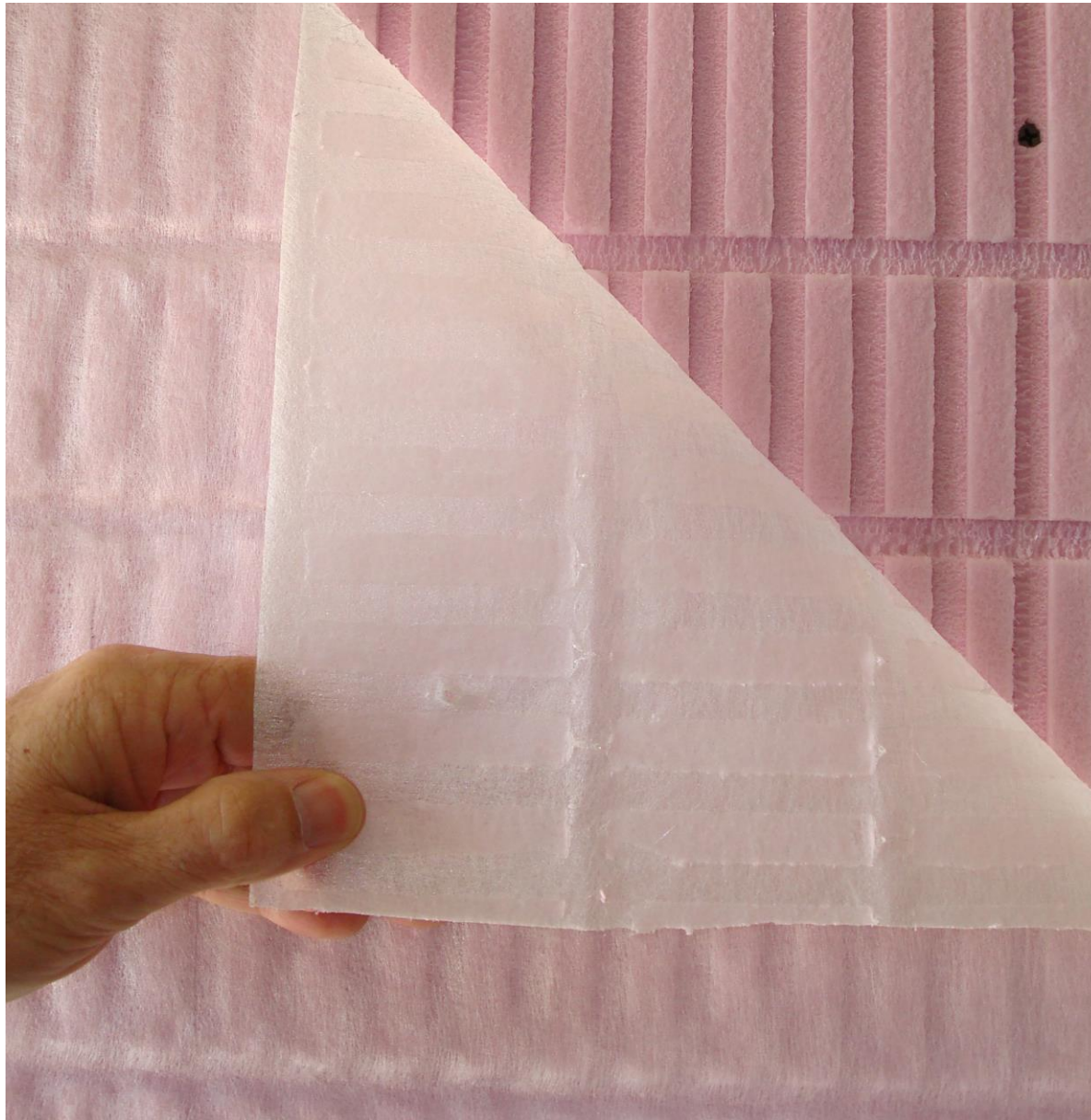

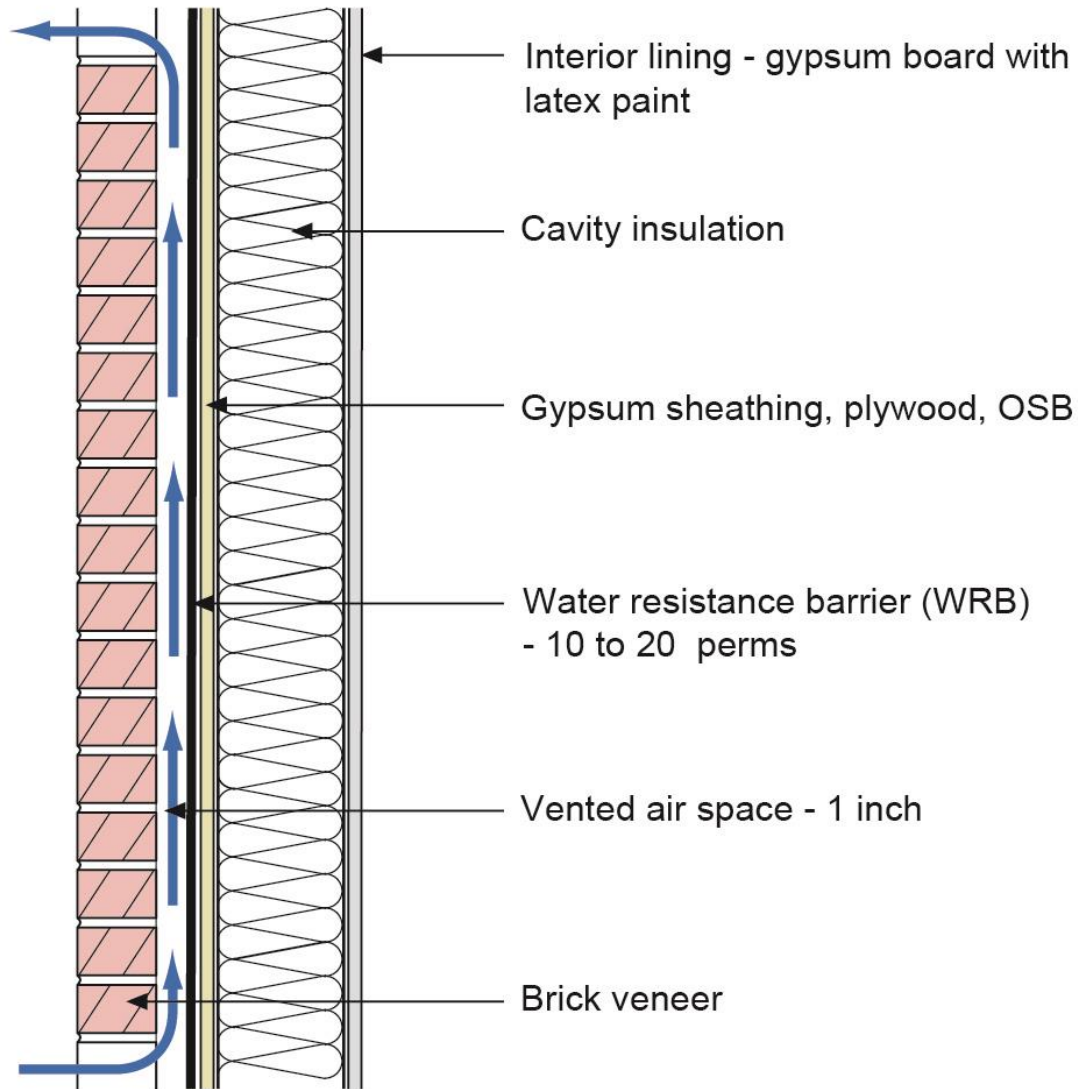



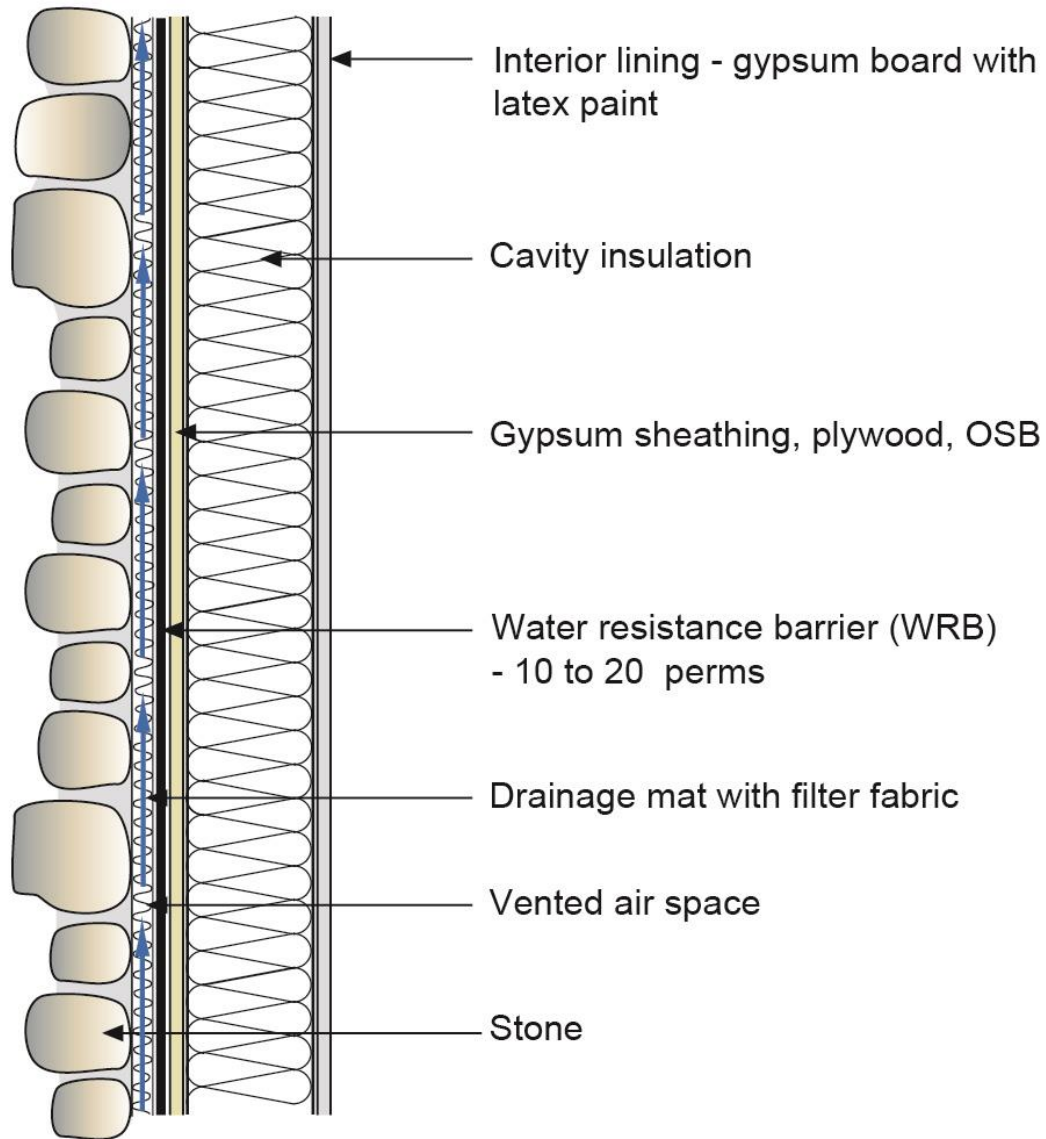

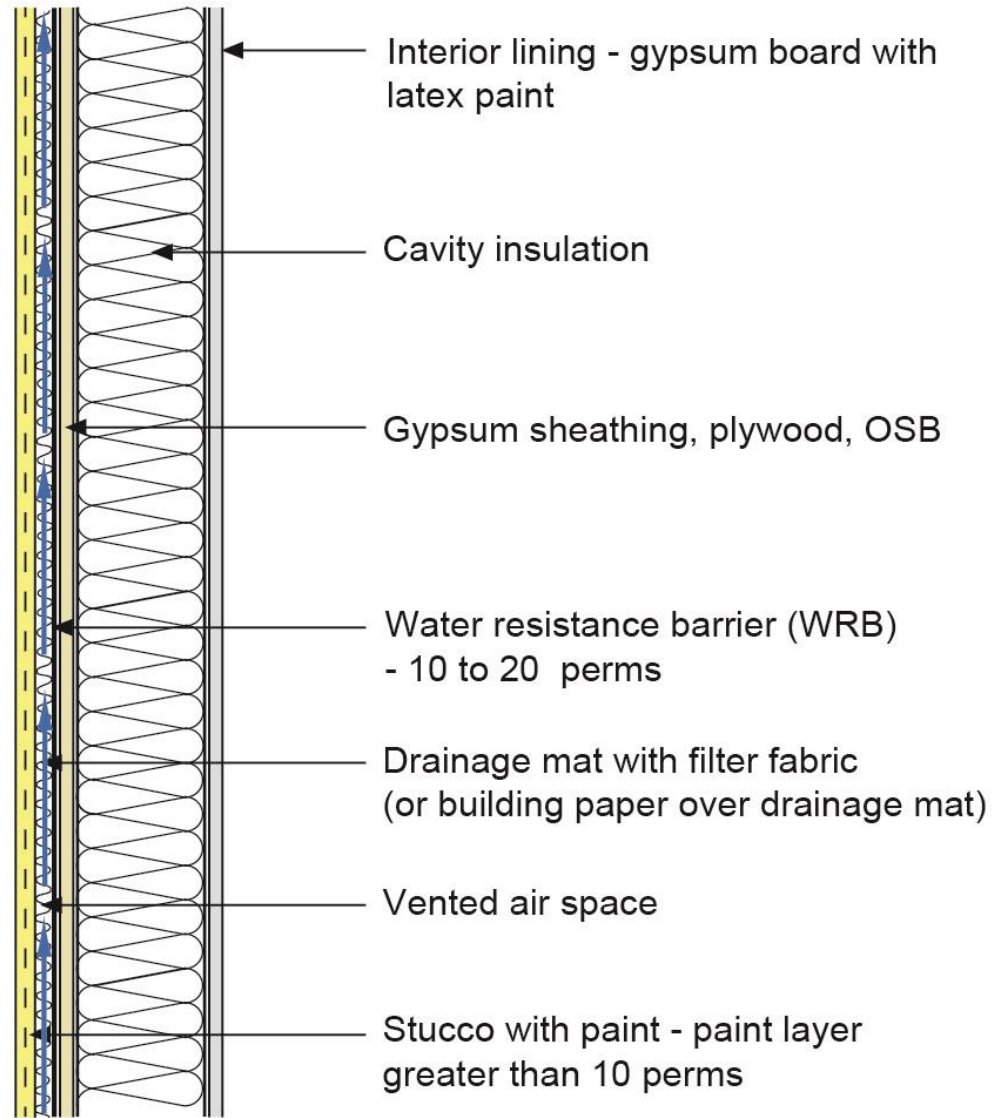

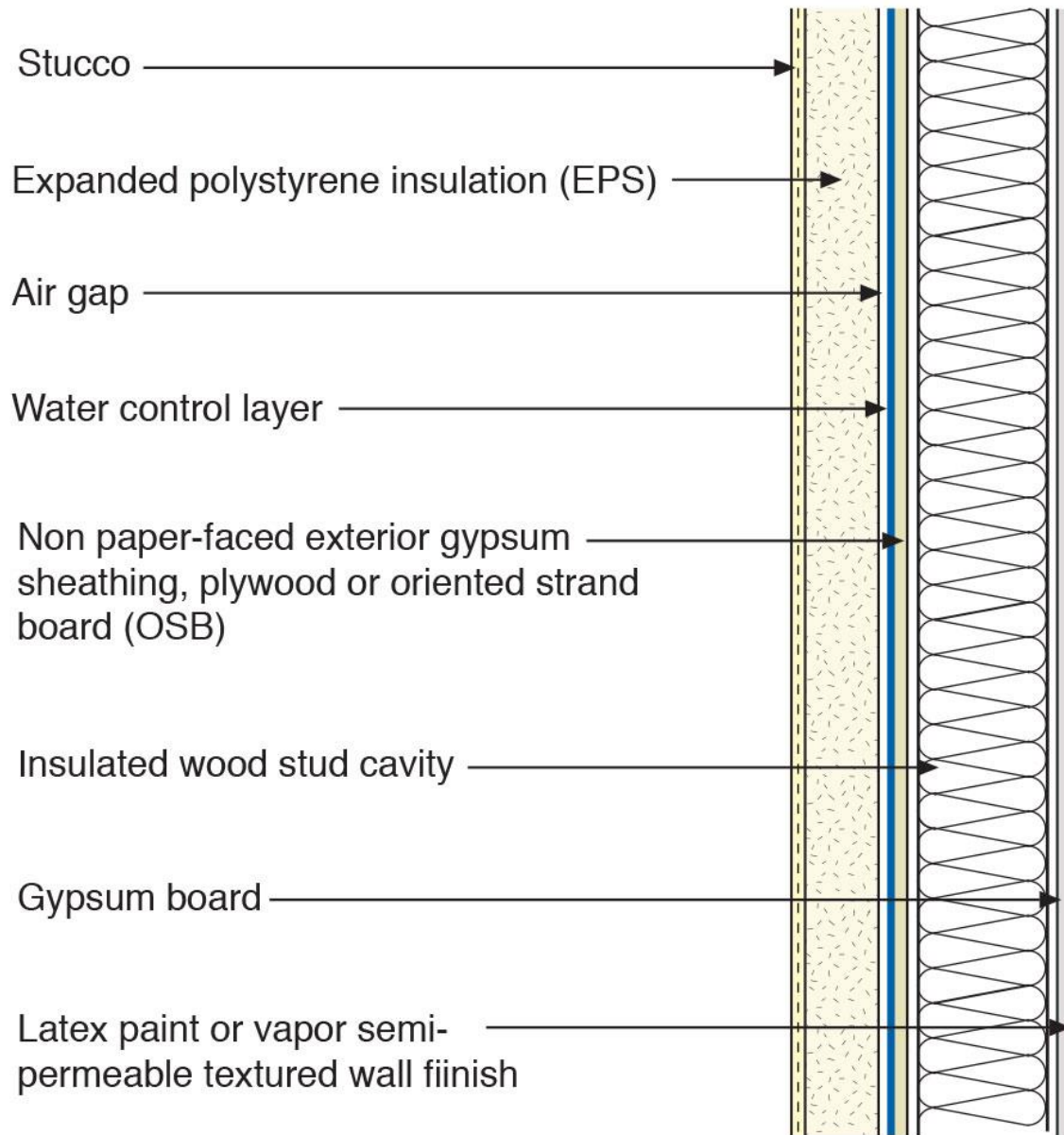

# Cladding Attachment



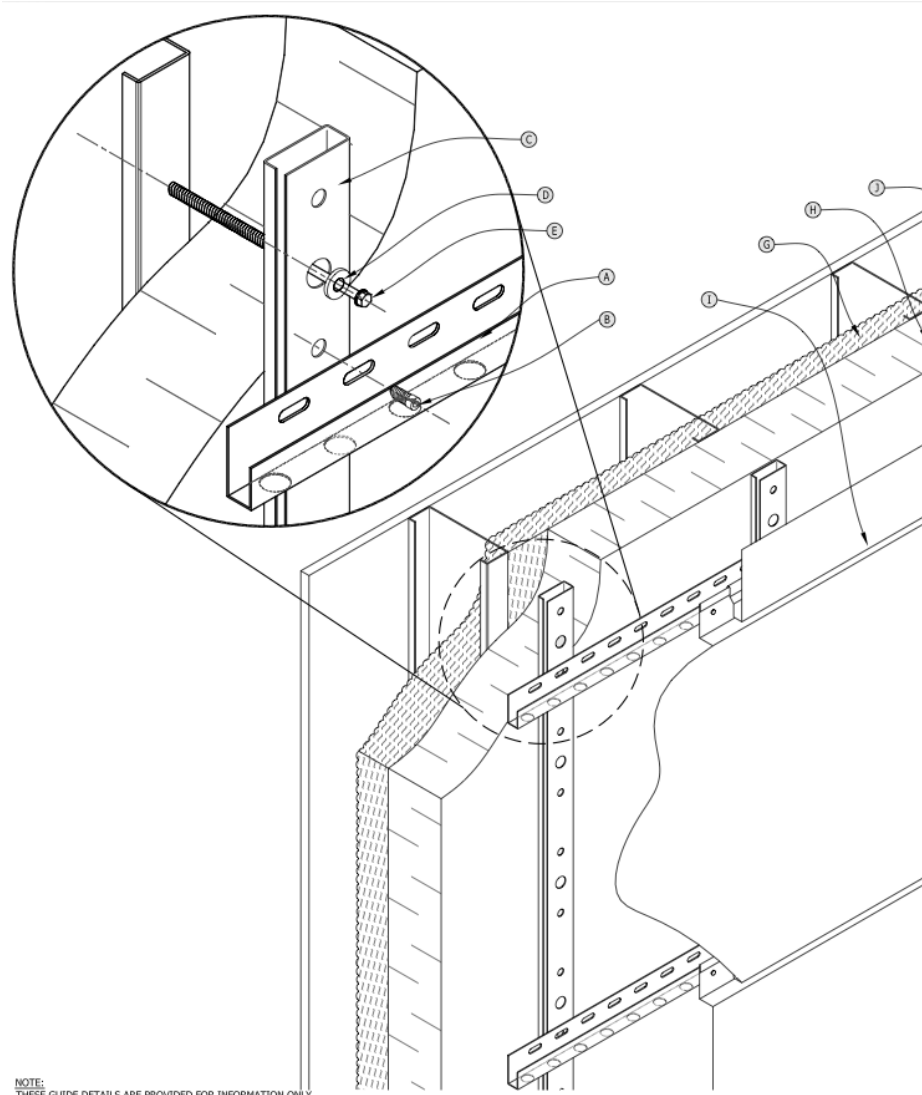

NOTE:  
THIS IS NOT A FINAL DRAWING AND IS PROVIDED FOR INFORMATION ONLY

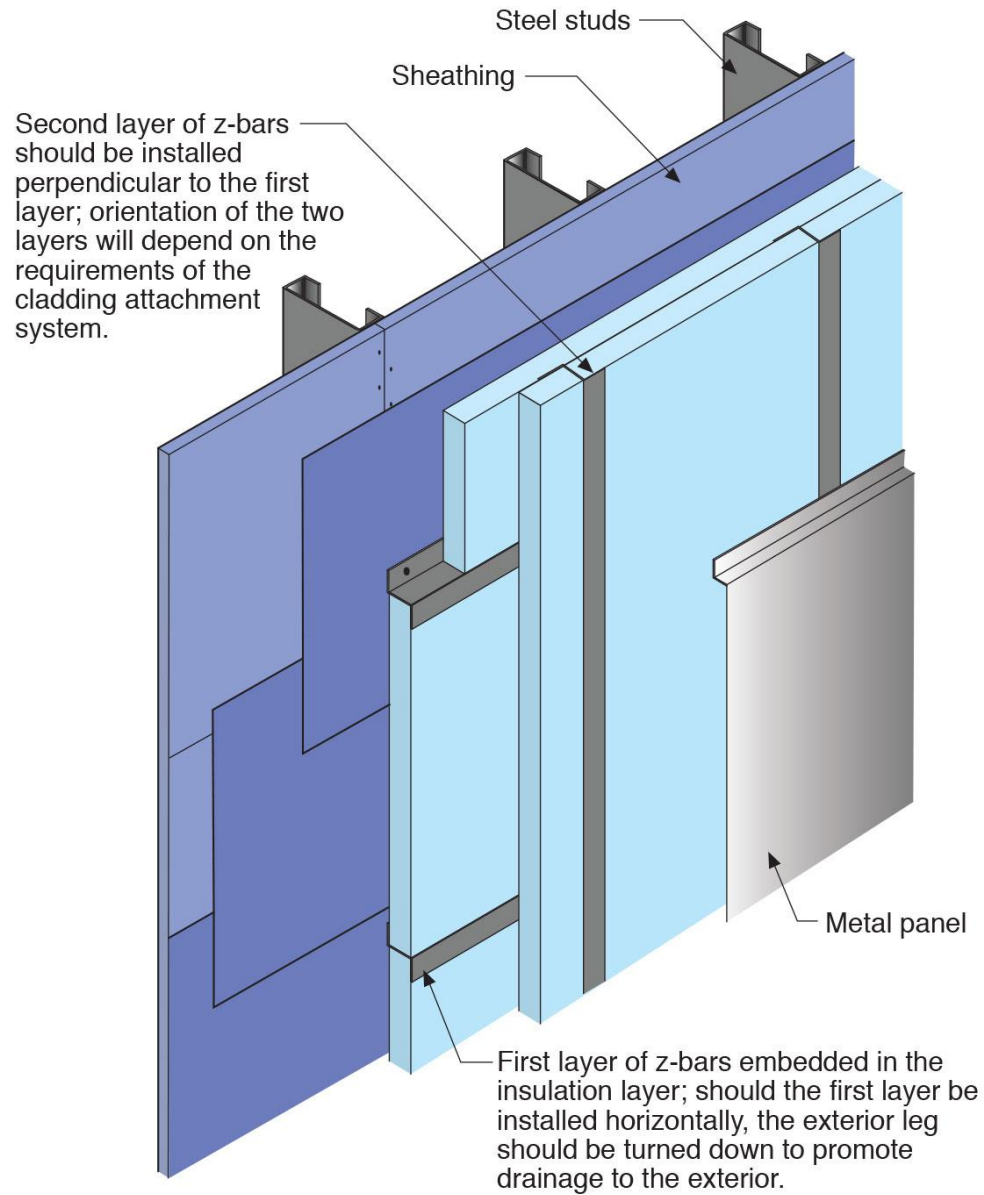

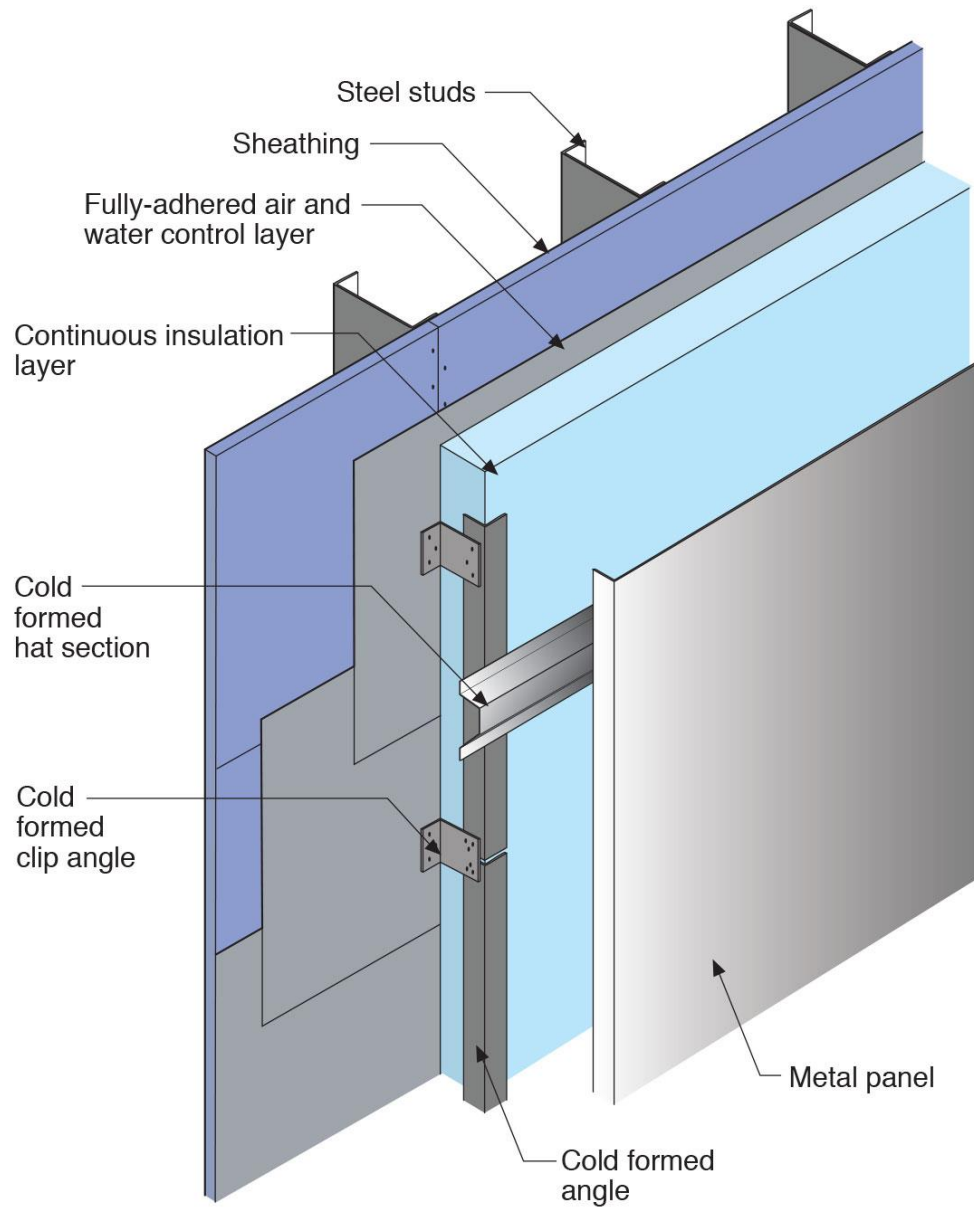





# Open Rain Screen

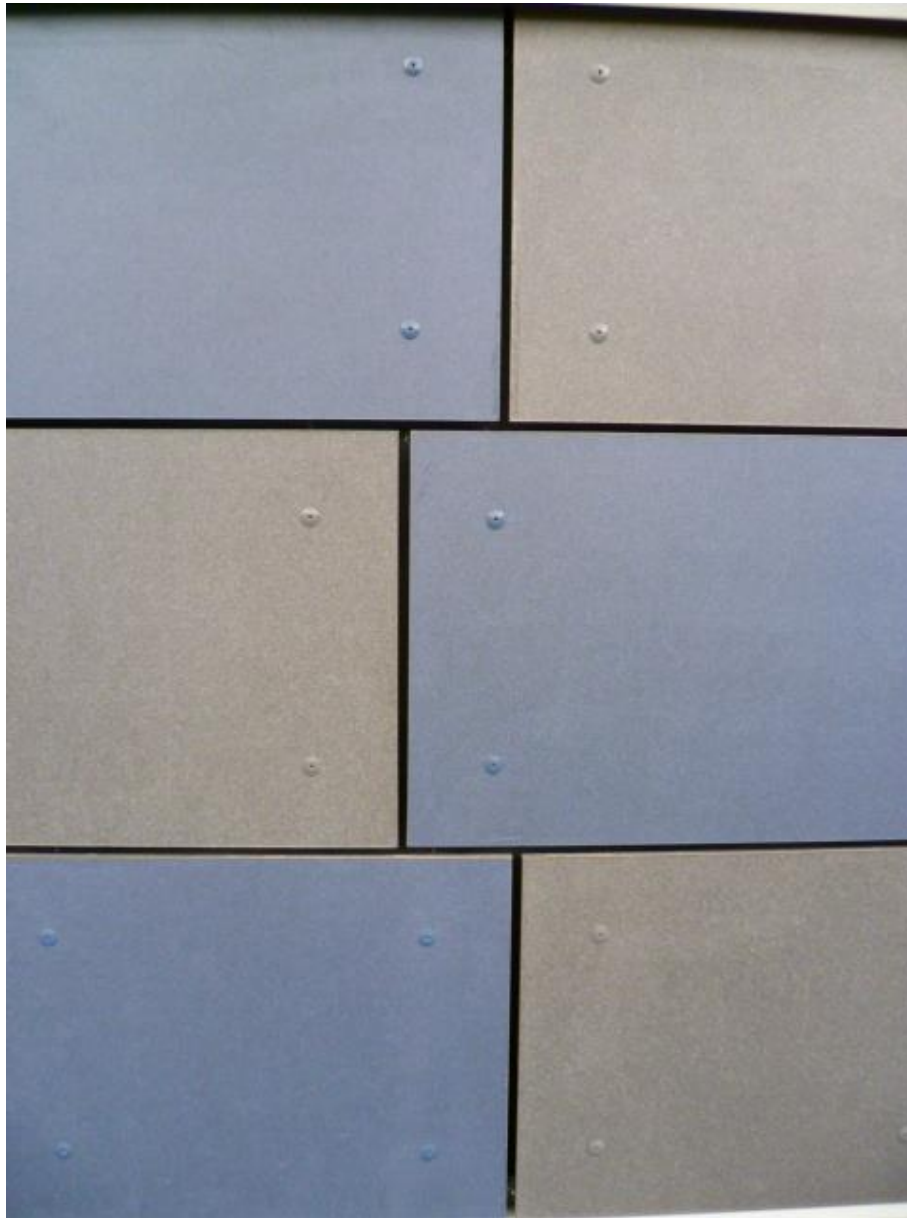











# Beer Screen?

