

Joseph Lstiburek, Ph.D., P.Eng, ASHRAE Fellow

Building Science

Adventures In Building Science

presented by www.buildingscience.com

“It isn’t what we don’t know that gives us trouble, it’s what we know that ain’t so”

Will Rogers

“There are known knowns. These are things we know. There are known unknowns. There are things that we know we don’t know. But there are also unknown unknowns. There are things we don’t know we don’t know.

Donald Rumsfeld

Faking the Physics.....

Flow Through Orifices

Turbulent Flow - “inertial effects”

Flow Through Porous Media

Laminar Flow - “viscosity effects”

Flow Through Orifices

Turbulent Flow - “inertial effects”

Flow Through Porous Media

Laminar Flow - “viscosity effects”

“true but not useful”

$$Q = A \cdot C_D \left[\frac{2}{\rho} (\Delta P) \right]^{\frac{1}{2}}$$

Bernoulli

$$Q = C_K \frac{\rho}{\mu} (\Delta P)$$

Darcy

$$Q = A \cdot C_D \left[\frac{2}{\rho} (\Delta P) \right]^{\frac{1}{2}} \quad \text{Bernoulli}$$

$$Q = C_K \frac{\rho}{\mu} (\Delta P) \quad \text{Darcy}$$

$$Q = A \cdot C (\Delta P)^{\frac{1}{2}}$$

$$Q = C (\Delta P)$$

$$Q = A \cdot C_D \left[\frac{2}{\rho} (\Delta P) \right]^{\frac{1}{2}}$$

Bernoulli

$$Q = C_K \frac{\rho}{\mu} (\Delta P)$$

Darcy

$$Q = A \cdot C (\Delta P)^{\frac{1}{2}}$$

$$Q = C (\Delta P)$$

$$Q = A \cdot C (\Delta P)^n$$

Kronval “an engineer”

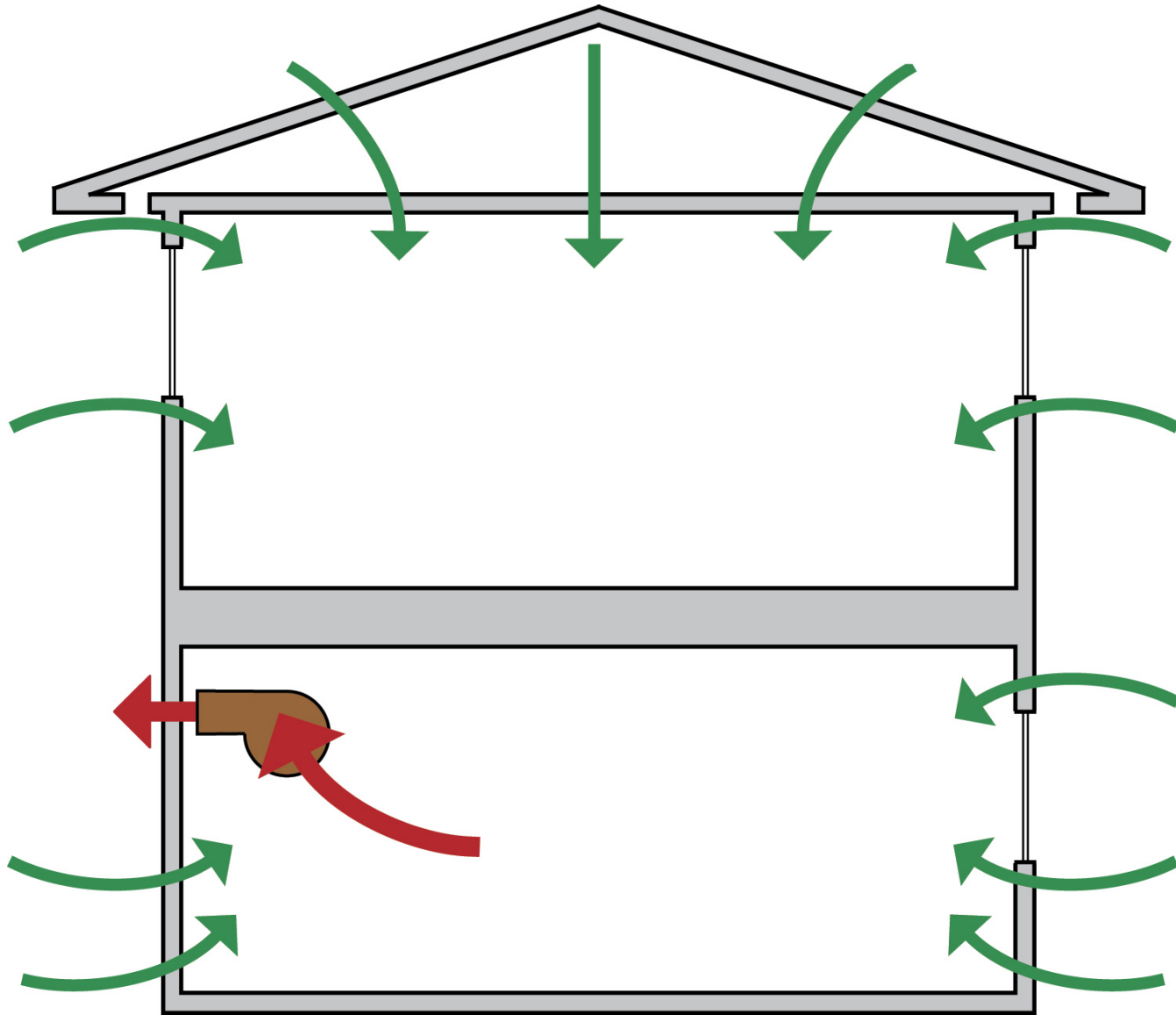

$$ELA \approx C \times \frac{\text{Rate of flow}}{\sqrt{\text{Pressure difference}}}$$

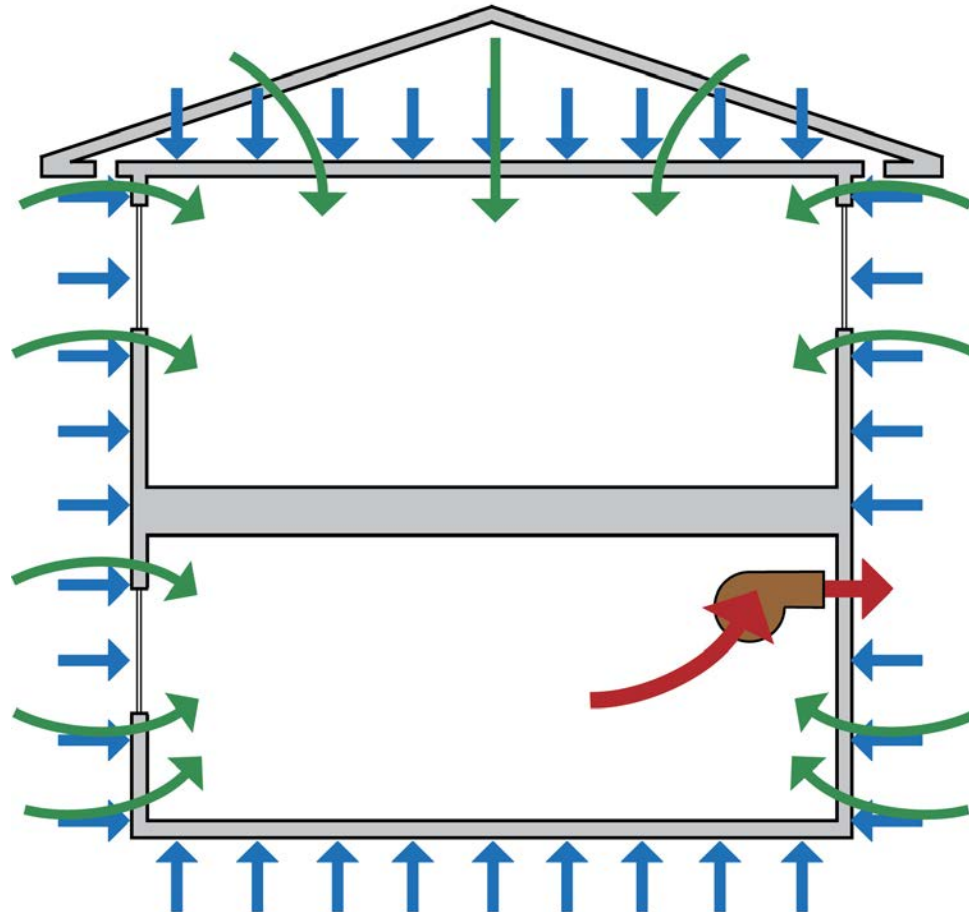

$$(\text{Meters})^2 \approx \frac{1}{780} \times \frac{\text{Litres per second}}{\sqrt{\text{Pascals}}}$$

Possible air flows around sill of a wood-framed house modelled as a resistance network

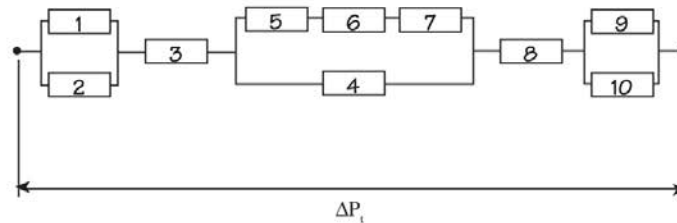
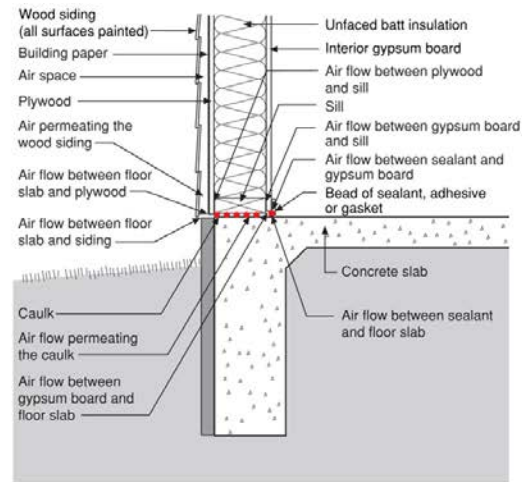

1. Air permeating the wood-panel cladding
2. Air flow between floor slab and panel
3. Air flow between floor slab and wind protection
4. Air permeating the caulking
5. Air flow between wind protection and sill
6. Air flow between insulation material and sill
7. Air flow between inner lining and sill
8. Air flow between inner lining and floor slab
9. Air flow between fillet and inner lining
10. Air flow between fillet and floor slab

Figure 2.10
Resistance Network
 (from Kronvall, 1980)

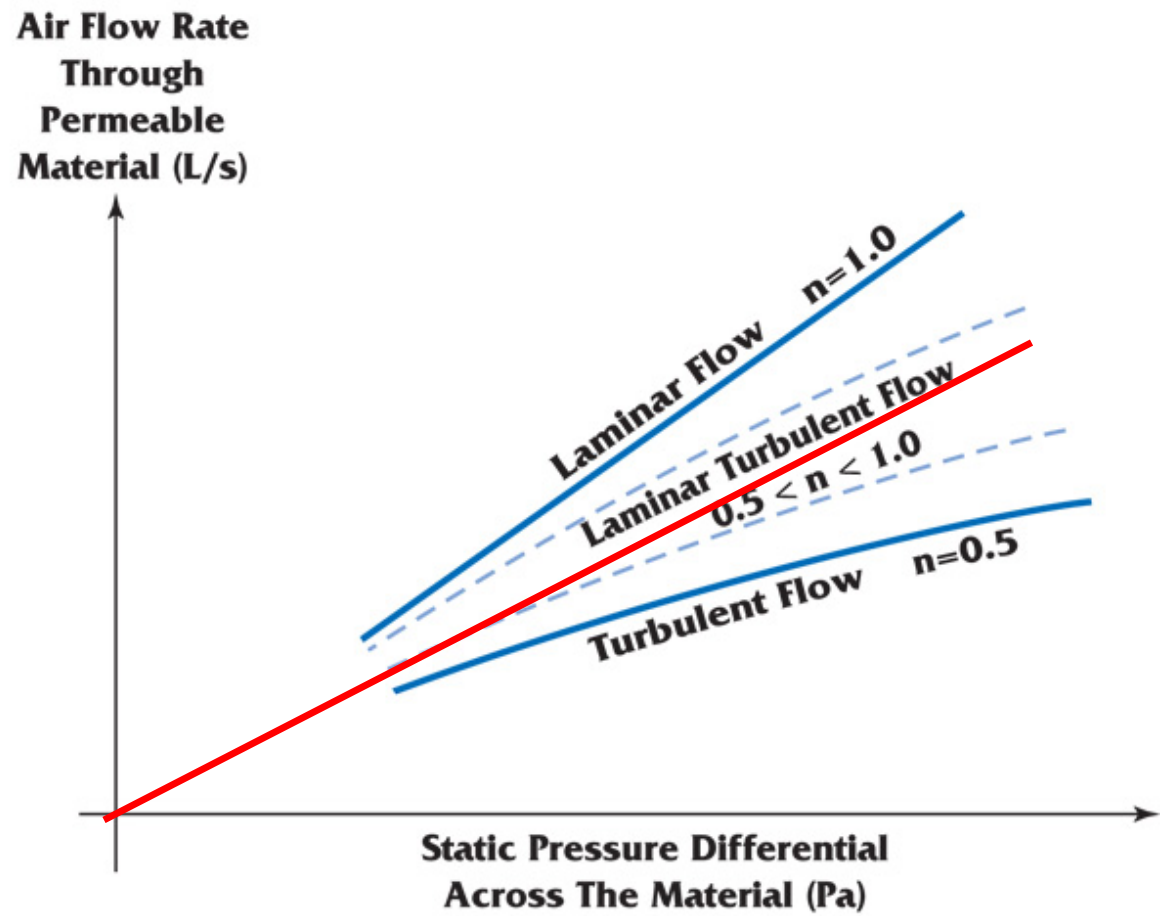

Figure 2.5

Modes of Air Flow

(from Bumbaru, Jutras and Patenaude, 1988)

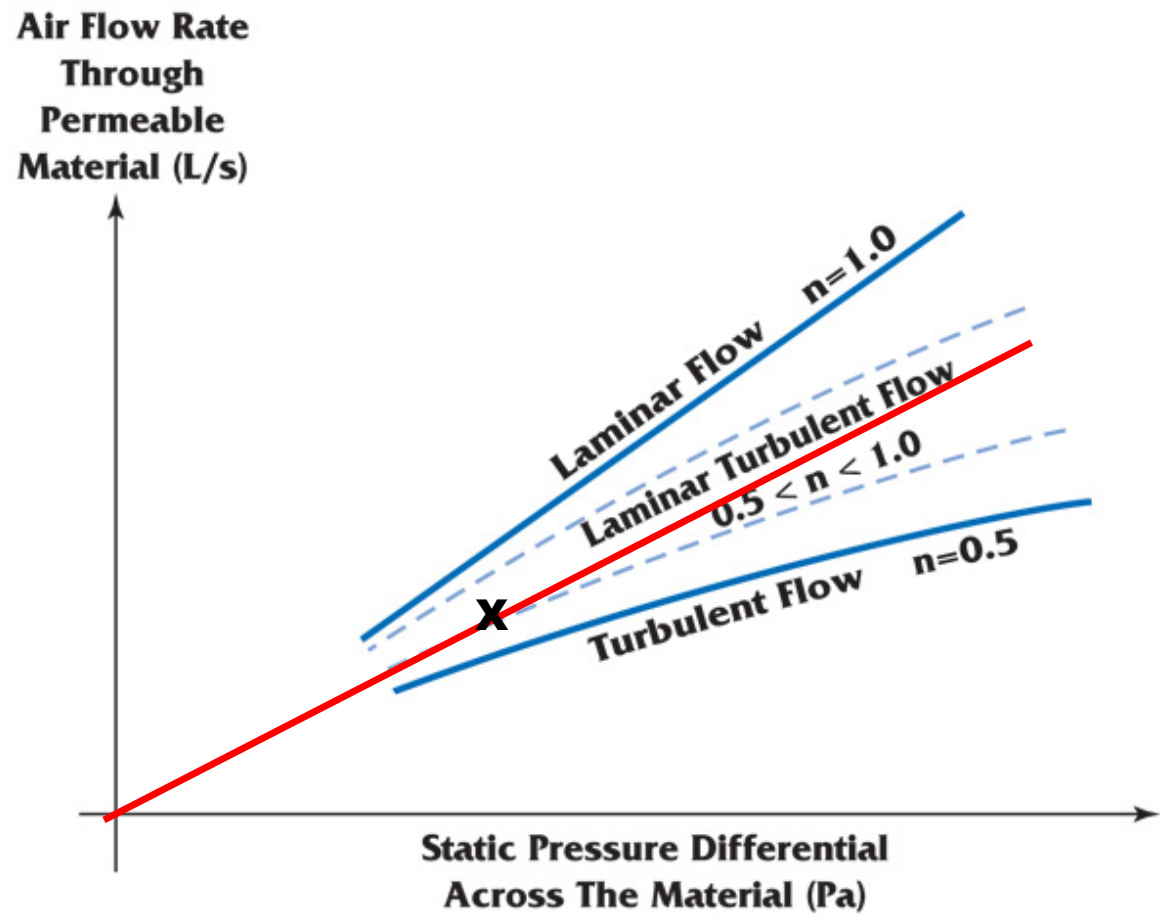

Figure 2.5
Modes of Air Flow
 (from Bumbaru, Jutras and Patenaude, 1988)

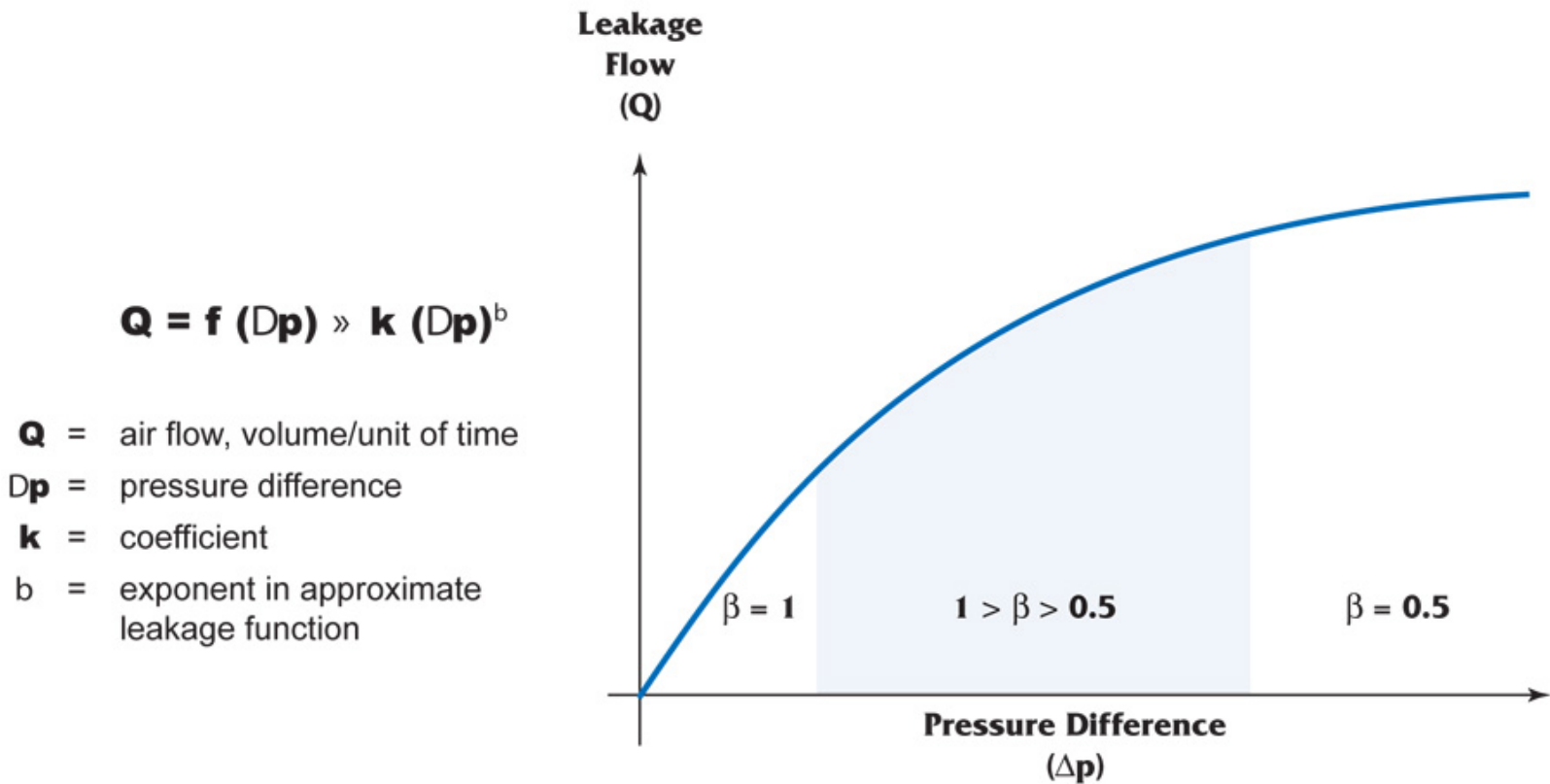

Figure 2.6
Characteristic Curve of Leakage Flow as a Function of Pressure Difference
 (from Nylund, 1980)

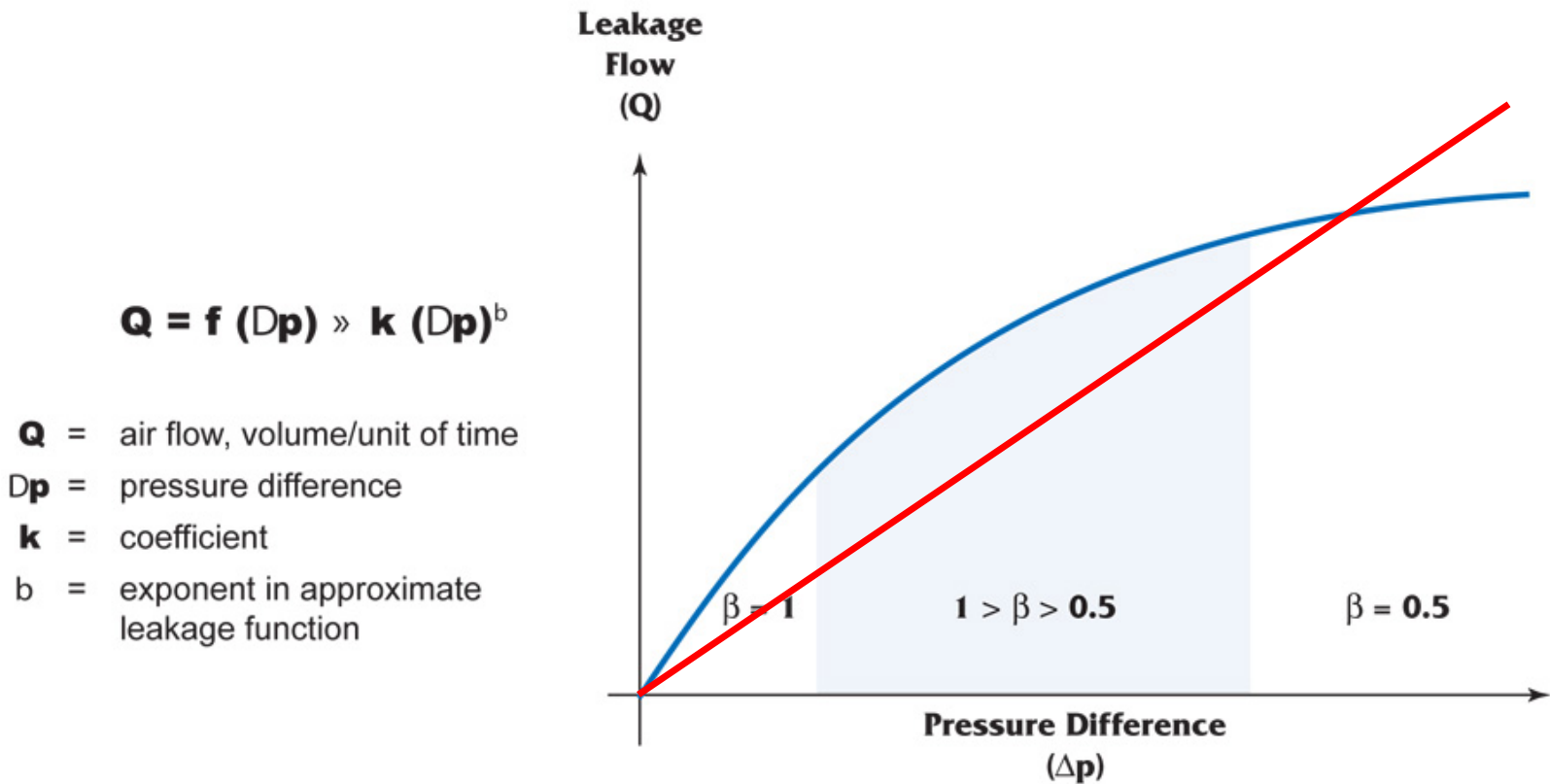

Figure 2.6
Characteristic Curve of Leakage Flow as a Function of Pressure Difference
 (from Nylund, 1980)

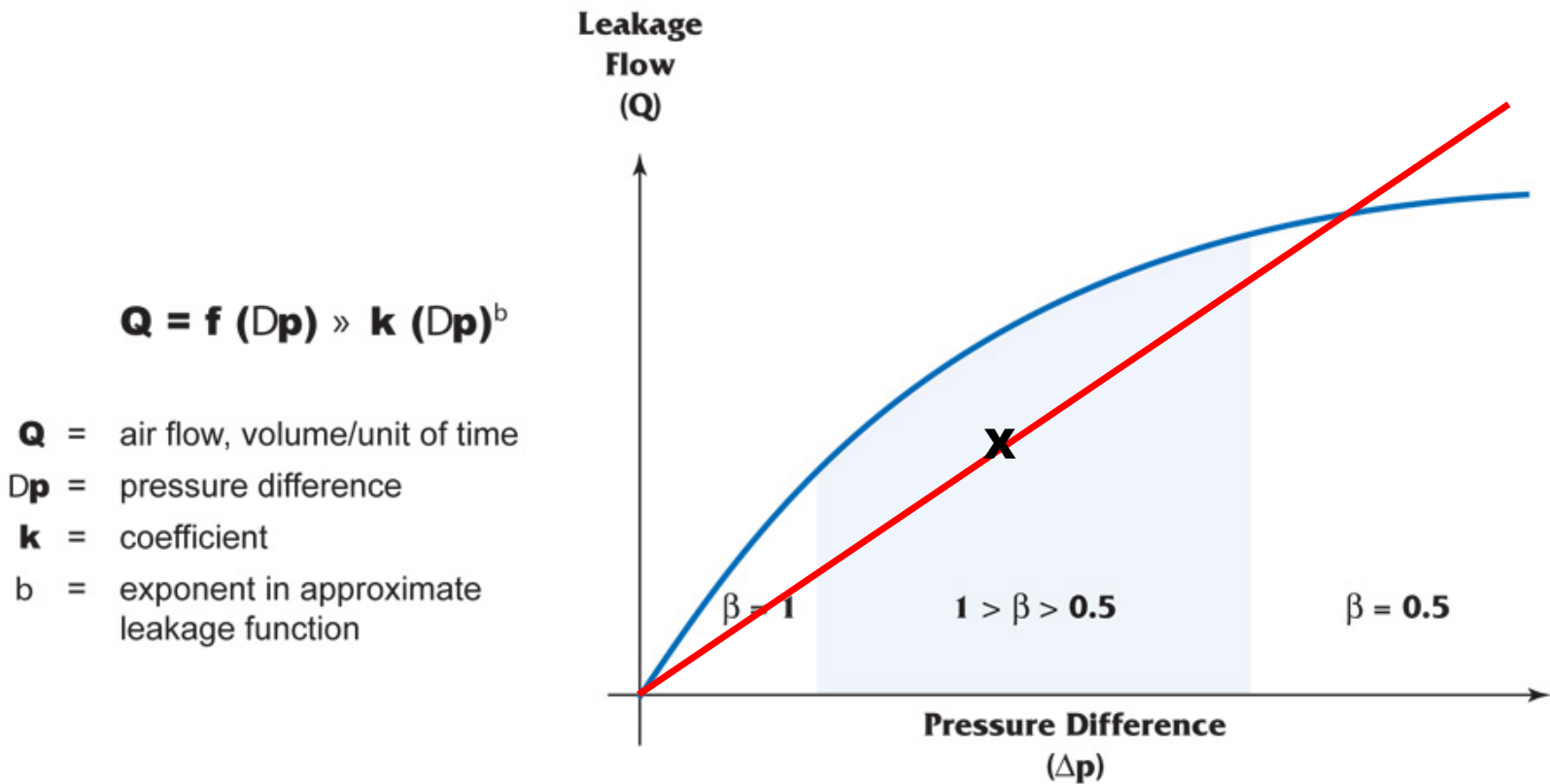
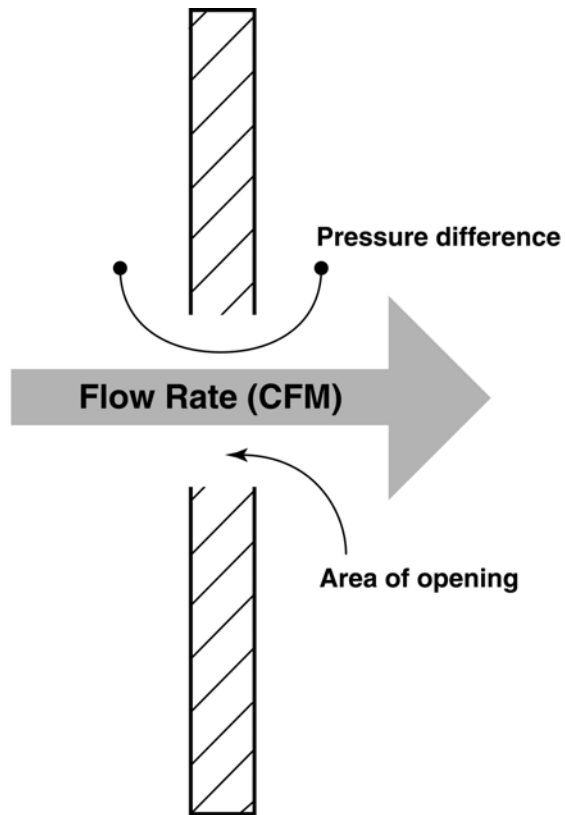

Figure 2.6
Characteristic Curve of Leakage Flow as a Function of Pressure Difference
 (from Nylund, 1980)



Air Flow

- Air flow depends on size of hole
- Air flow depends on pressure difference
$$\text{Flow} \cong \text{Area} \times \sqrt{\Delta P} \times \text{Coefficient}$$
- Air flows from higher pressure to lower pressure

The Cult of The Blower Door



Blower Door Can't Get You The True ACH On A Short Term Basis – Hour, Day, Week

Don't Know Where The Holes Are

Don't Know The Type of Holes

Don't Know The Pressure Across The Holes

Why Do We Suck and Not Blow?

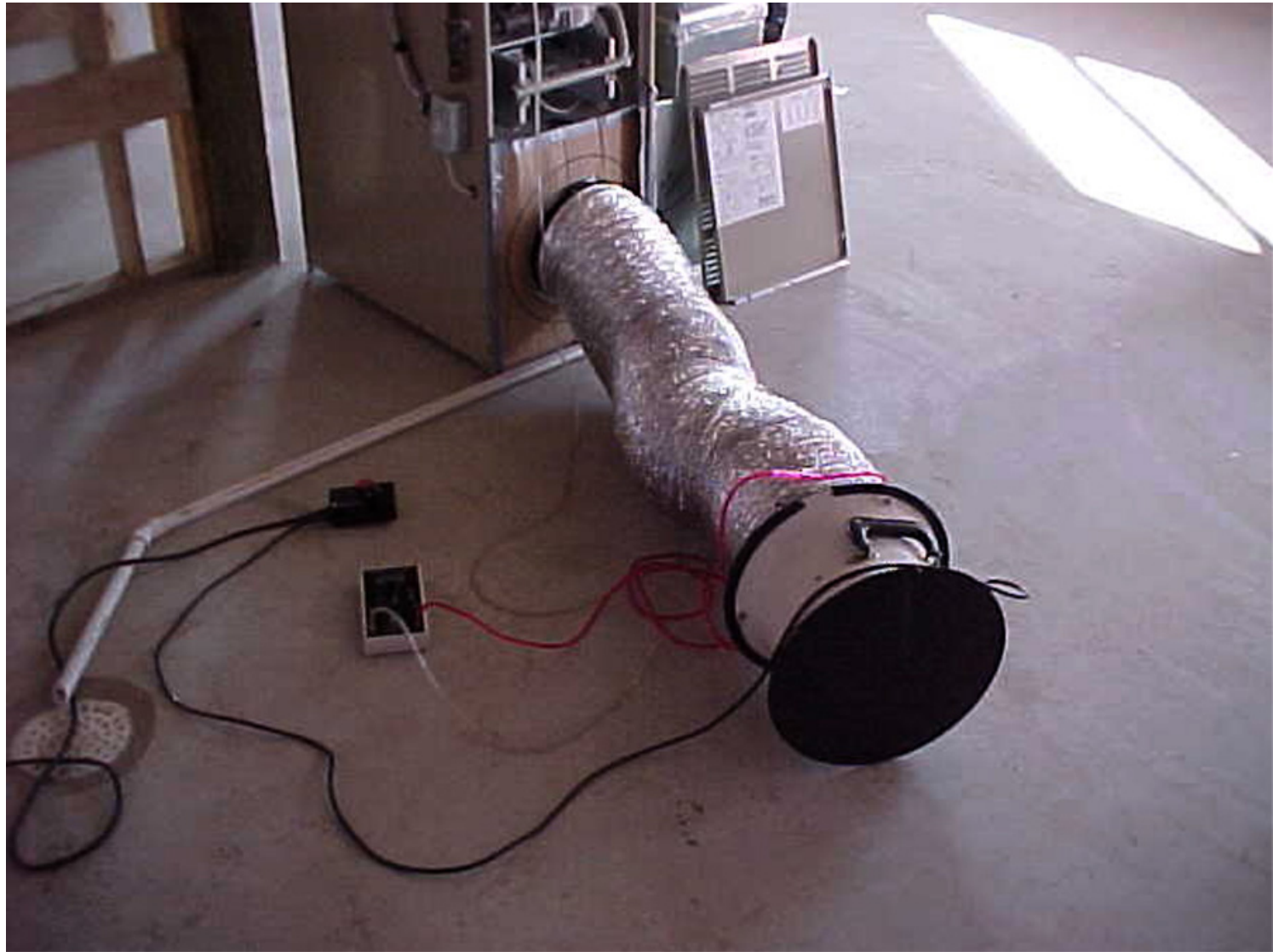

Figure 2.11
**Three Dimensional Multi-Layer
Multi-Cell Analogue**

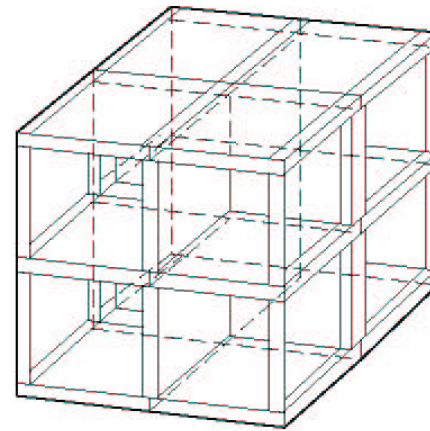

Figure 2.12
**Three Dimensional Multi-Layer
Multi-Cell Non-Contiguous
Analogue**

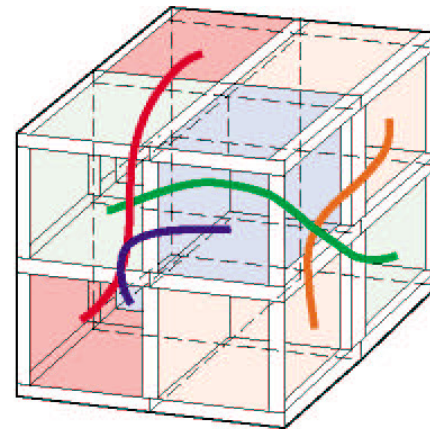
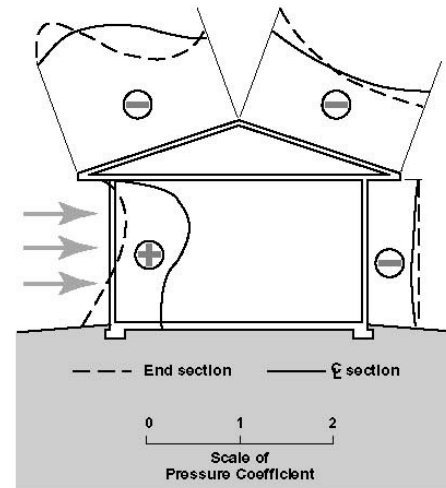
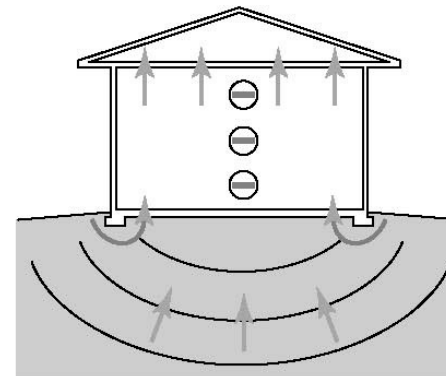

Figure 3.1
Exterior Air Pressure Field
(from Hutcheon & Handegord, 1983)



Distribution of pressures (+) and
suctions (-) on a house with a
low-sloped roof with wind
perpendicular to eave

Figure 3.2
**Exterior Air Pressure Field
Extending Below Grade**



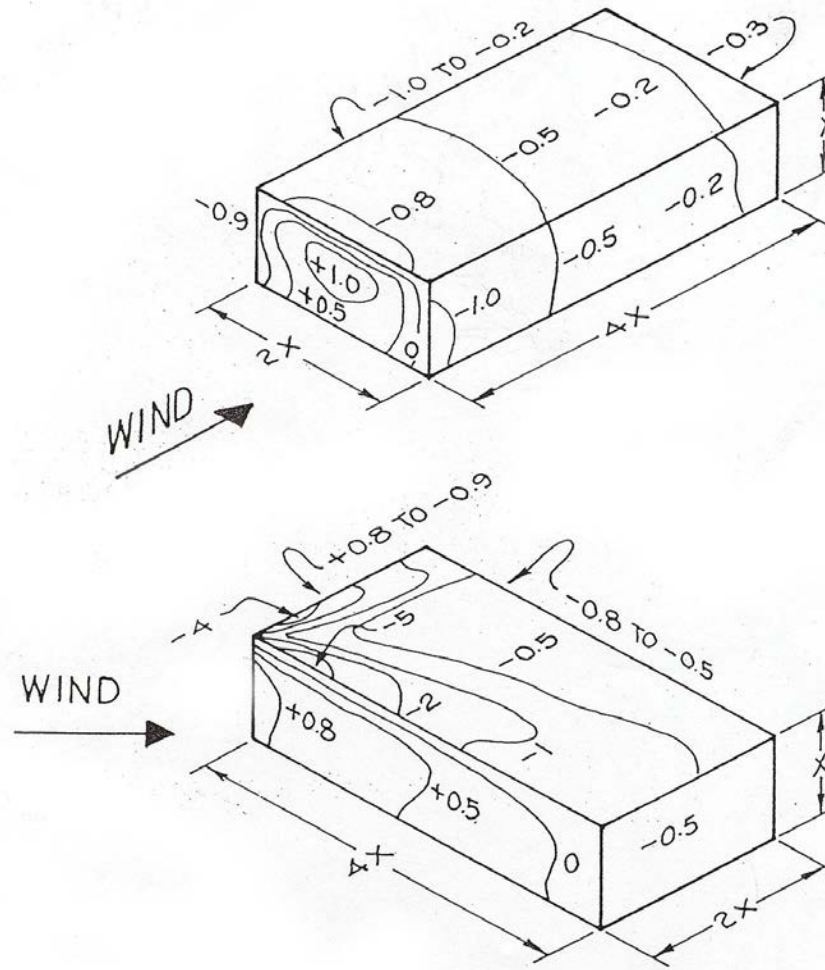

Pressure coefficients on walls and roof of rectangular buildings without parapets.

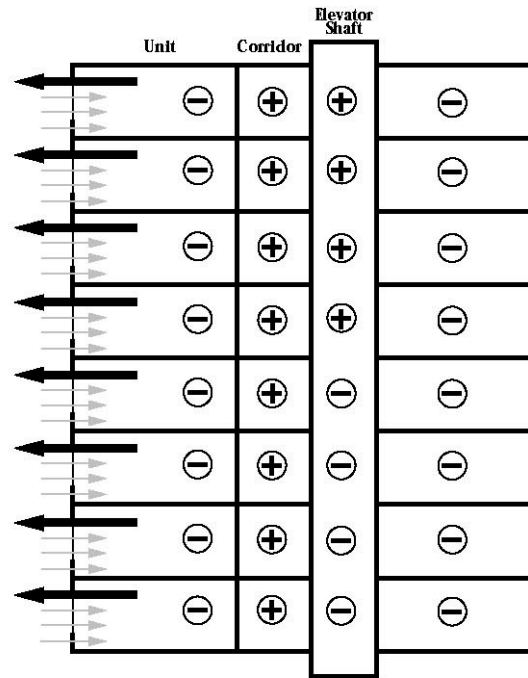

Figure 3.3
Interior Air Pressure Field

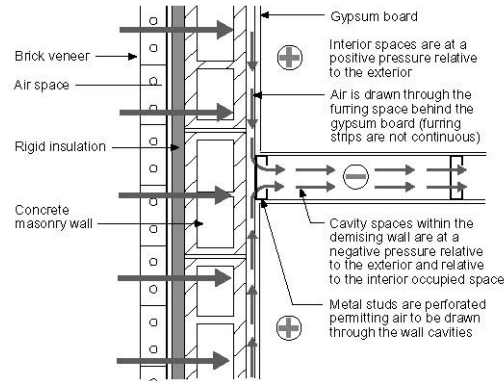

Figure 3.4
Interstitial Air Pressure Field

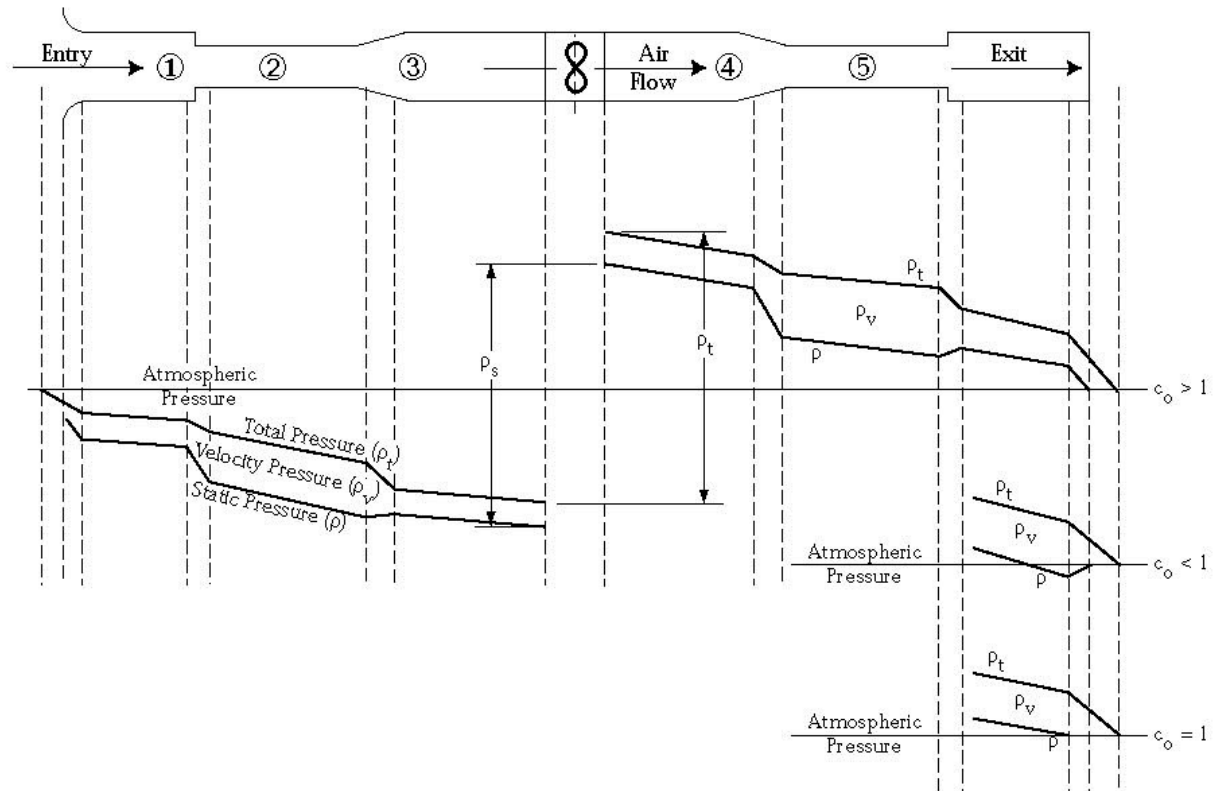

Figure 3.5
Air Conveyance System Air Pressure Field
 (from Sauer & Howell, 1990)

People

Pollutant (hot, wet, UV, ozone)

Path

Pressure











Supply air into occupied zone returns to AHU by passing through deliberately porous dropped ceiling or through return grilles installed in dropped ceiling

Air handling unit extracts air from dropped ceiling, conditions it and injects it into the occupied zones via supply ductwork

Dropped ceiling depressurized by air handling units extracting air from dropped ceiling

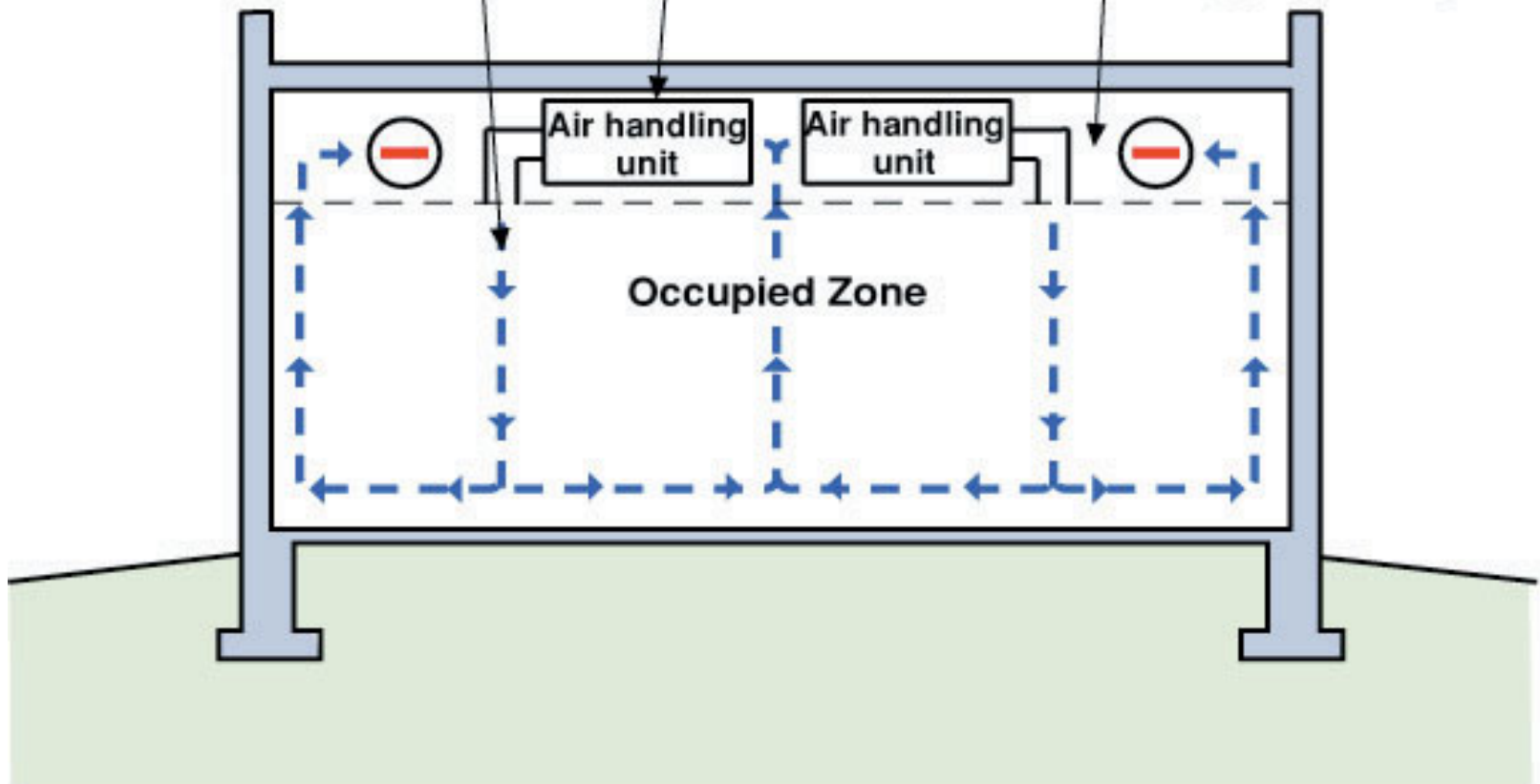

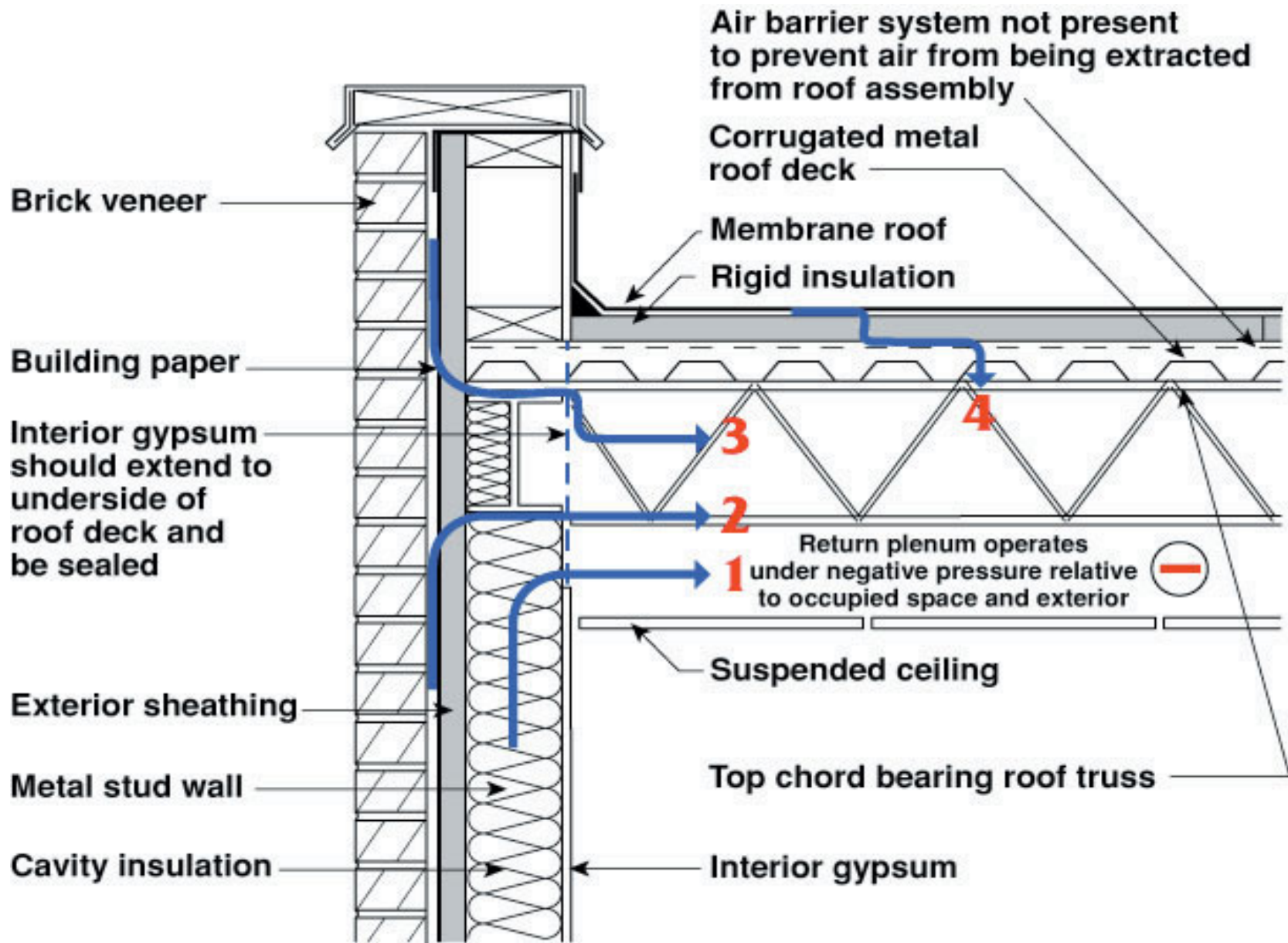

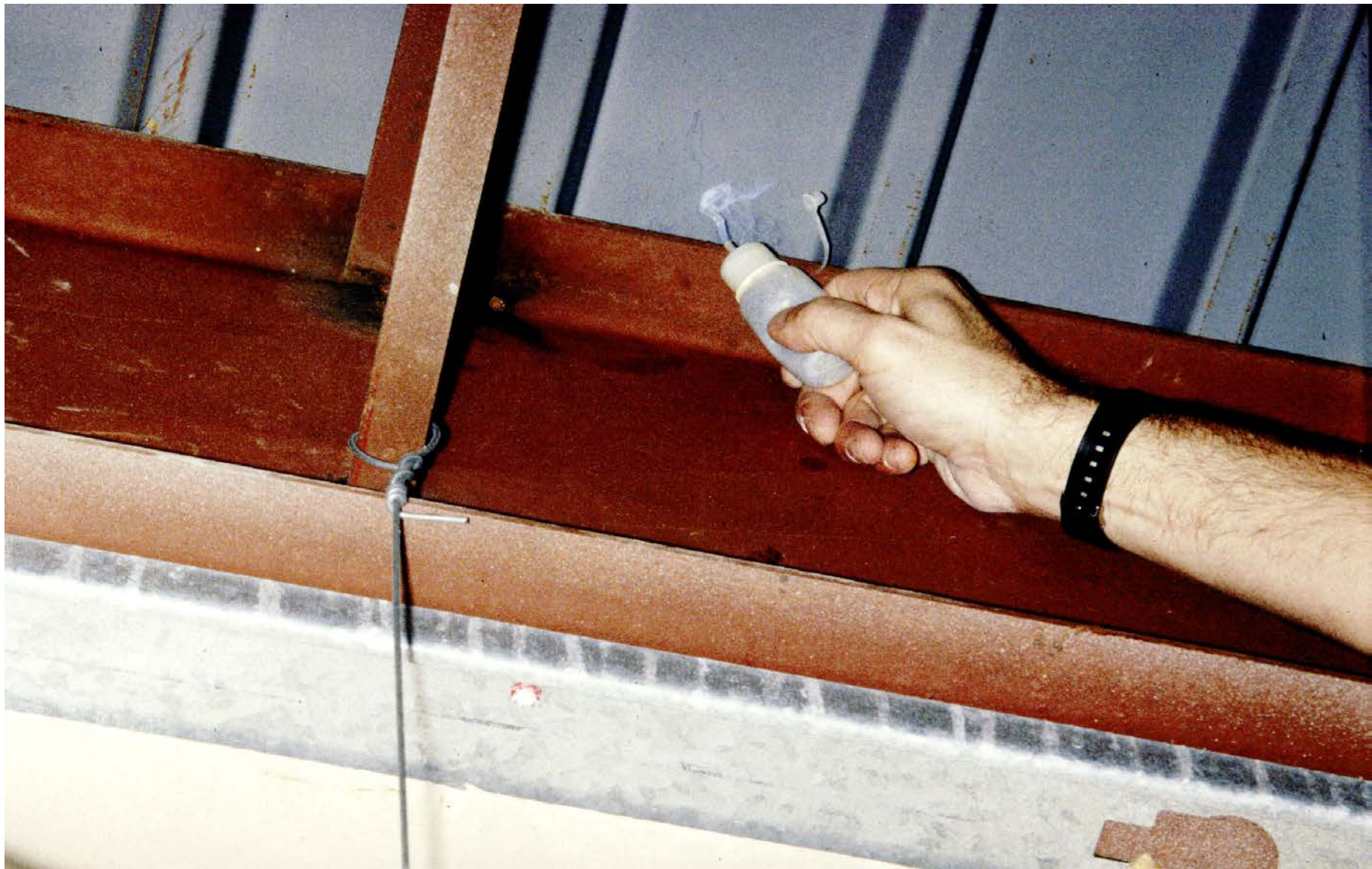





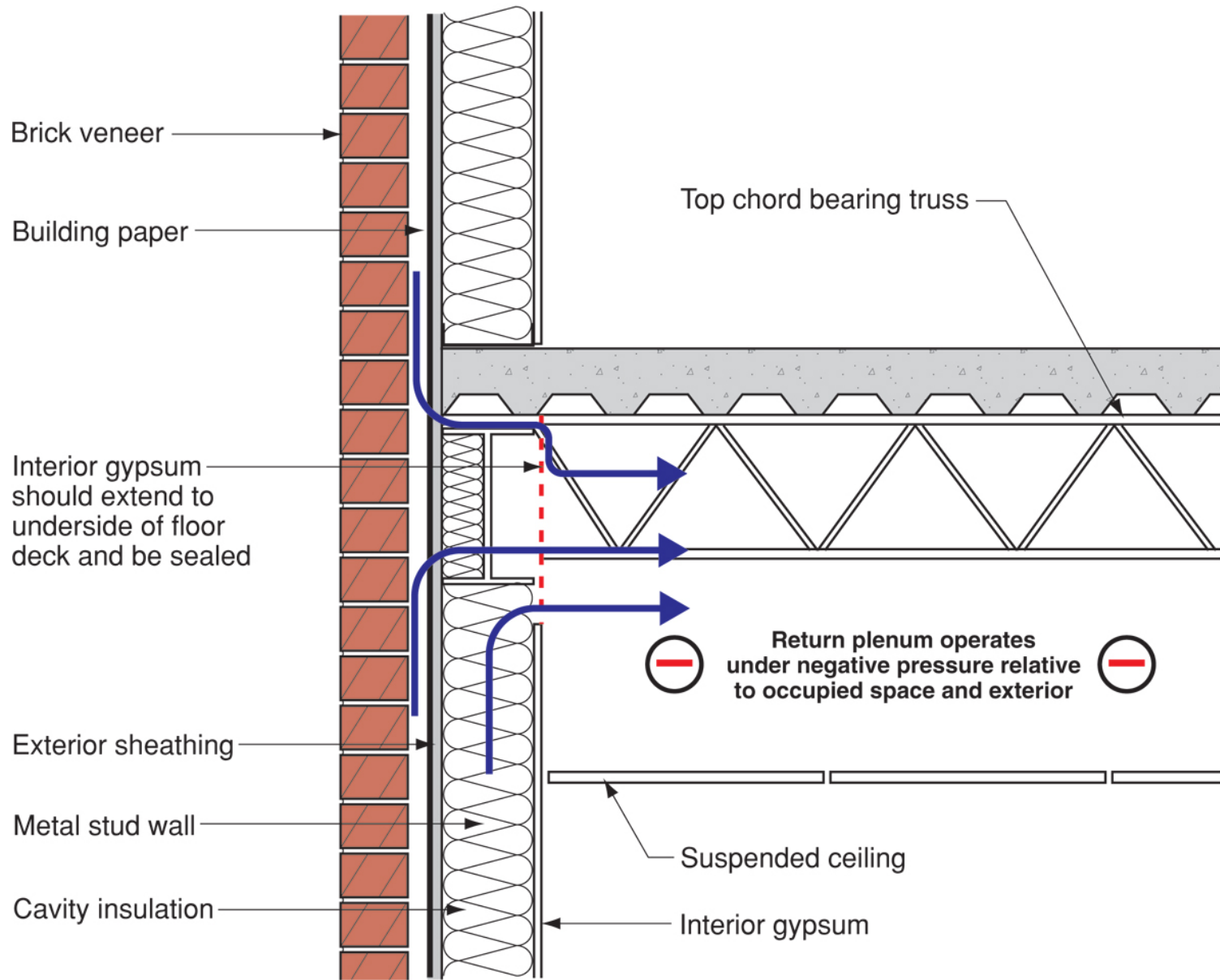















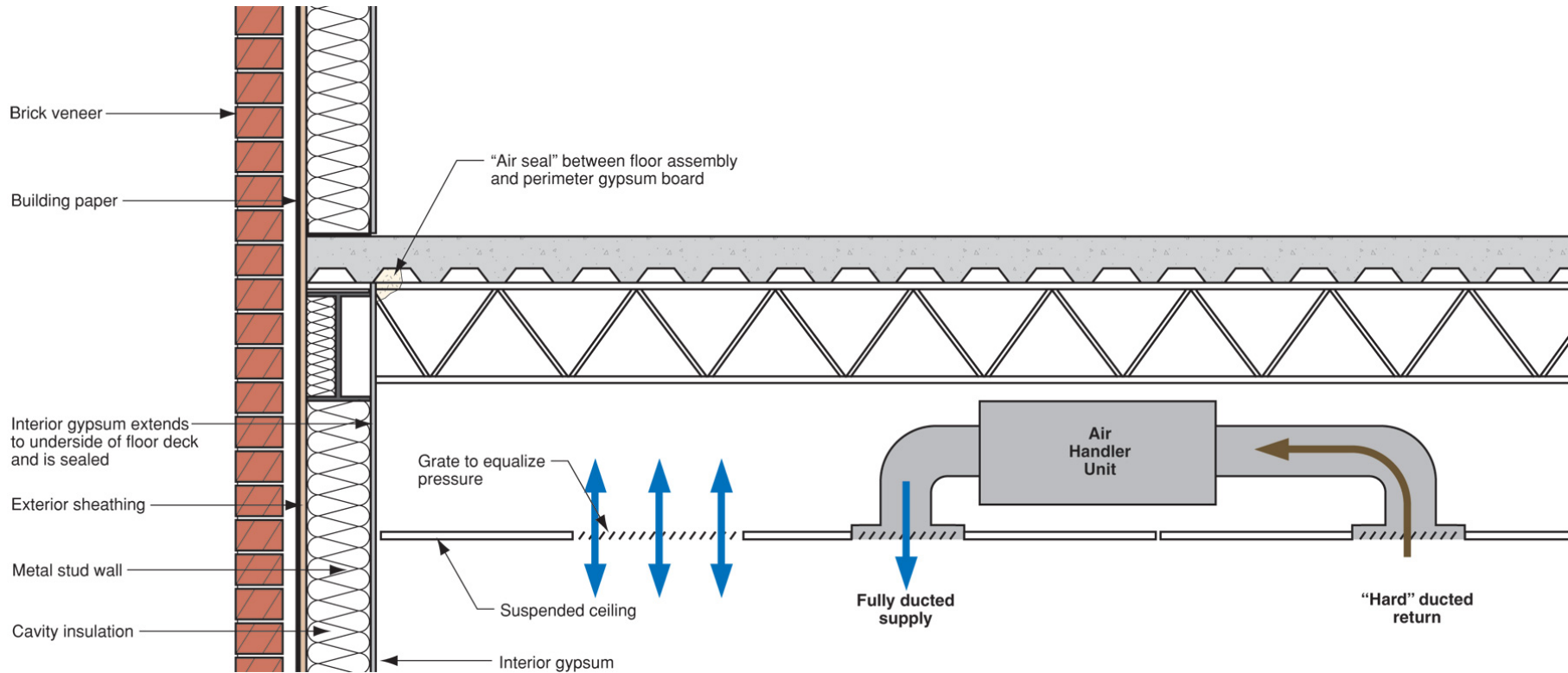













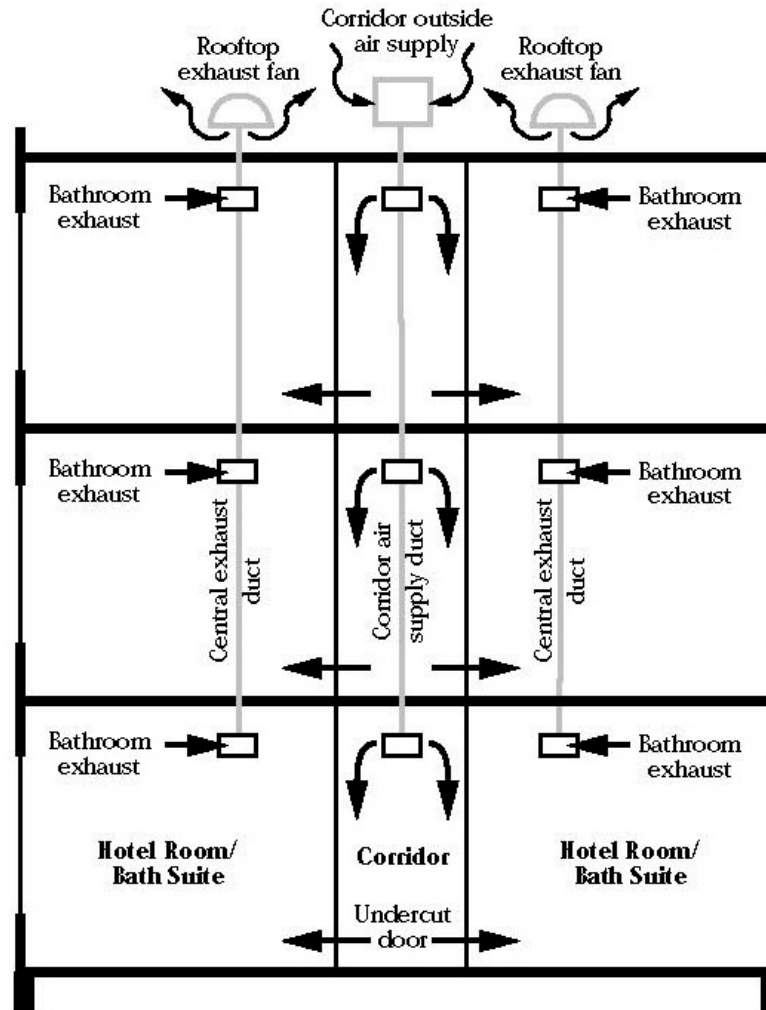

Figure 3.8

Hotel HVAC System

- Air exhausted from bathrooms via central rooftop exhaust fans
- Air supplied from corridors via undercut doors





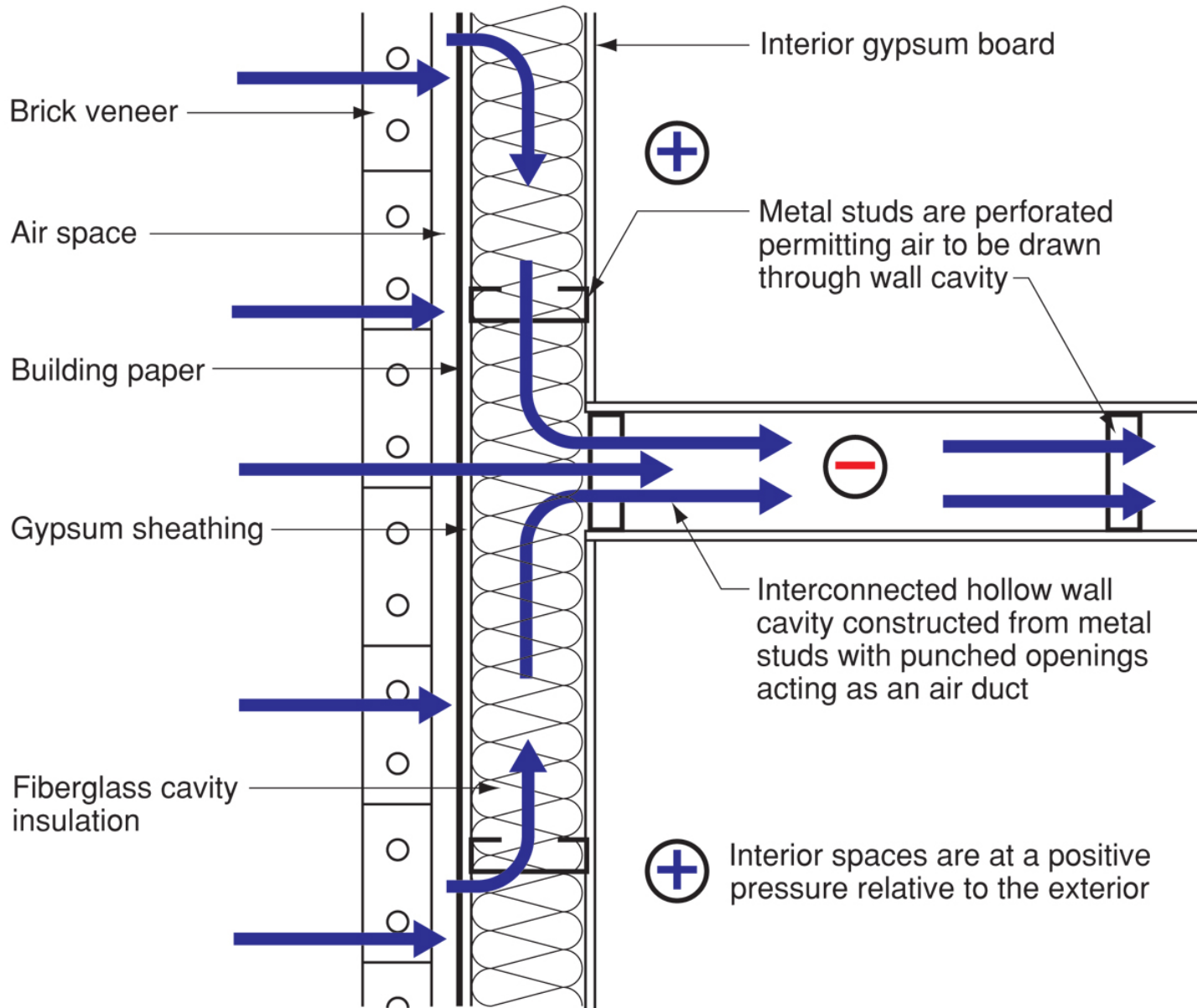

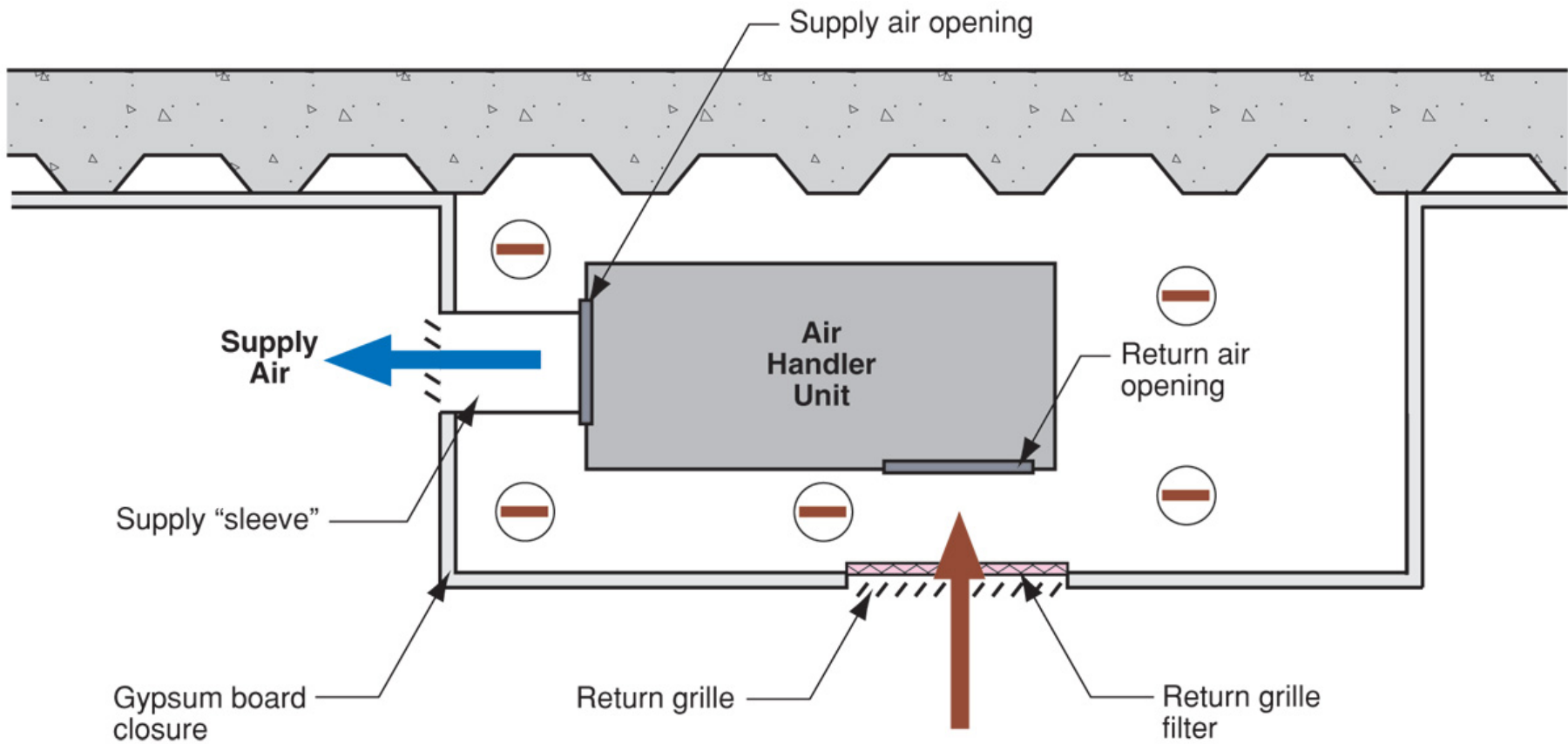

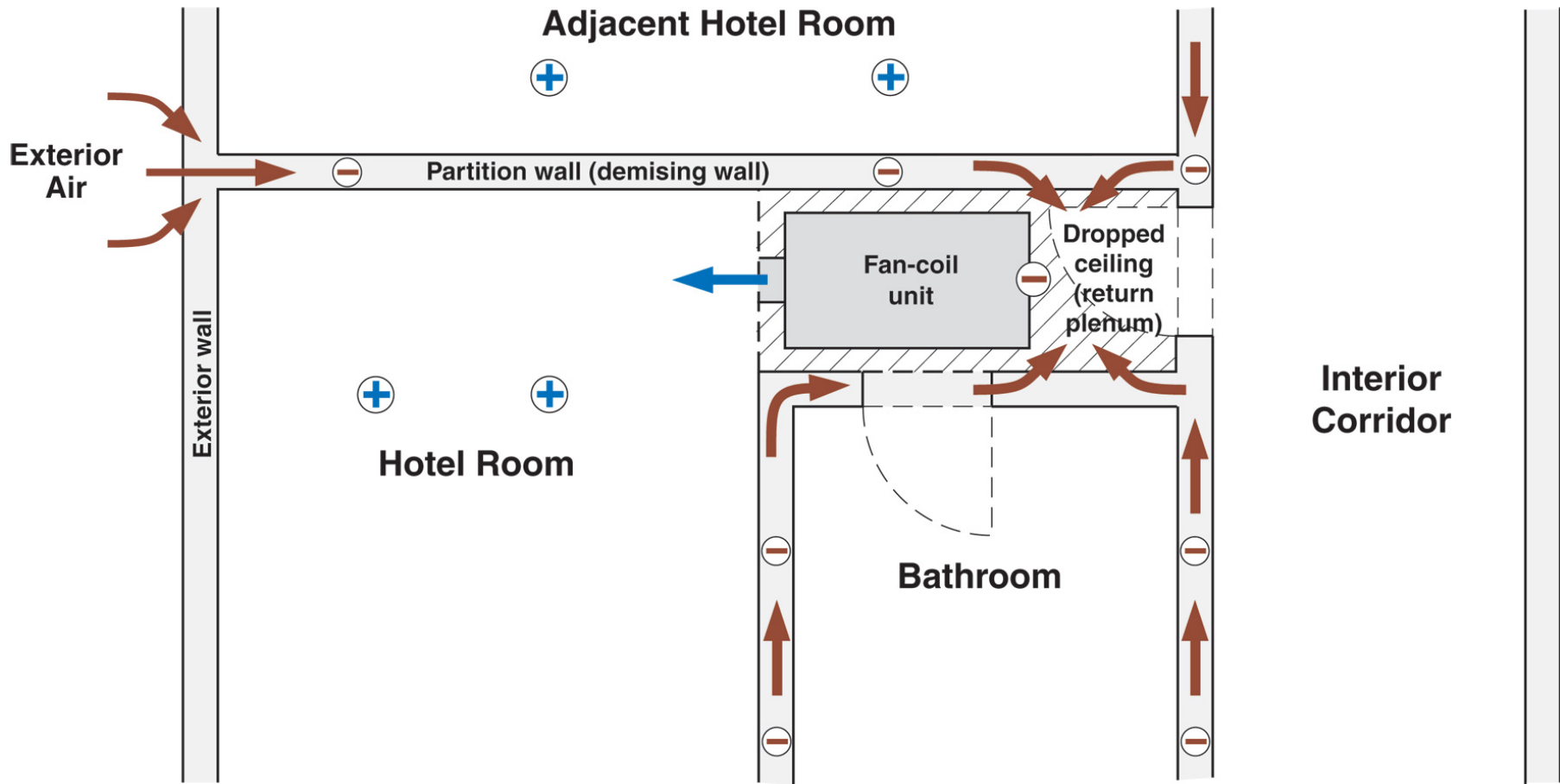

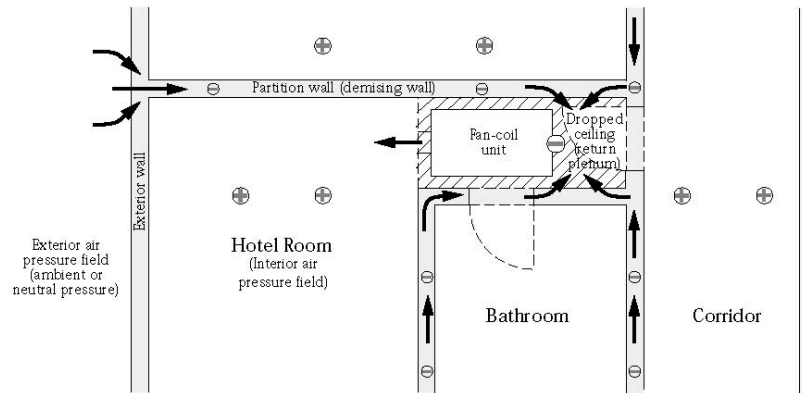

Figure 3.10
Pressure Field Due to Fan-Coil Unit
Plan View

- Room is at positive air pressure relative to exterior-driven air from corridor and air supplied to room from fan-coil unit pulling air from exterior through the demising wall
- Fan-coil unit depressurizes dropped ceiling assembly due to return plenum design
- Demising wall cavity pulled negative due to connection to dropped ceiling return plenum

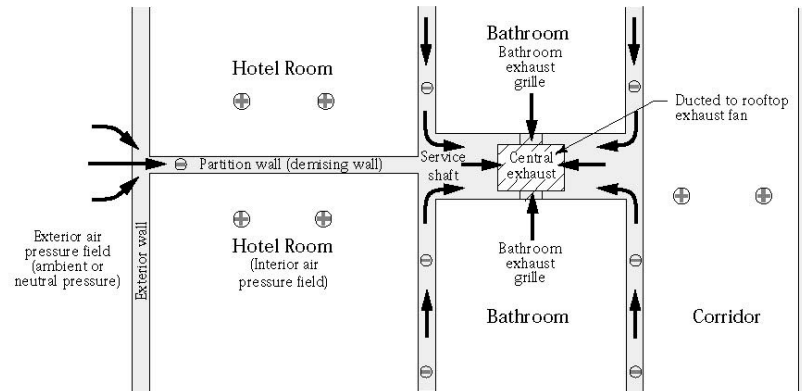

Figure 3.11
Pressure Field Due to Central Exhaust
Plan View

- Leakage of central exhaust duct pulls air out of service shaft depressurizing shaft and demising walls





















Lapse Rate

U.S. Standard Atmosphere (1976)

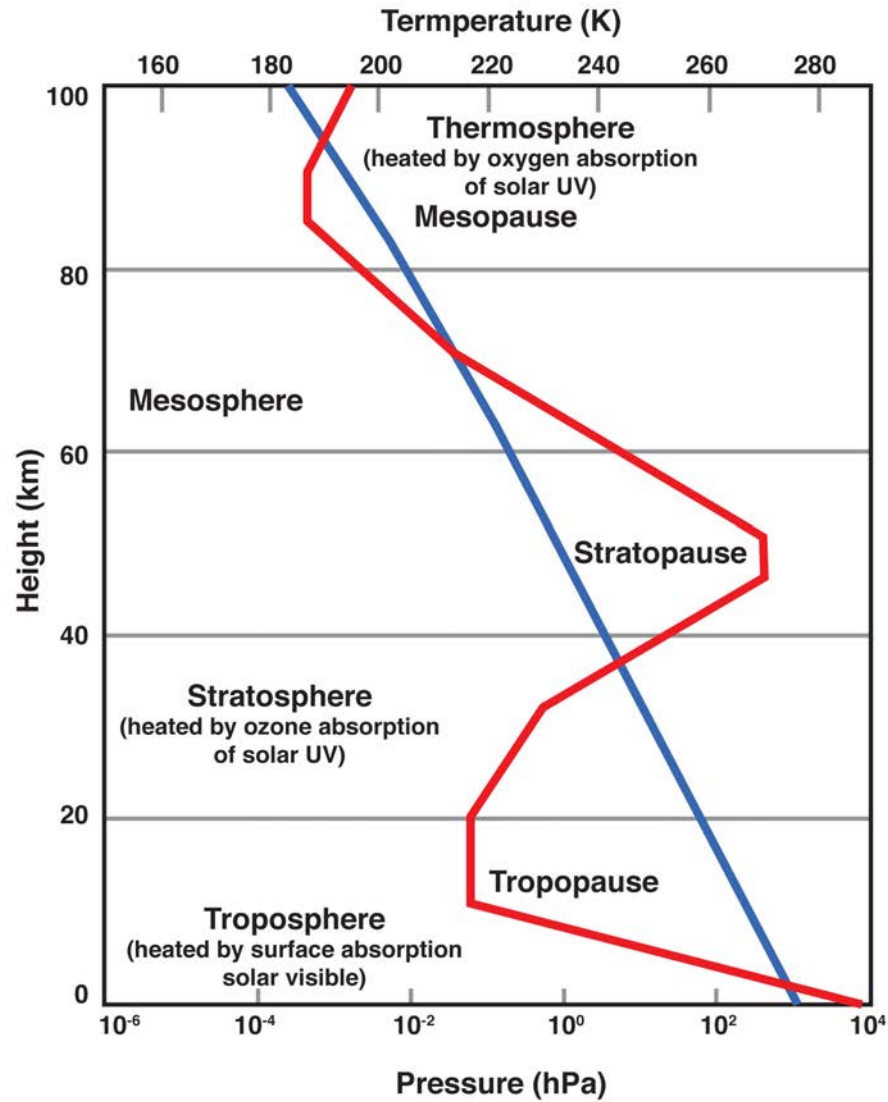

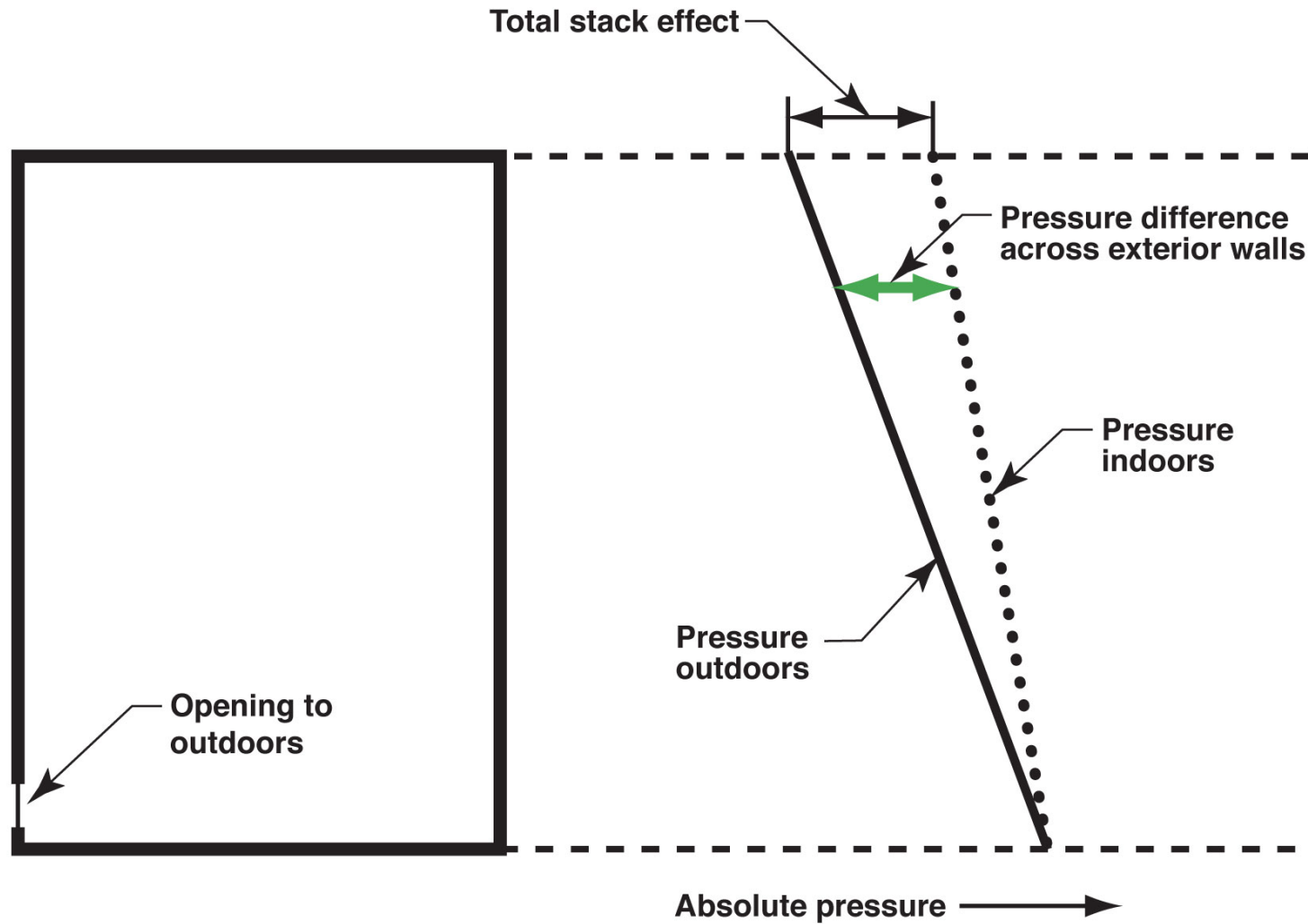

**Figure 11.1: Building with no internal separations with opening at the bottom
(Adapted from G.O. Handegord, 1998)**

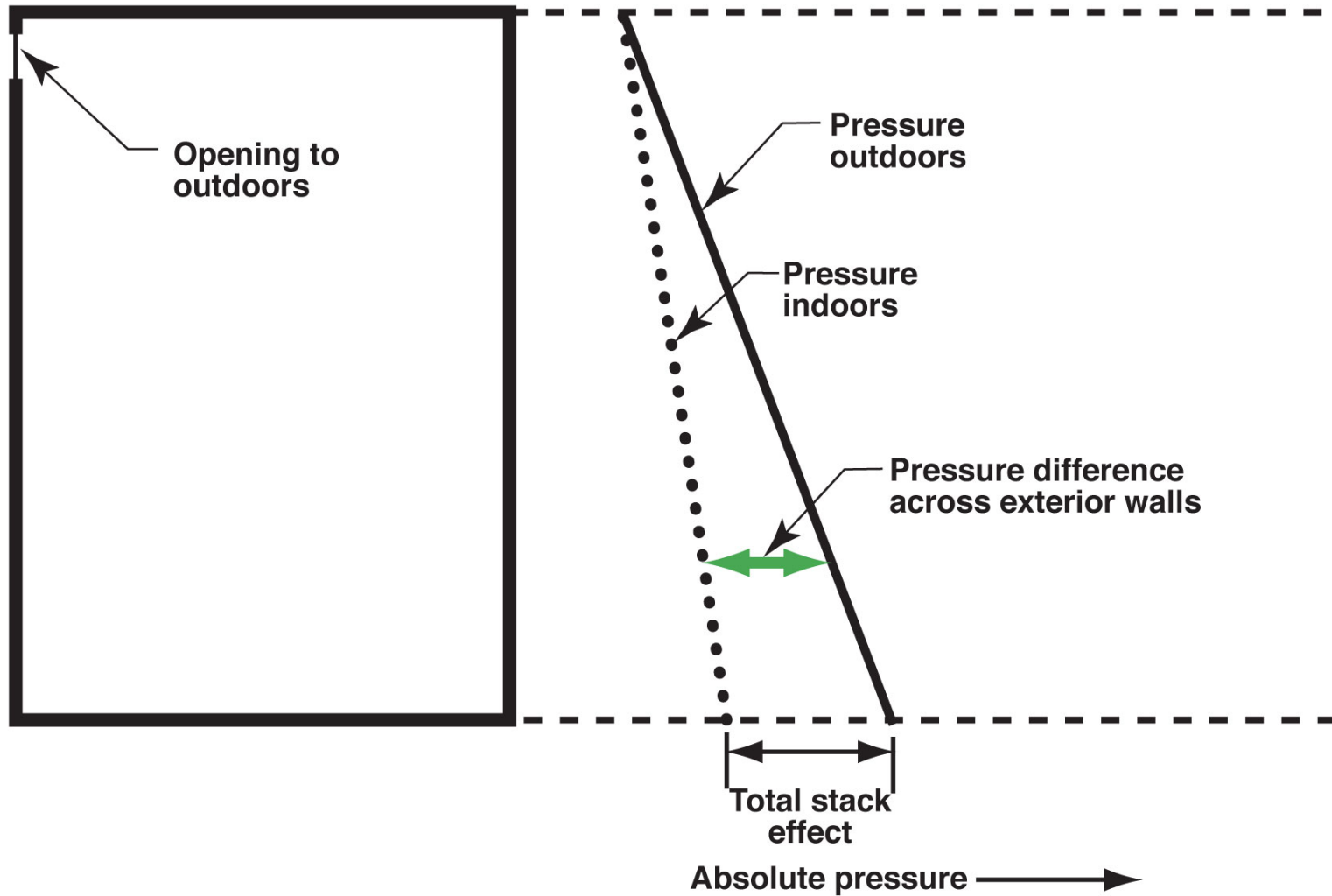

**Figure 11.2: Building with no internal separations with opening at the top
(Adapted from G.O. Handegord, 1998)**

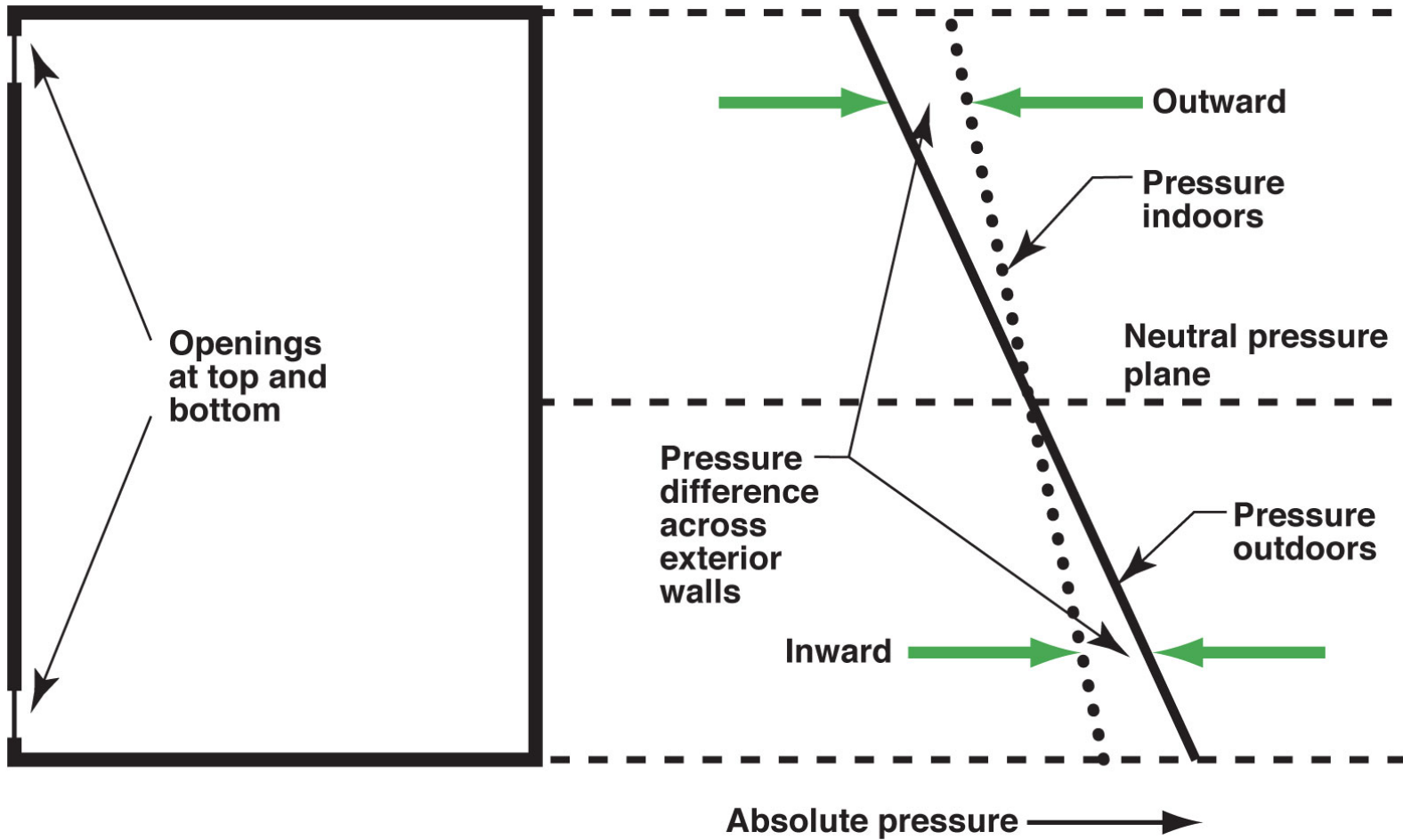
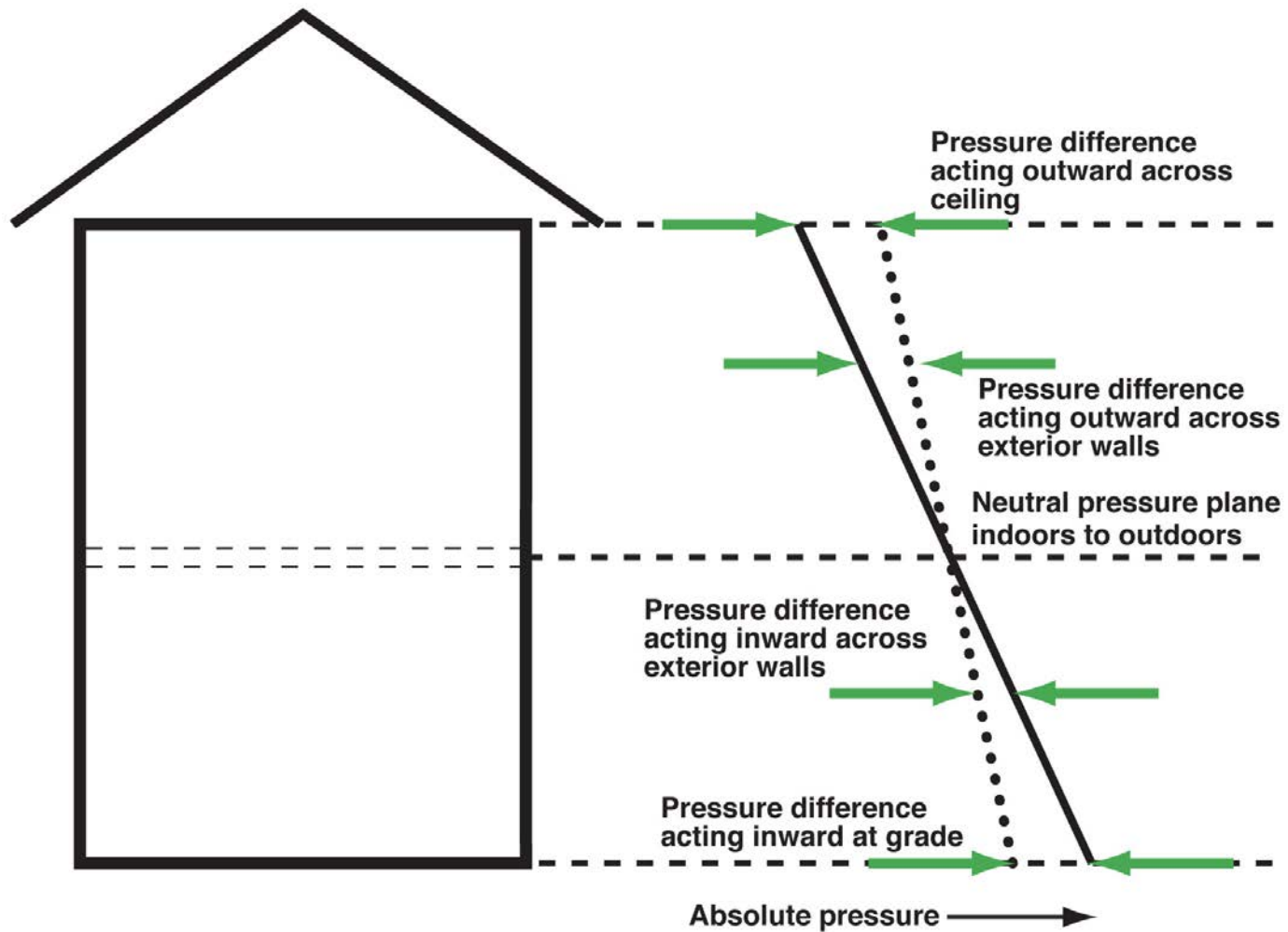

Figure 11.3: Building with no internal separations with openings at top and bottom (Adapted from G.O. Handegord, 1998)



**Figure 11.4: Basic two storey house with vented attic
(Adapted from G.O. Handegord, 1998)**





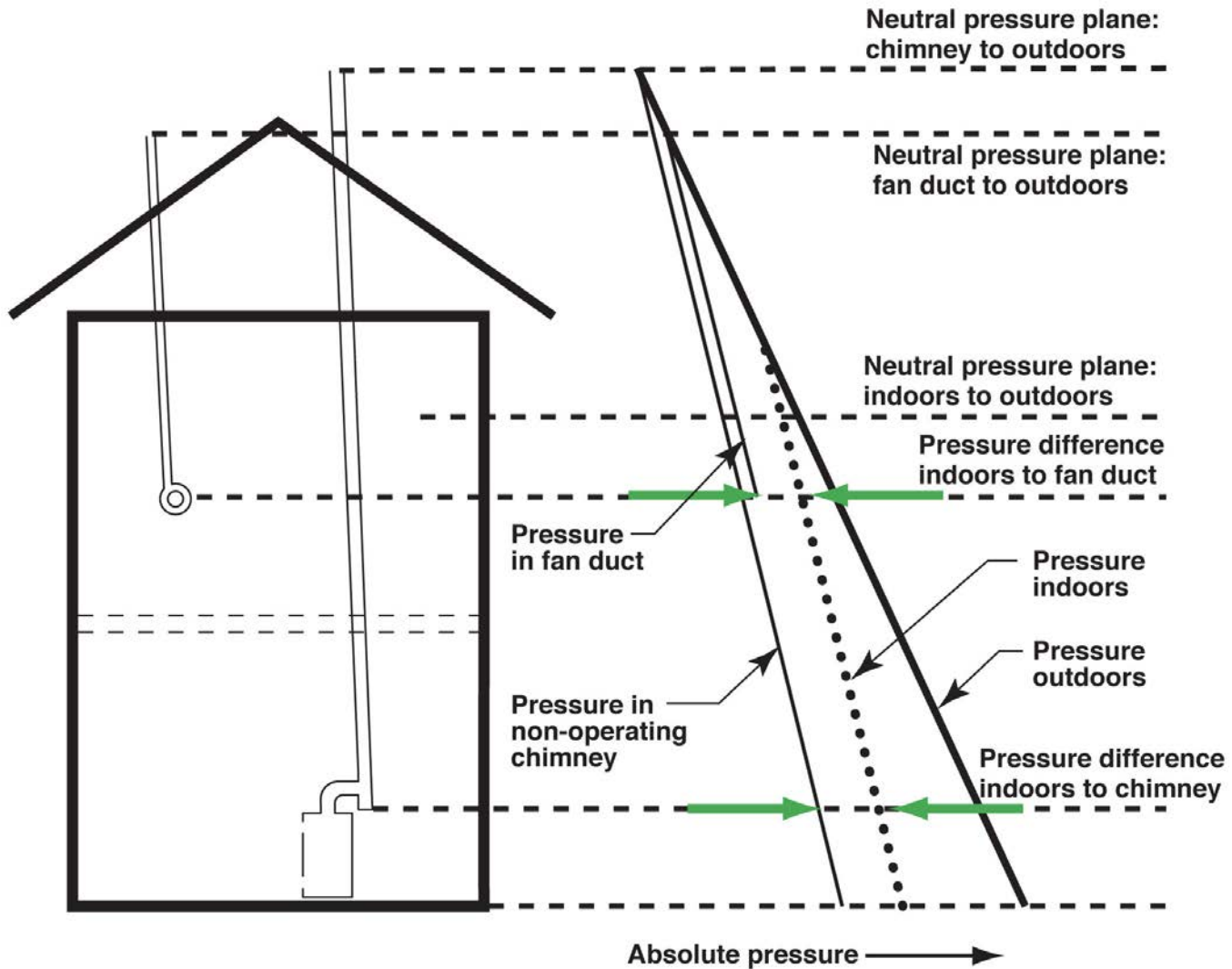

**Figure 11.5: Two storey house with non-operating chimney and exhaust fan
(Adapted from G.O. Handegord, 1998)**

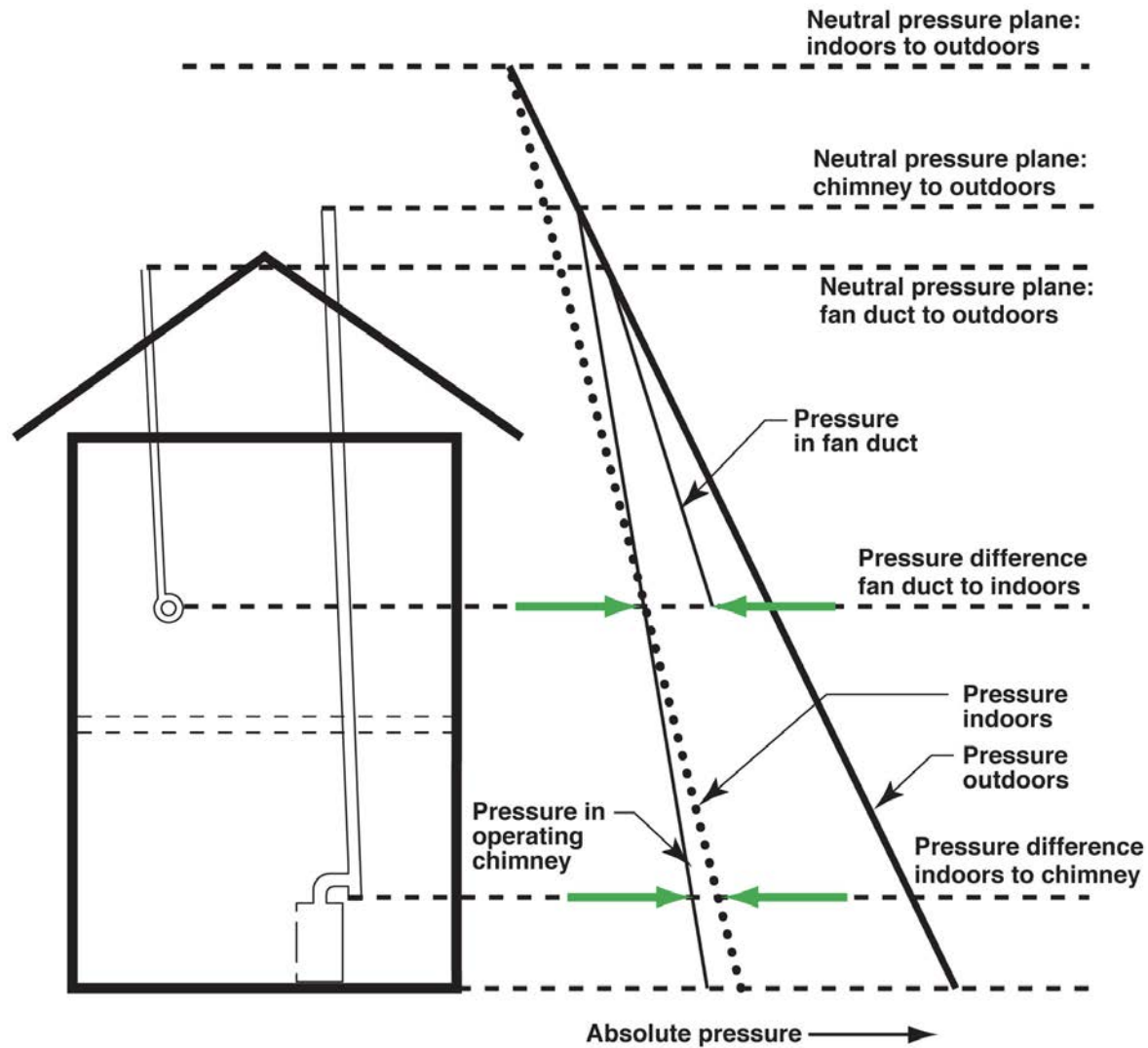
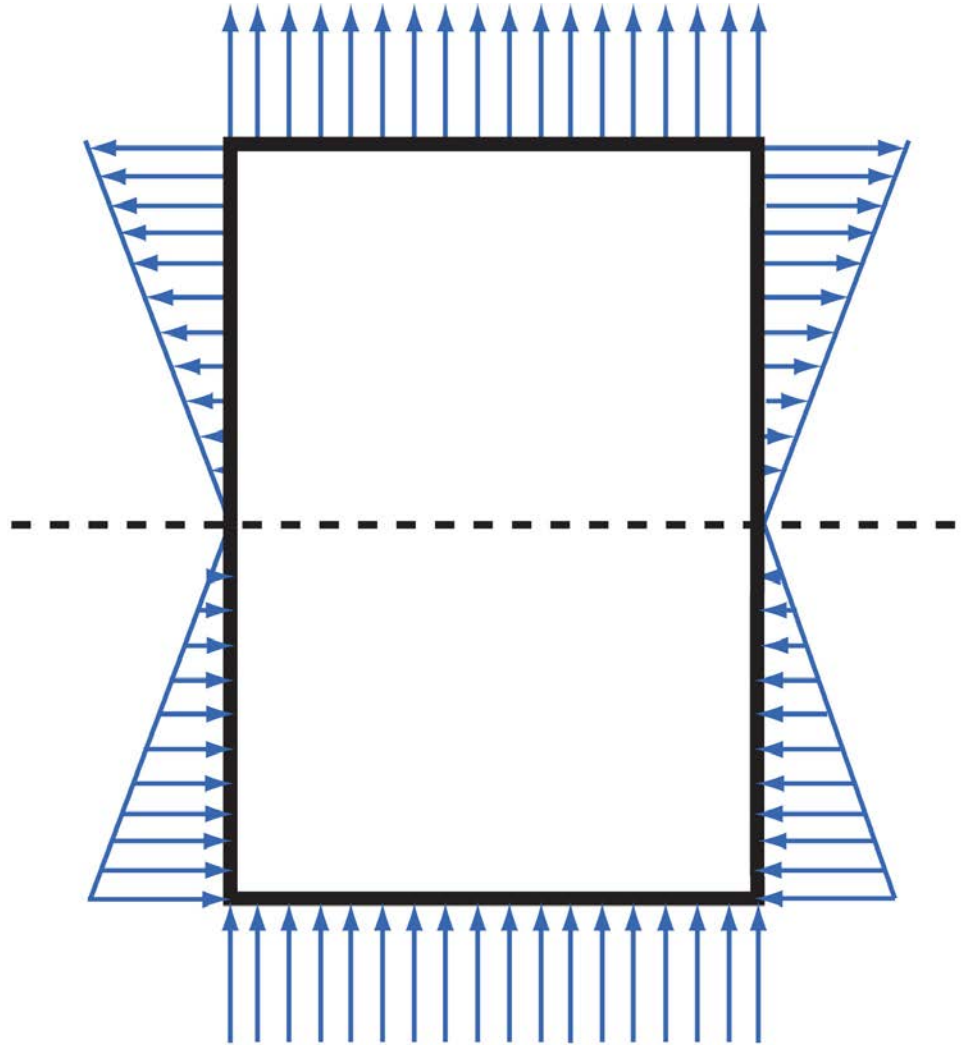
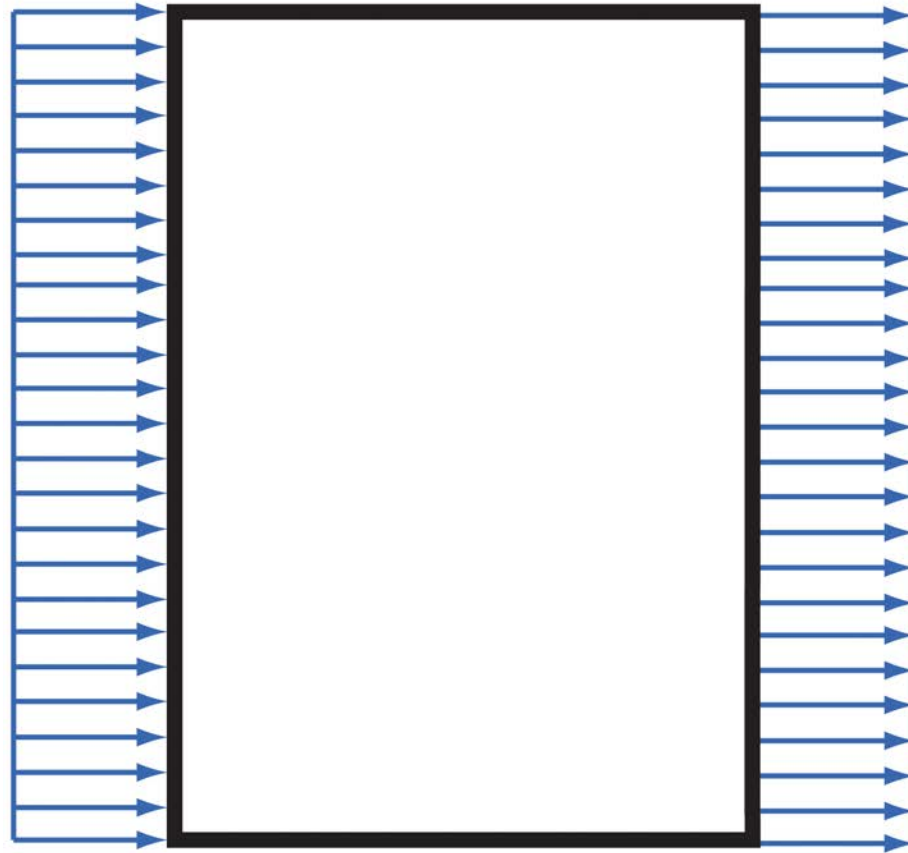

Figure 11.6: Two storey house with operating chimney
(Adapted from G.O. Handegord, 1998)



Stack effect



Wind

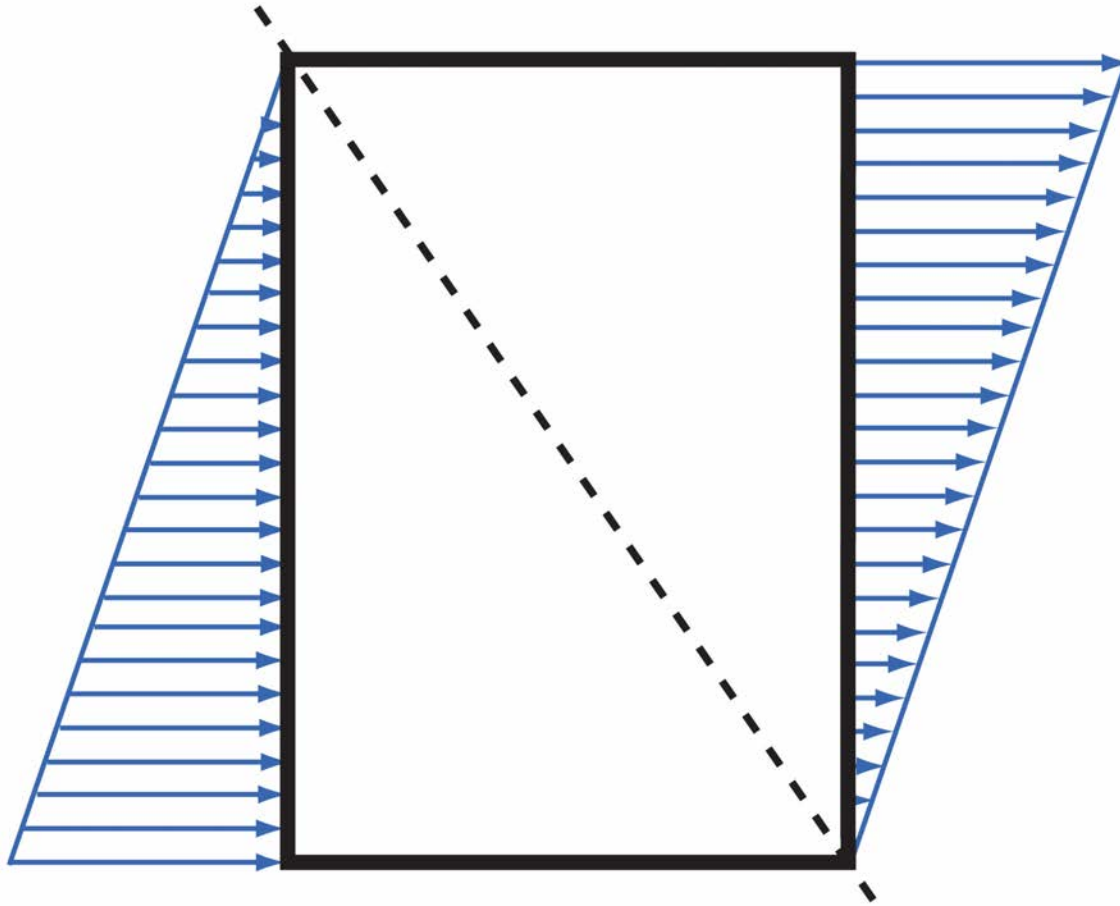

Stack effect and wind

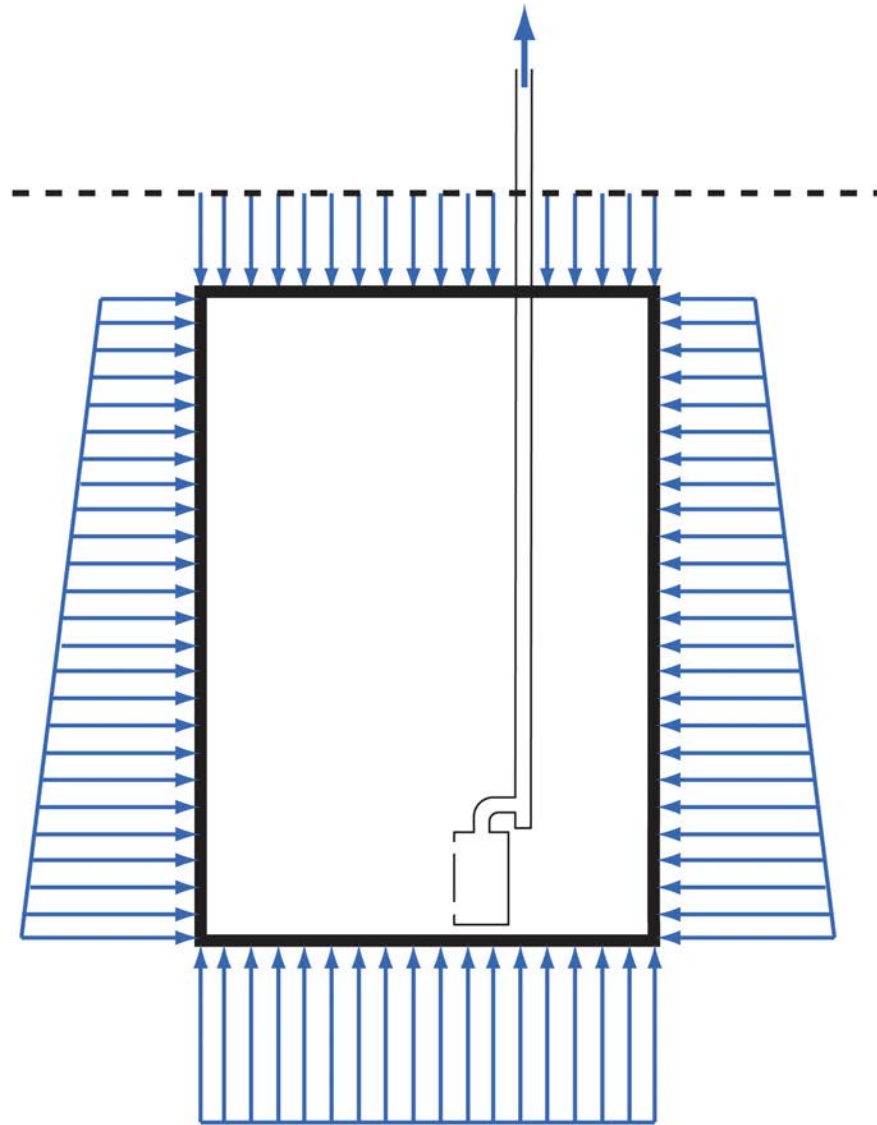

Chimney effect

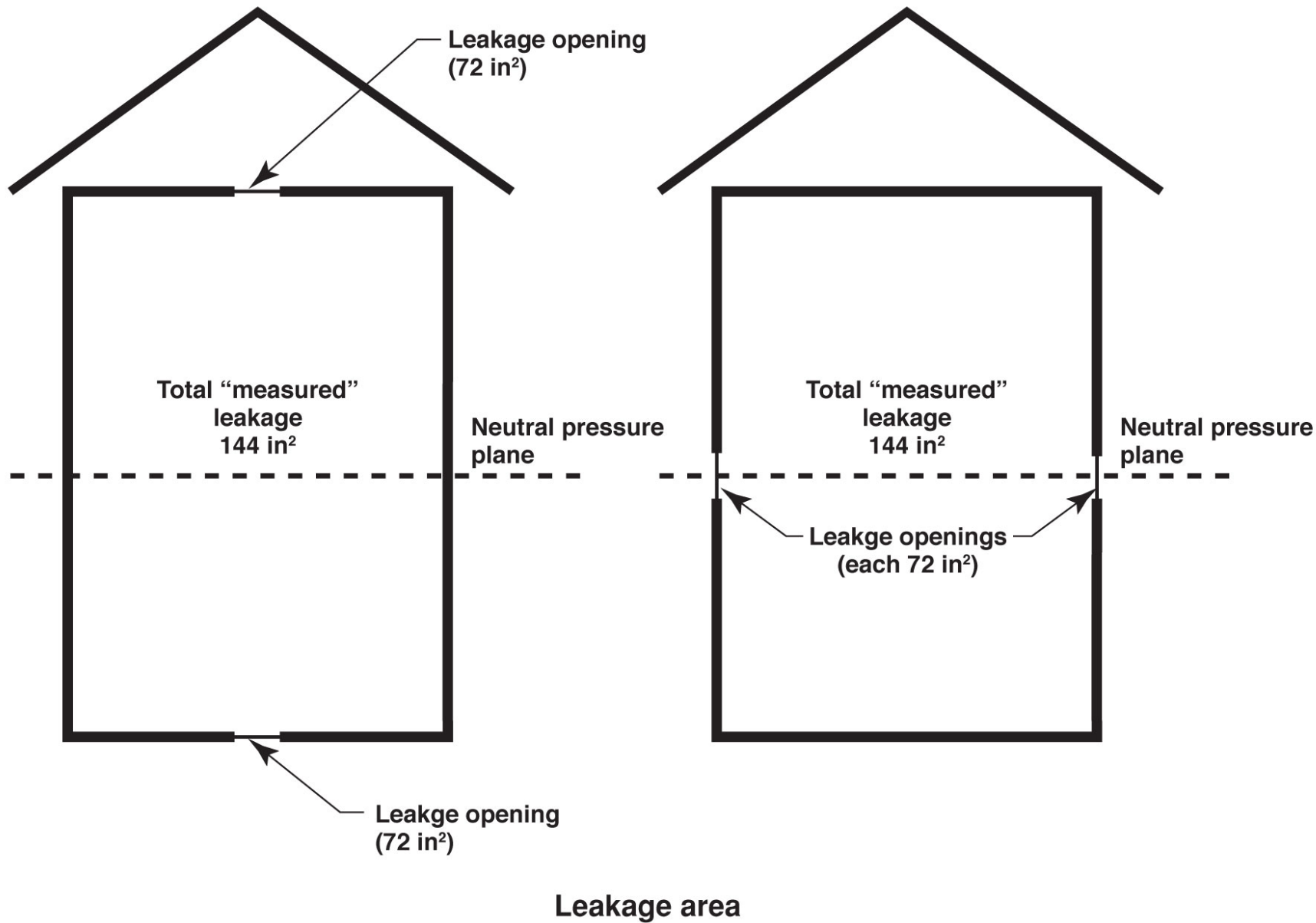

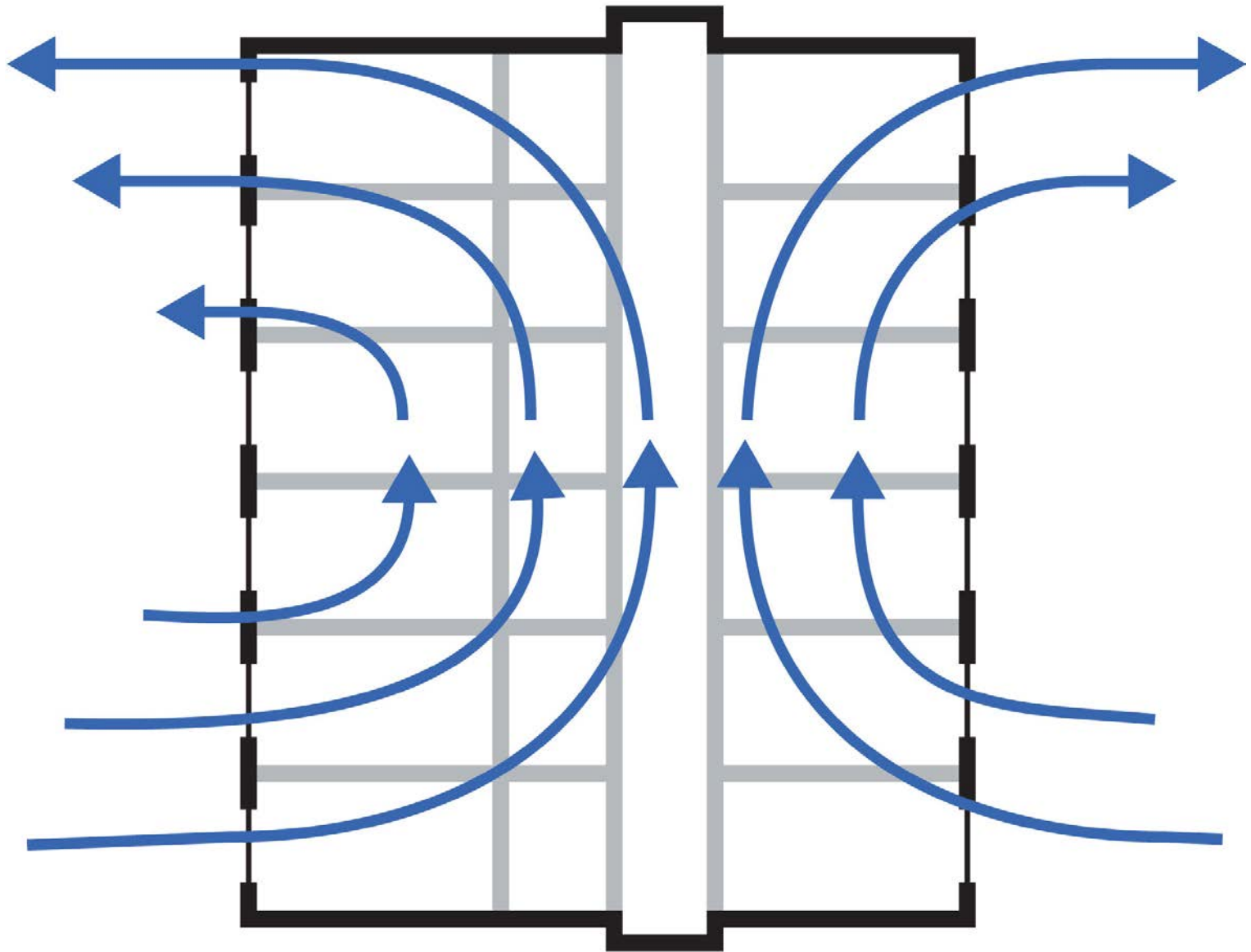

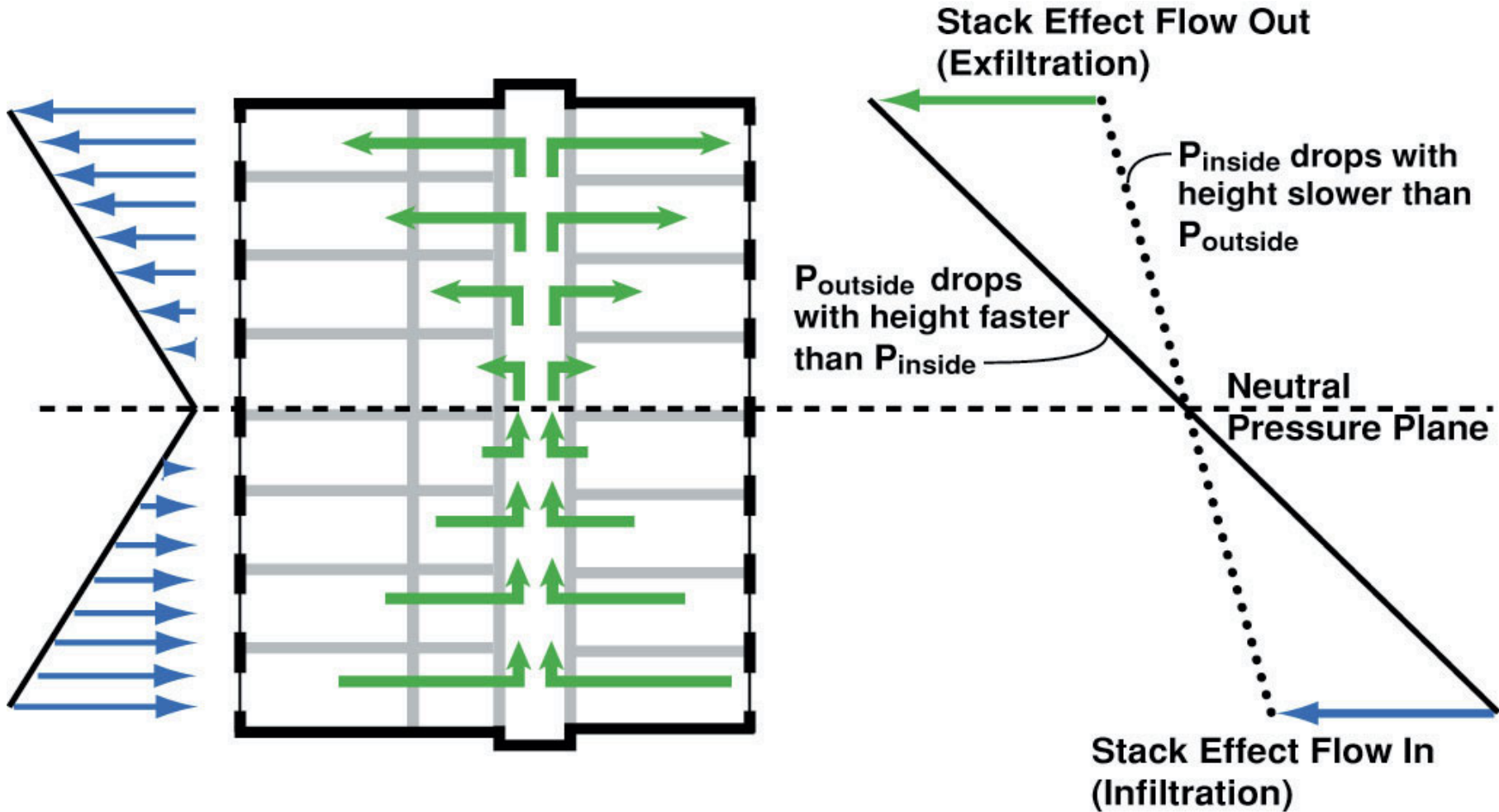

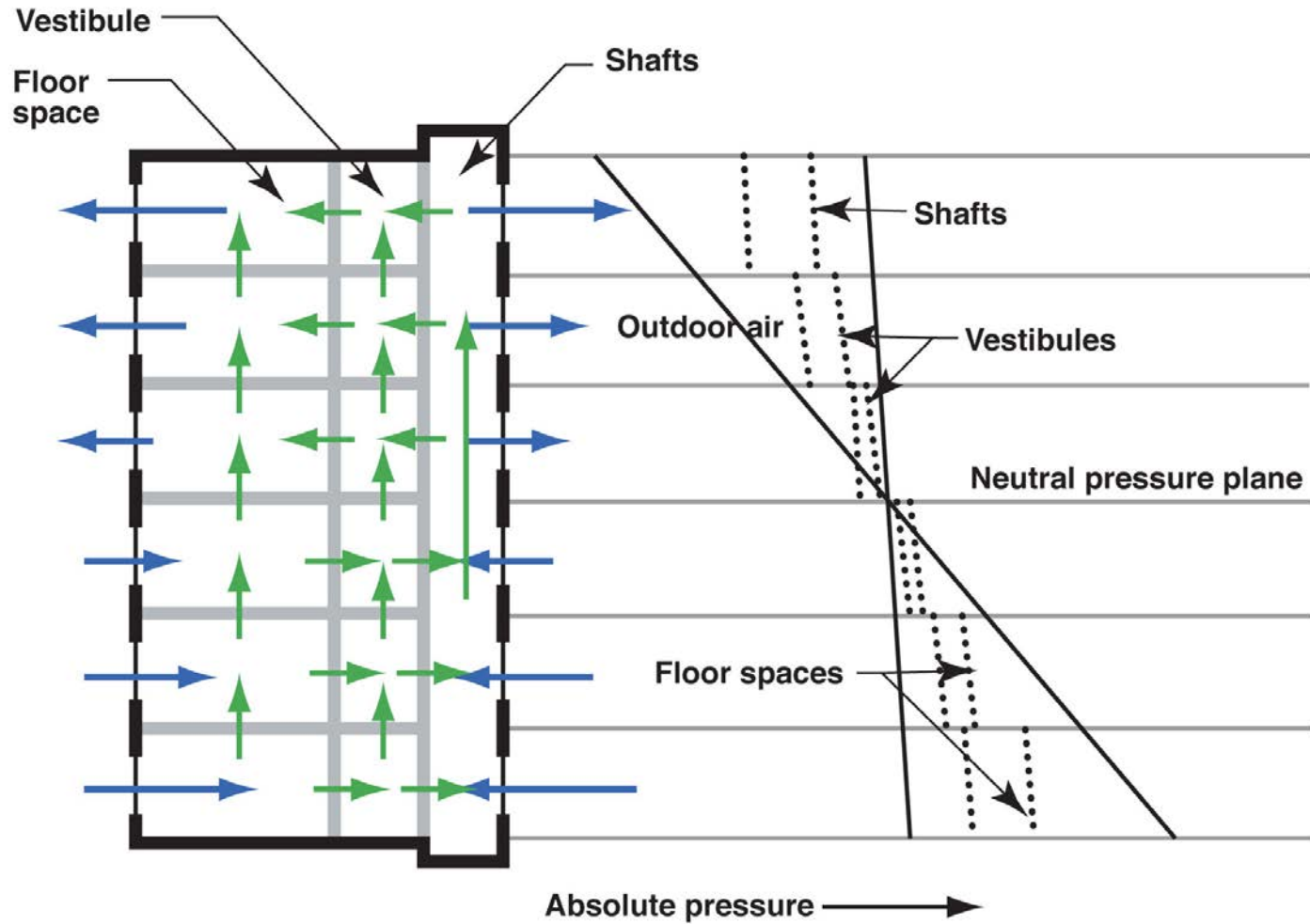

**Figure 11.8: Stack effect pressures in high rise office building
(Adapted from G.O. Handegord, 1998)**

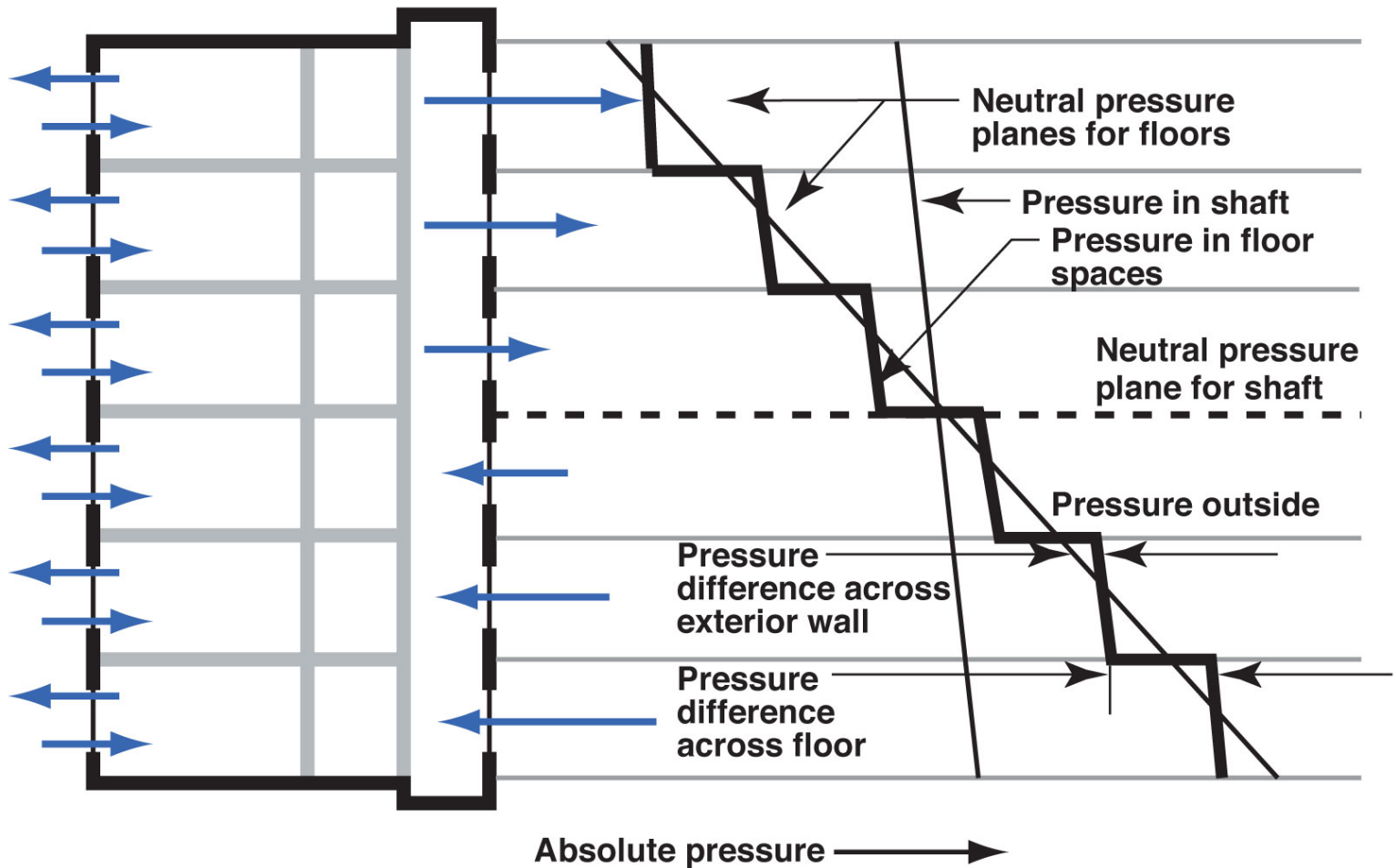
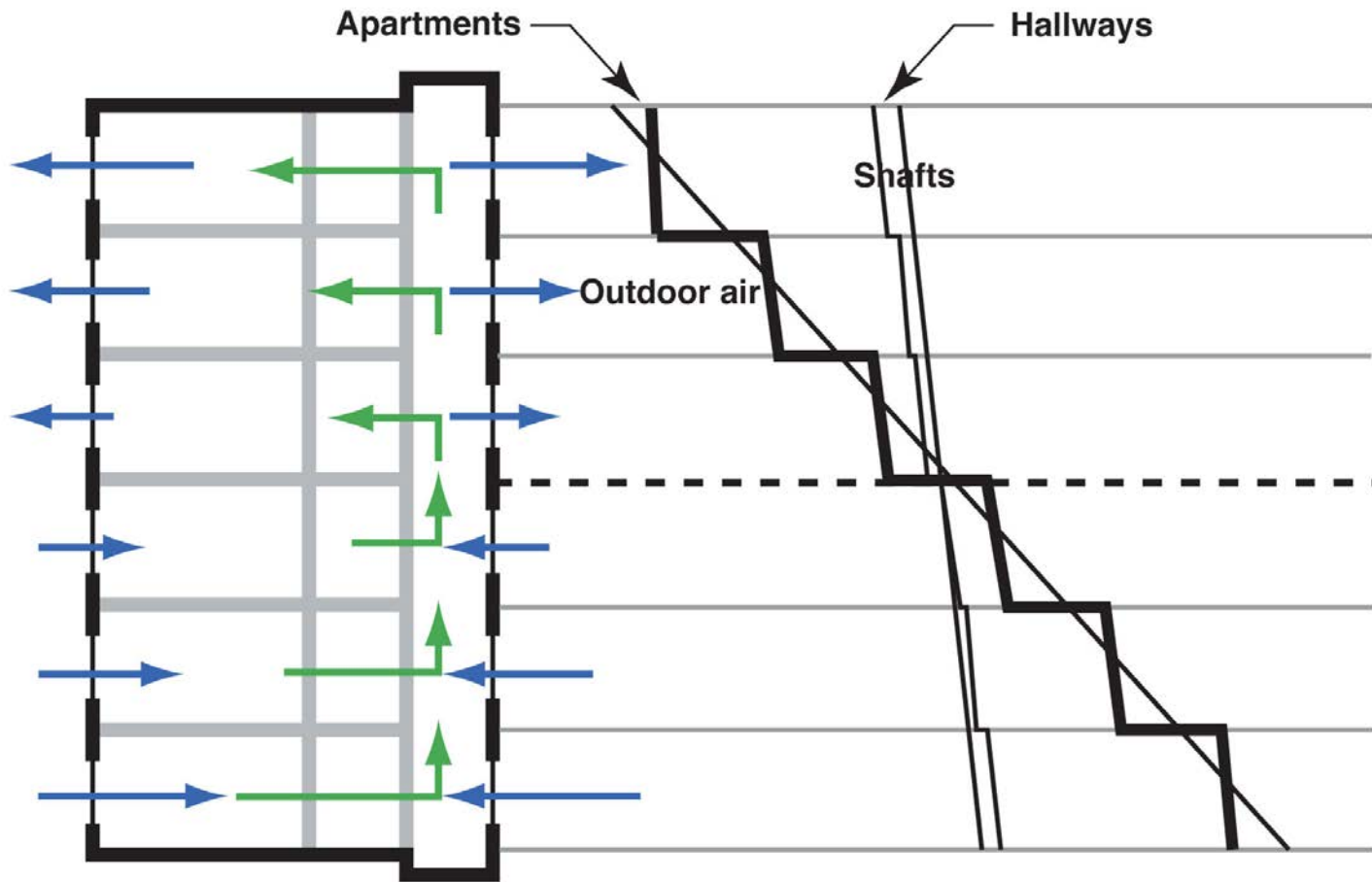
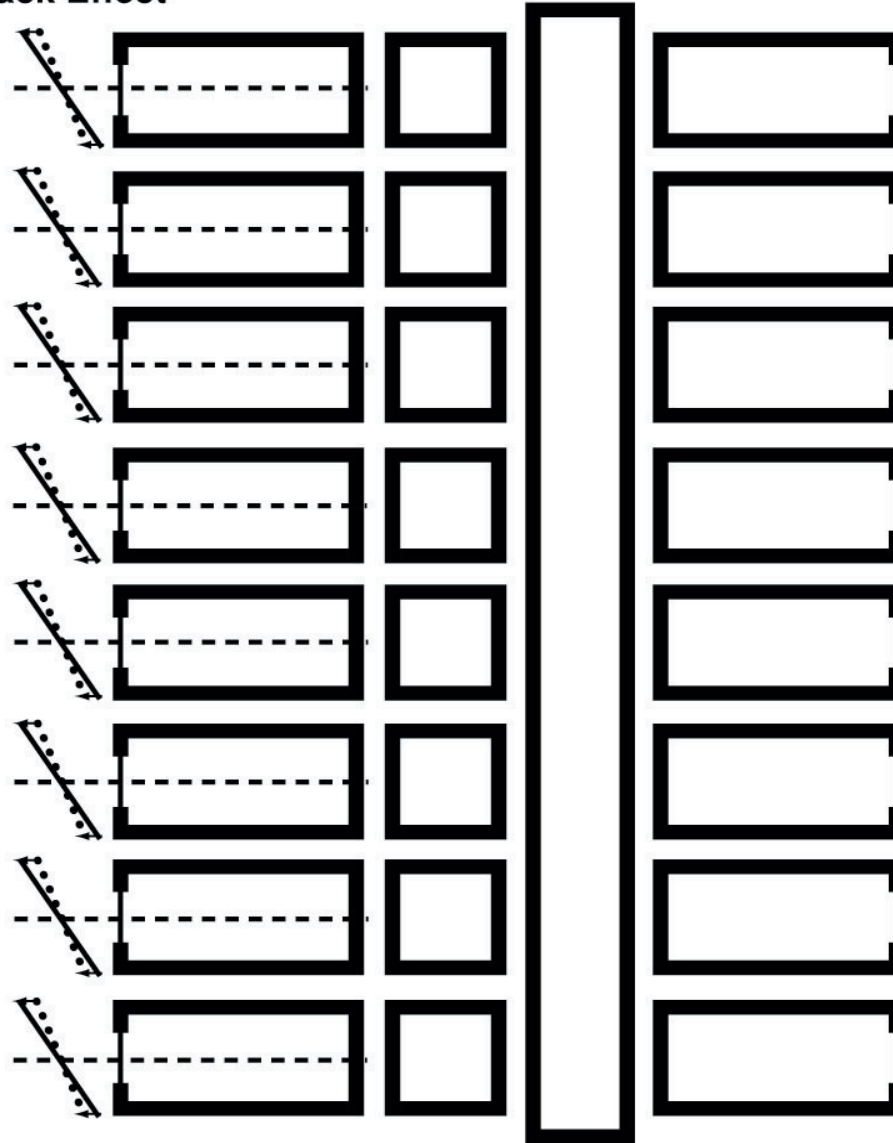

Figure 11.9: Multi-storey building with floor spaces isolated from vertical shafts (Adapted from G.O. Handegord, 1998)



**Figure 11.12: Apartment building with tighter apartment entry doors
(Adapted from G.O. Handegord, 1998)**

Reduced Individual Unit Stack Effect



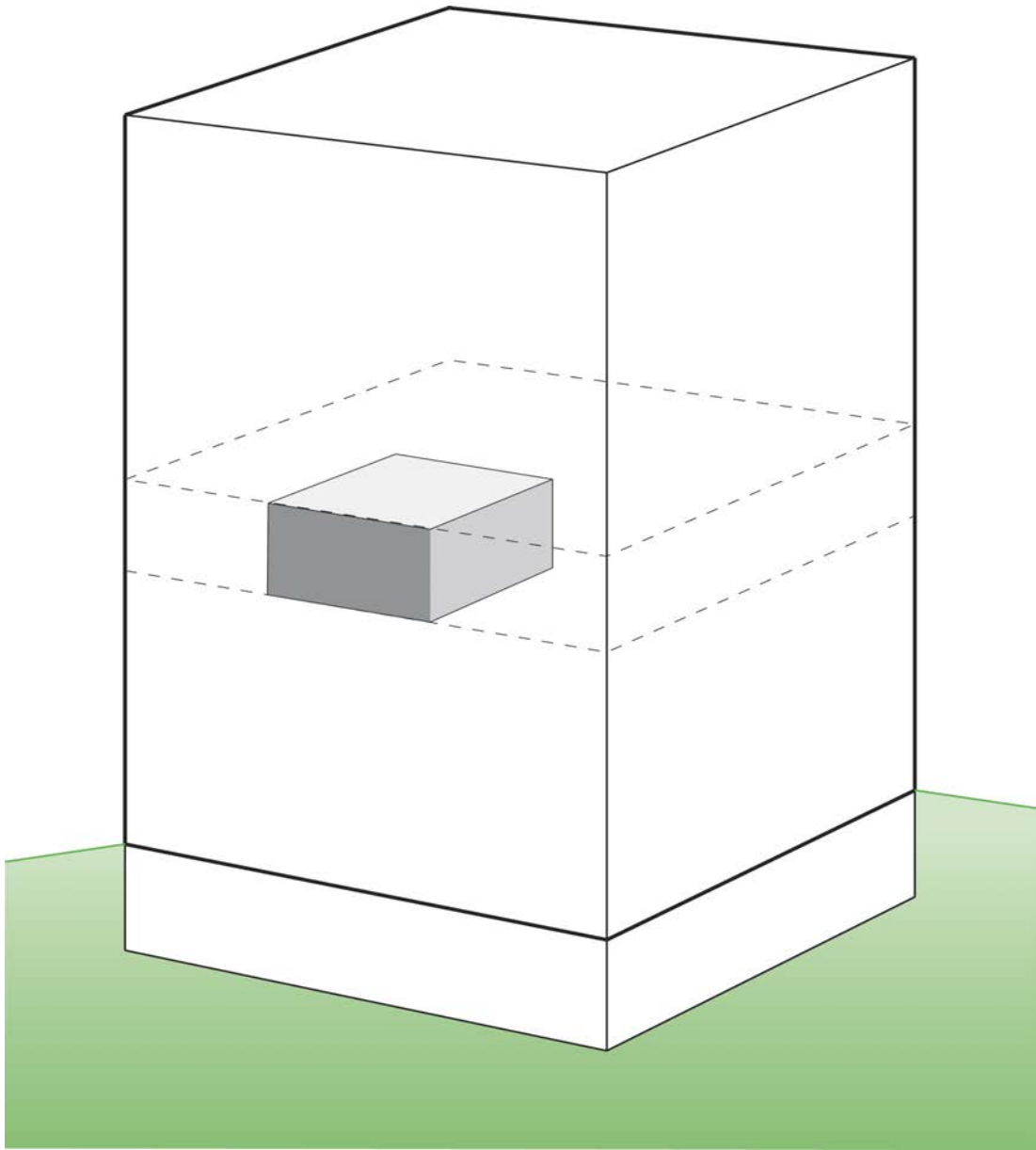





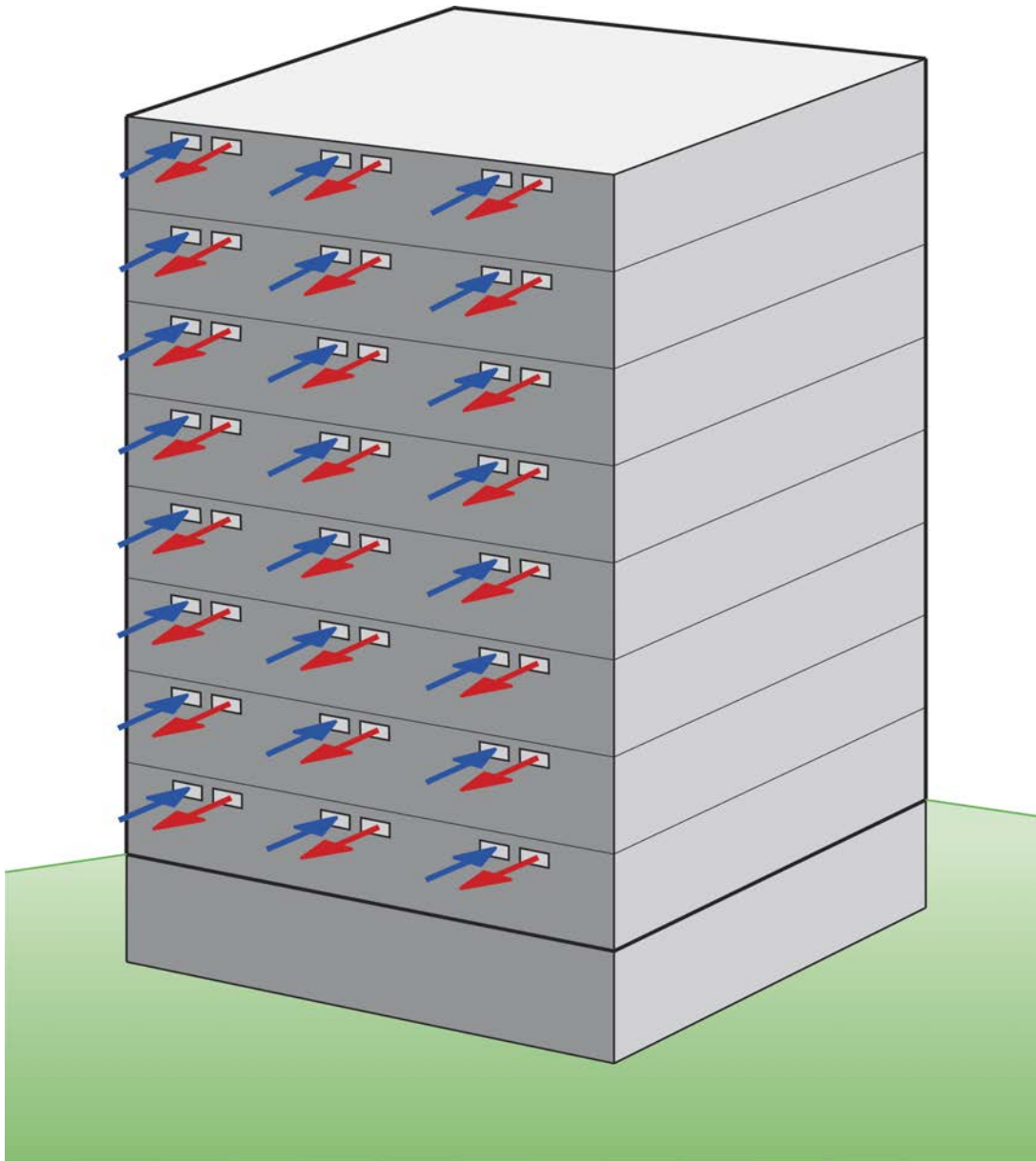

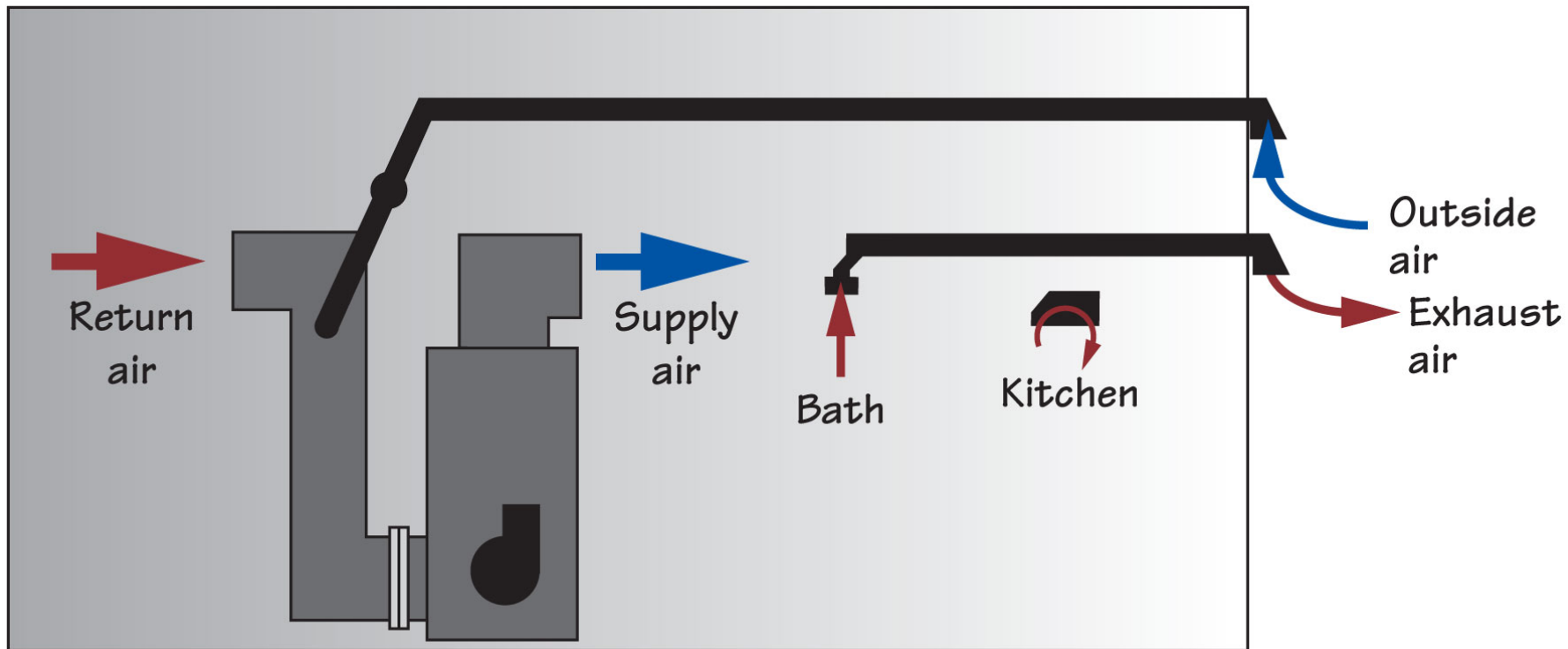

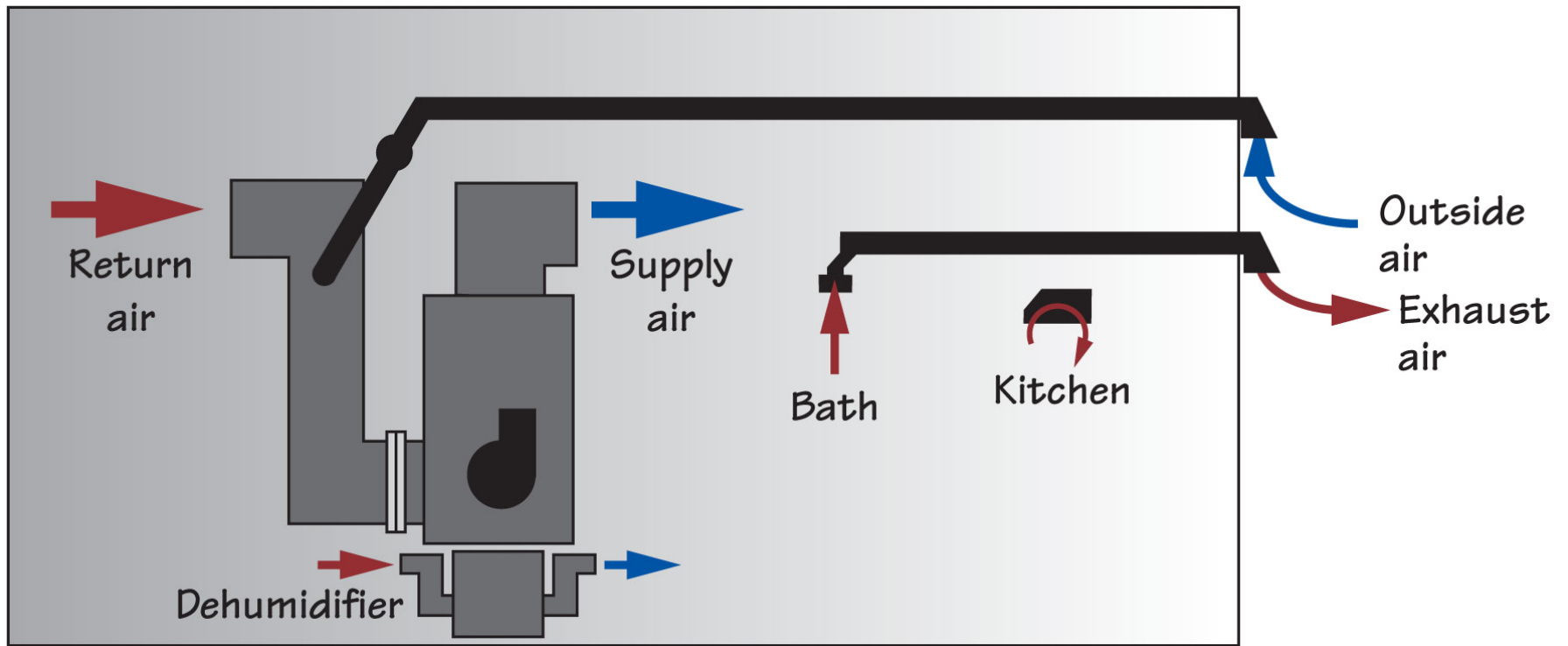

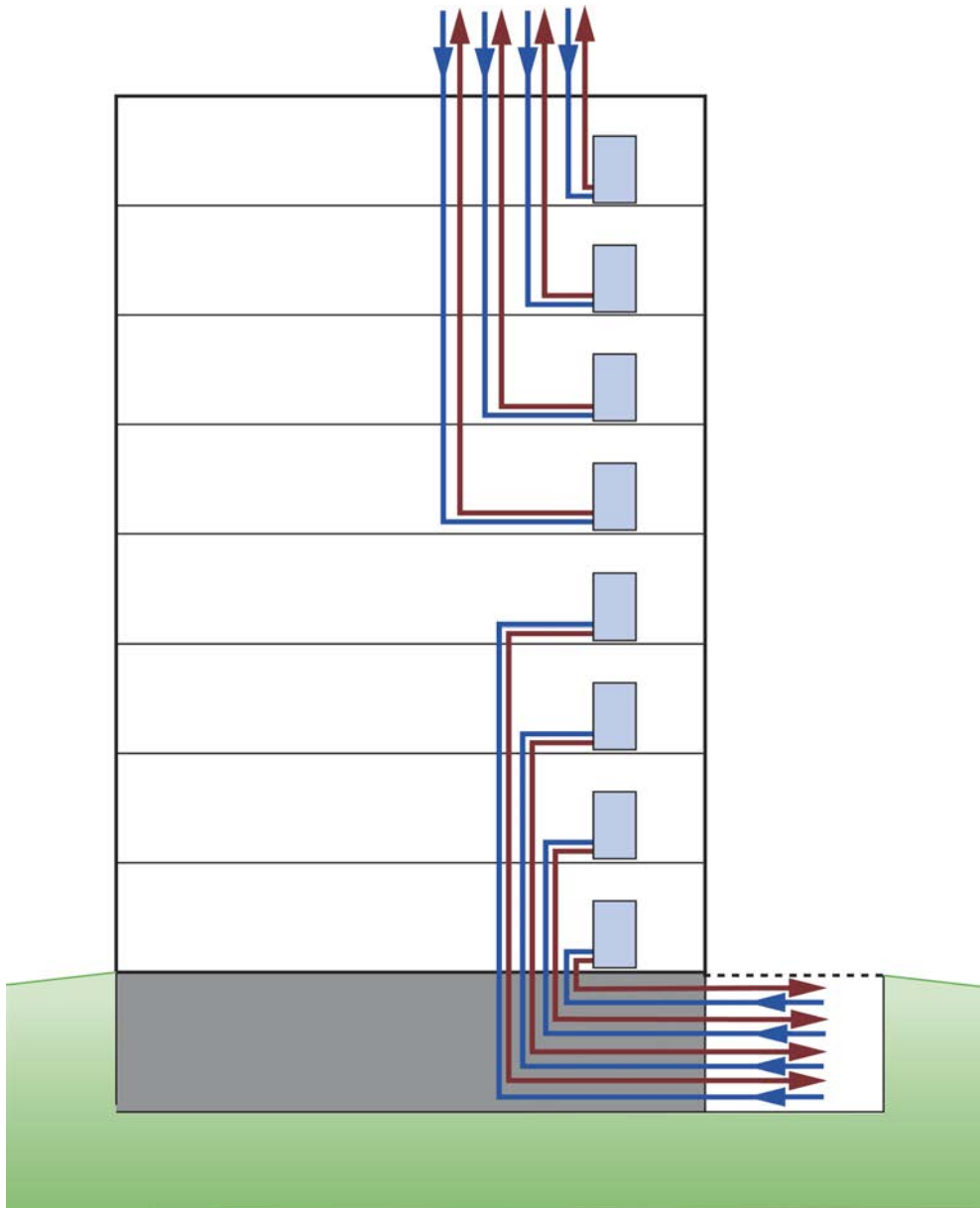

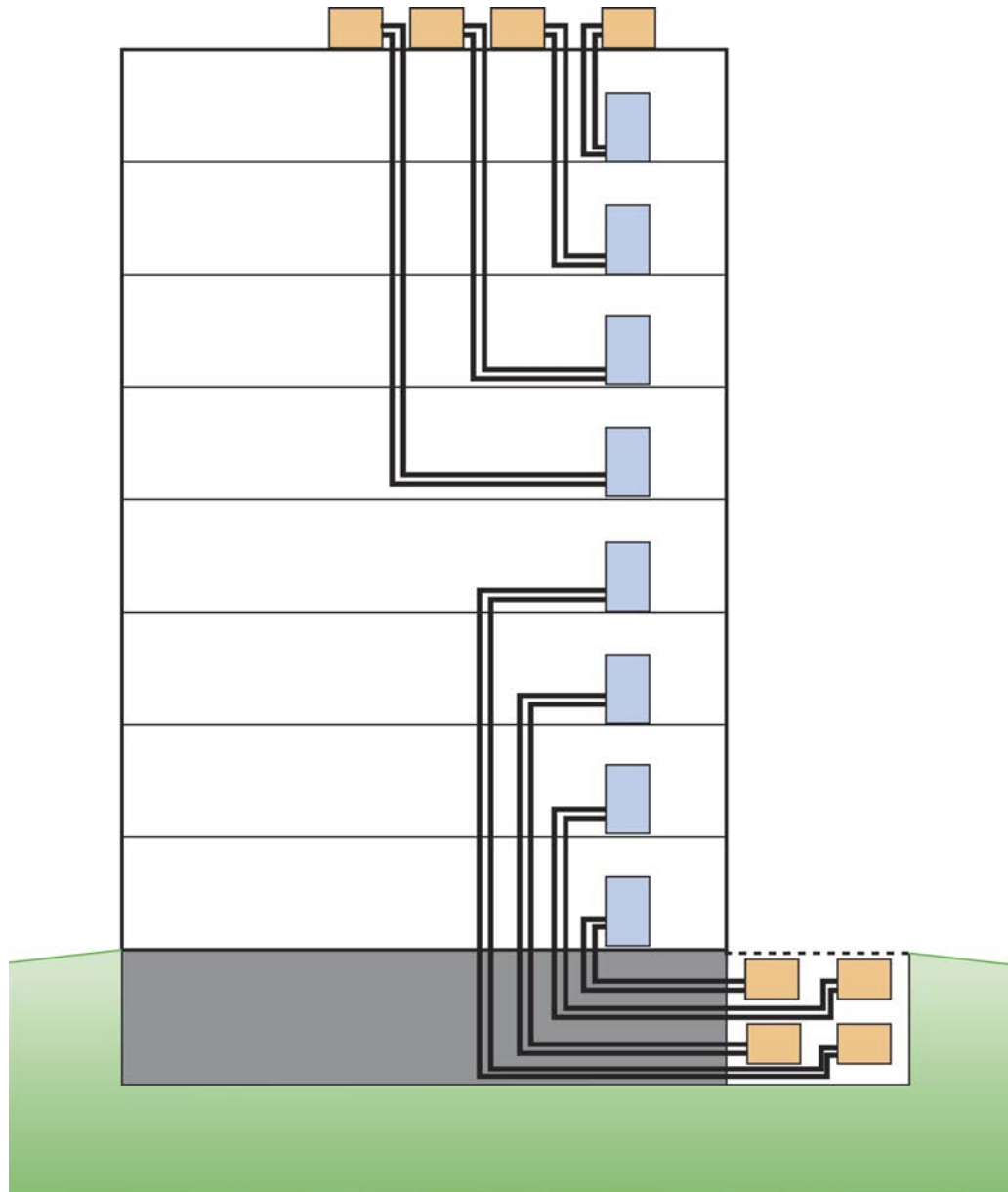

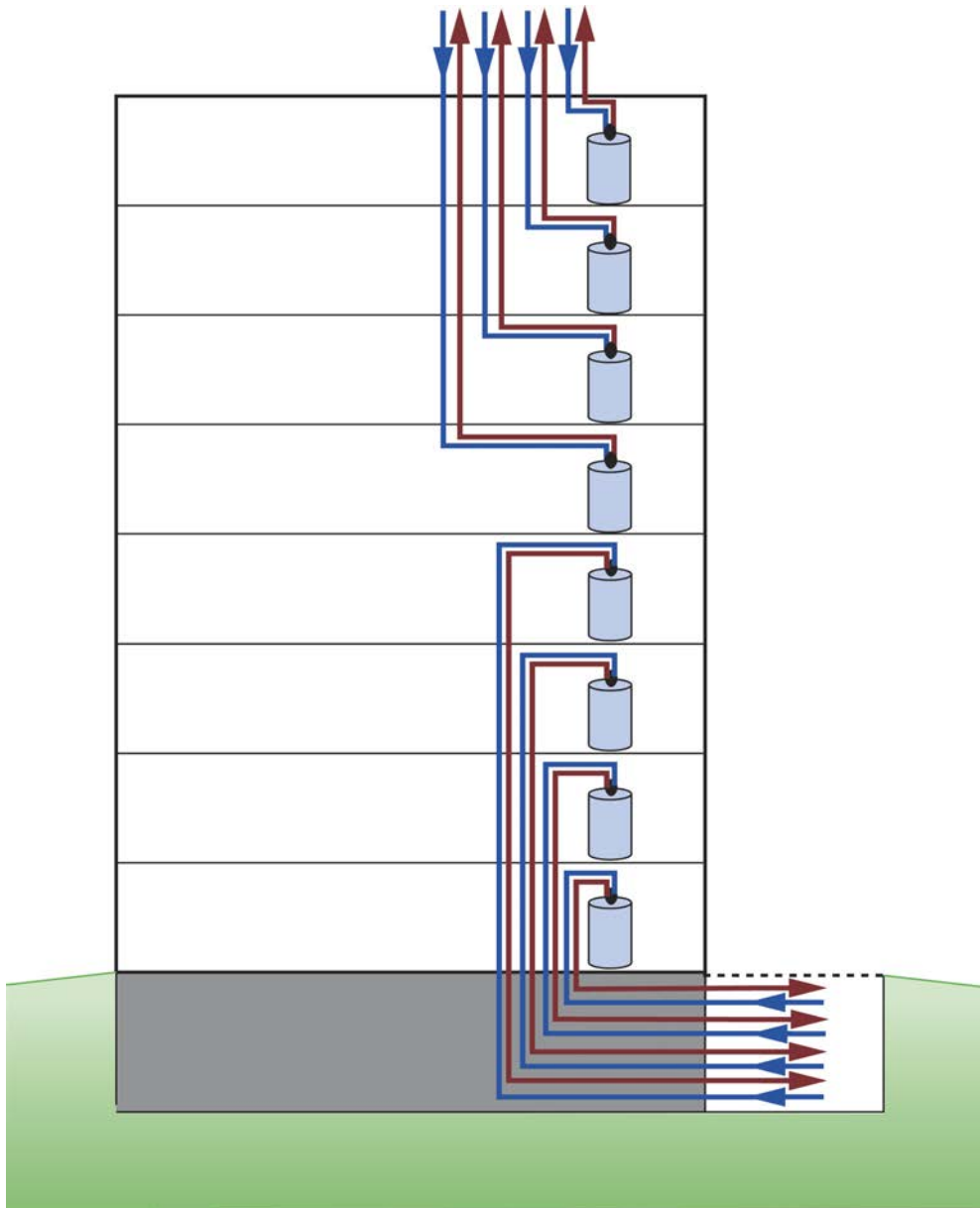

















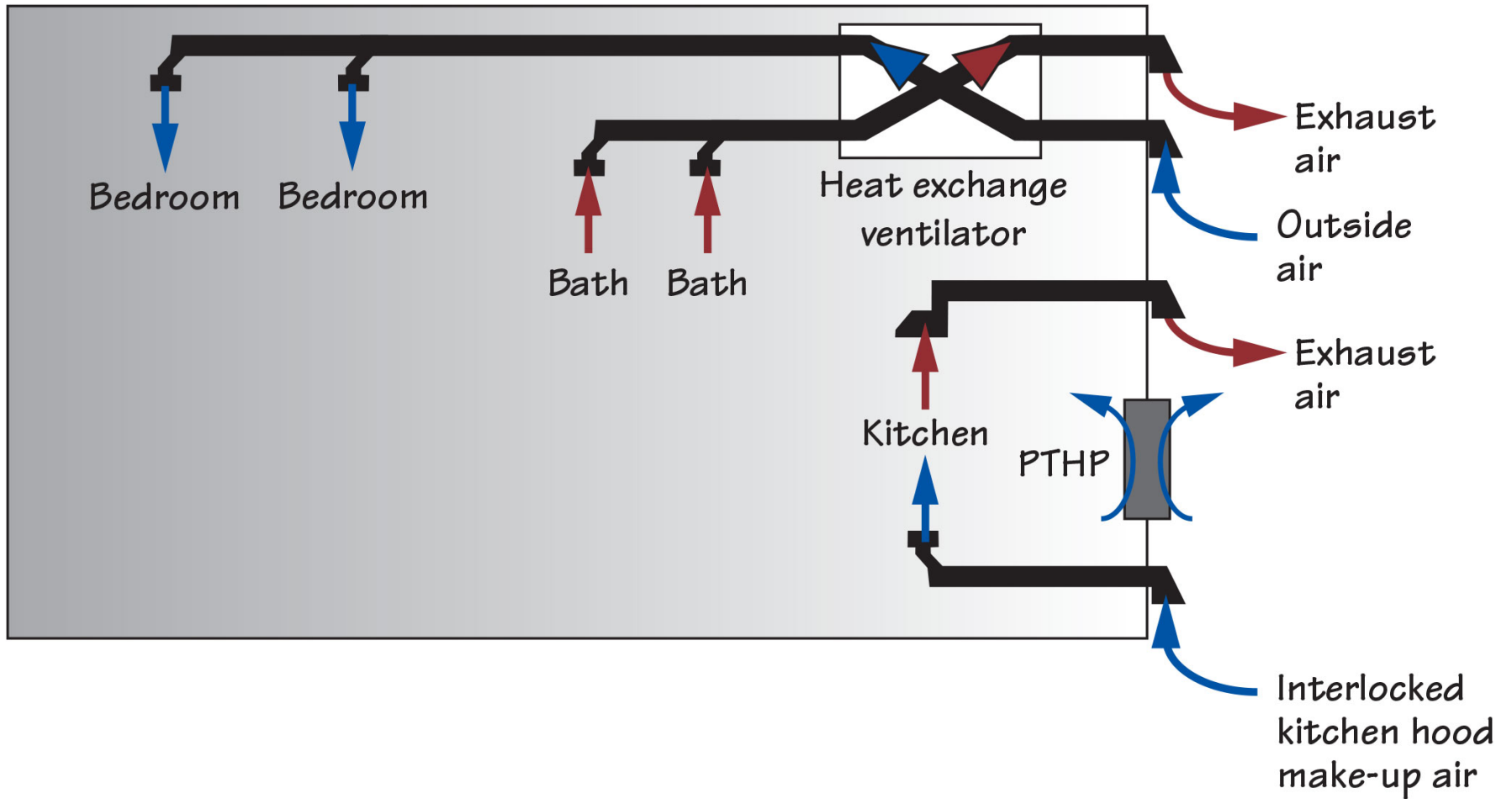

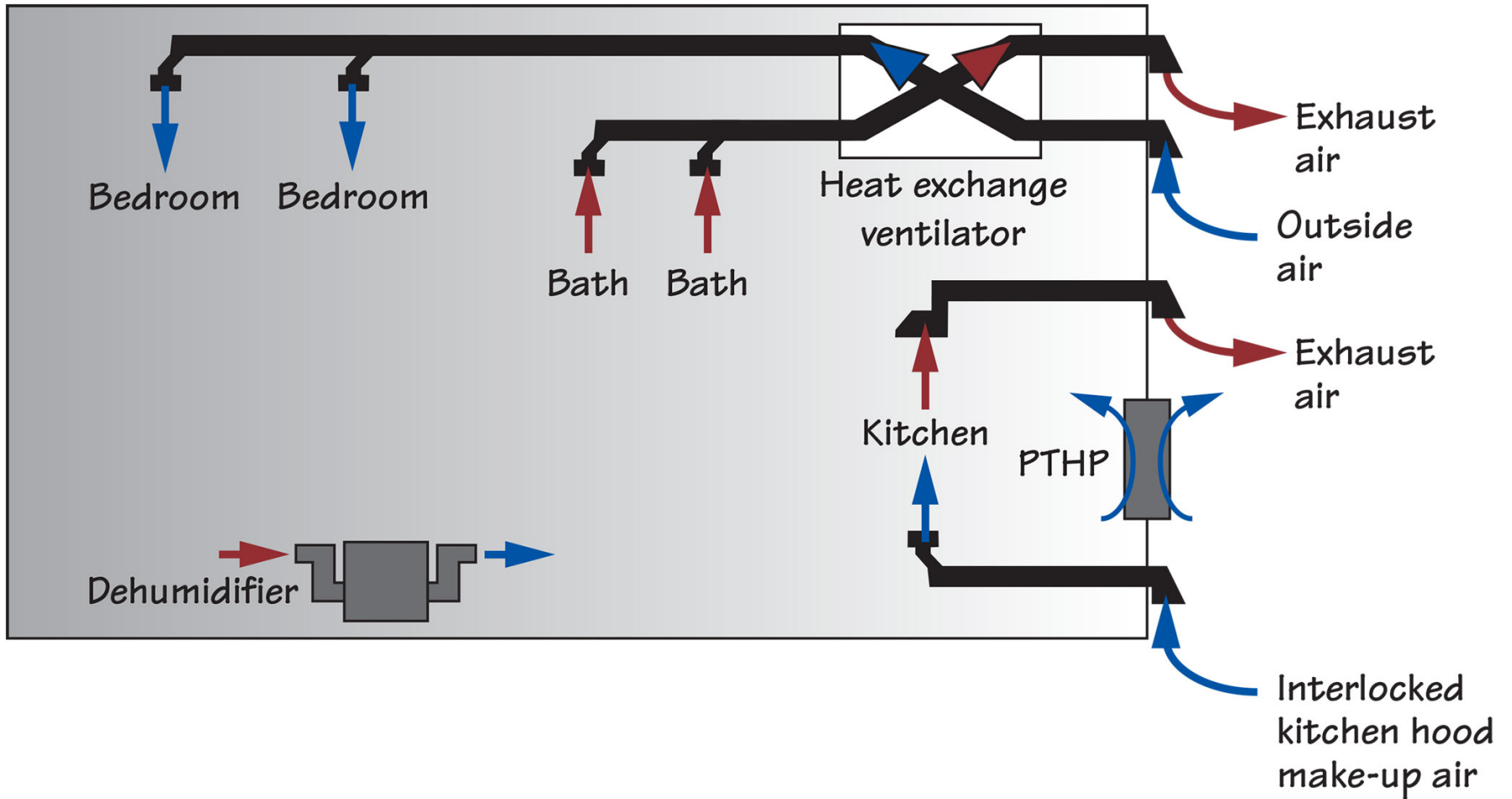





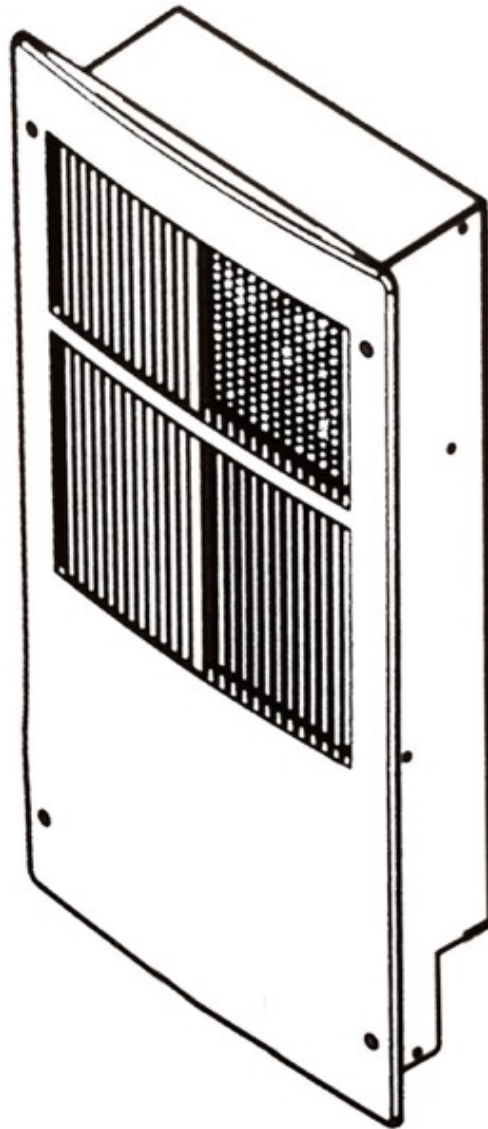



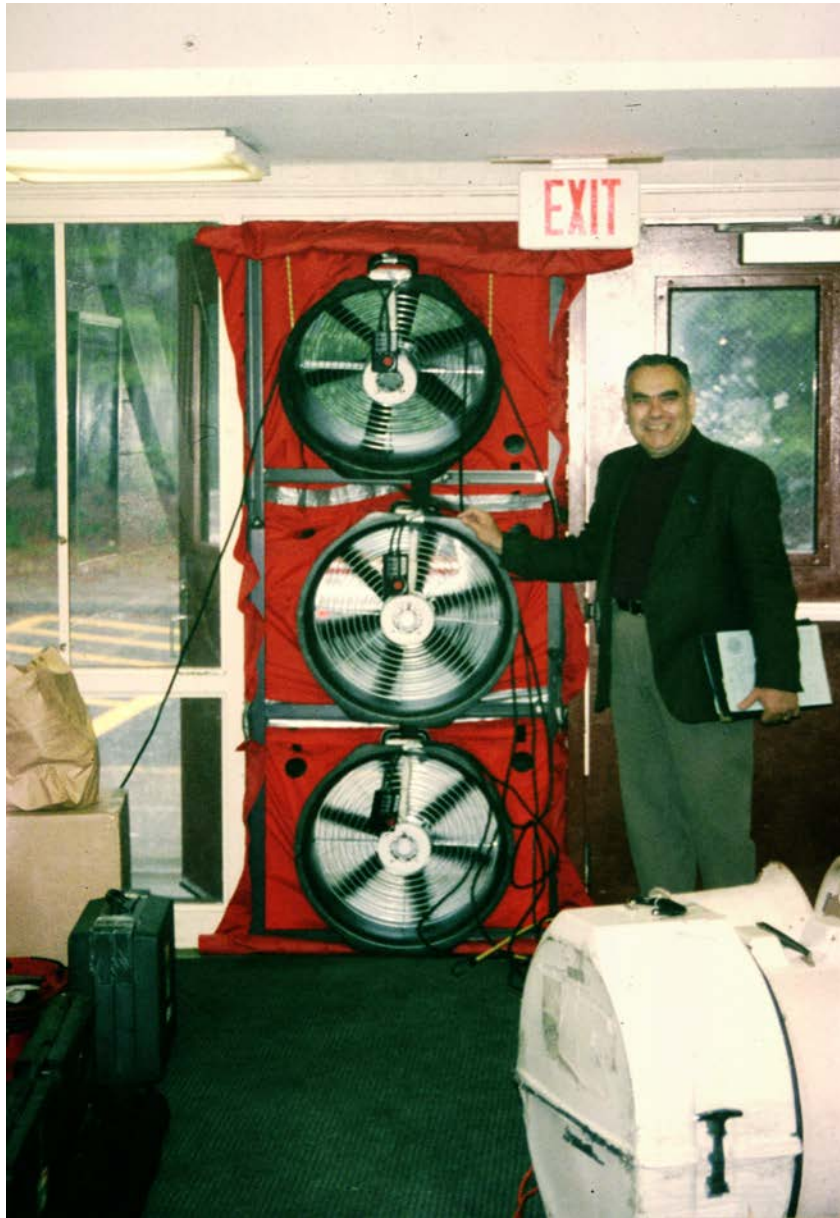











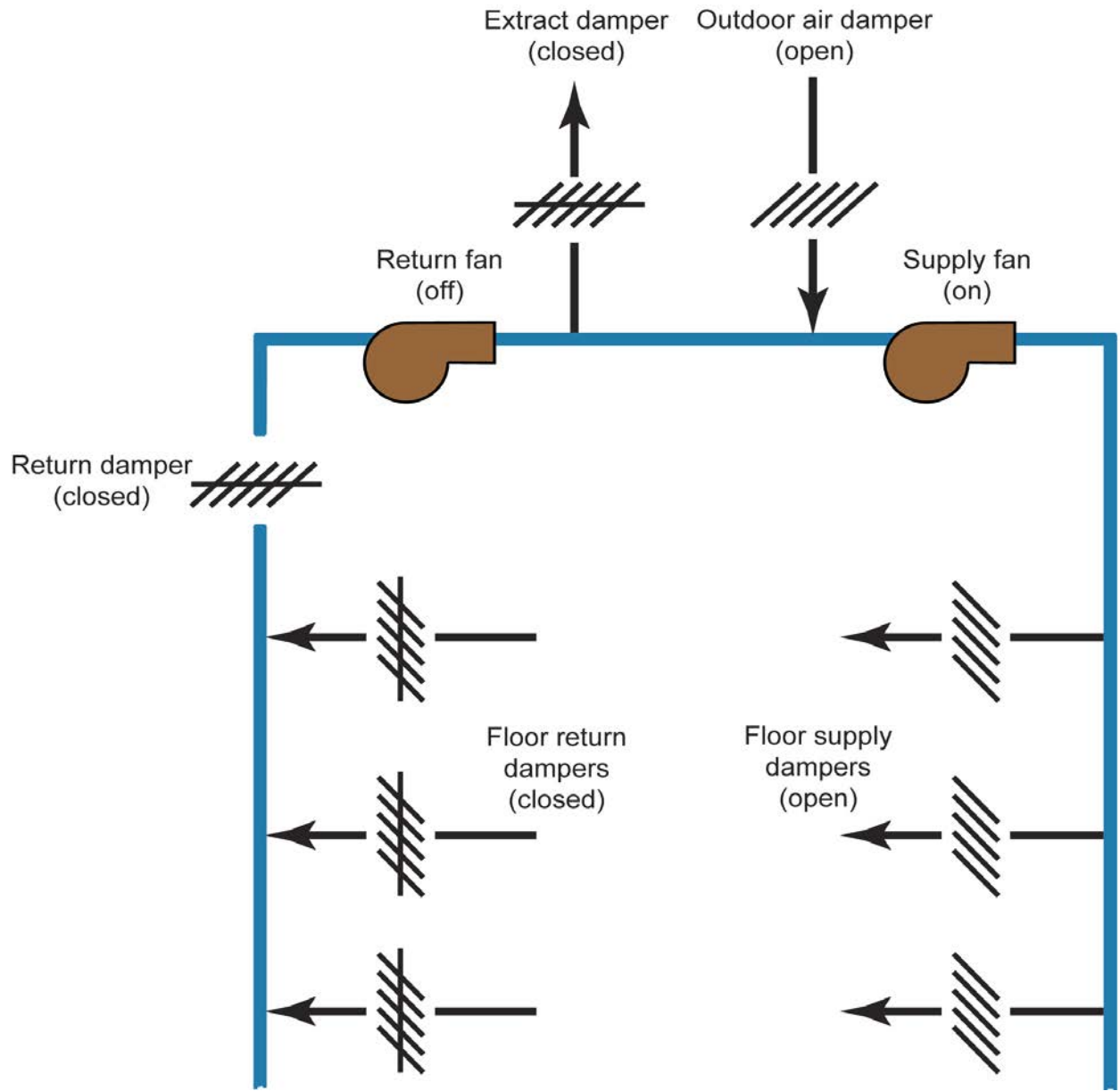

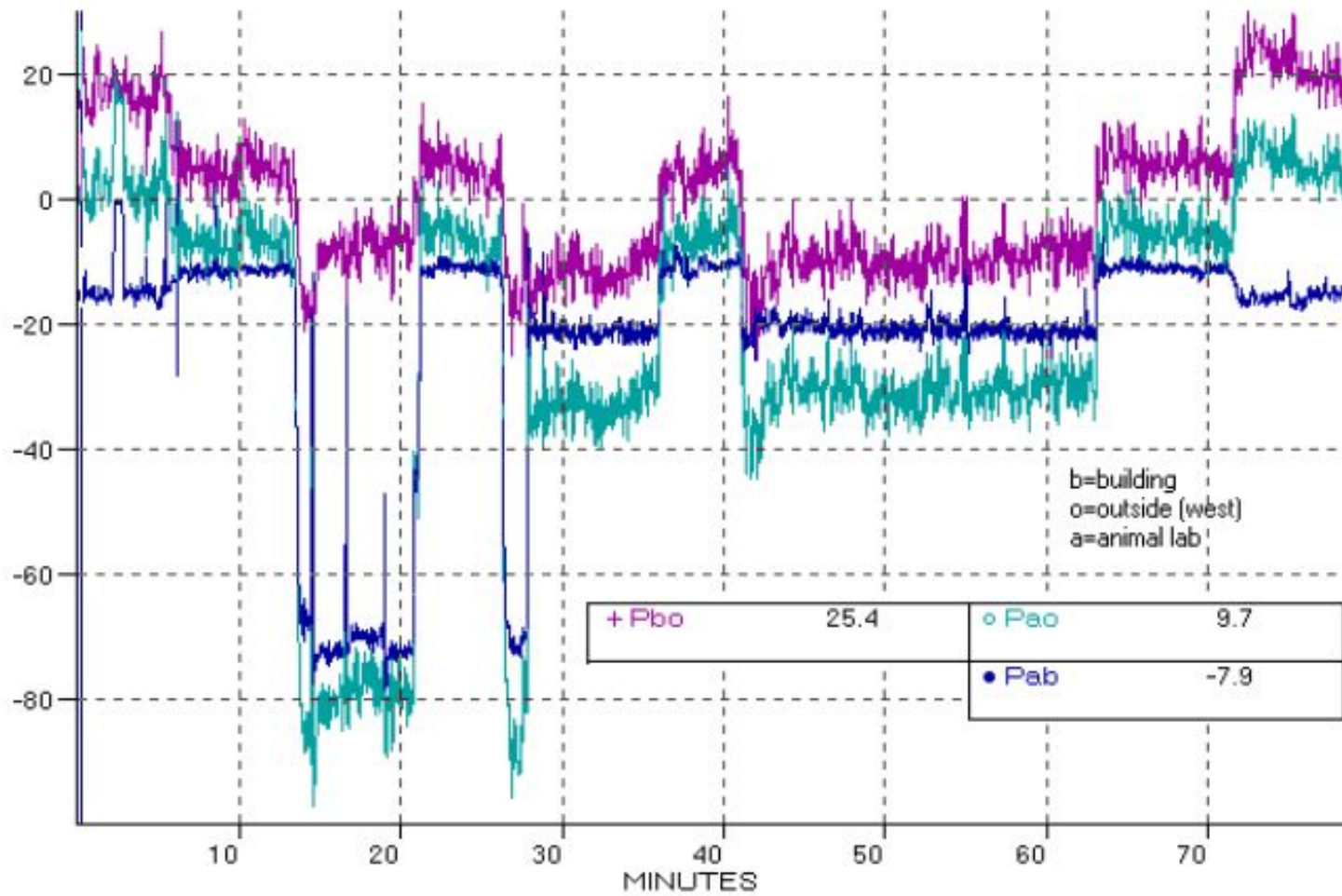

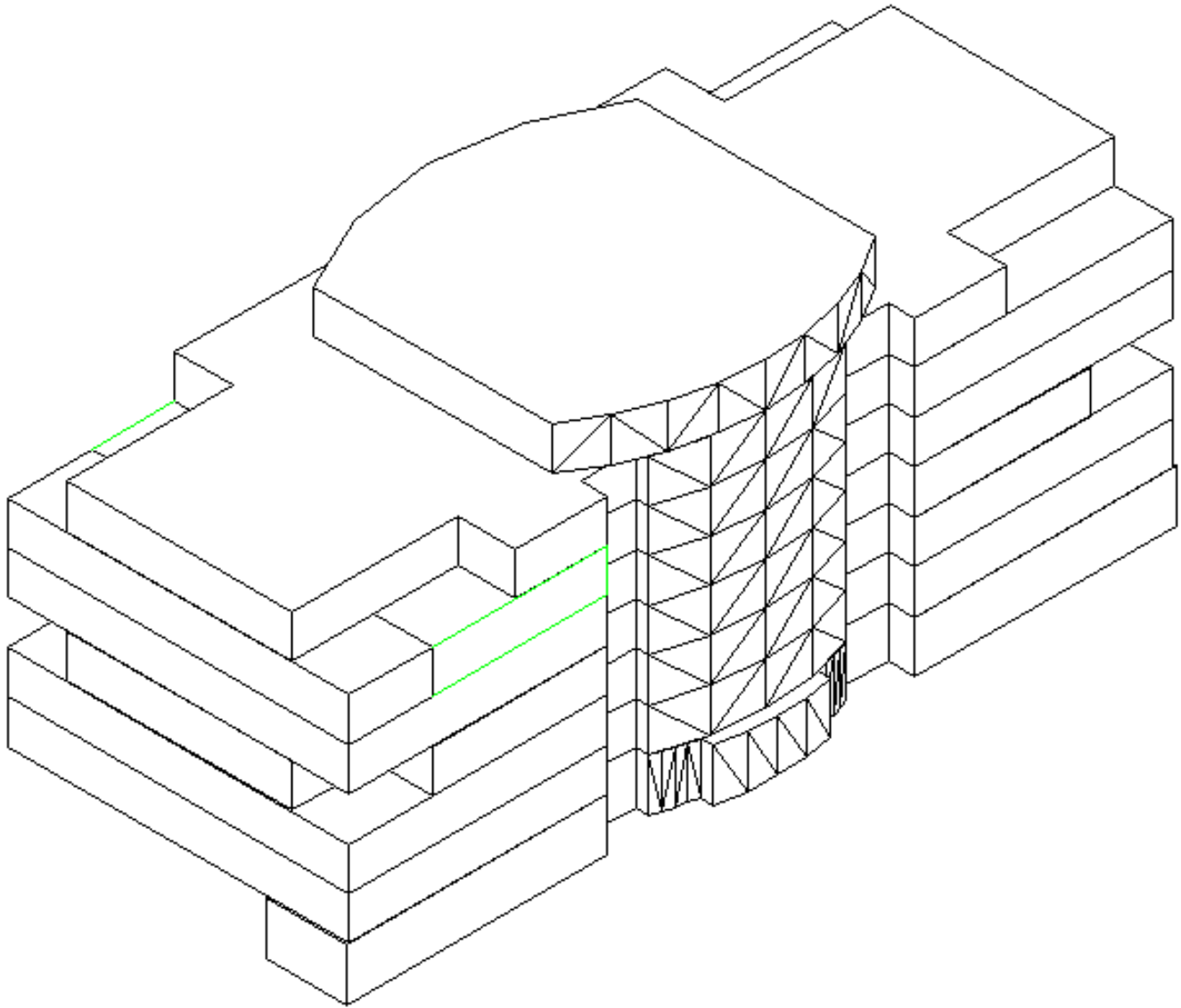

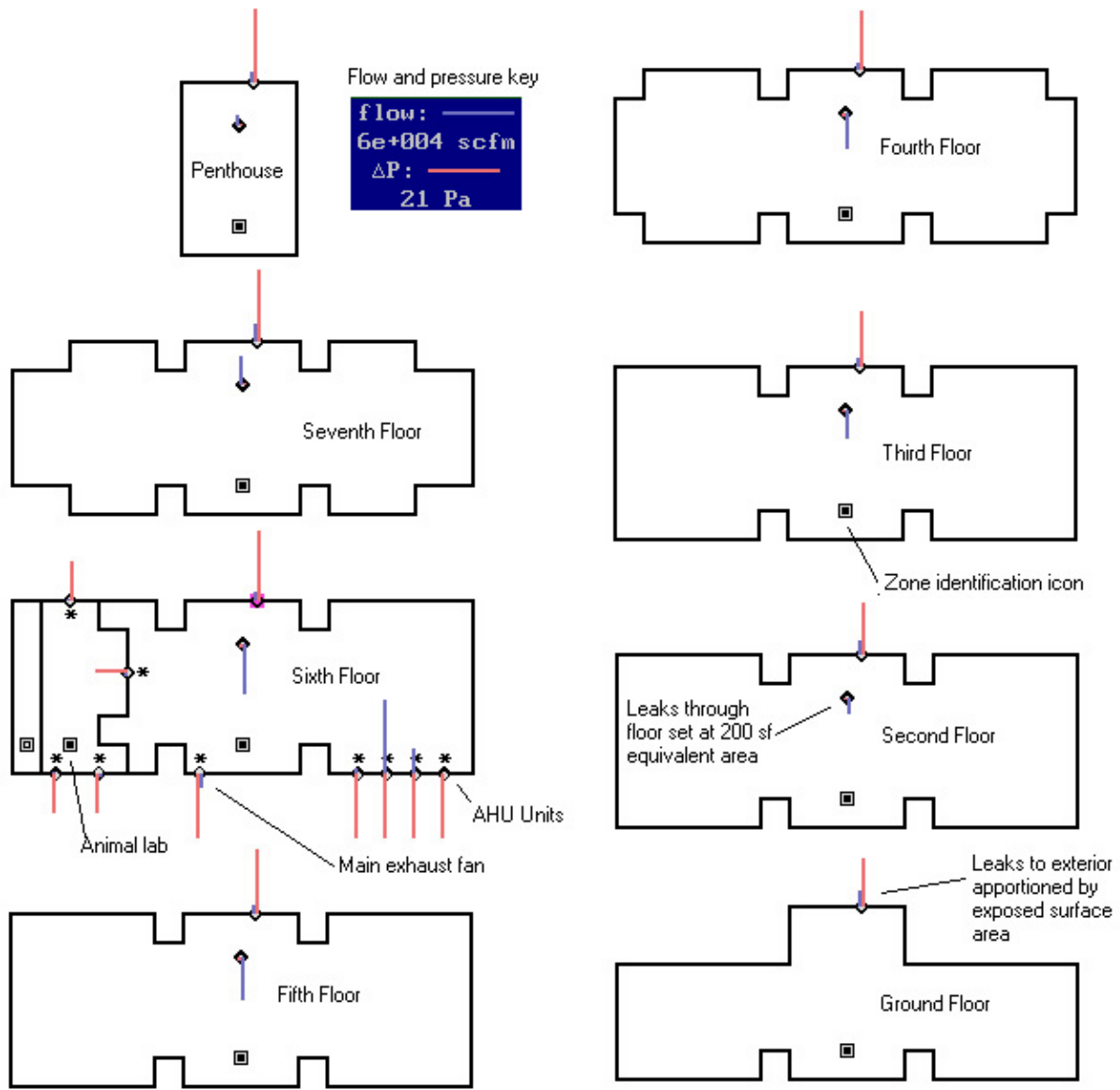

Air Barrier Metrics

Material	0.02 l/(s-m ²) @ 75 Pa
Assembly	0.20 l/(s-m ²) @ 75 Pa
Enclosure	2.00 l/(s-m ²) @ 75 Pa 0.25 cfm/ft ² @ 50 Pa

Getting rid of big holes	3 ach@50
Getting rid of smaller holes	1.5 ach@50
Getting German	0.6 ach@50













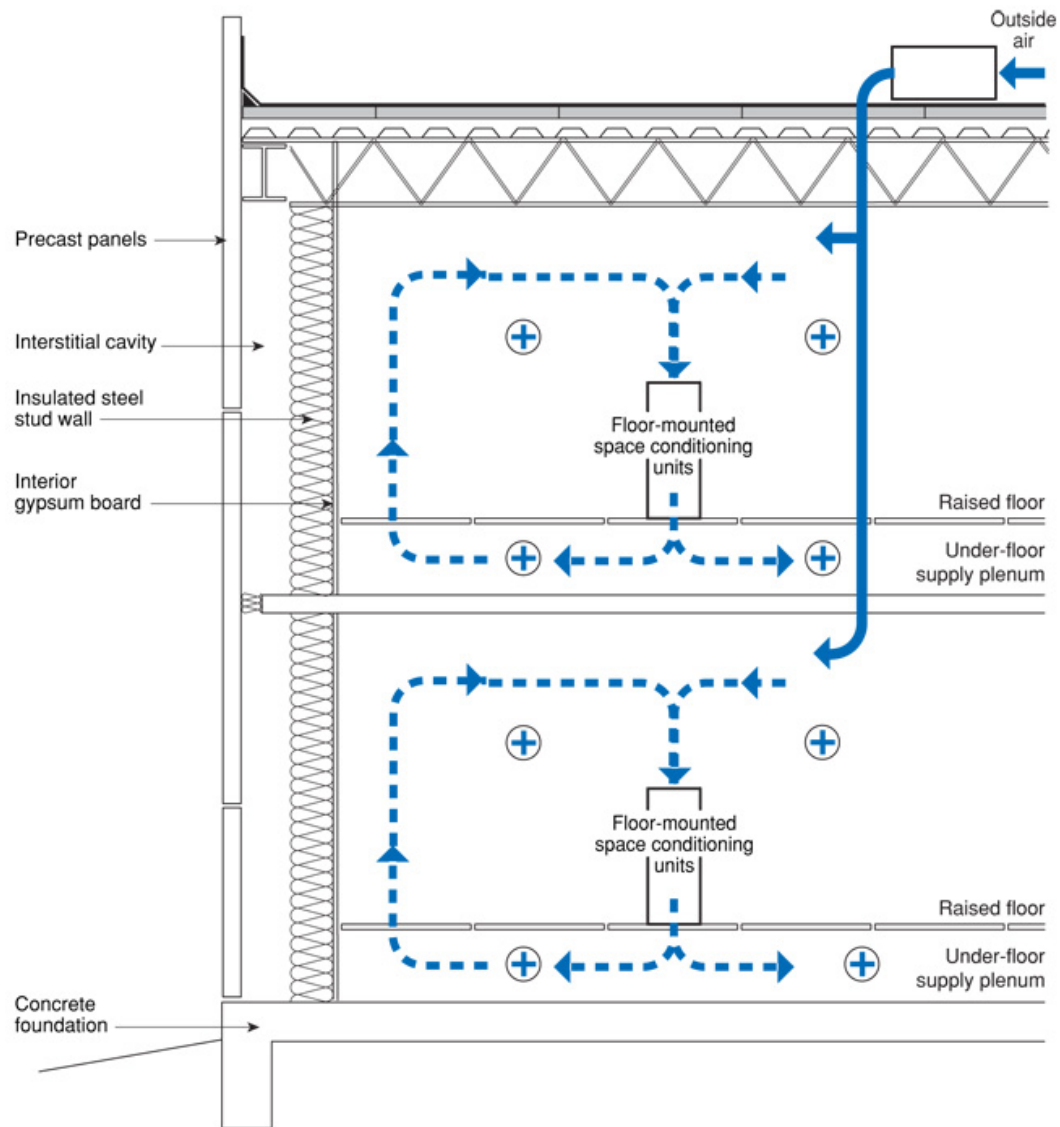

Figure 5.10
HVAC System as Designed

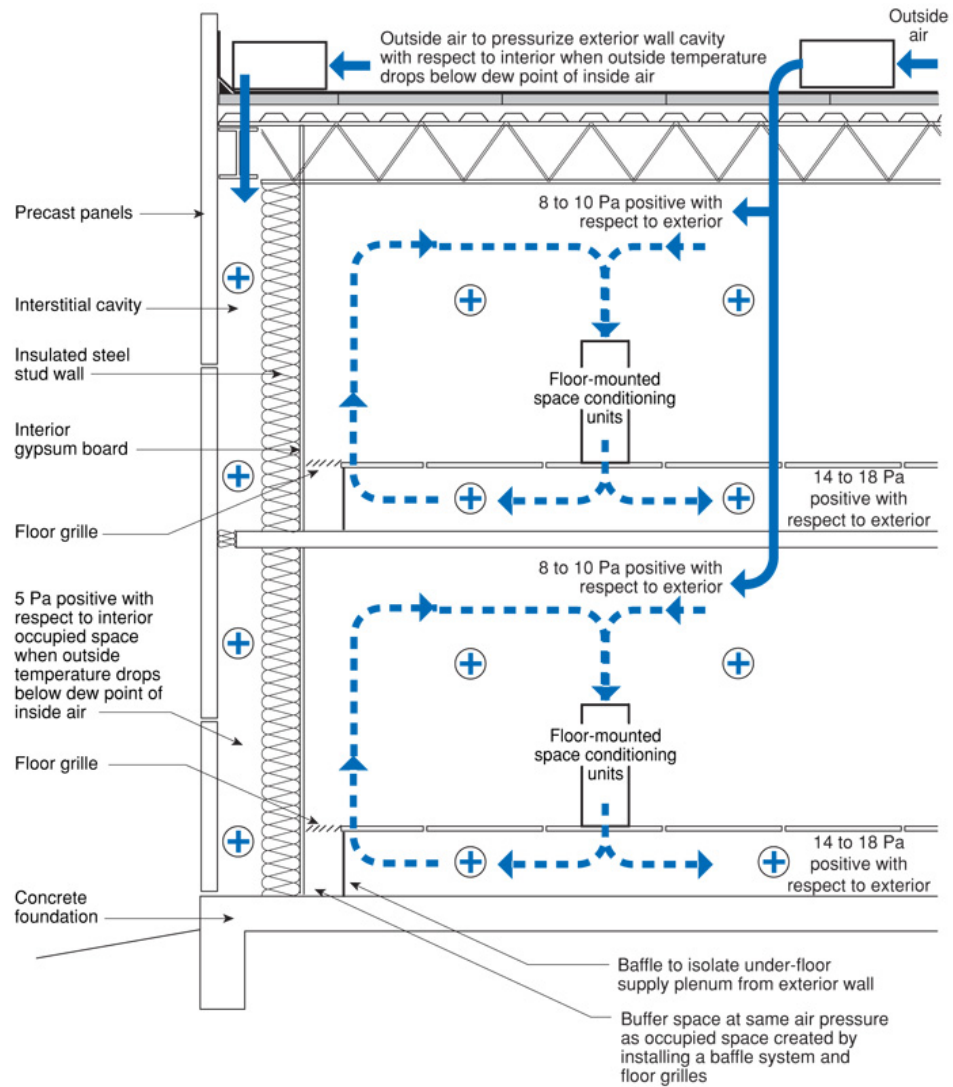

Figure 5.12
Modified Pressure Relationship



