

Joseph Lstiburek, Ph.D., P.Eng, ASHRAE Fellow

Building Science

Adventures In Building Science

presented by www.buildingscience.com

Definition of a Problem

People

Pollutant (hot, wet, UV, ozone)

Path

Pressure



Building Science

Joseph Lstiburek 3



Building Science

Joseph Lstiburek 4



Building Science

Joseph Lstiburek 5



Building Science

Joseph Lstiburek 6

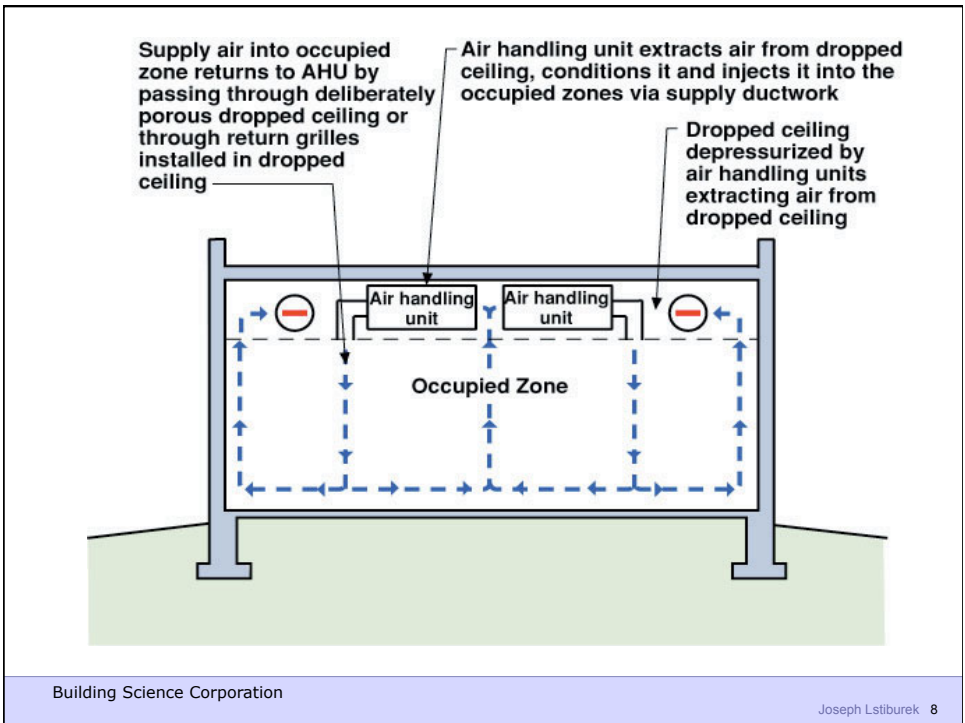
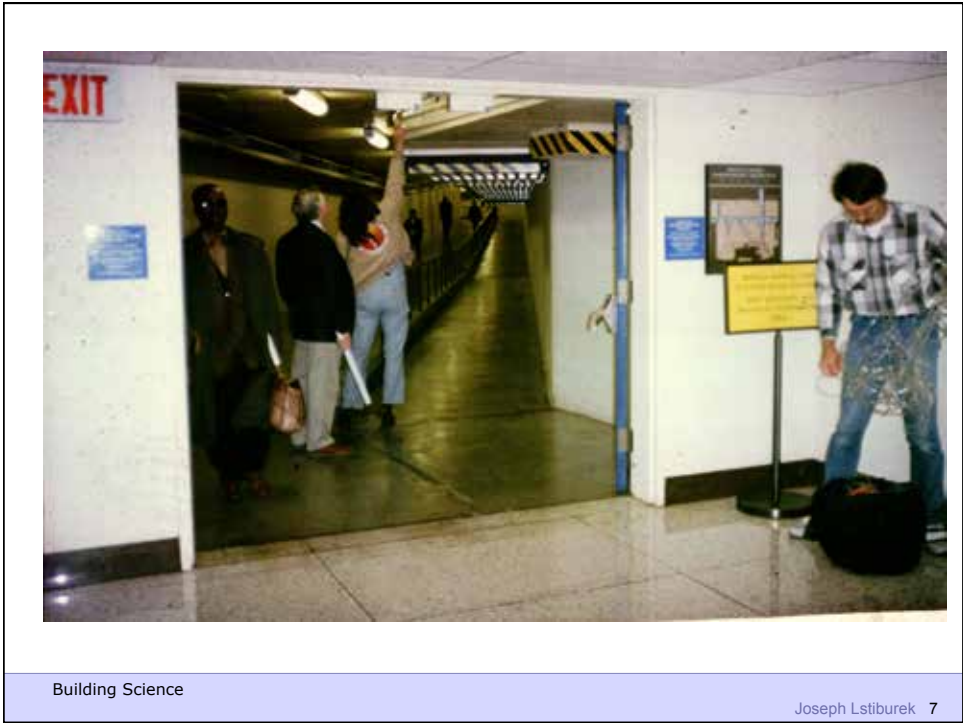

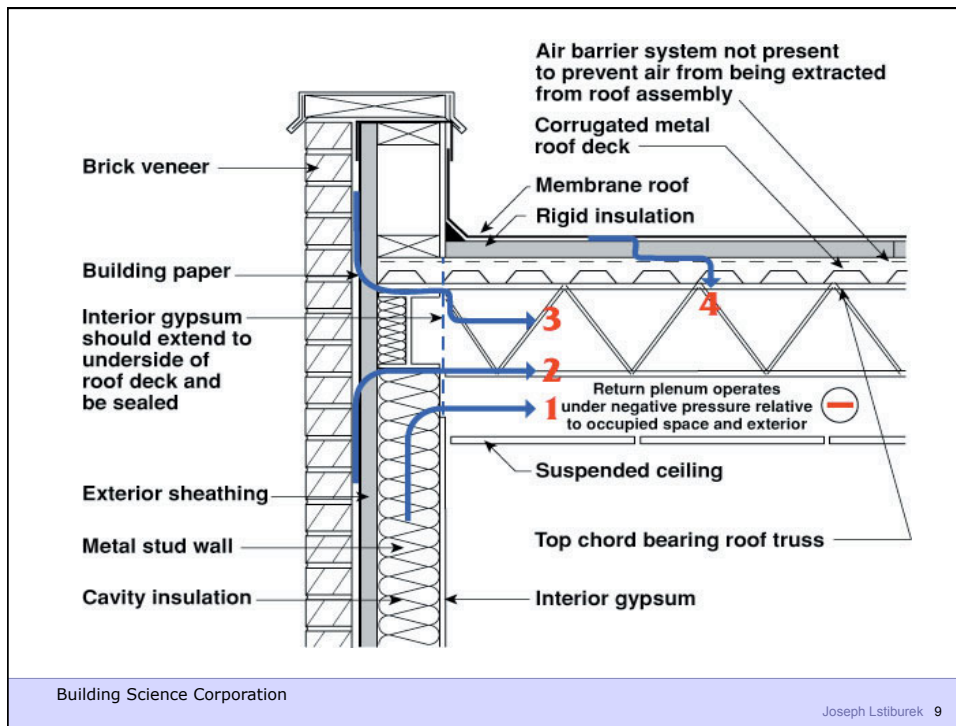



Building Science Corporation

Joseph Lstiburek 11



Building Science Corporation

Joseph Lstiburek 12

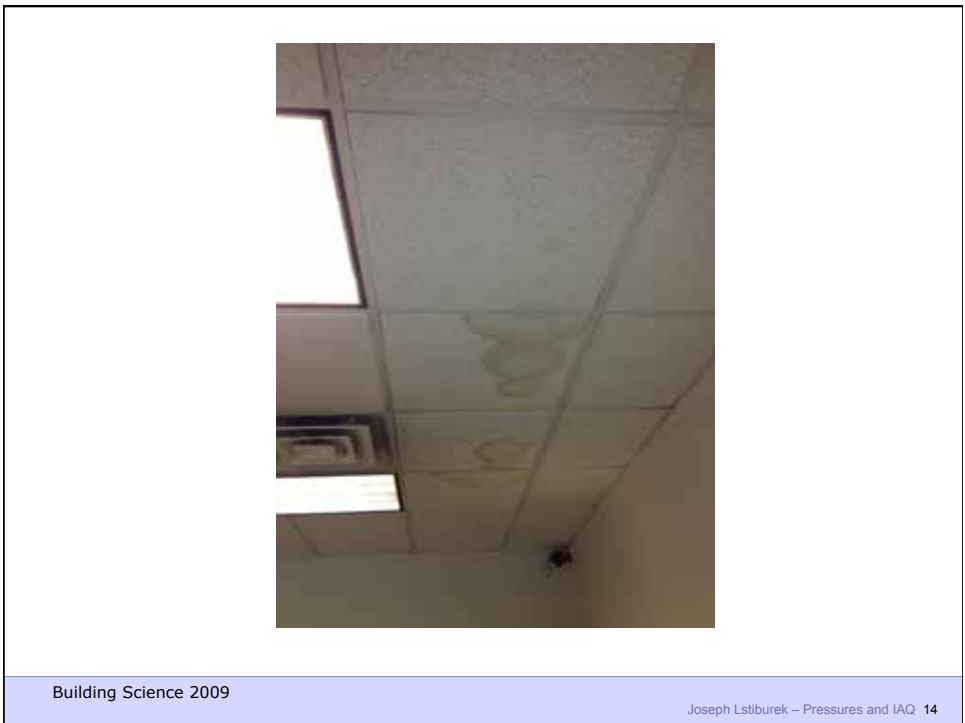



Building Science Corporation

Joseph Lstiburek 15



Building Science Corporation

Joseph Lstiburek 16

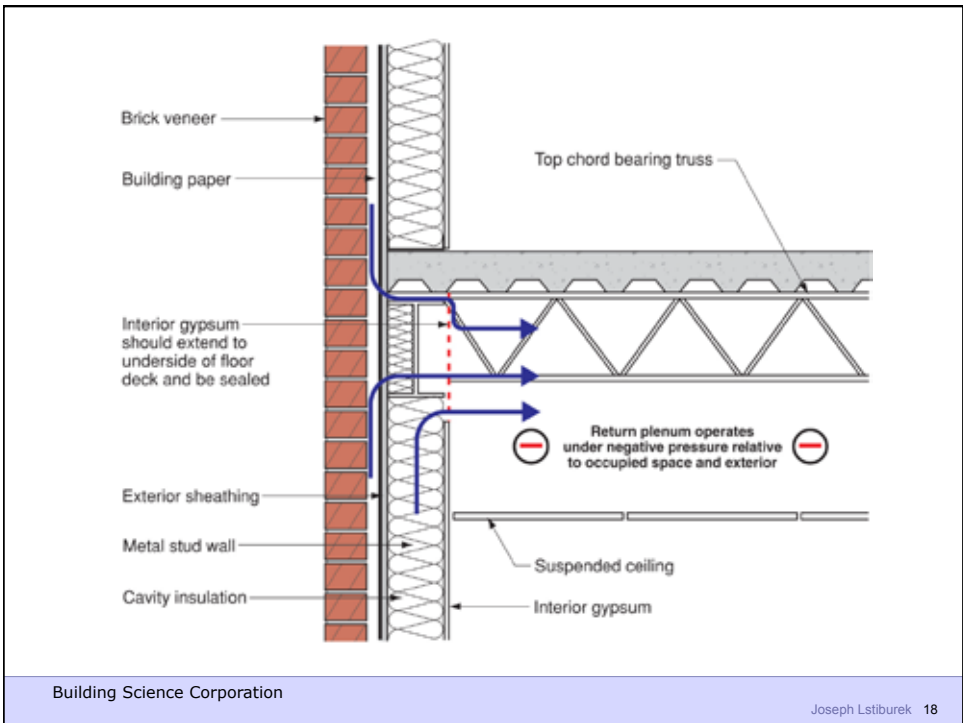
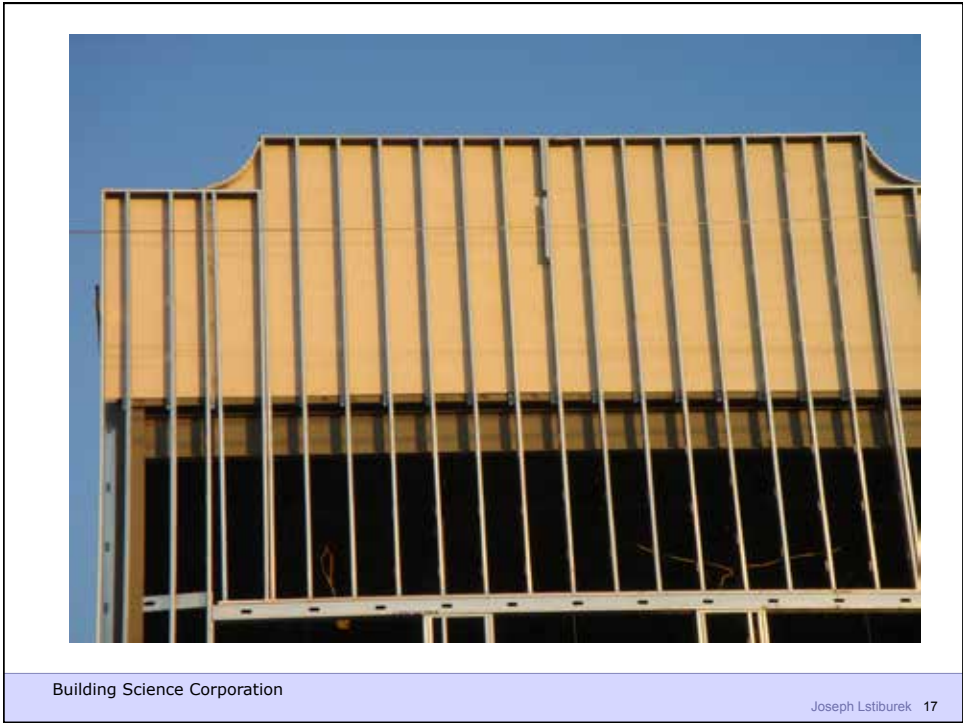

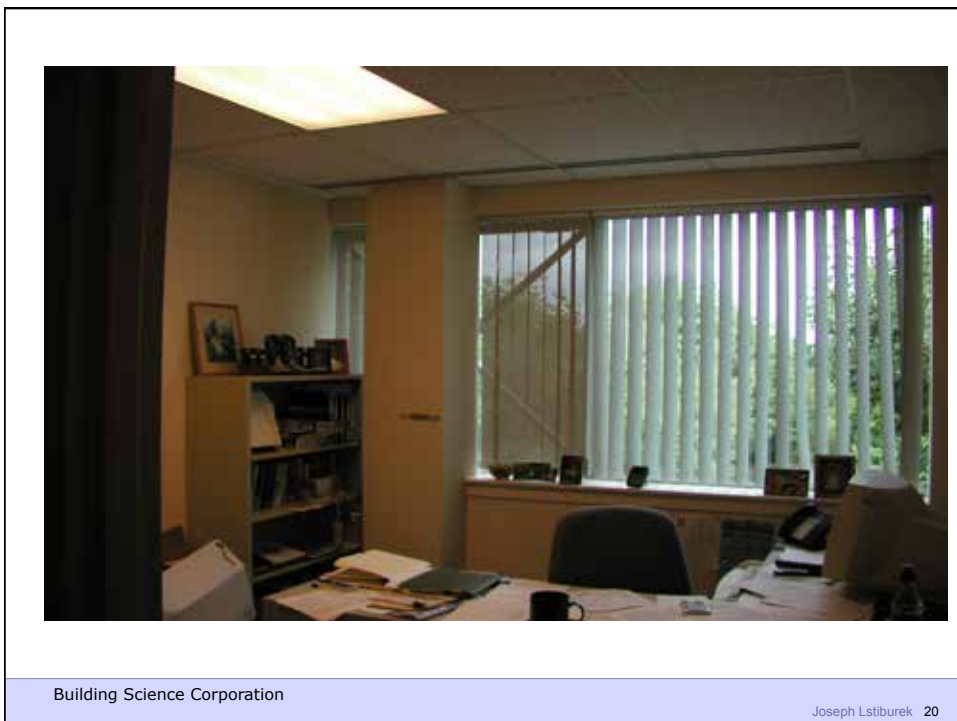



Building Science Corporation

Joseph Lstiburek 21



Building Science Corporation

Joseph Lstiburek 22



Building Science Corporation

Joseph Lstiburek 23



Building Science Corporation

Joseph Lstiburek 24



Building Science Corporation

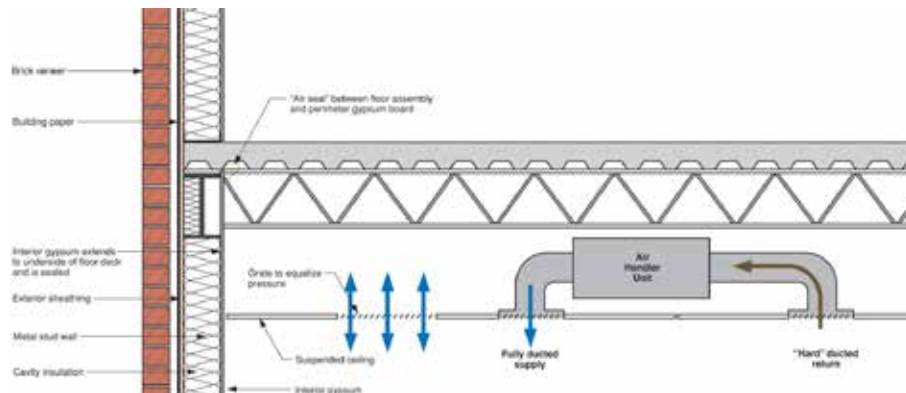

Building Science Corporation

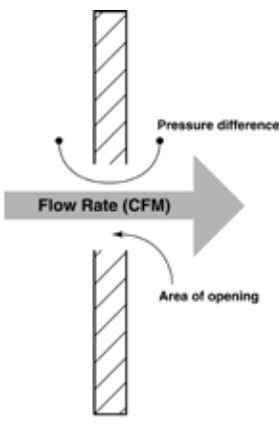

Air Flow

- Air flow depends on size of hole
- Air flow depends on pressure difference
 $Flow = Area \times \sqrt{\Delta P} \times Coefficient$
- Air flows from higher pressure to lower pressure

Building Science Corporation Joseph Lstiburek 27



Figure 2.11
Three Dimensional Multi-Layer
Multi-Cell Analogue

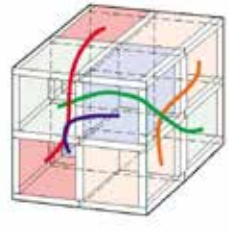
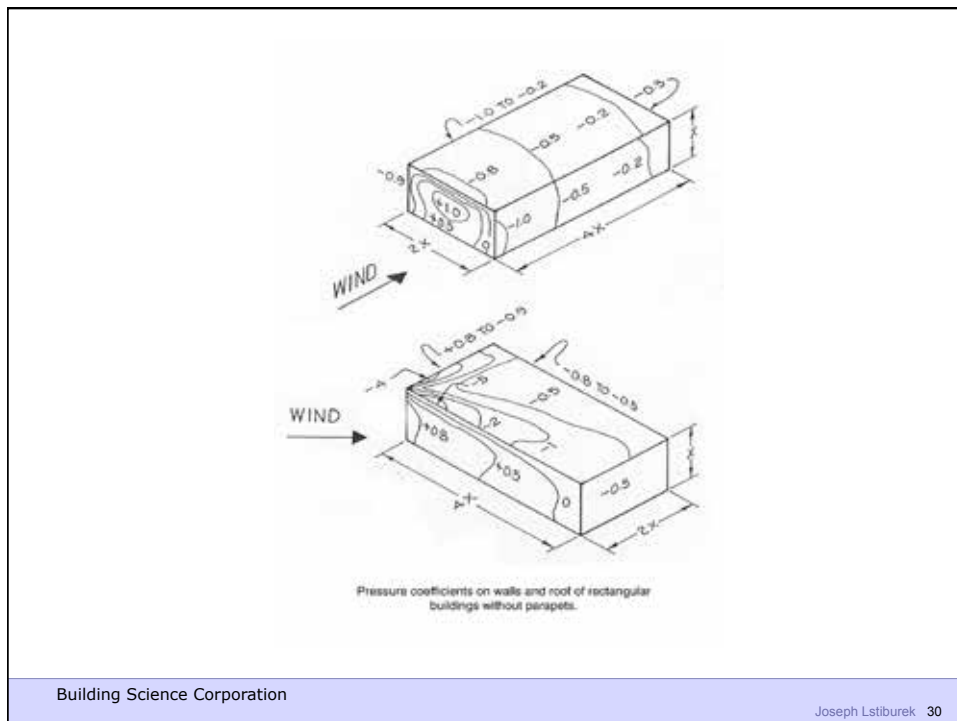
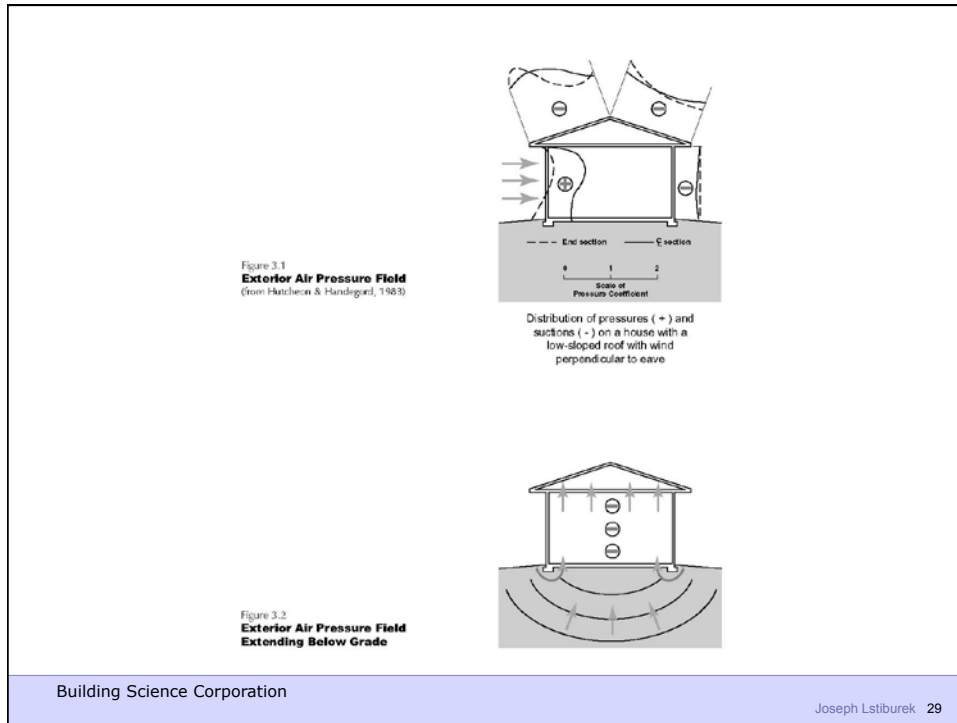

Figure 2.12
Three Dimensional Multi-Layer
Multi-Cell Non-Contiguous
Analogue

Building Science Corporation Joseph Lstiburek 28



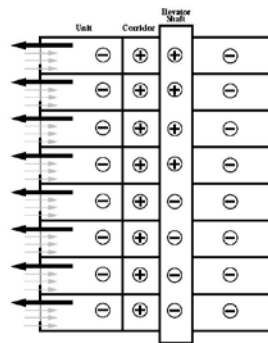

Figure 3.3
Interior Air Pressure Field

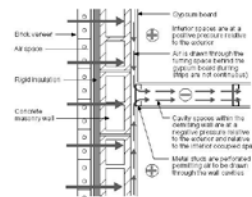

Figure 3.4
Interstitial Air Pressure Field

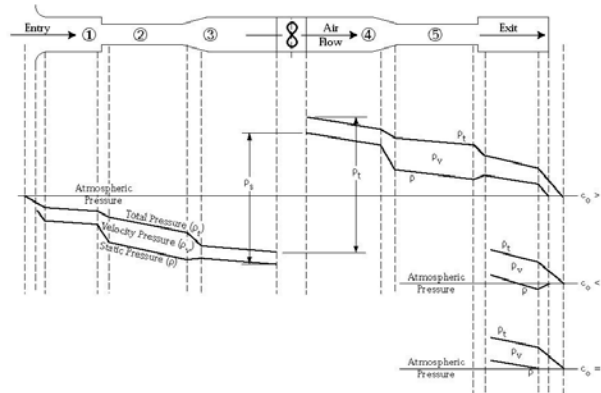
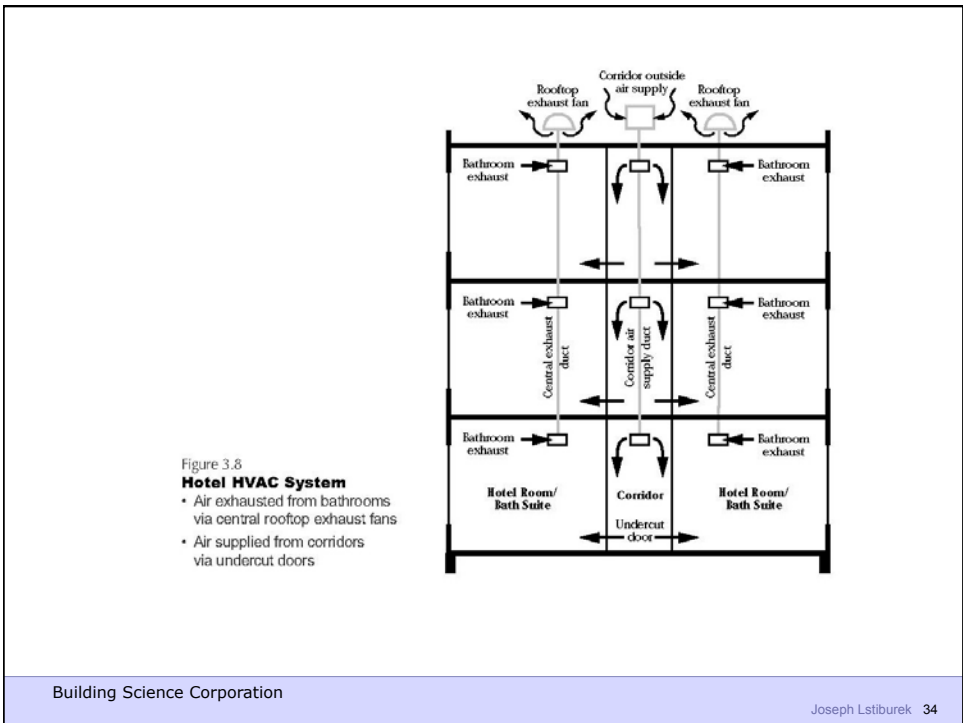
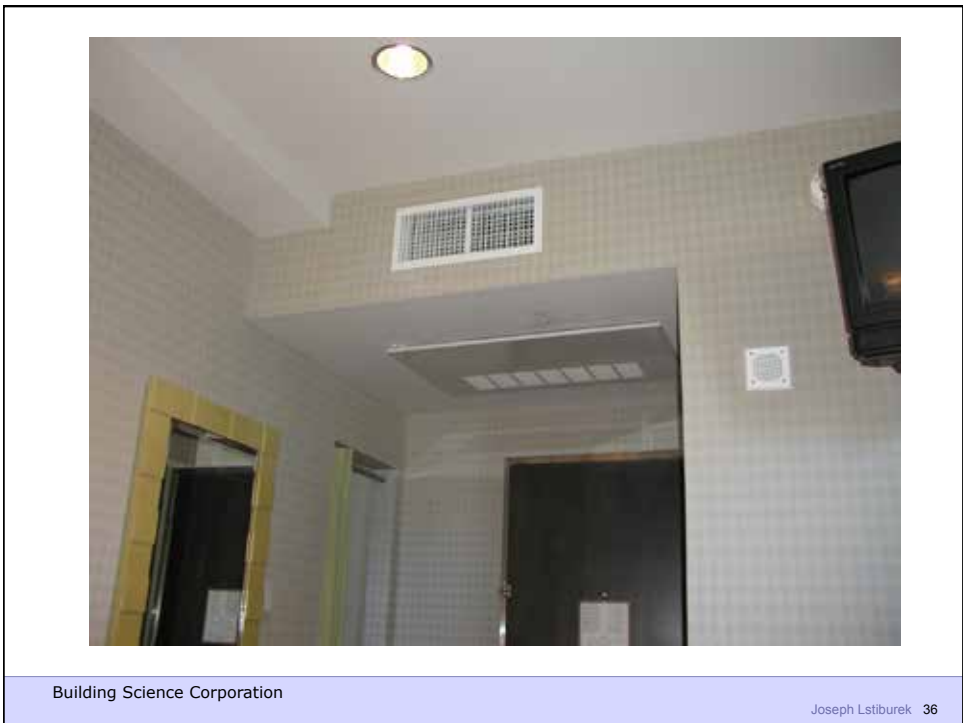
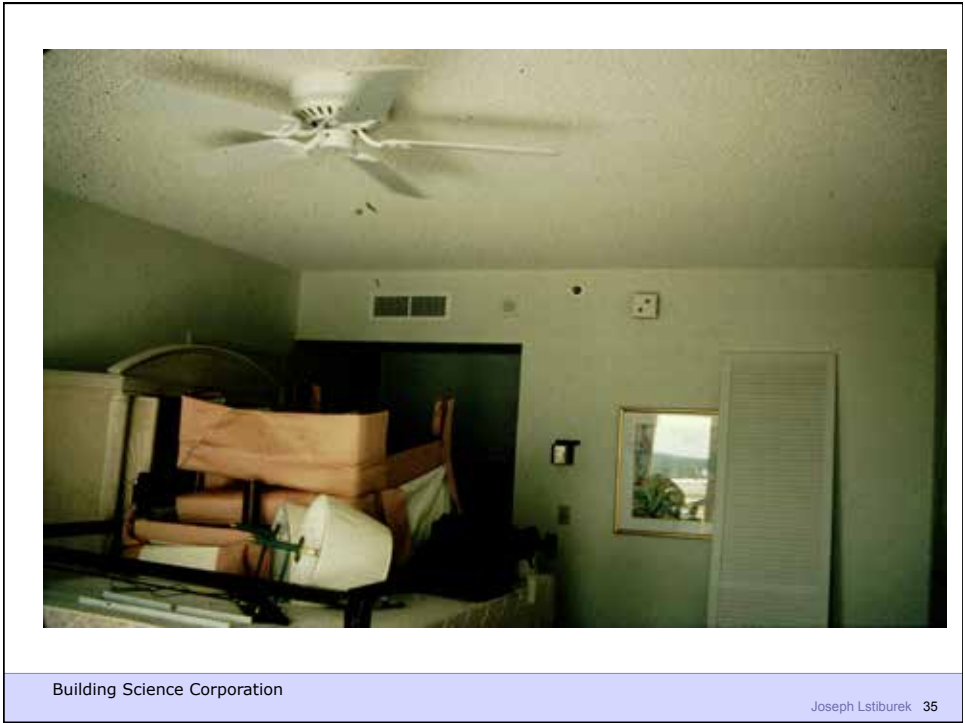
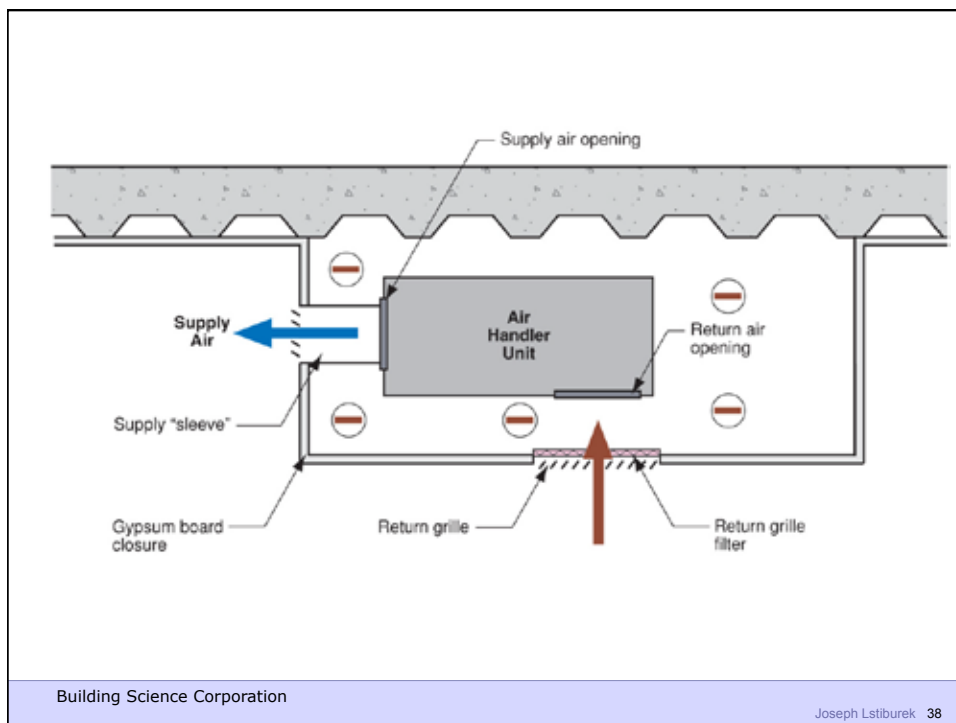
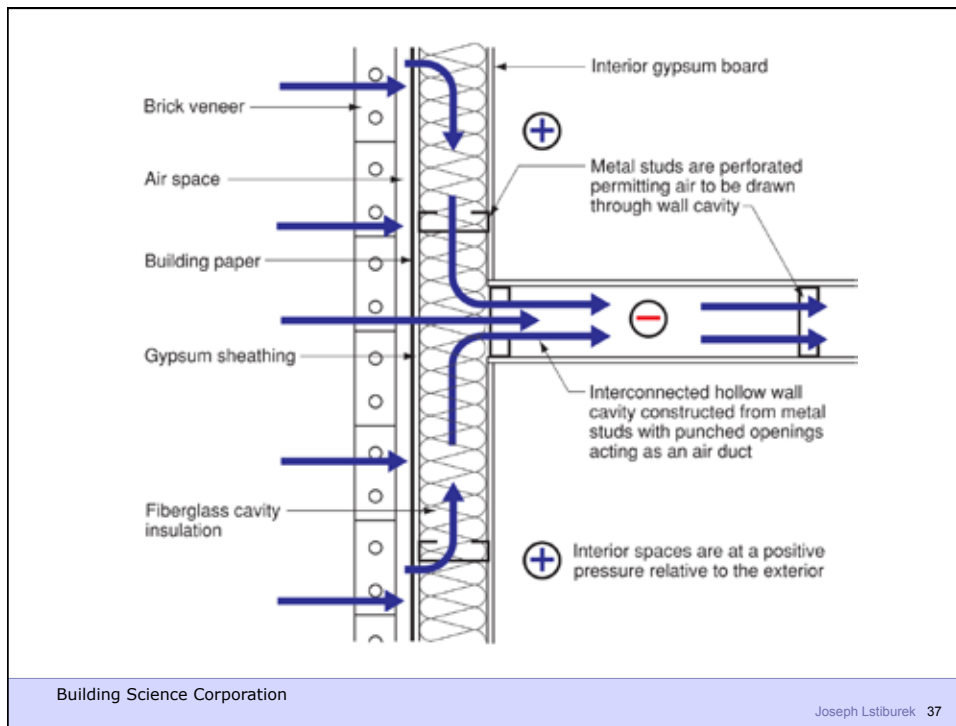
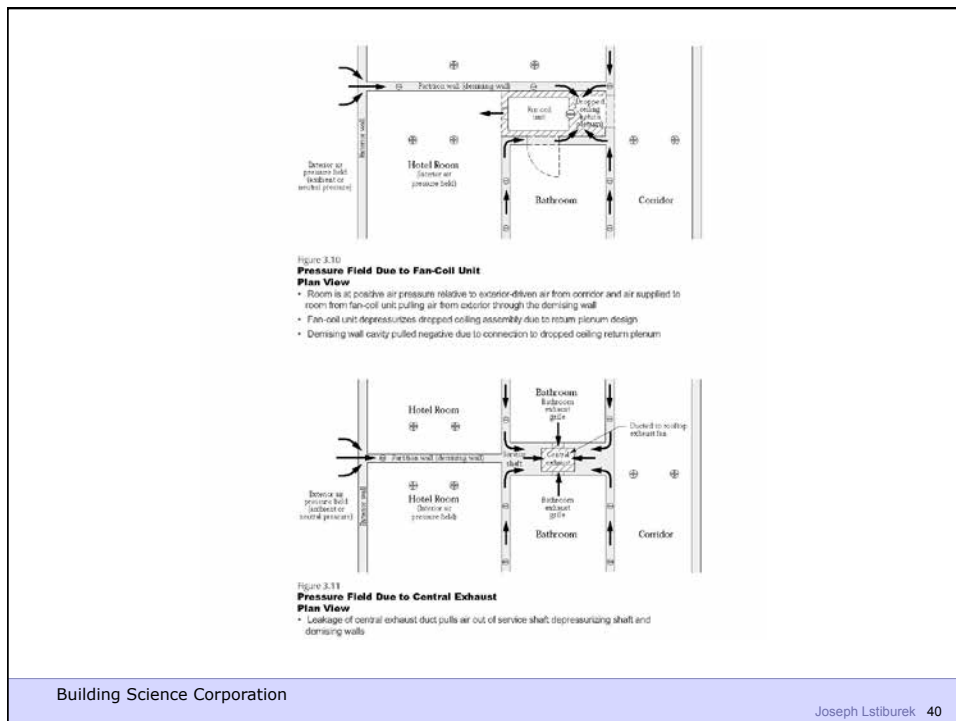
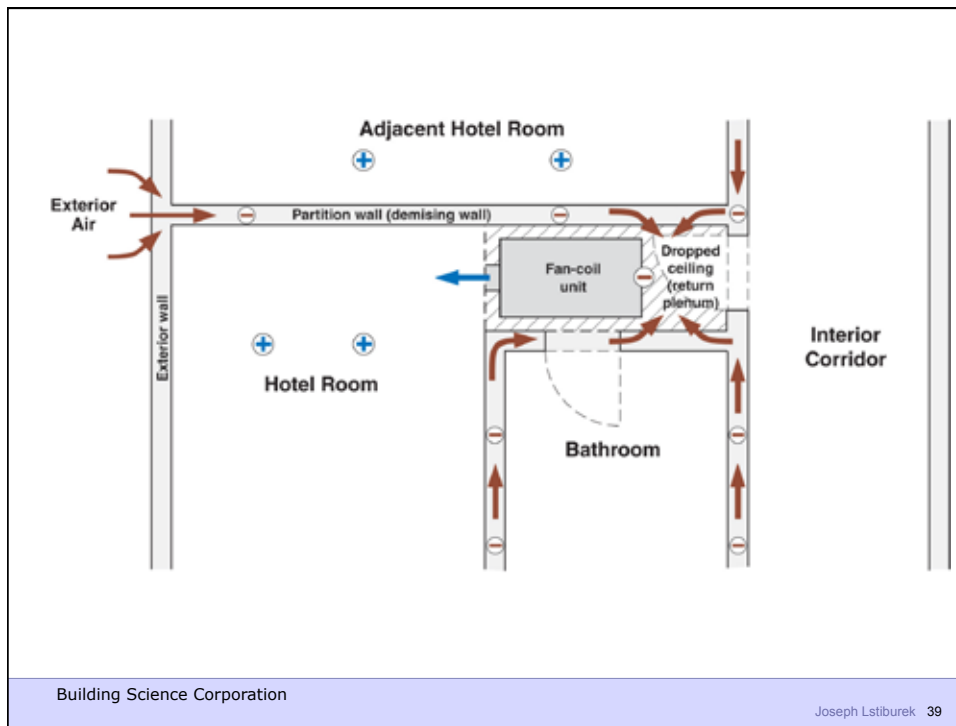

Figure 3.5
Air Conveyance System Air Pressure Field
(from Sauer & Howell, 1990)











Building Science Corporation

Joseph Lstiburek 41



Building Science Corporation

Joseph Lstiburek 42



Building Science Corporation

Joseph Lstiburek 43



Building Science Corporation

Joseph Lstiburek 44

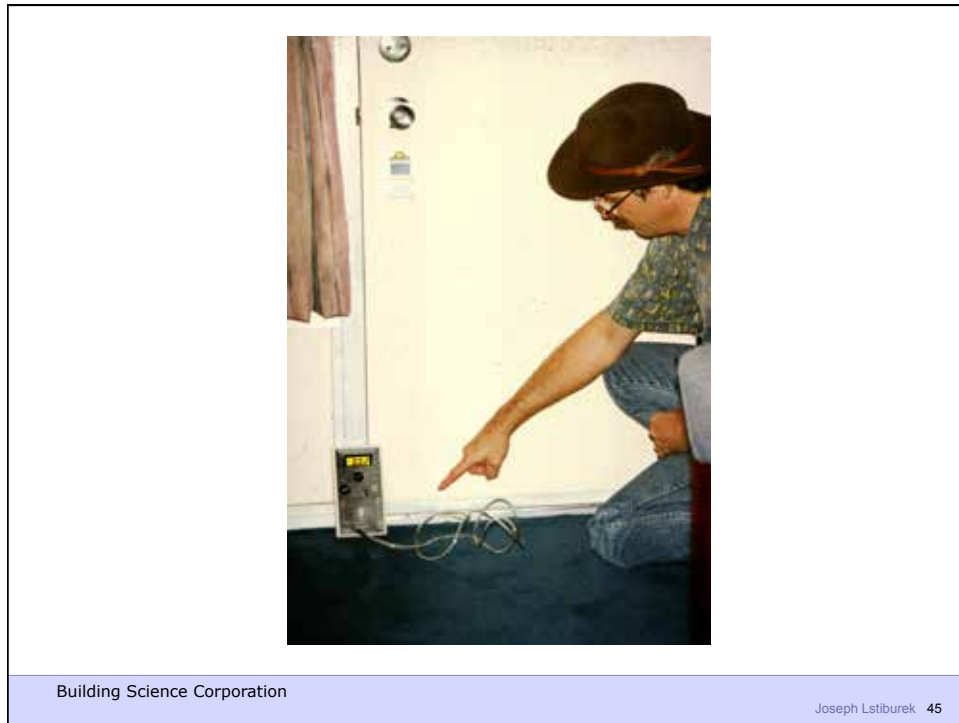





Building Science Corporation

Joseph Lstiburek 49



Building Science Corporation

Joseph Lstiburek 50



Building Science Corporation

Joseph Lstiburek 51

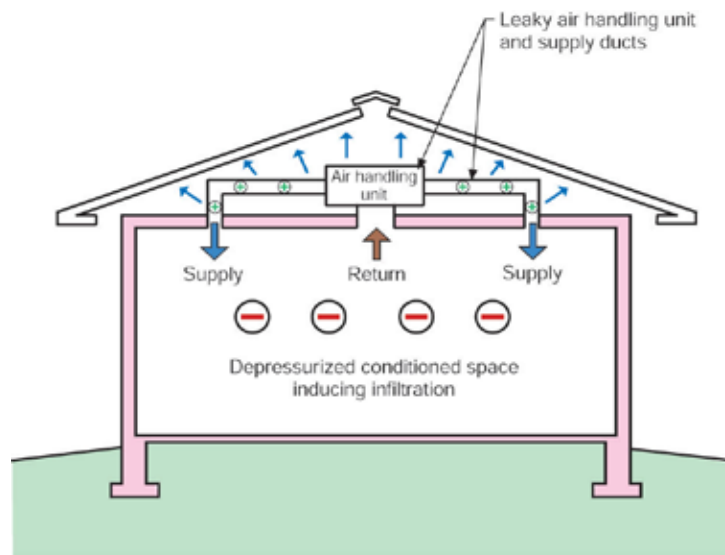

Note: Colored shading depicts the building's thermal barrier and pressure boundary. The thermal barrier and pressure boundary enclose the conditioned space.

Building Science Corporation

Joseph Lstiburek 52

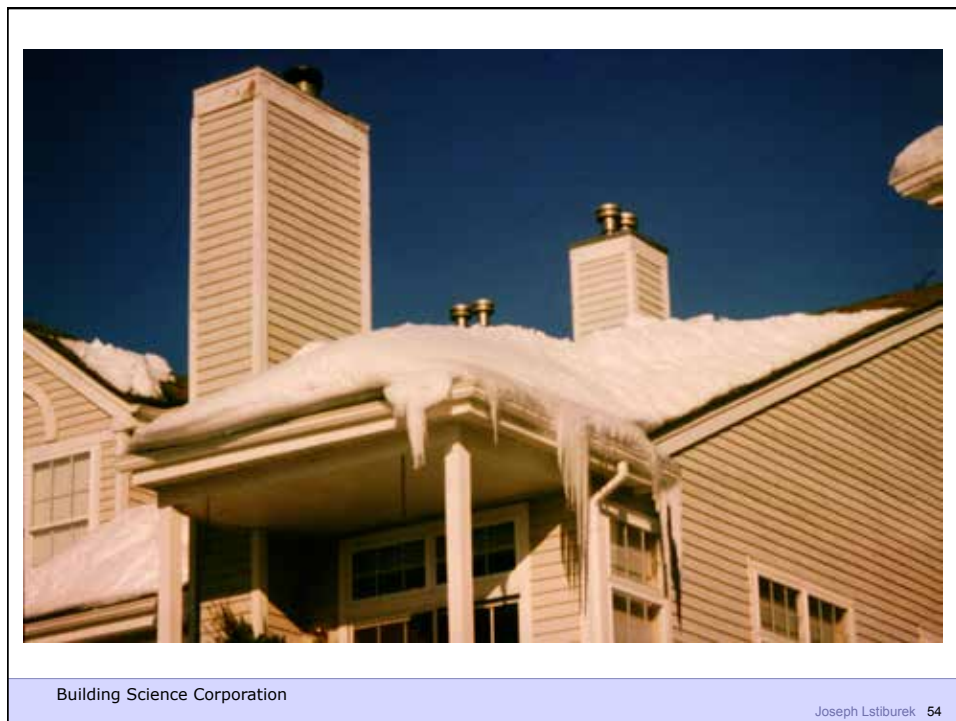
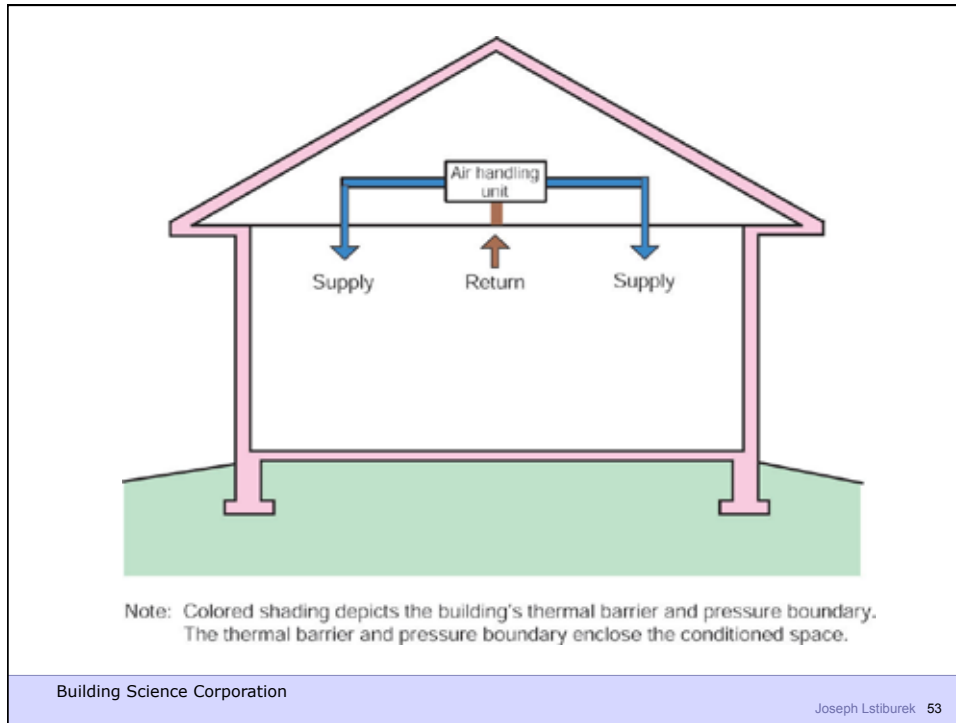



Building Science Corporation

Joseph Lstiburek 55



Building Science Corporation

Joseph Lstiburek 56

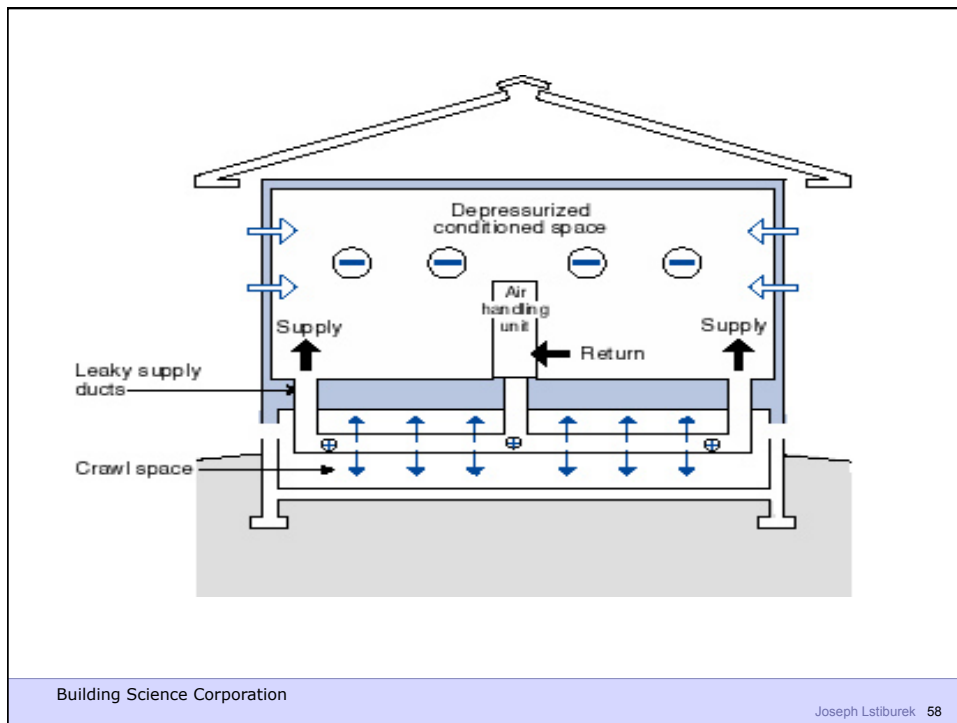
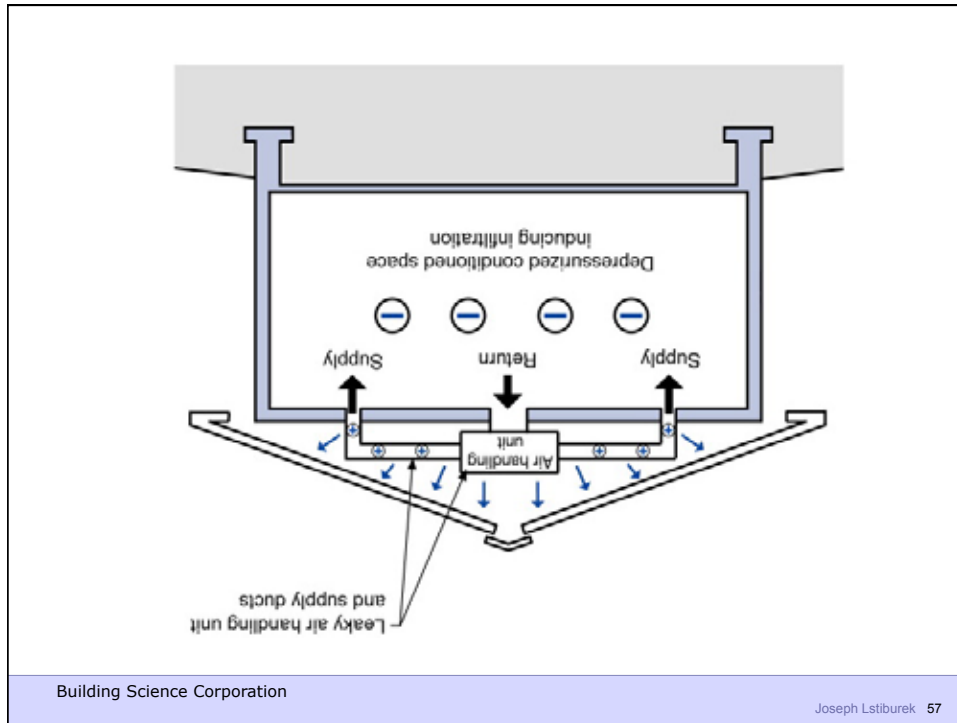



Building Science Corporation

Joseph Lstiburek 59



Building Science Corporation

Joseph Lstiburek 60



Building Science Corporation

Joseph Lstiburek 61



Building Science Corporation

Joseph Lstiburek 62

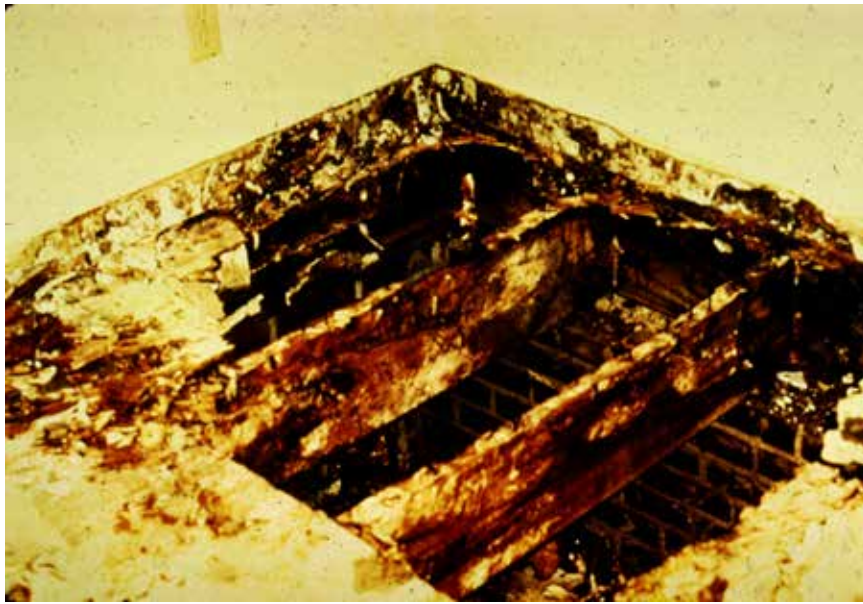

Building Science Corporation

Joseph Lstiburek 63



Building Science Corporation

Joseph Lstiburek 64



Building Science Corporation

Joseph Lstiburek 65



Building Science Corporation

Joseph Lstiburek 66

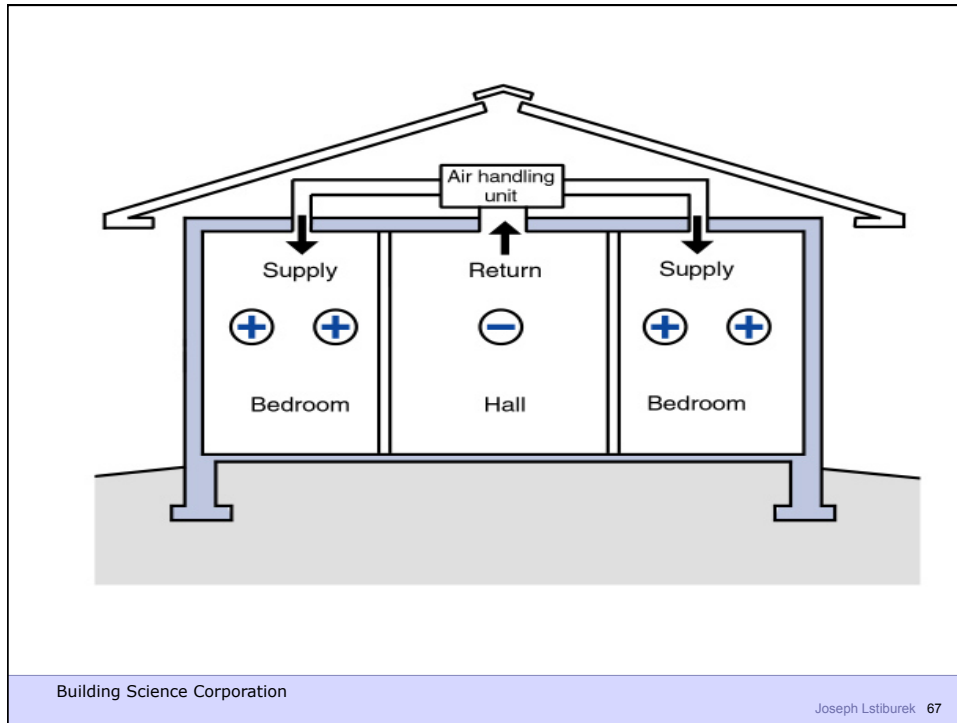



Building Science Corporation

Joseph Lstiburek 71



Building Science Corporation

Joseph Lstiburek 72



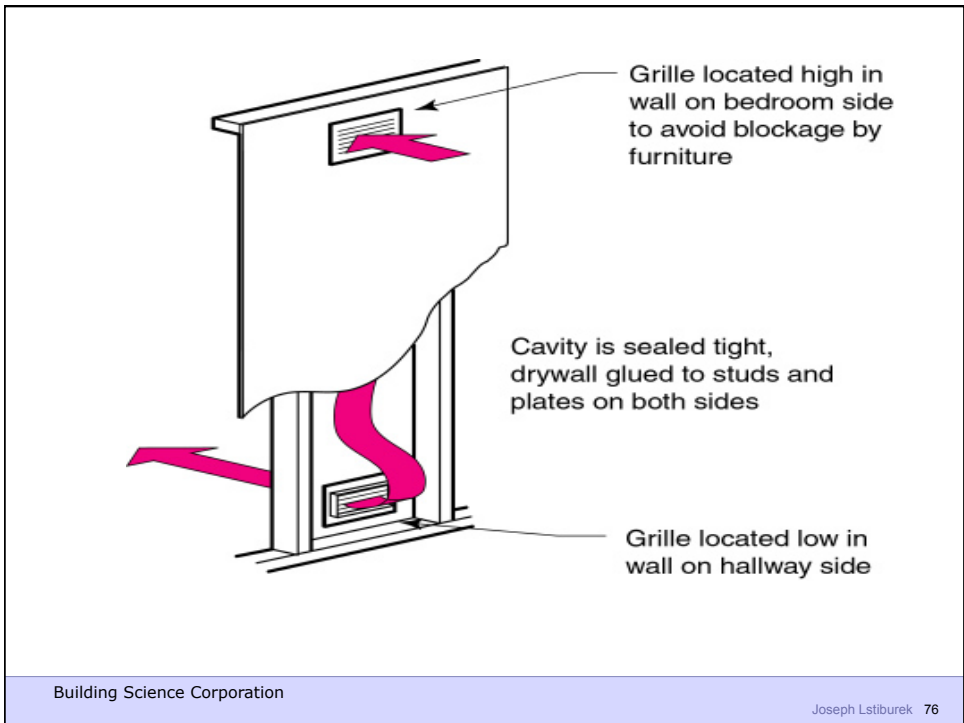

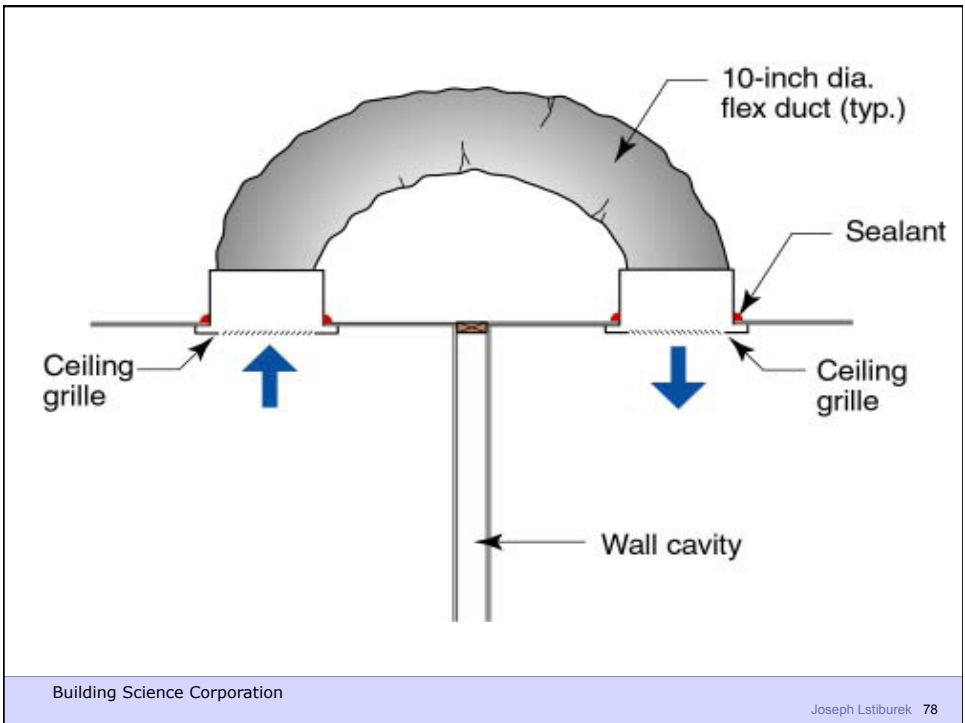

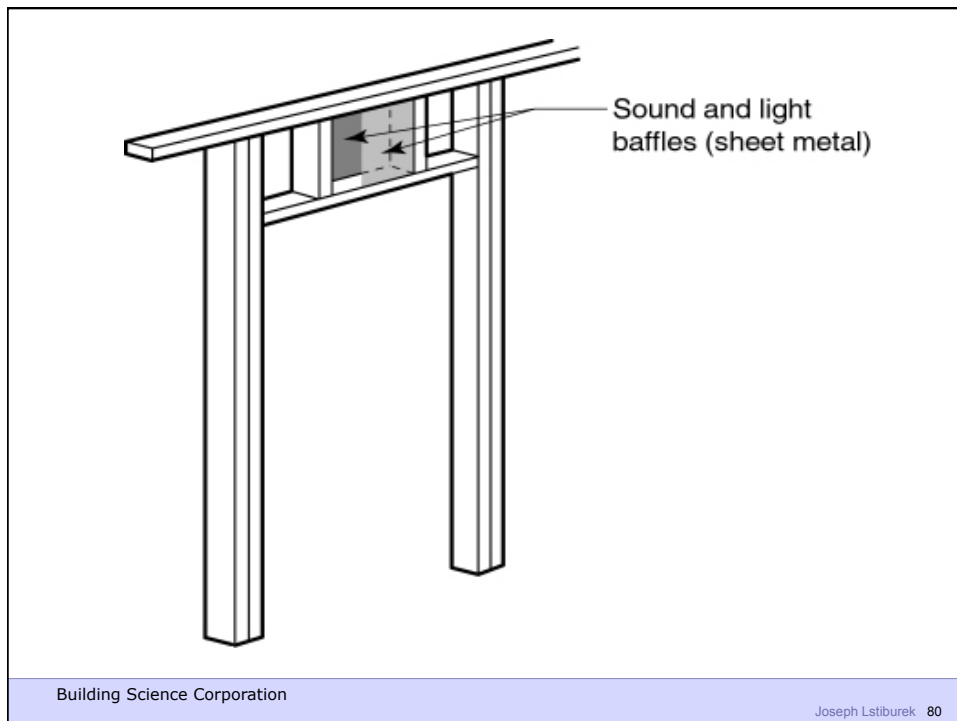
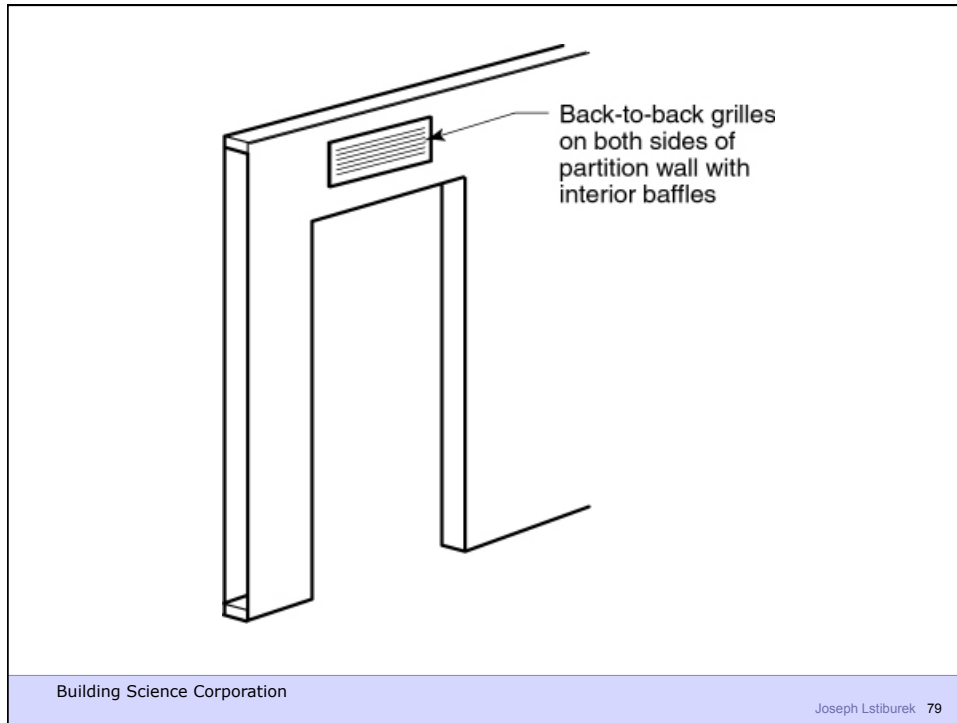

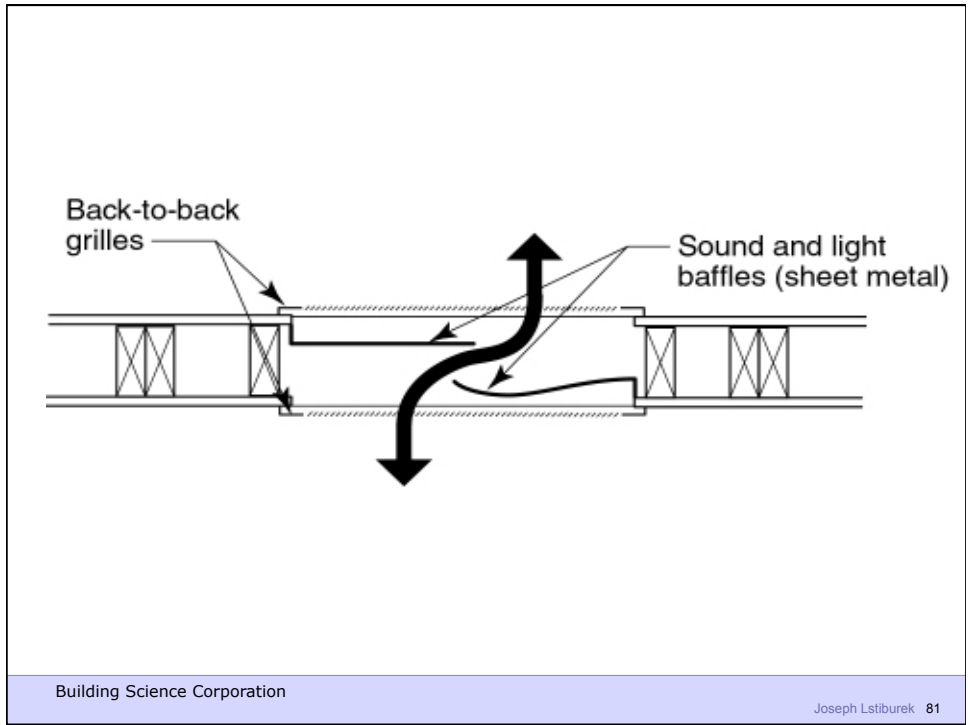



Building Science Corporation

Joseph Lstiburek 83



Building Science Corporation

Joseph Lstiburek 84



Building Science Corporation

Joseph Lstiburek 85



Building Science Corporation

Joseph Lstiburek 86



Building Science Corporation

Joseph Lstiburek 87



Building Science Corporation

Joseph Lstiburek 88

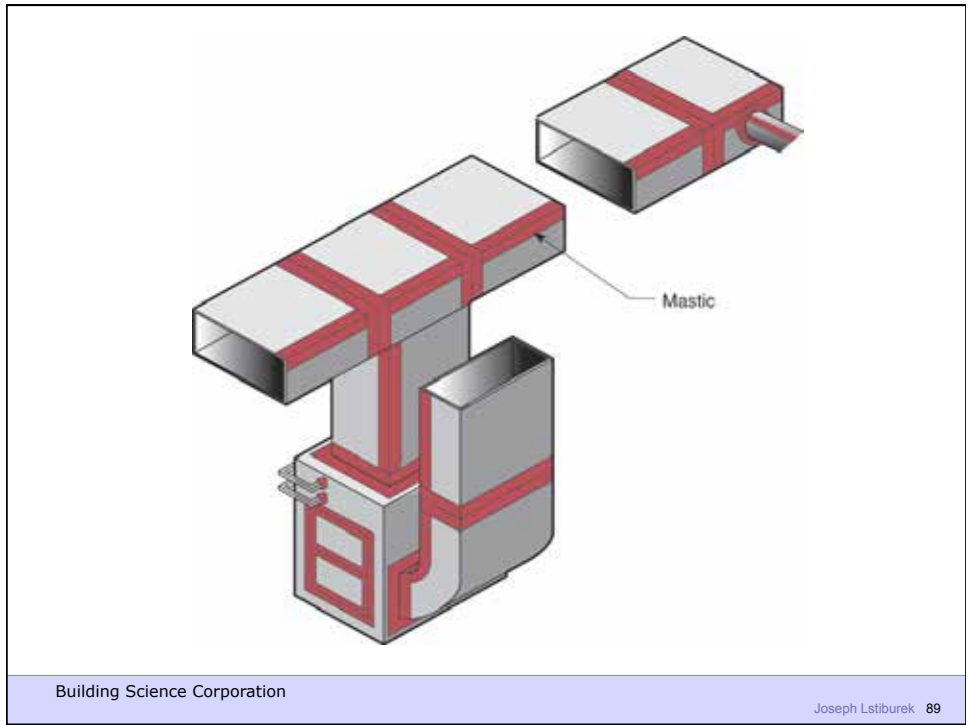



Building Science Corporation

Joseph Lstiburek 91