

Joseph Lstiburek, Ph.D., P.Eng, ASHRAE Fellow

Building Science

Adventures In Building Science

www.buildingscience.com

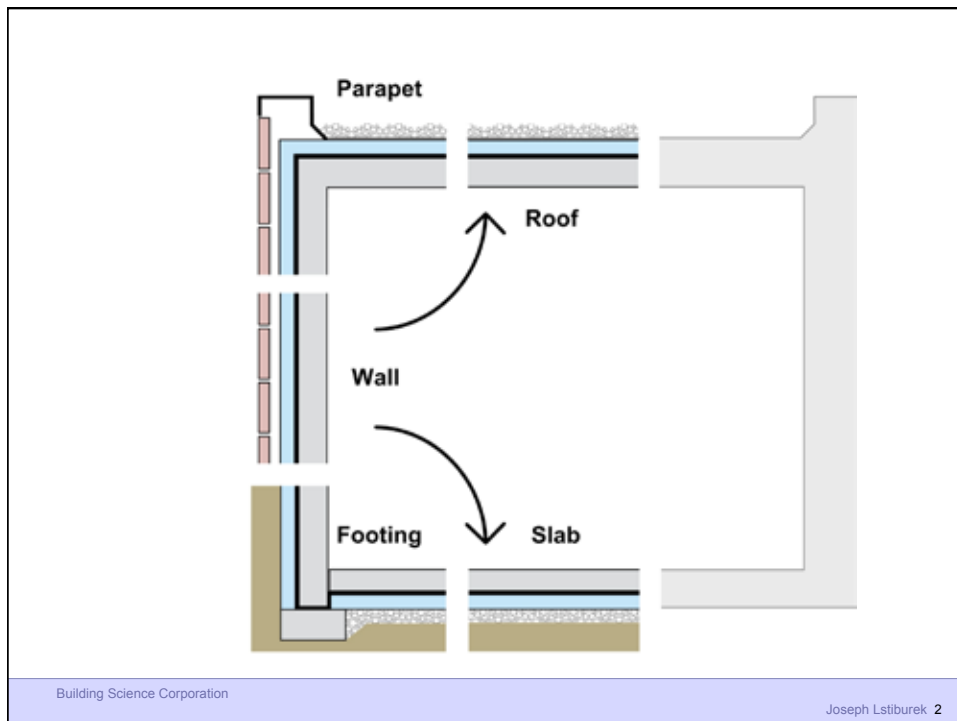

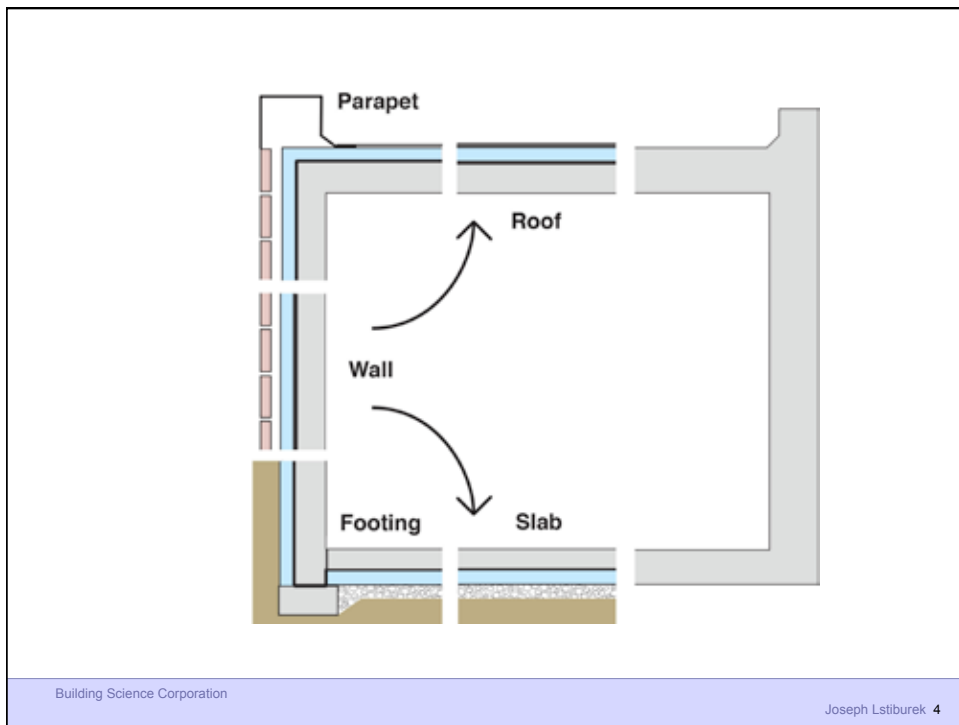
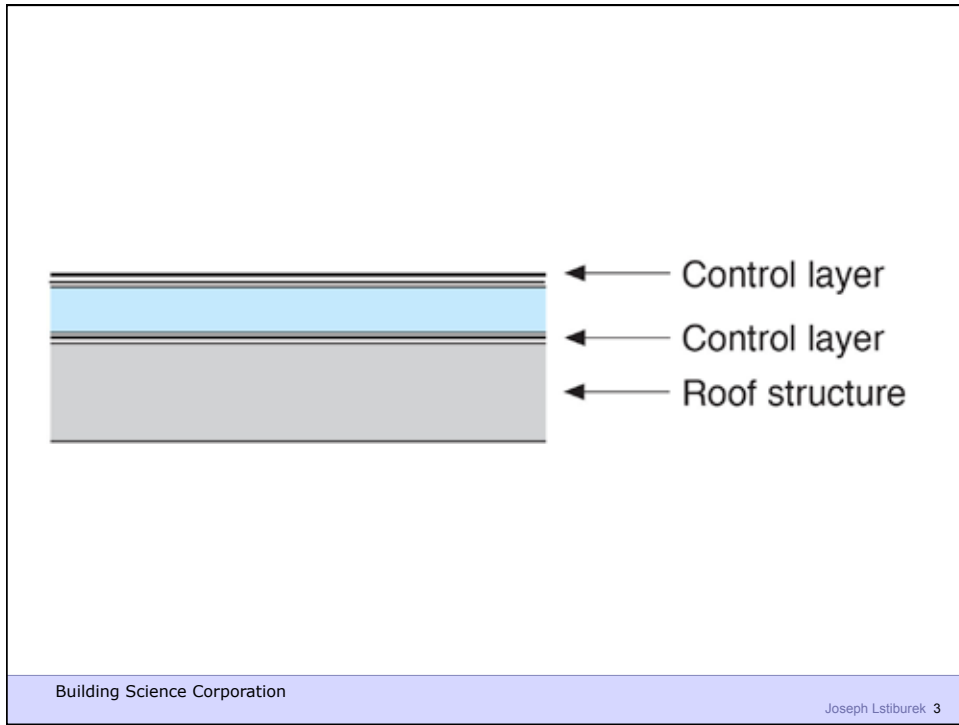

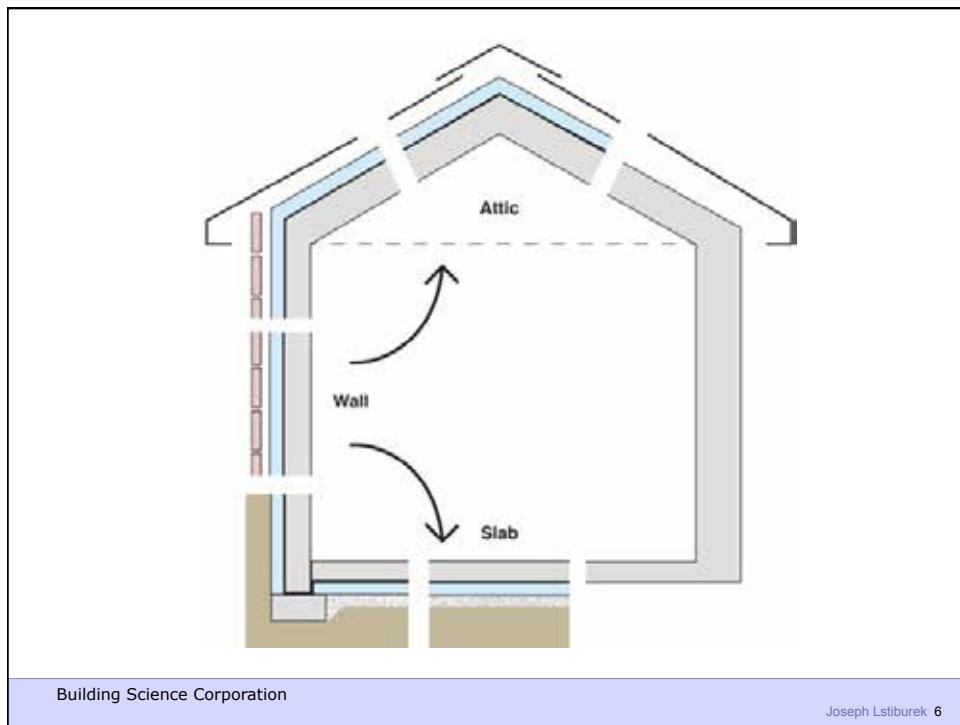
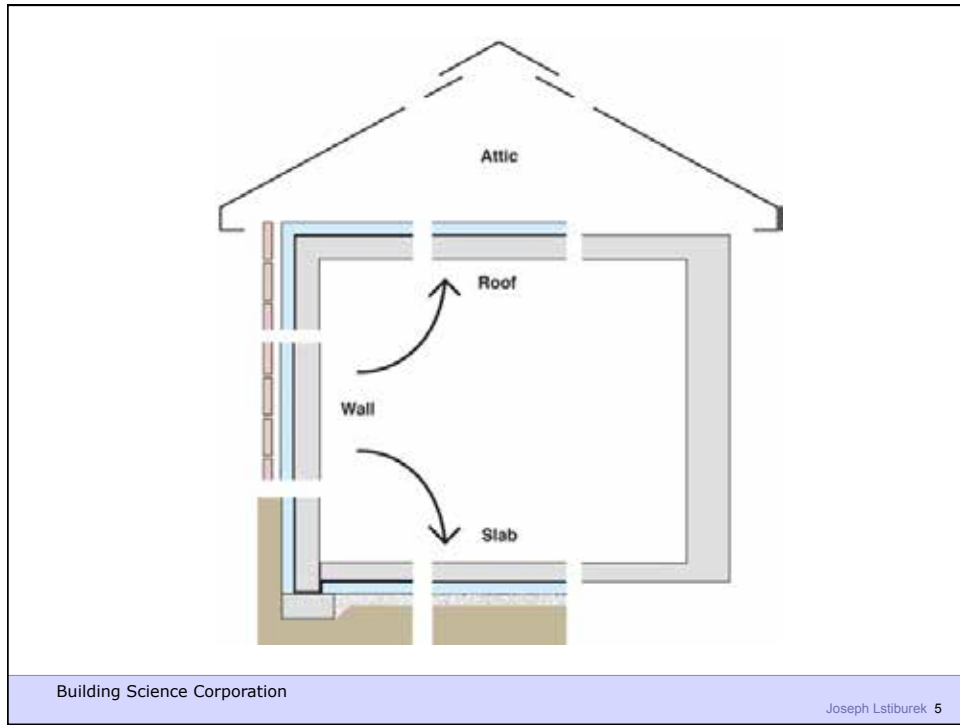

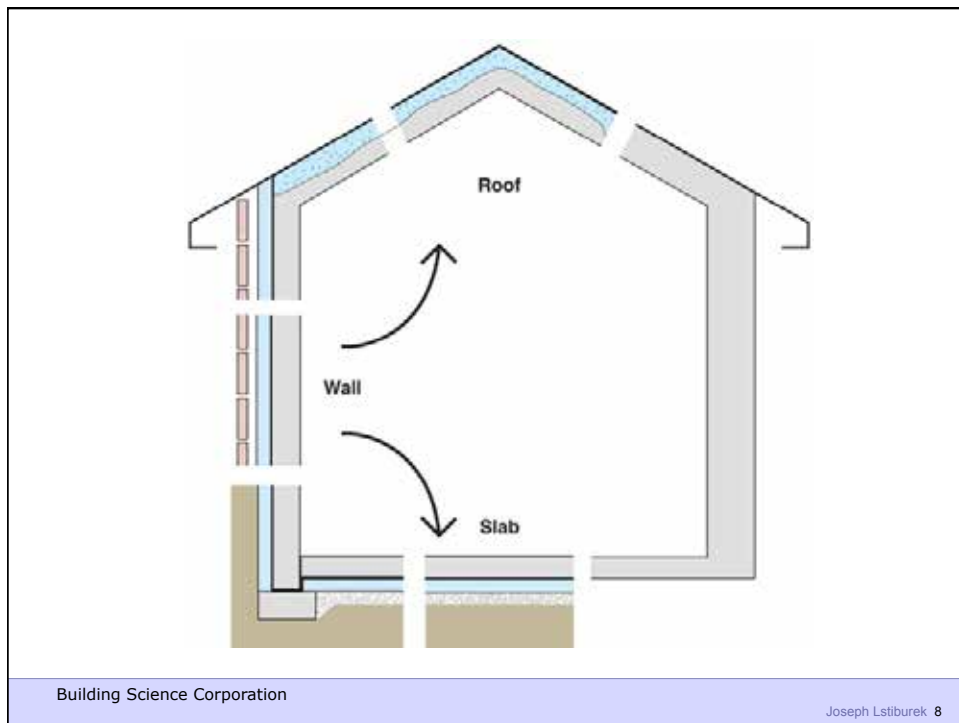
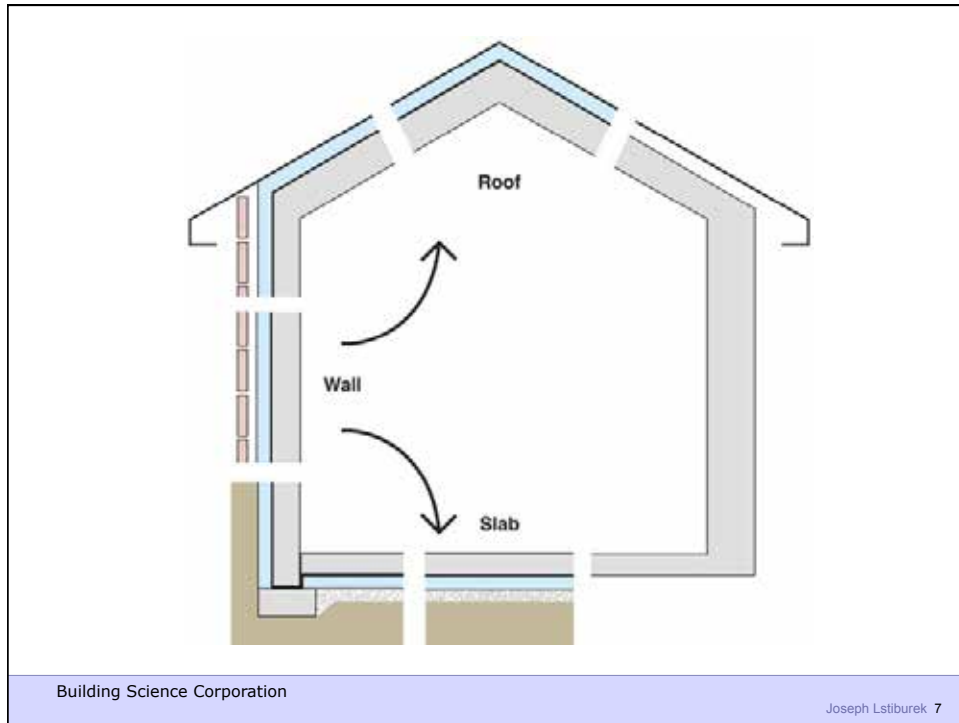

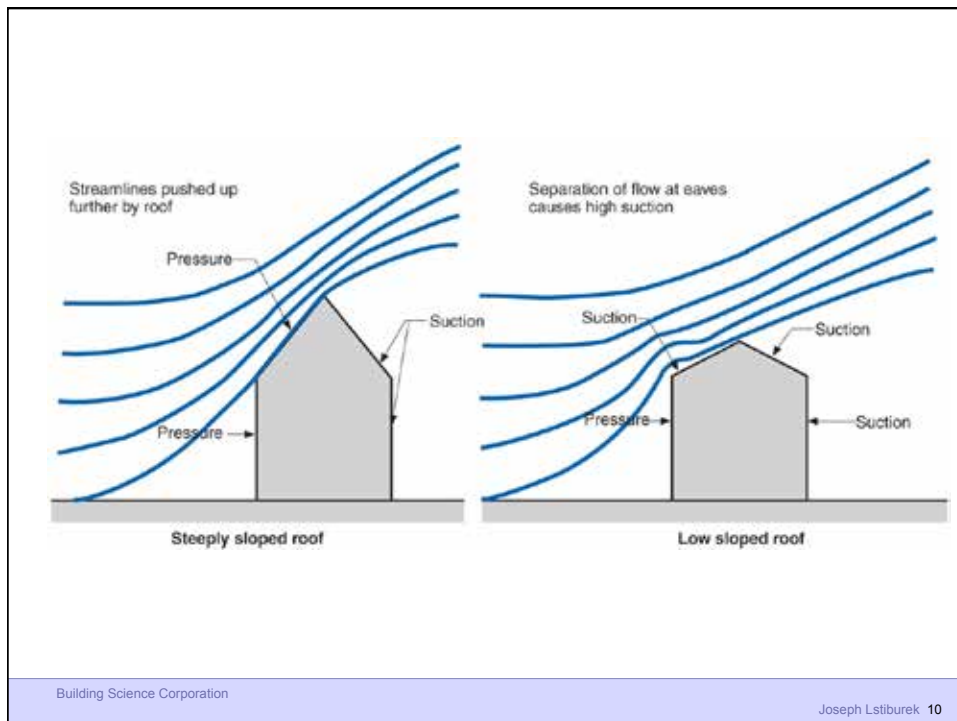
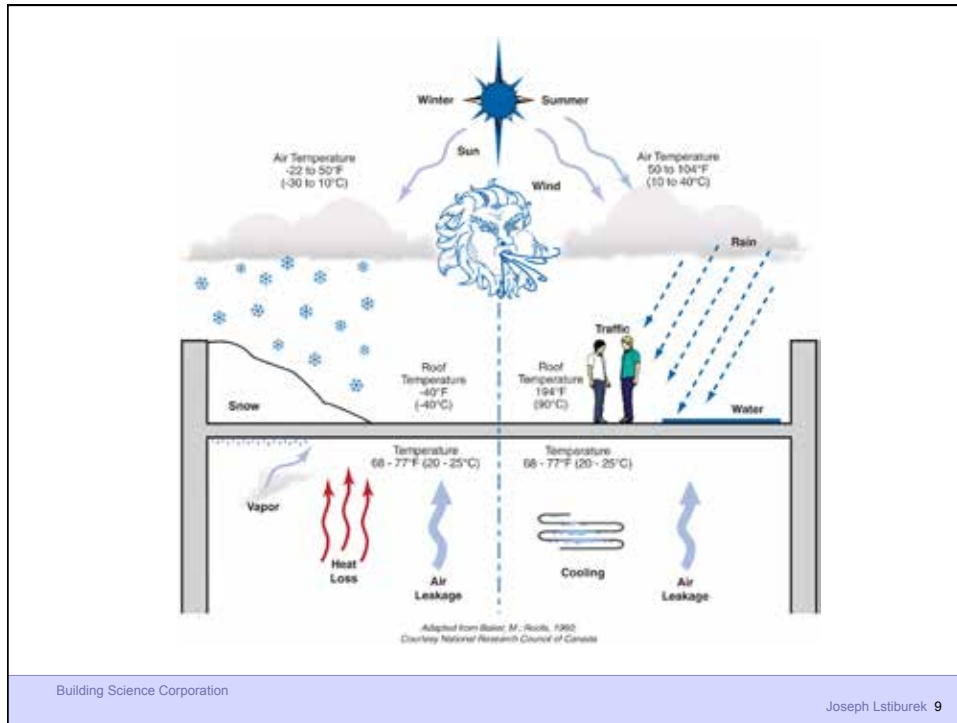

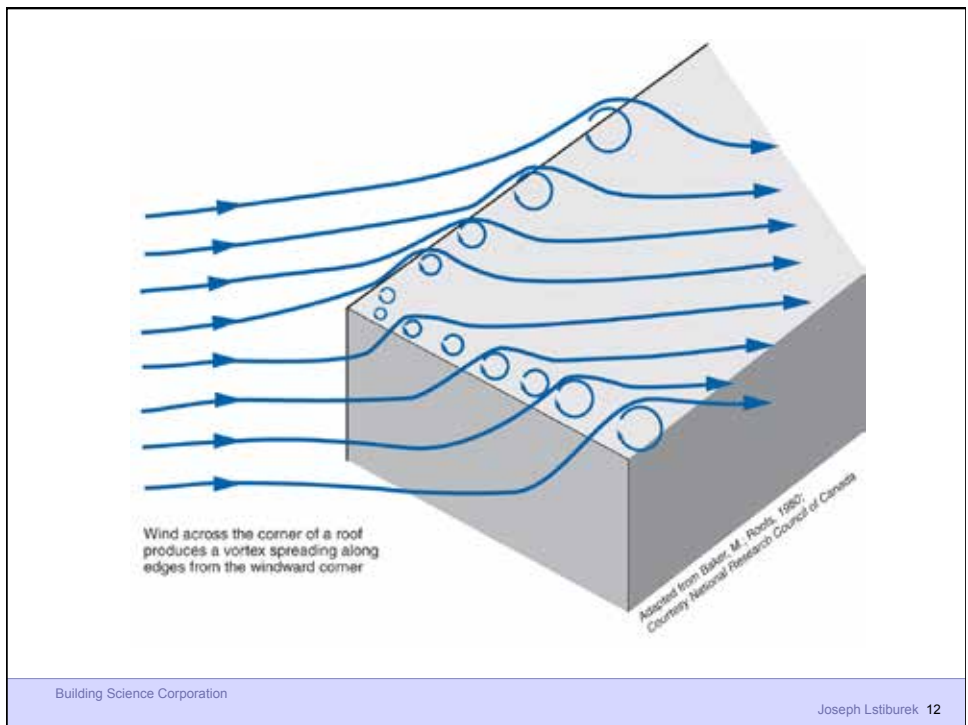
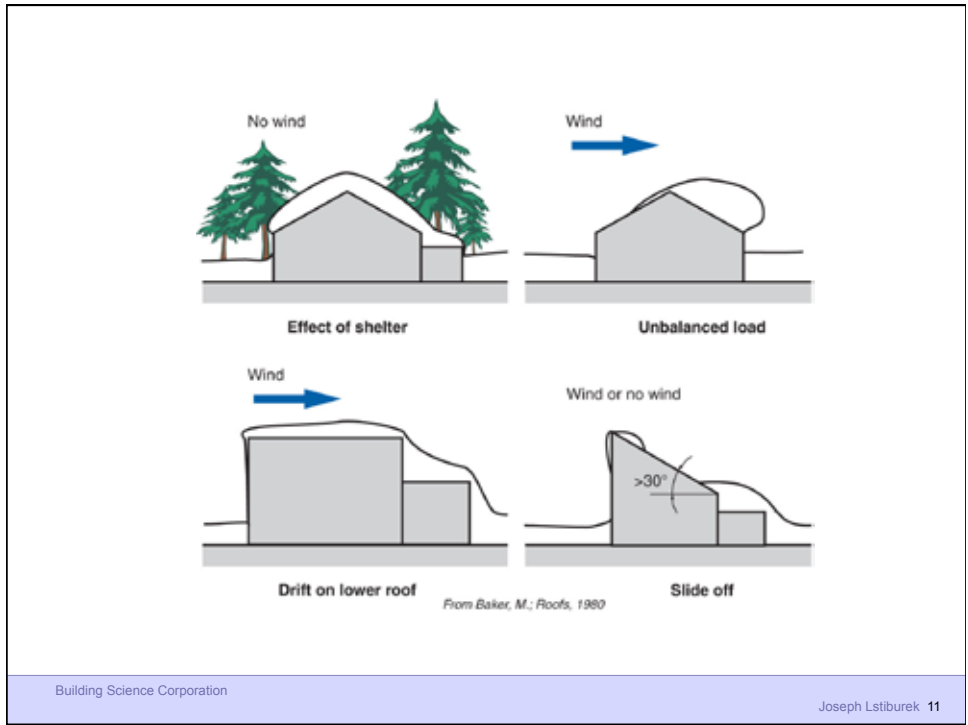

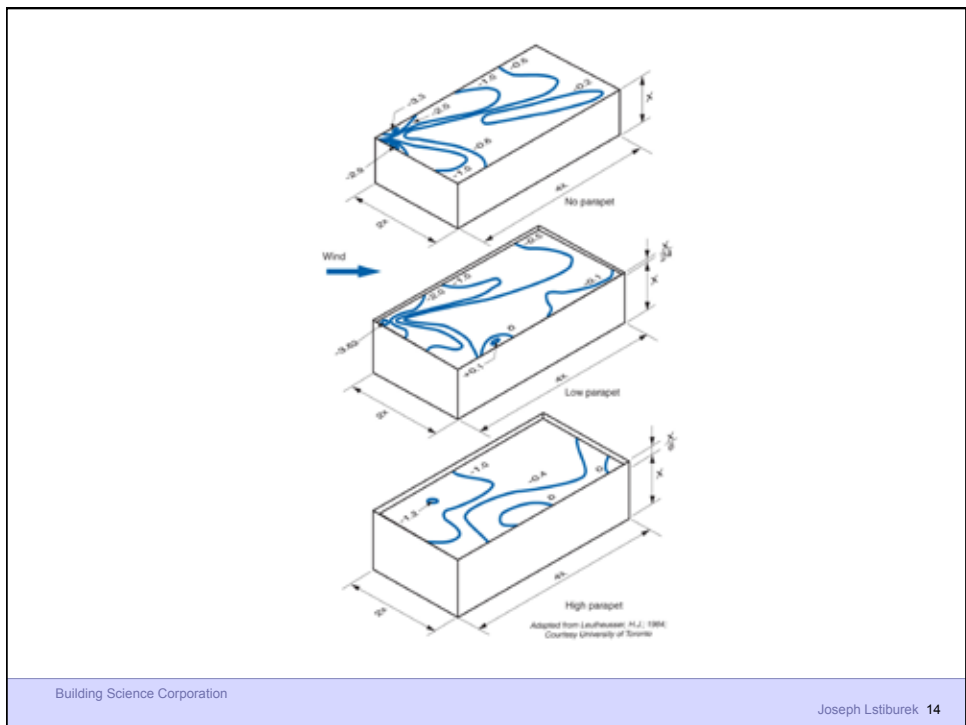
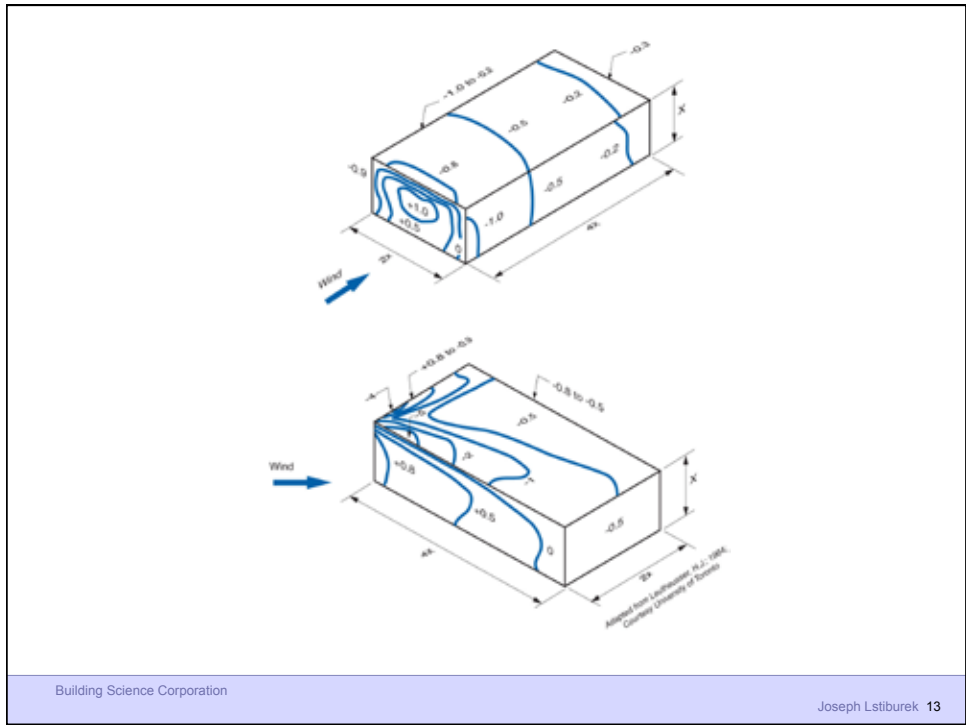

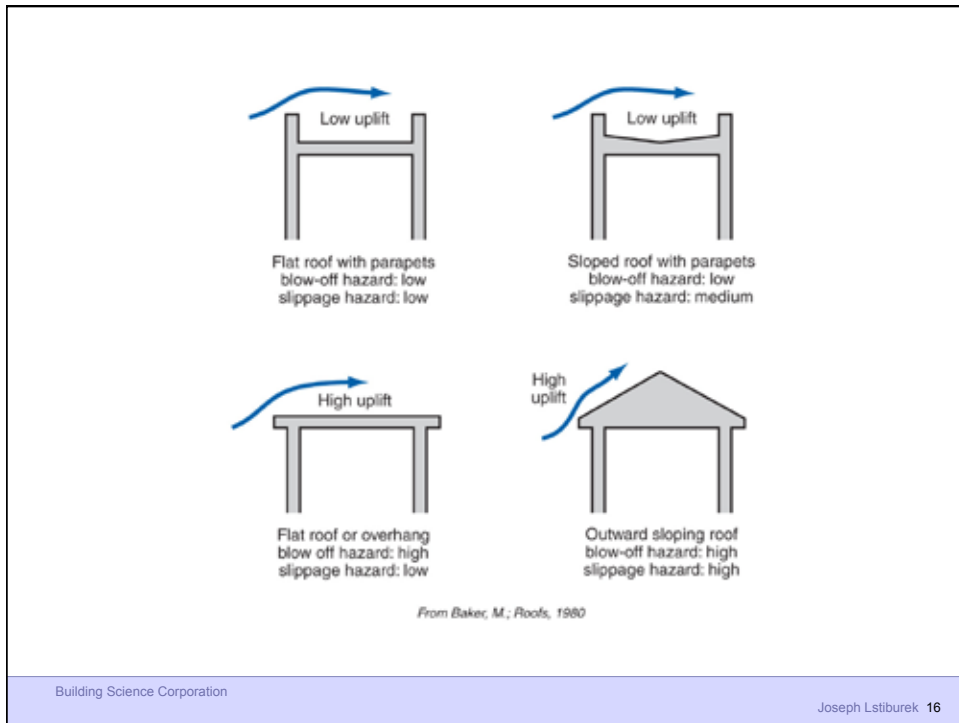
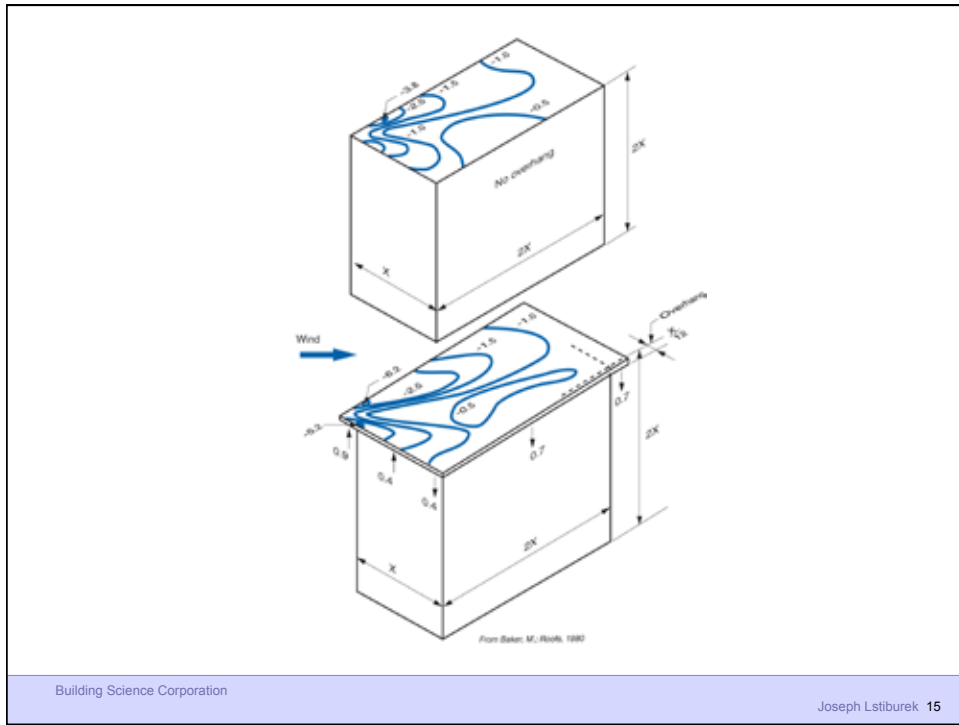

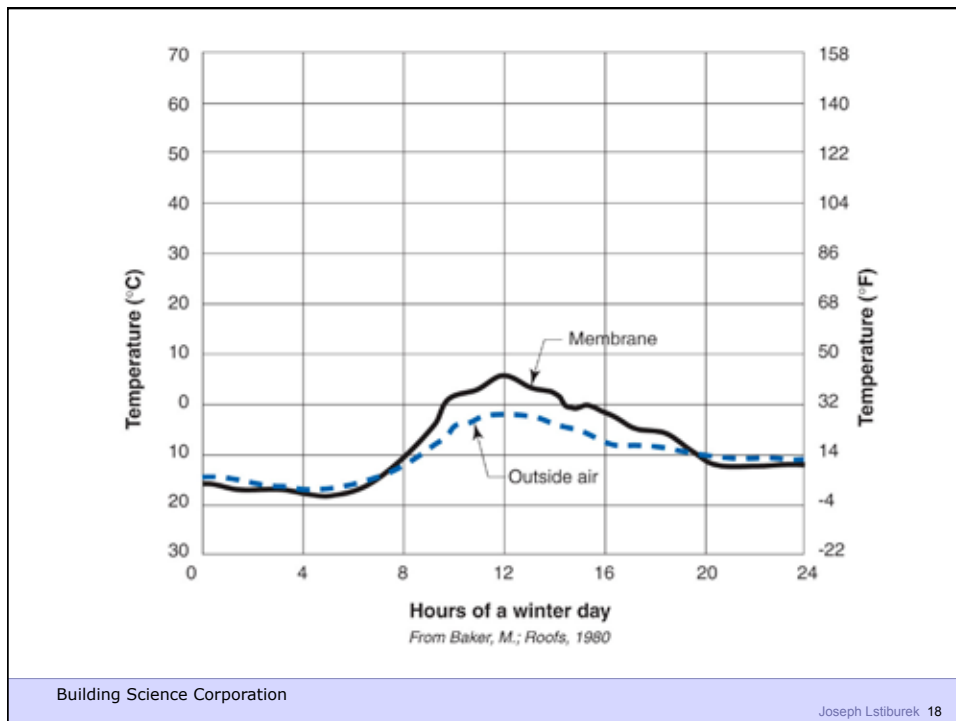
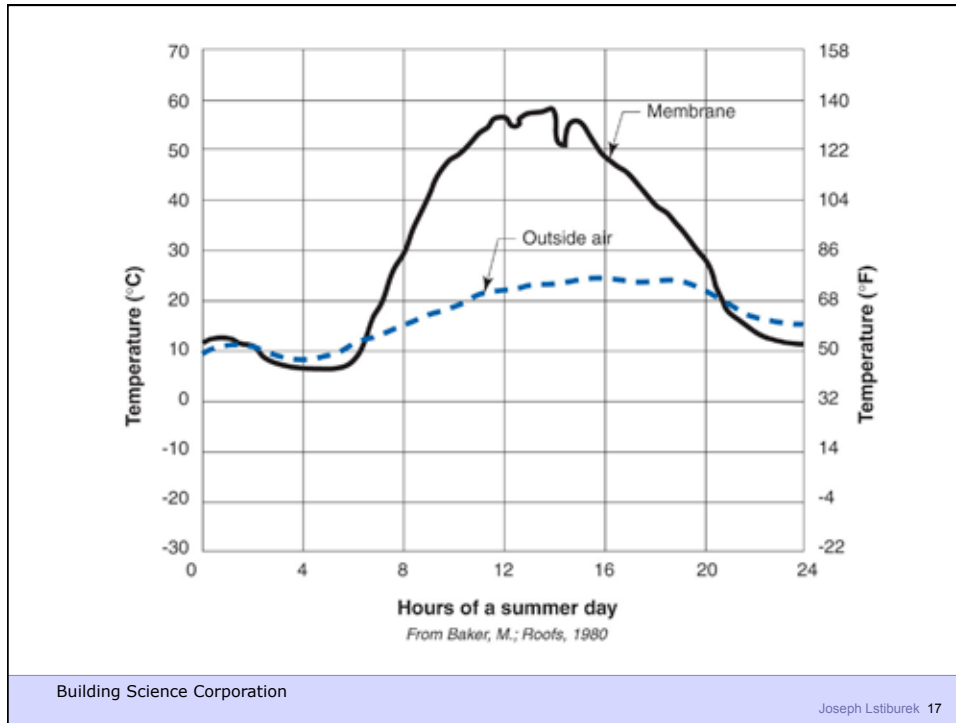

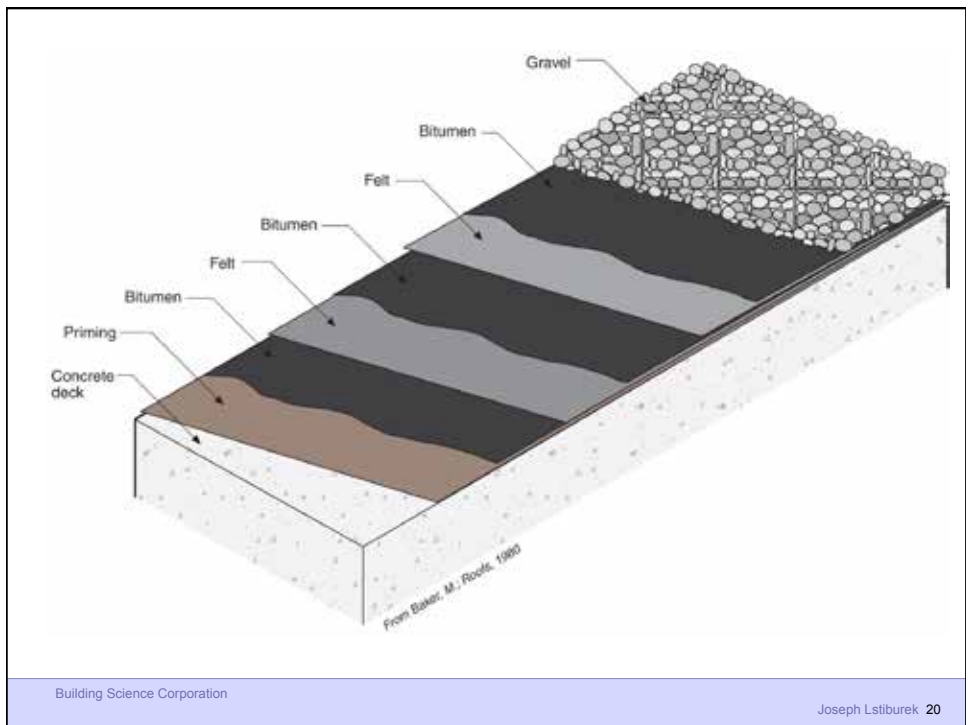
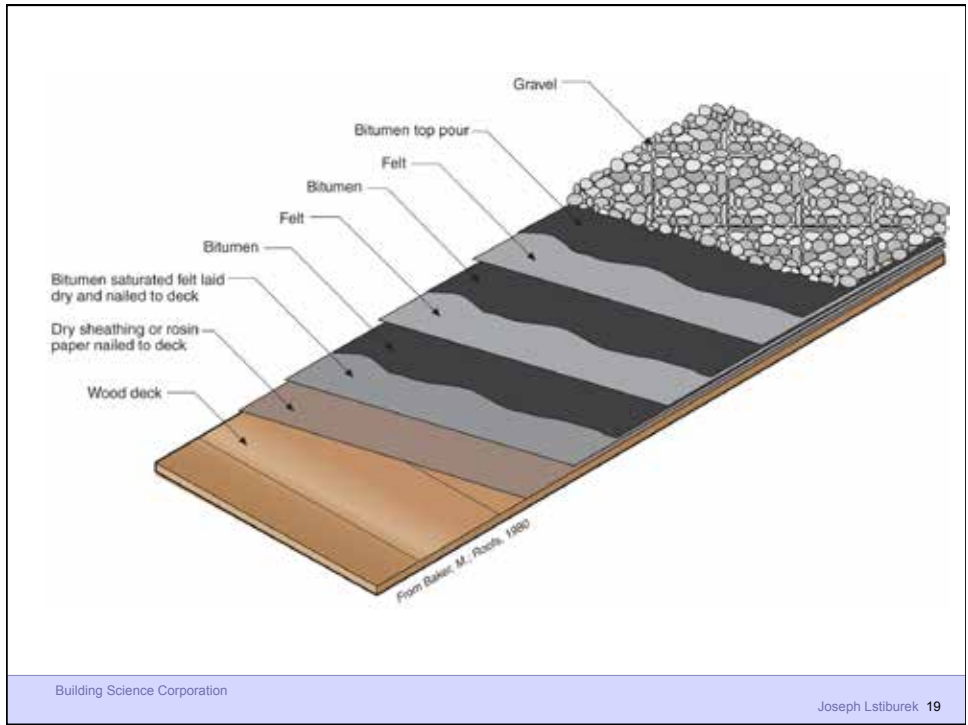

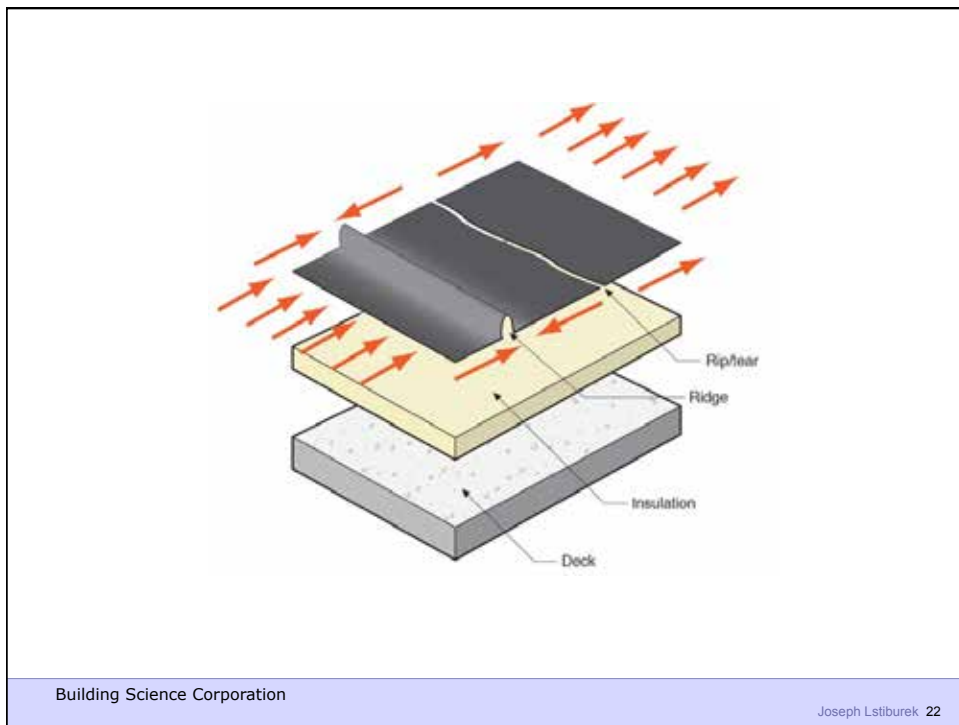
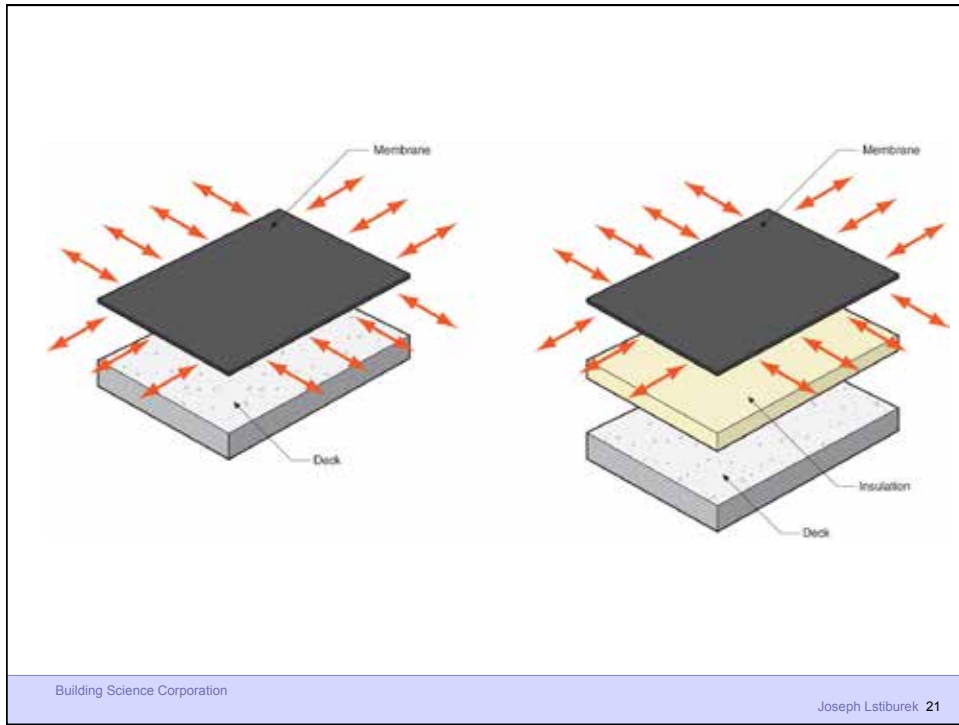

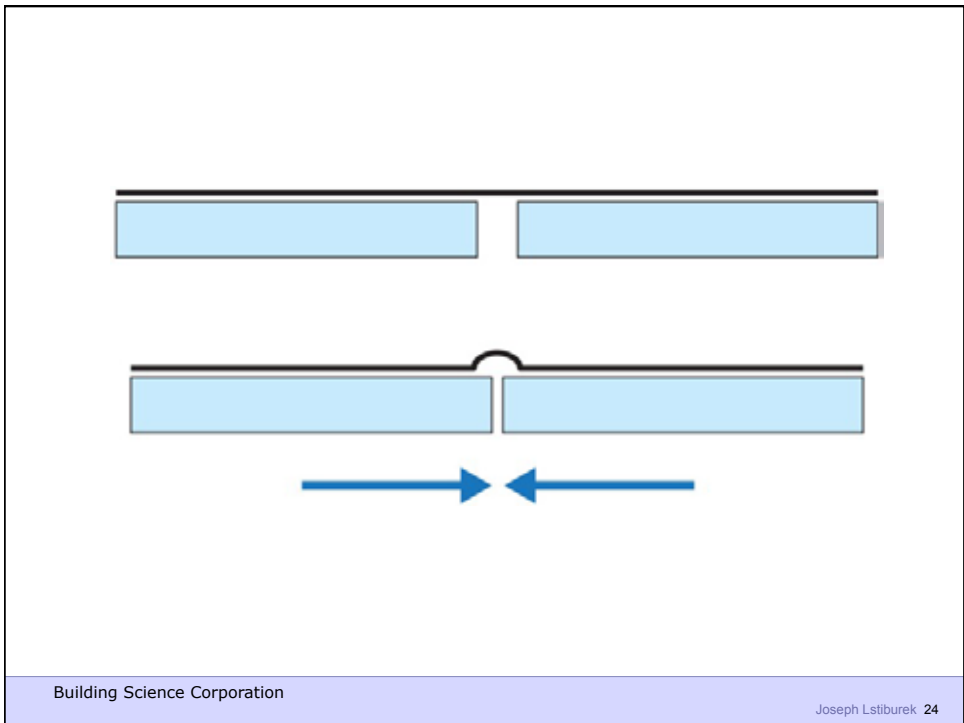

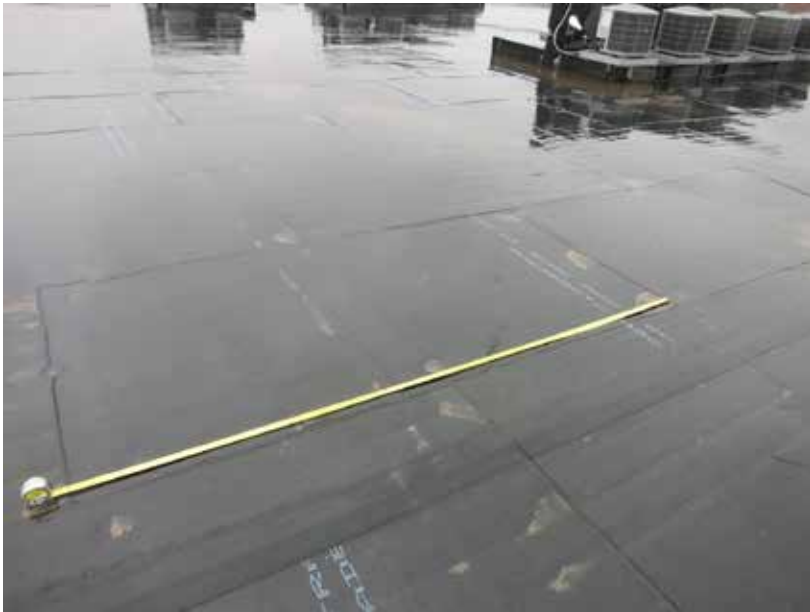

Building Science Corporation

Joseph Lstiburek 25

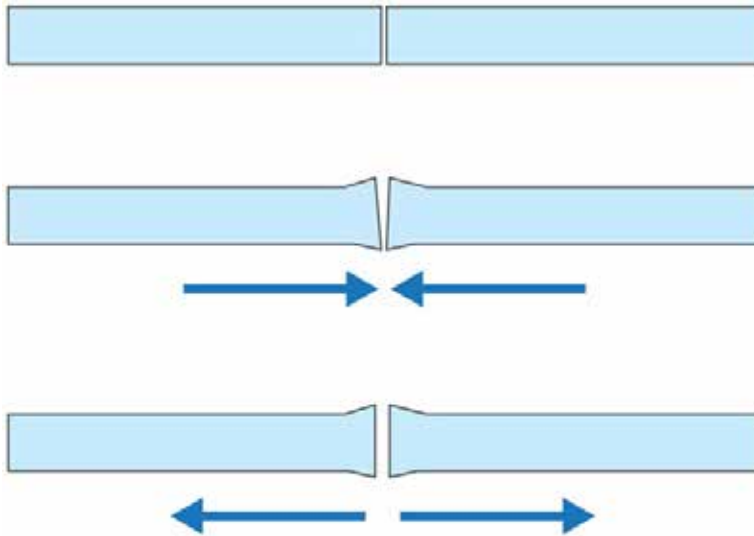

Building Science Corporation

Joseph Lstiburek 26

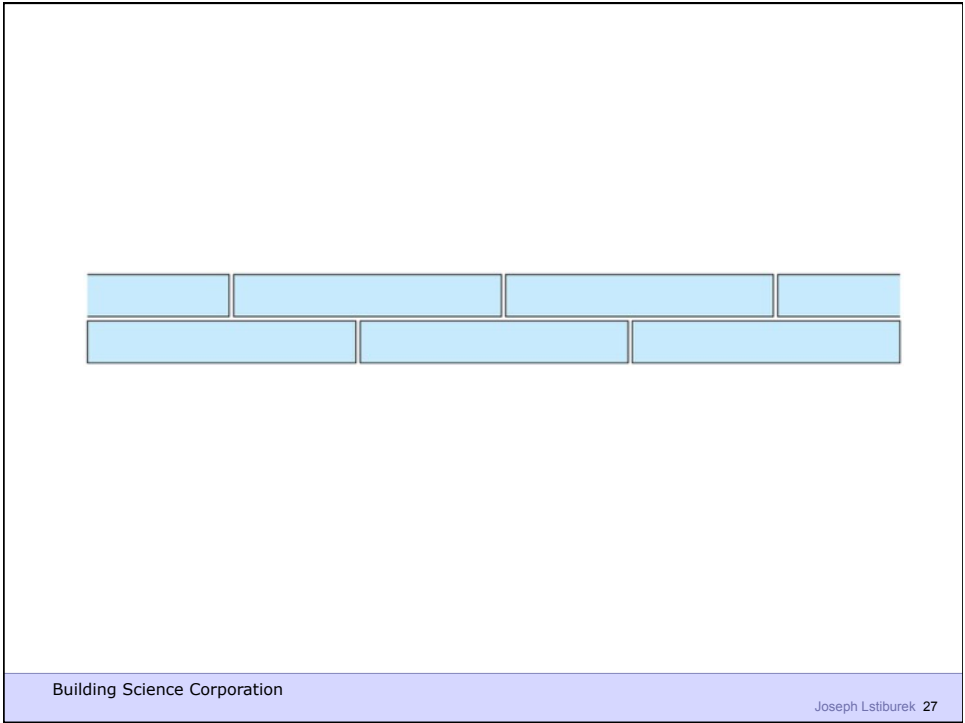

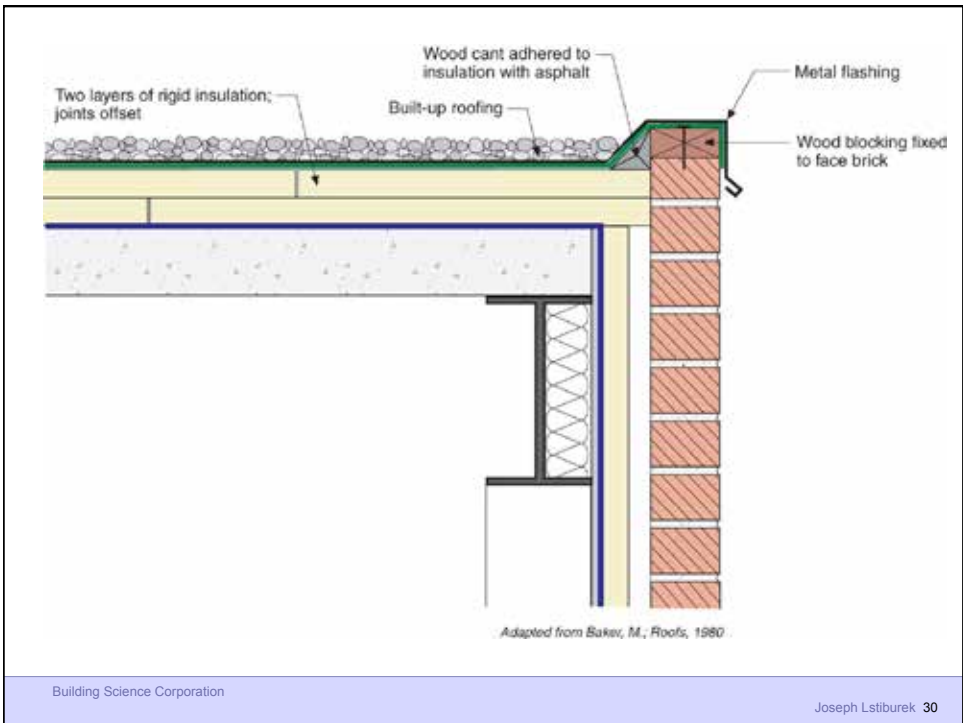
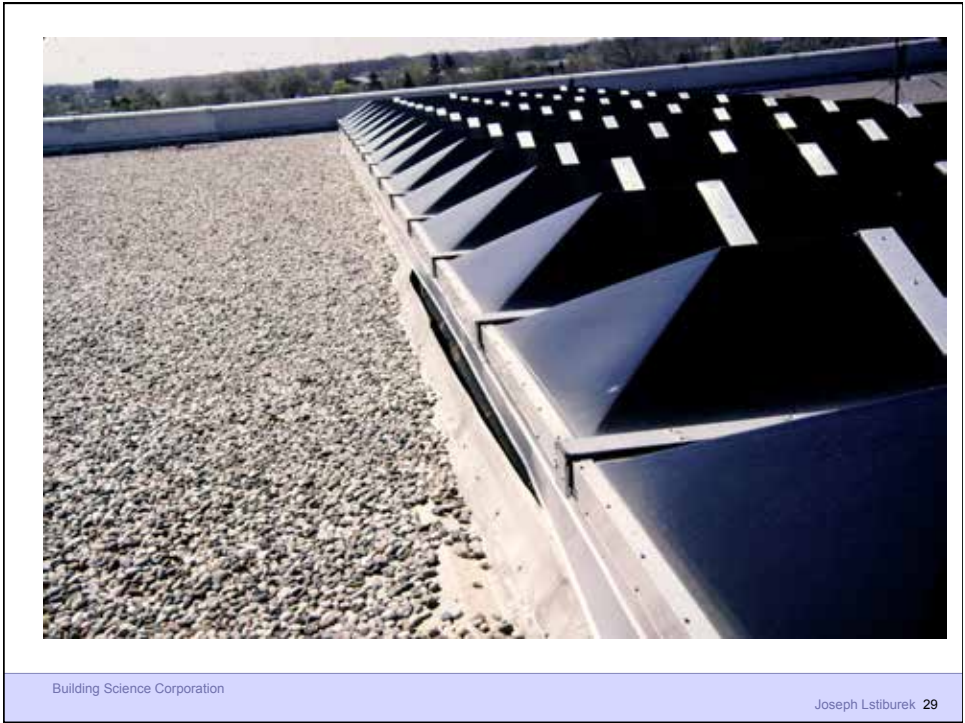

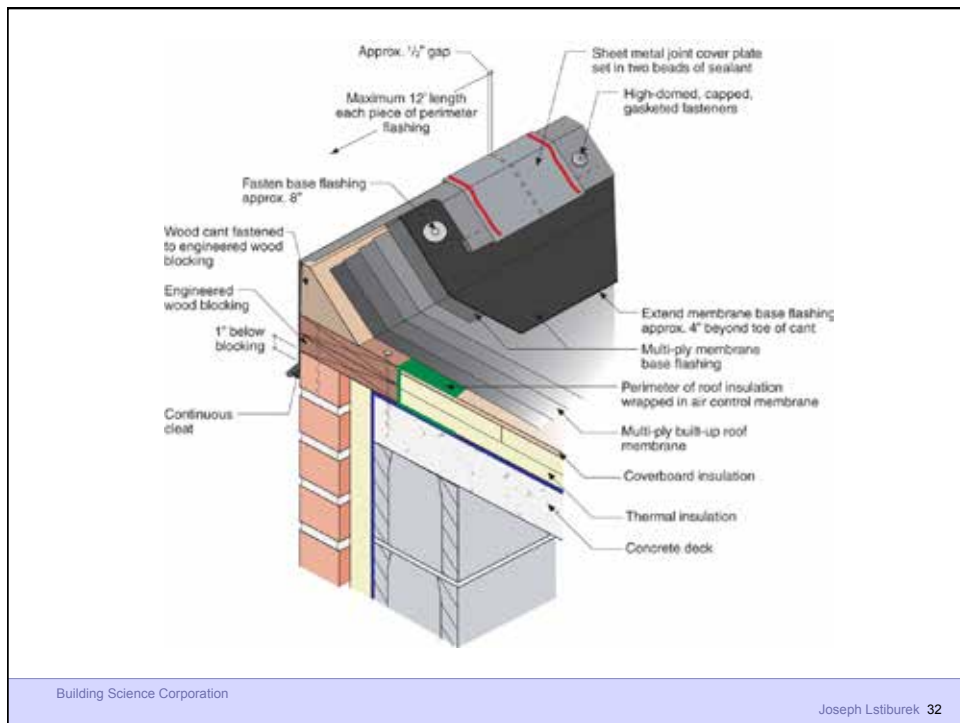
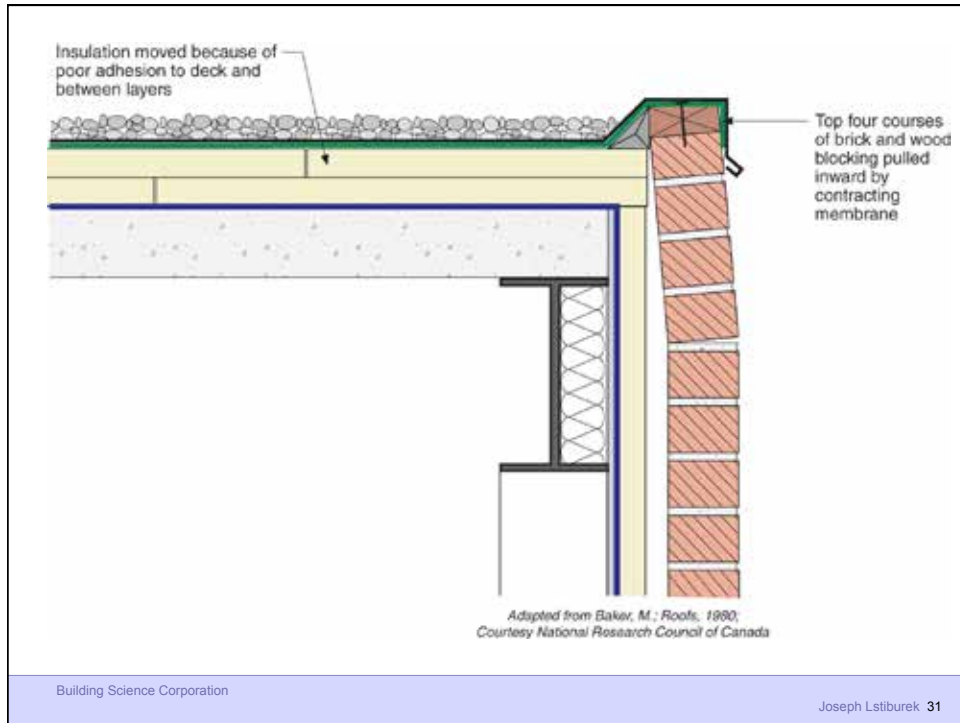

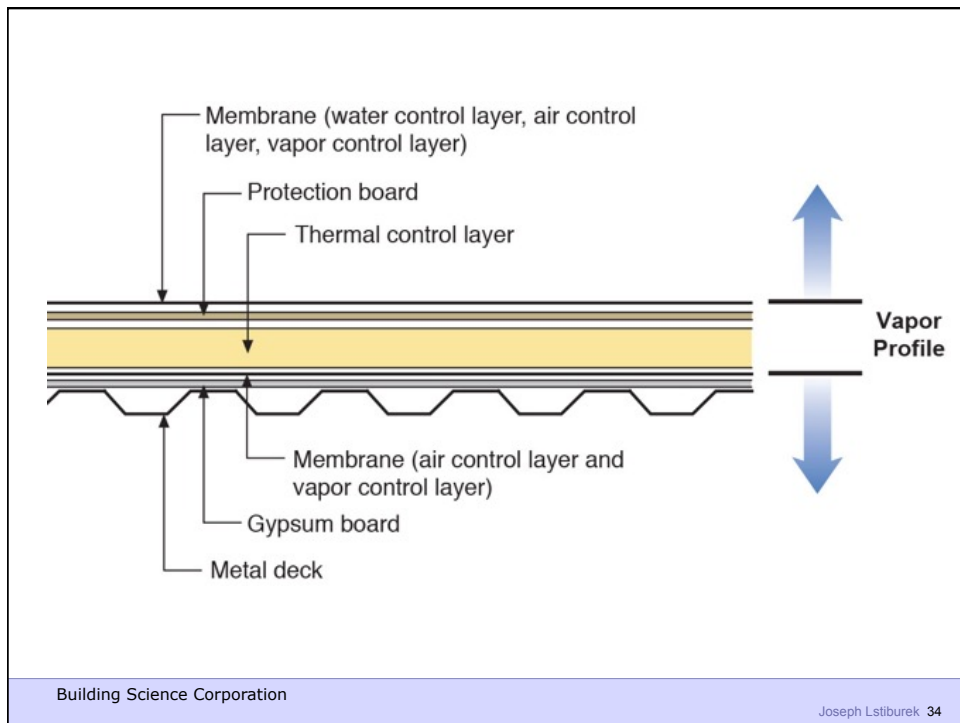
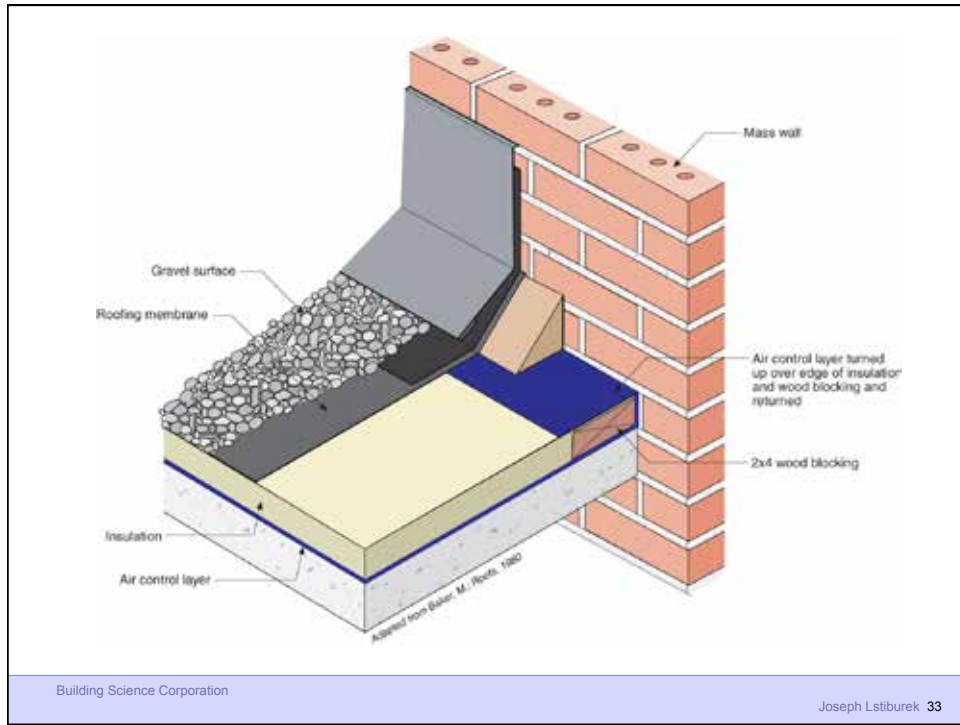

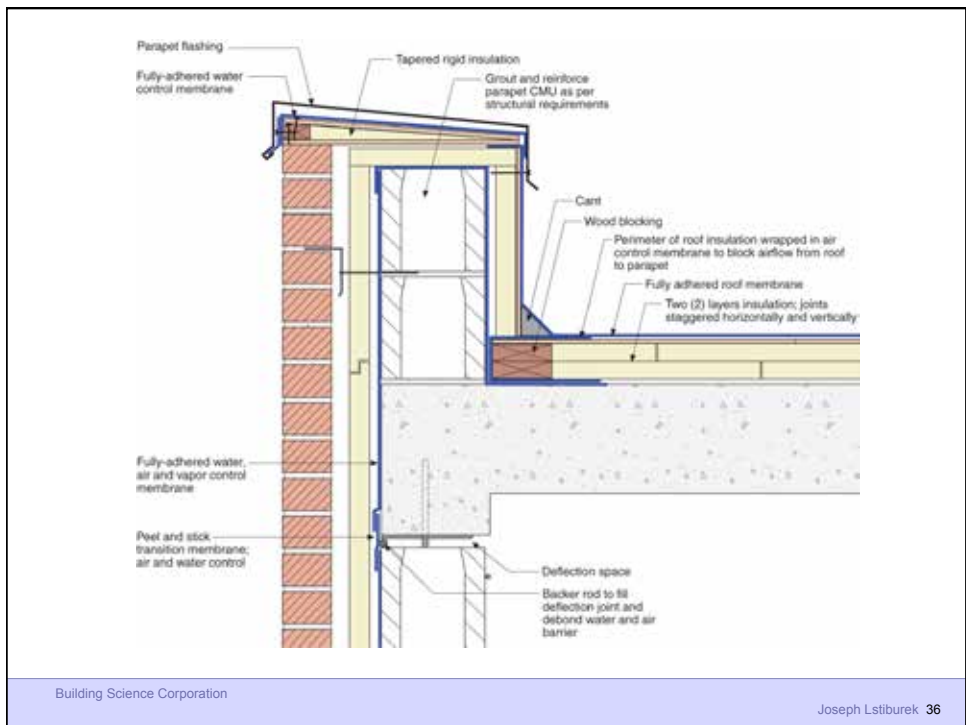
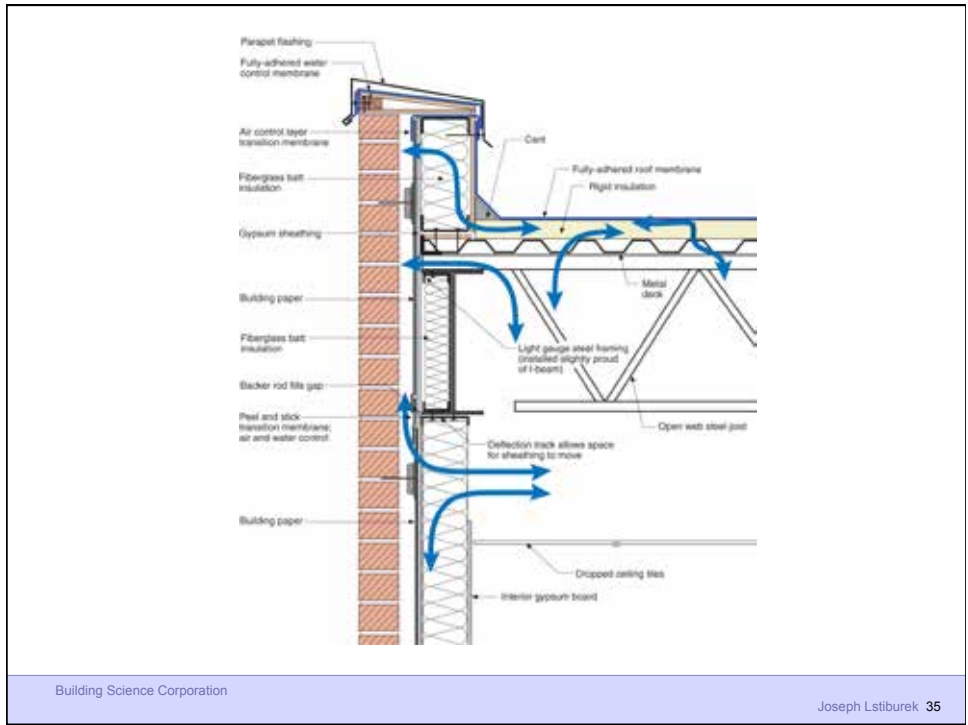

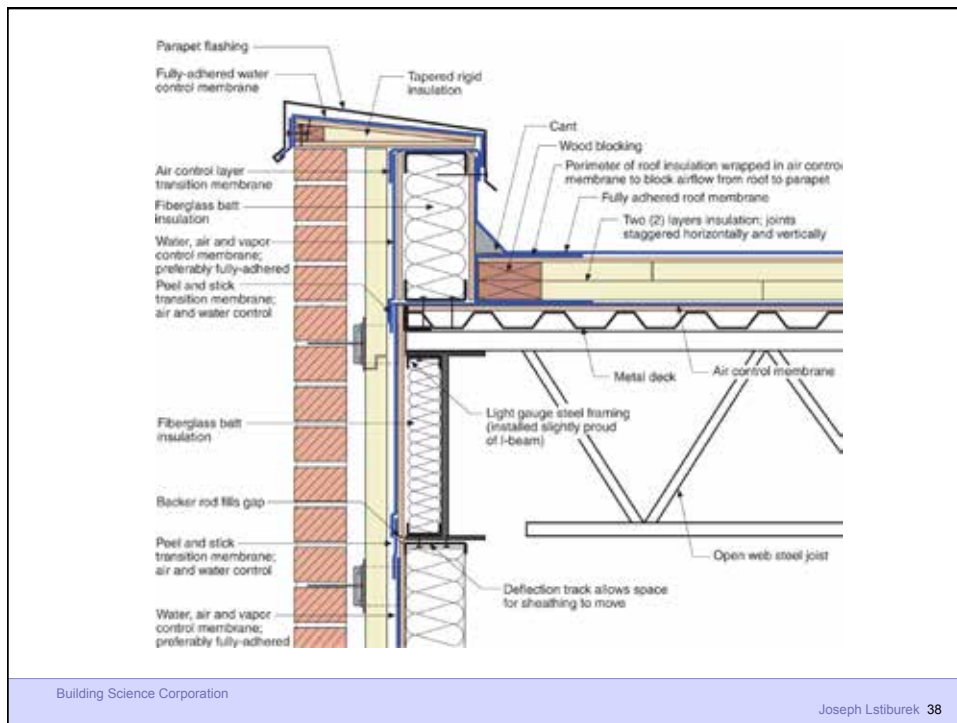
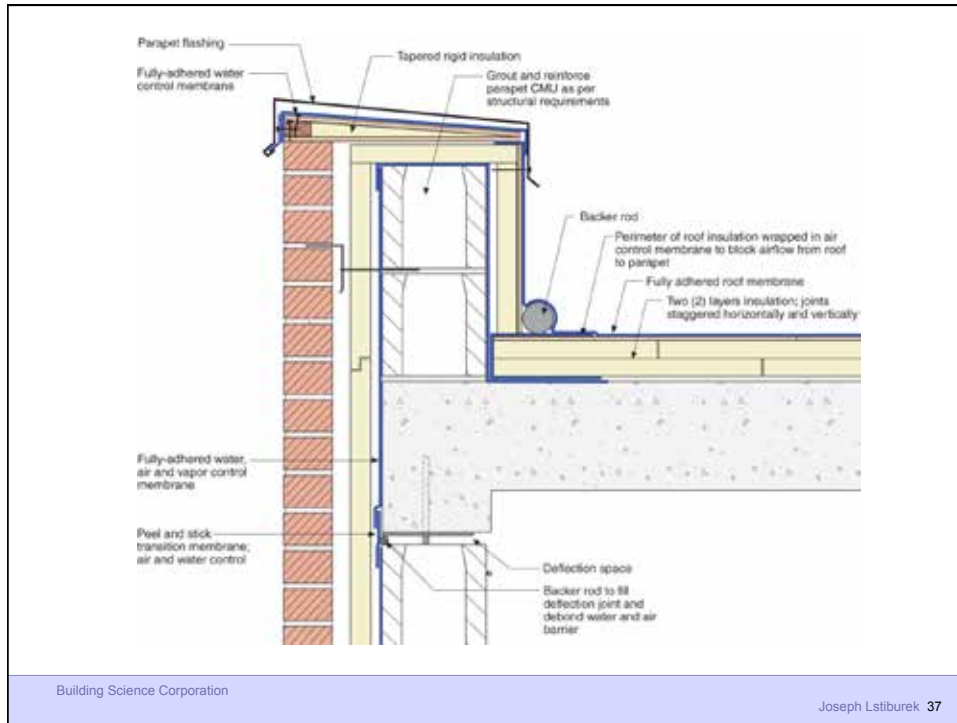

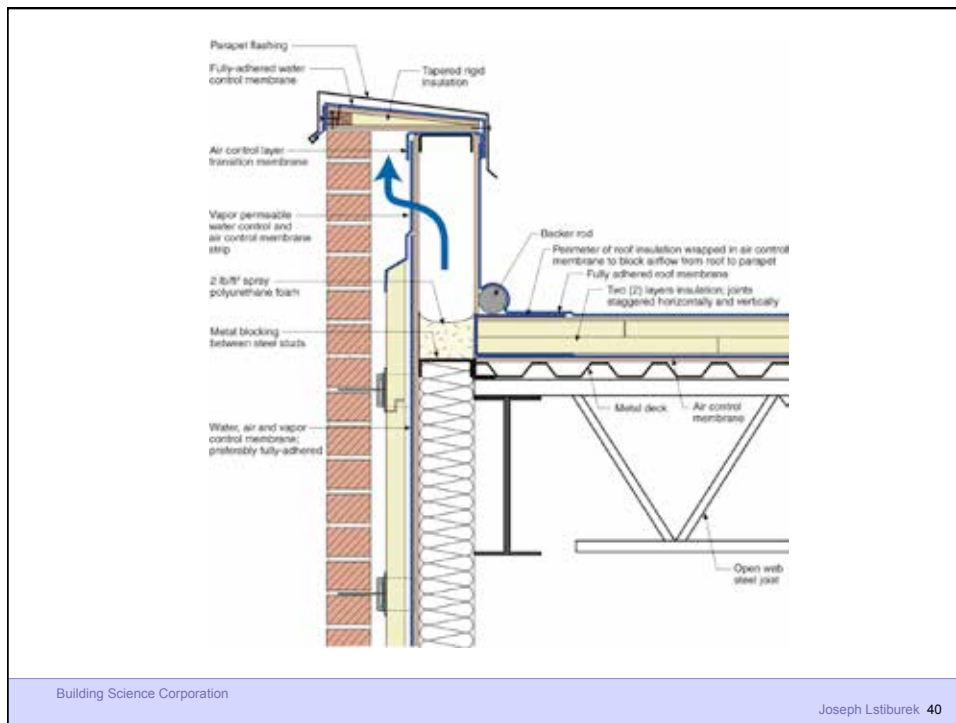
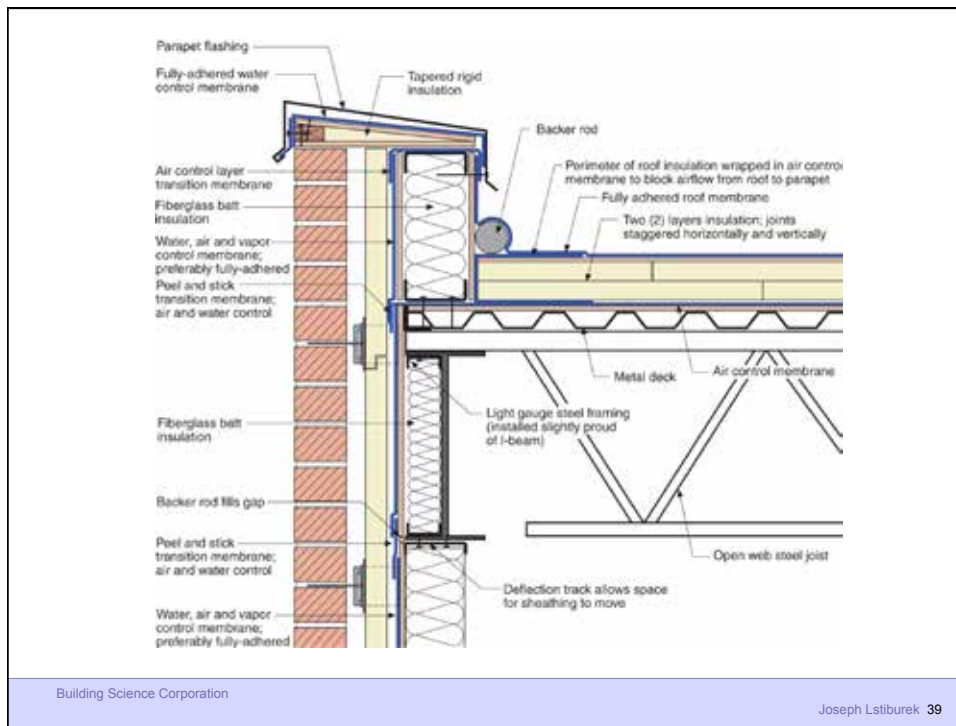

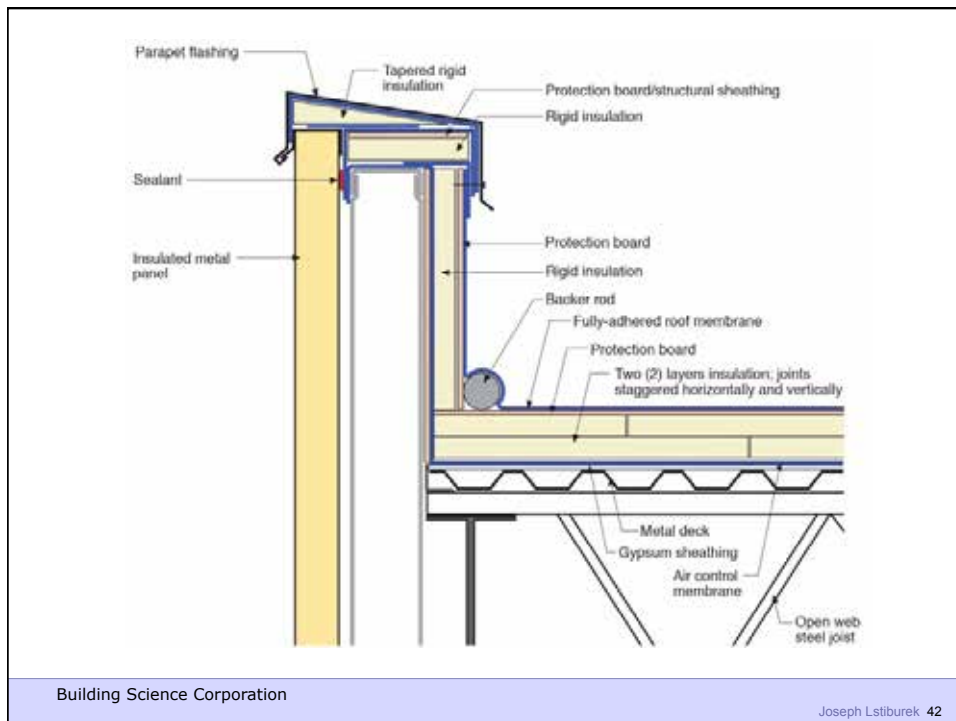
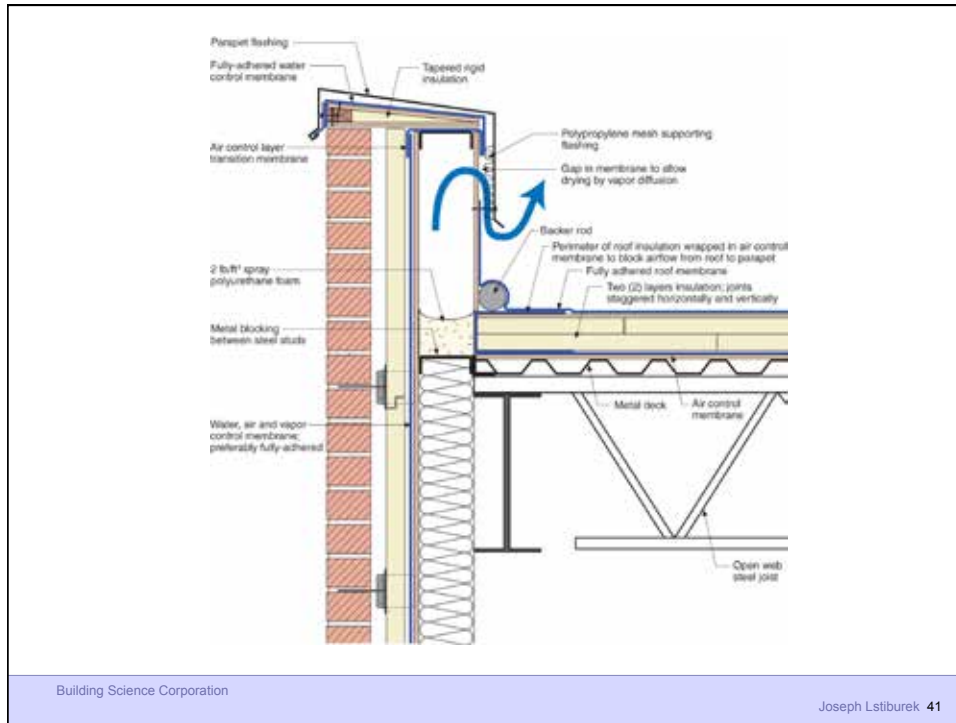

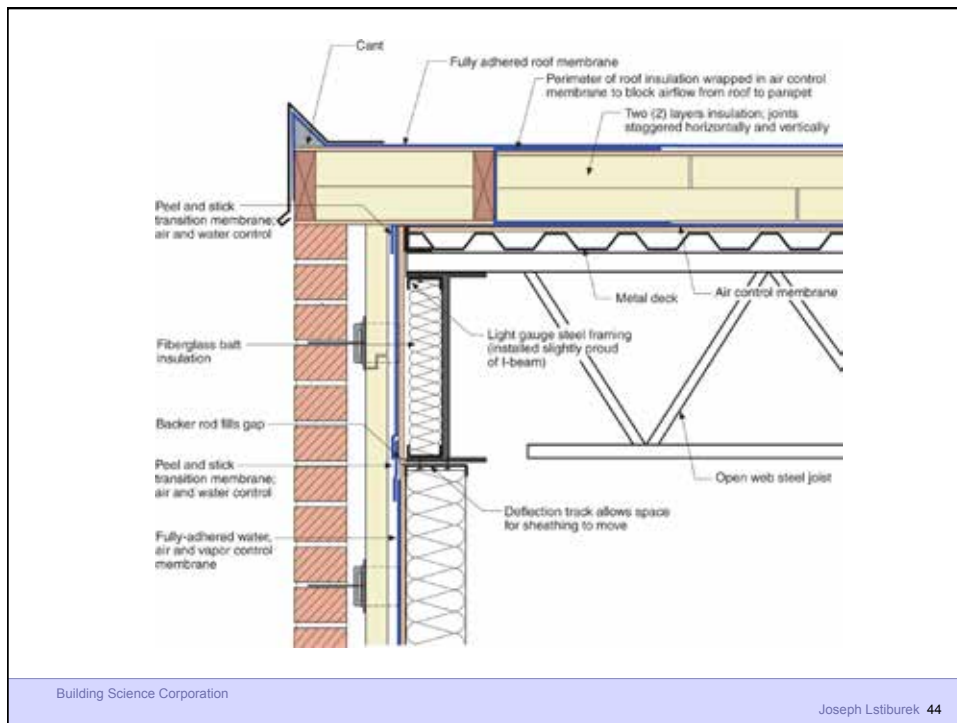
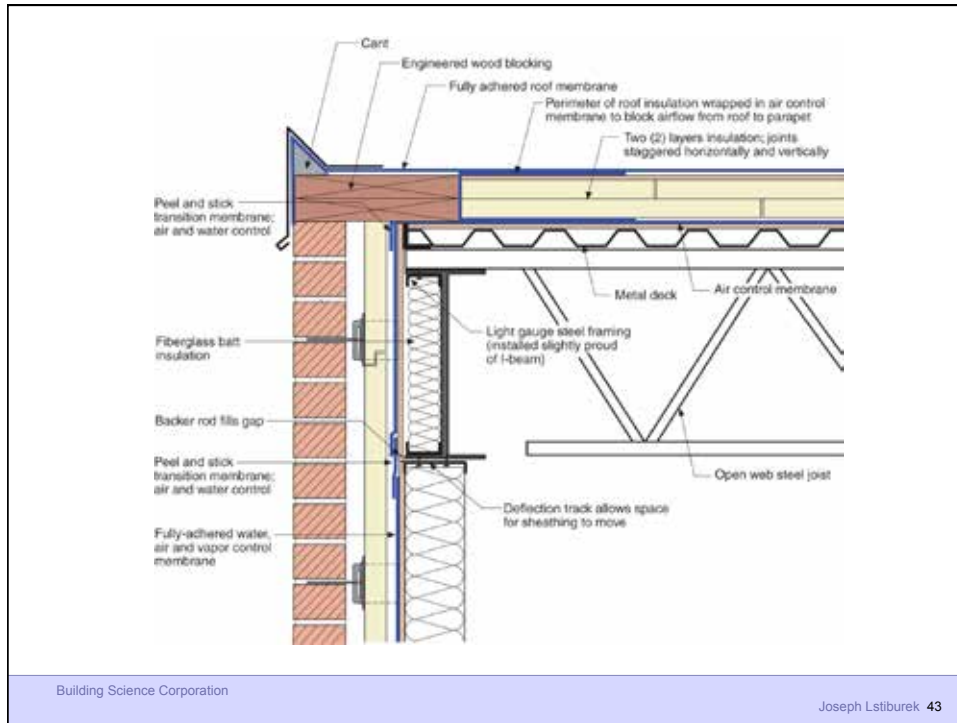

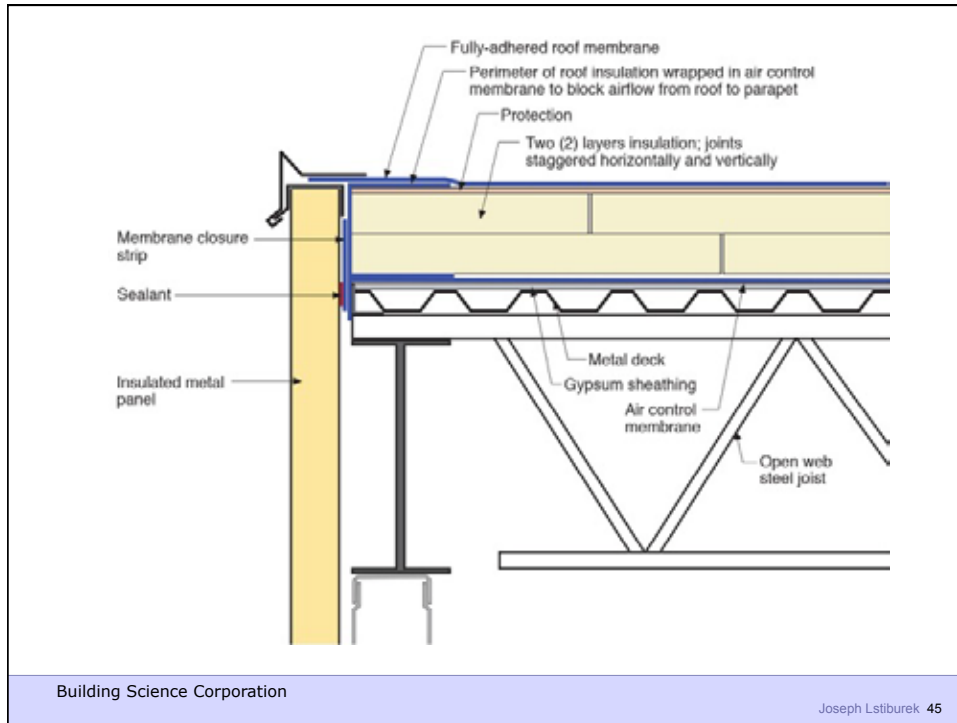

It's a Case of Black or White

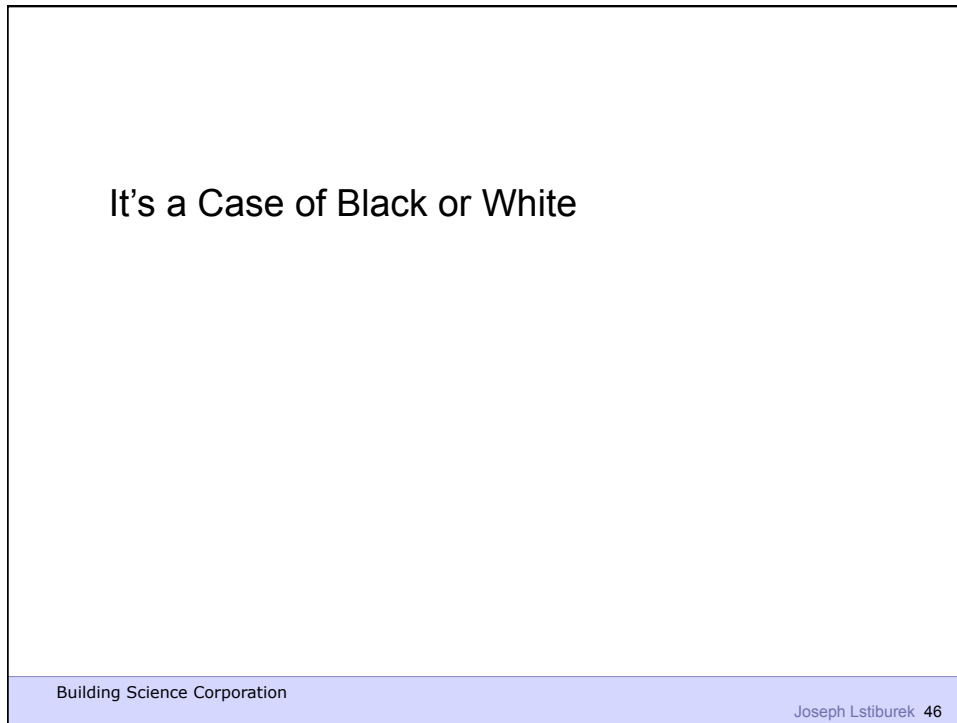

It's a Case of Black or White
Arrhenius

Building Science Corporation

Joseph Lstiburek 47

It's a Case of Black or White
Arrhenius
Every 10 degrees C – double the “badness”

Building Science Corporation

Joseph Lstiburek 48

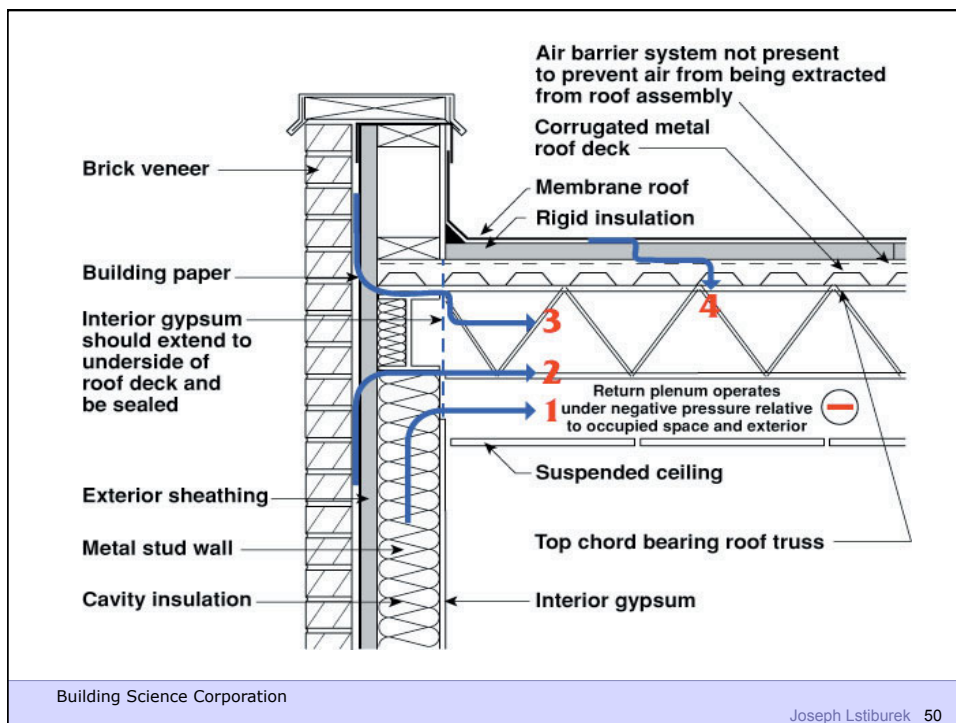
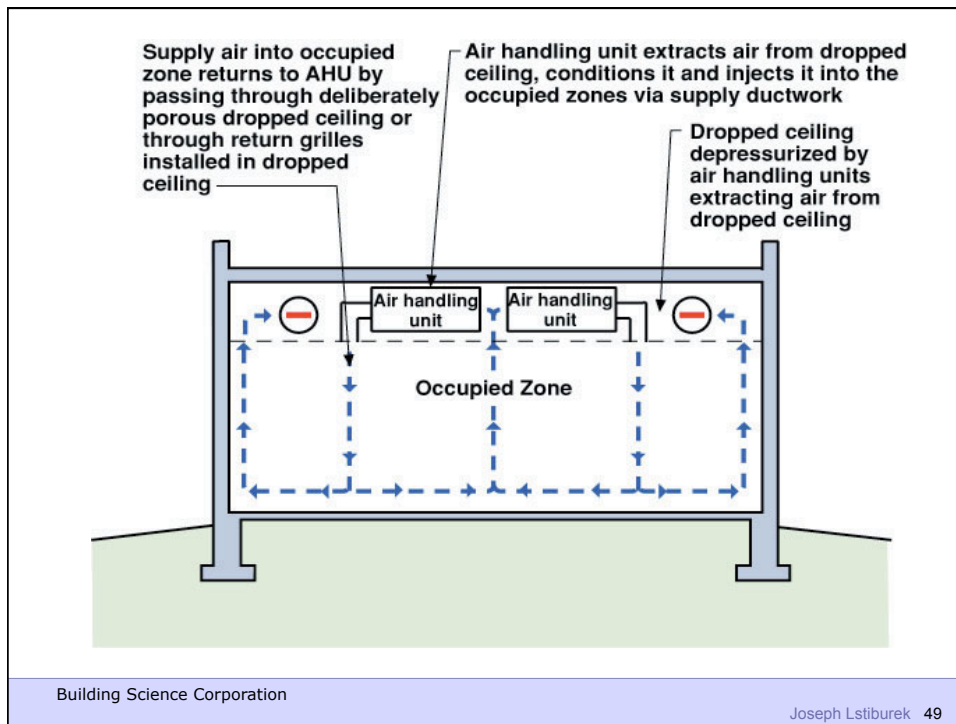



Building Science Corporation

Joseph Lstiburek 51

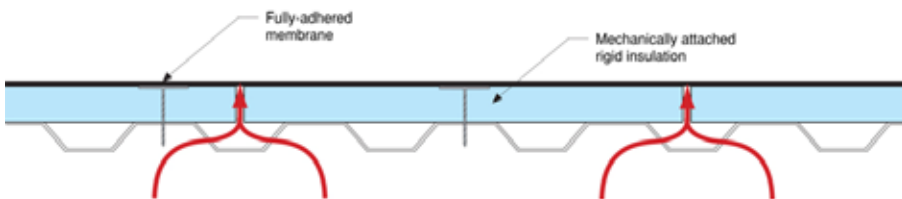

Building Science Corporation

Joseph Lstiburek 52



Building Science Corporation

Joseph Lstiburek 53

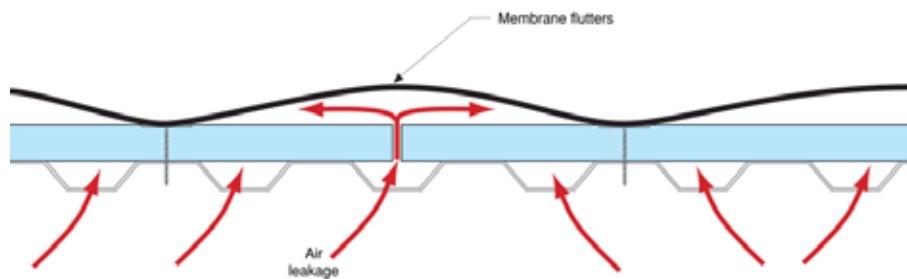

Building Science Corporation

Joseph Lstiburek 54





Building Science Corporation

Joseph Lstiburek 57



Building Science Corporation

Joseph Lstiburek 58

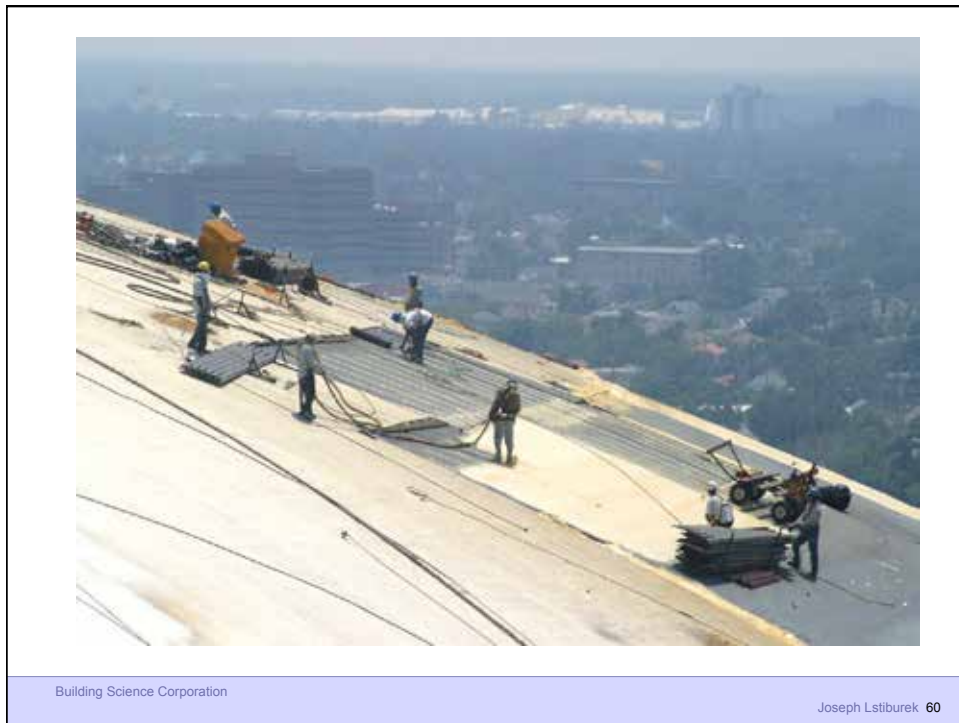
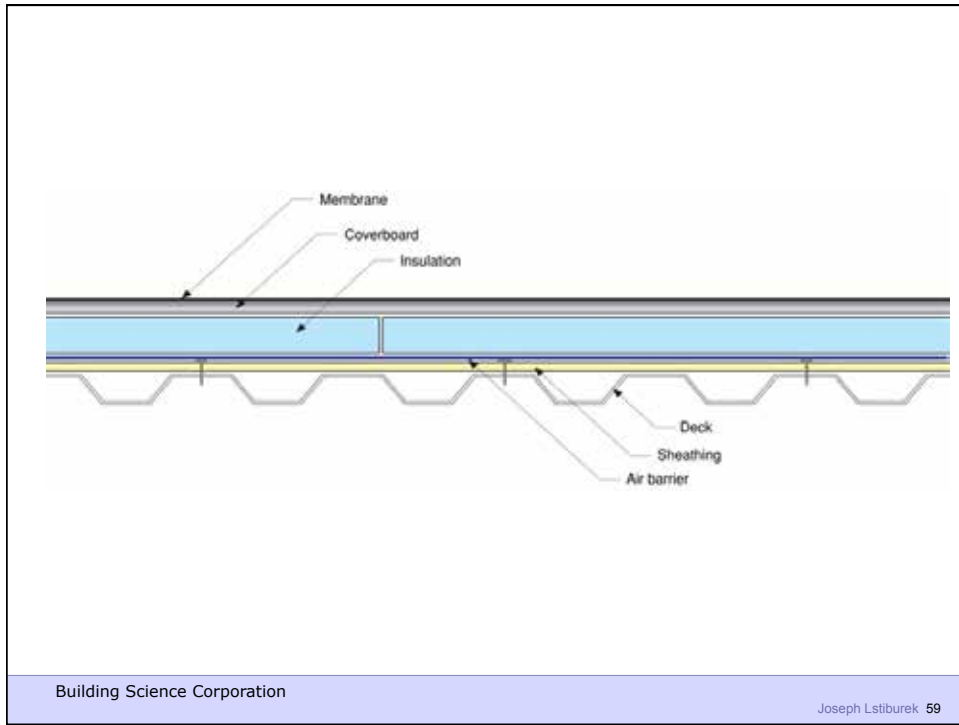

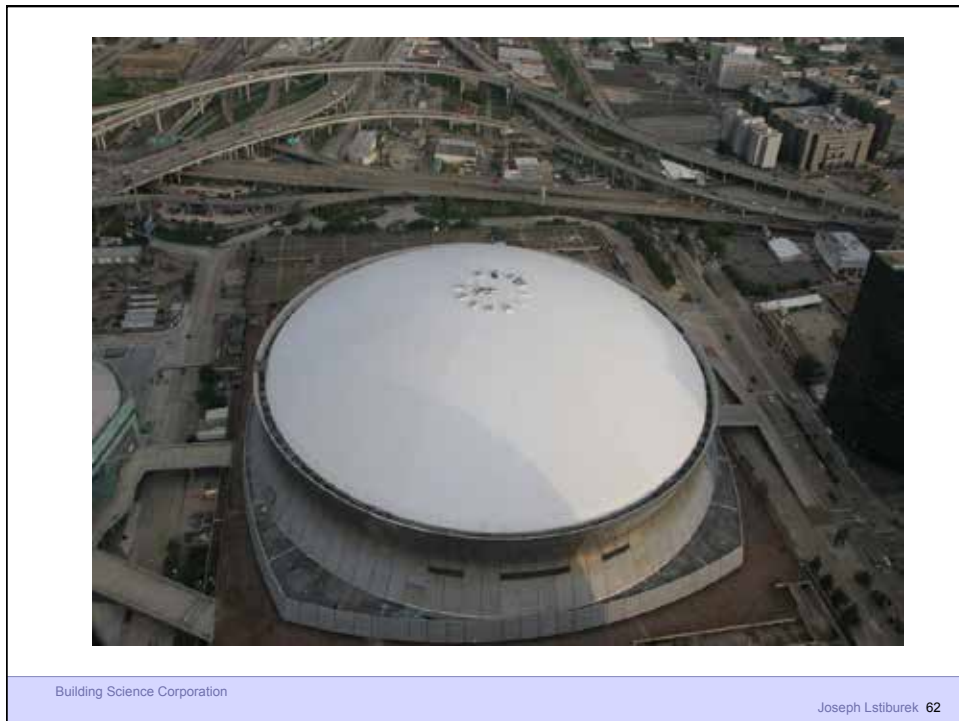
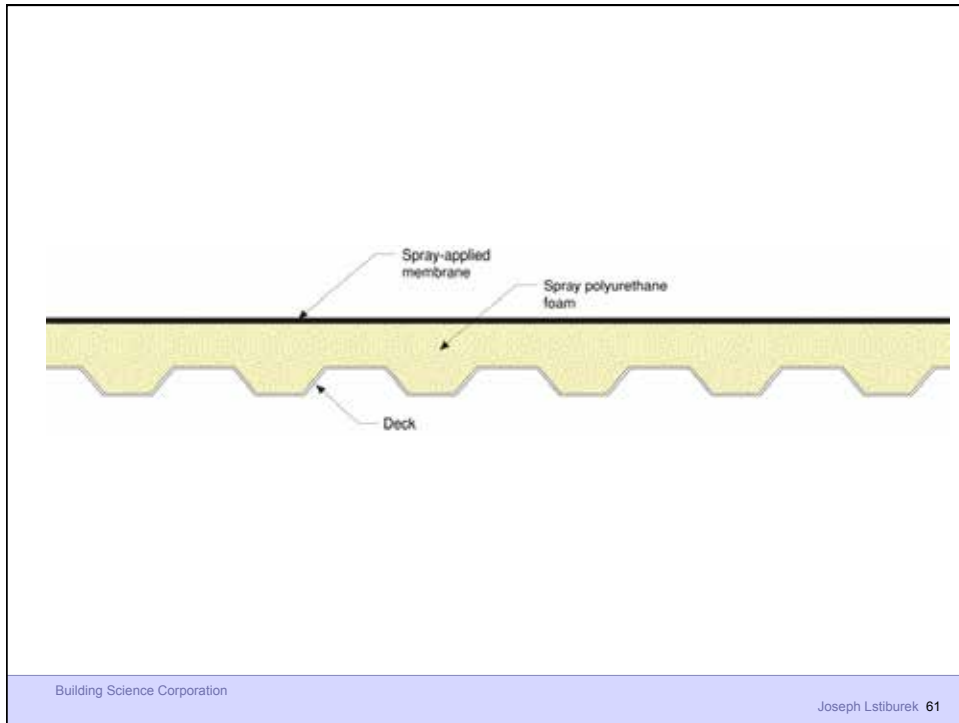

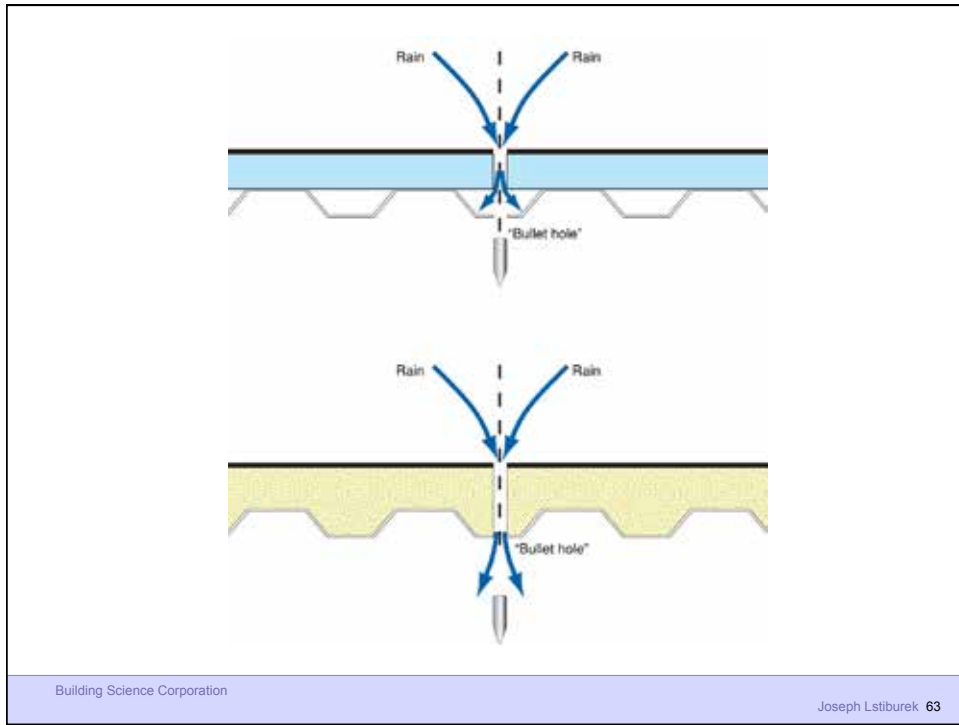



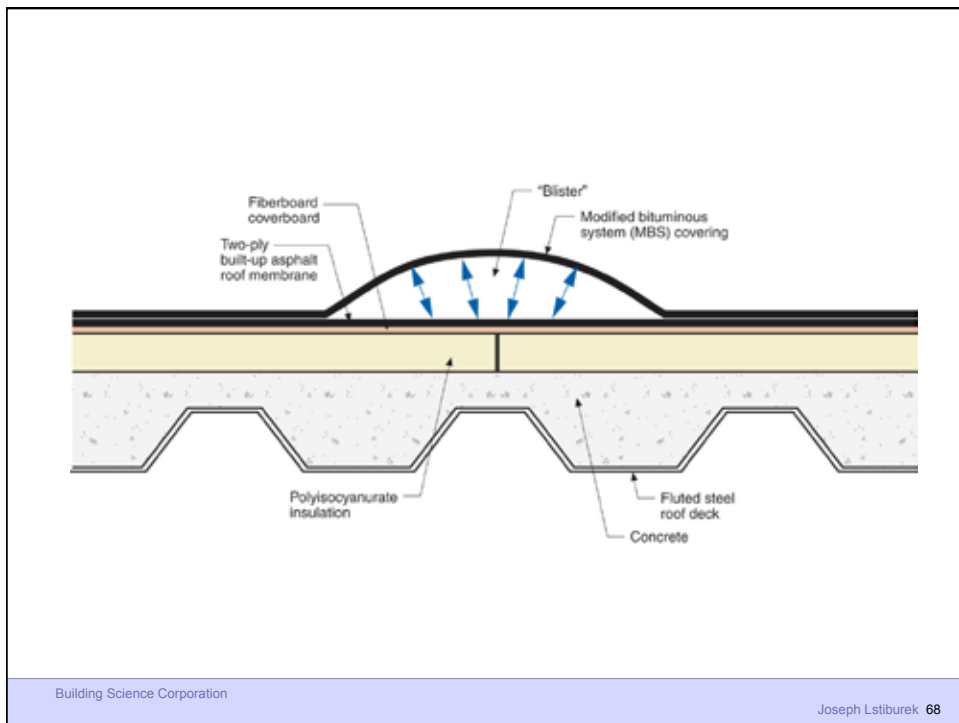
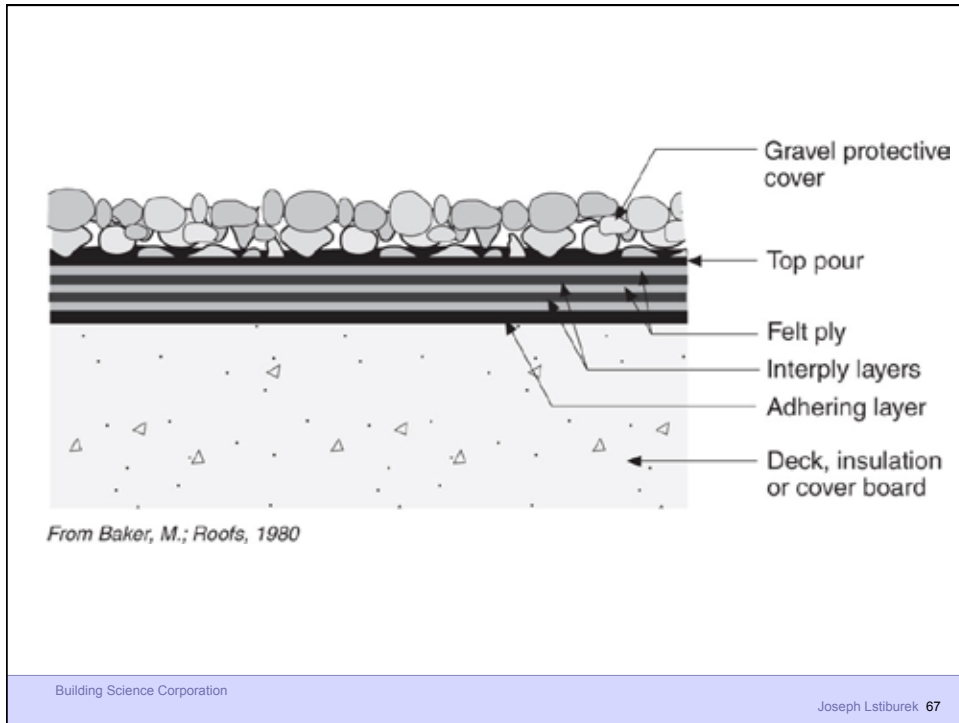

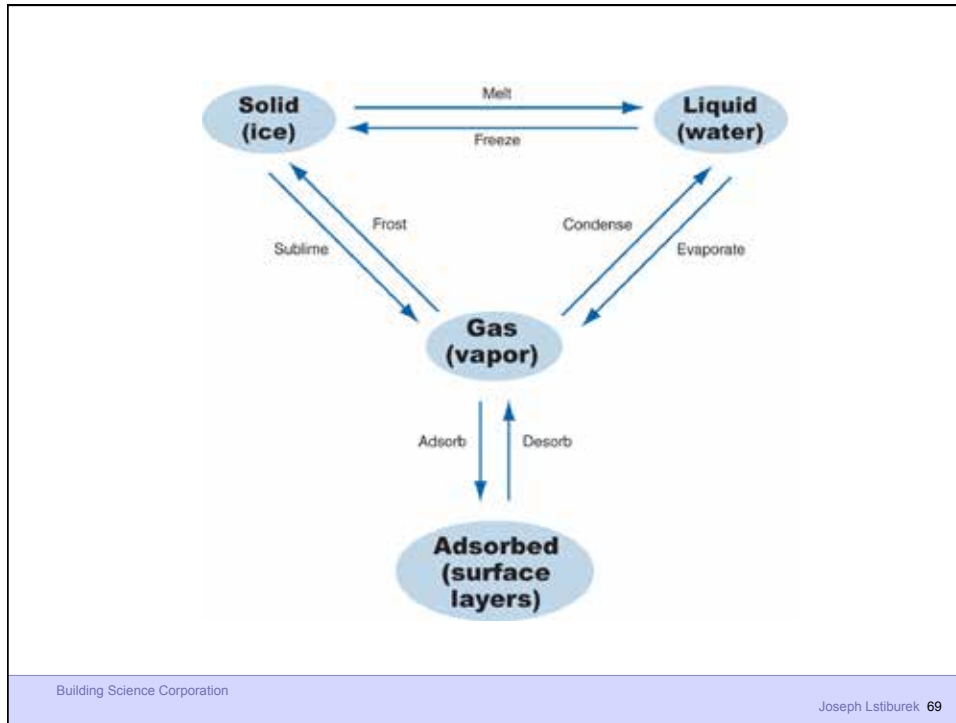

Moisture Transport in Porous Media

Phase	Transport Process	Driving Potential
Vapor	Diffusion	Vapor Concentration
Adsorbate	Surface Diffusion	Concentration
Liquid	Capillary Flow Osmosis	Suction Pressure Solute Concentration

Building Science Corporation Joseph Lstiburek 70

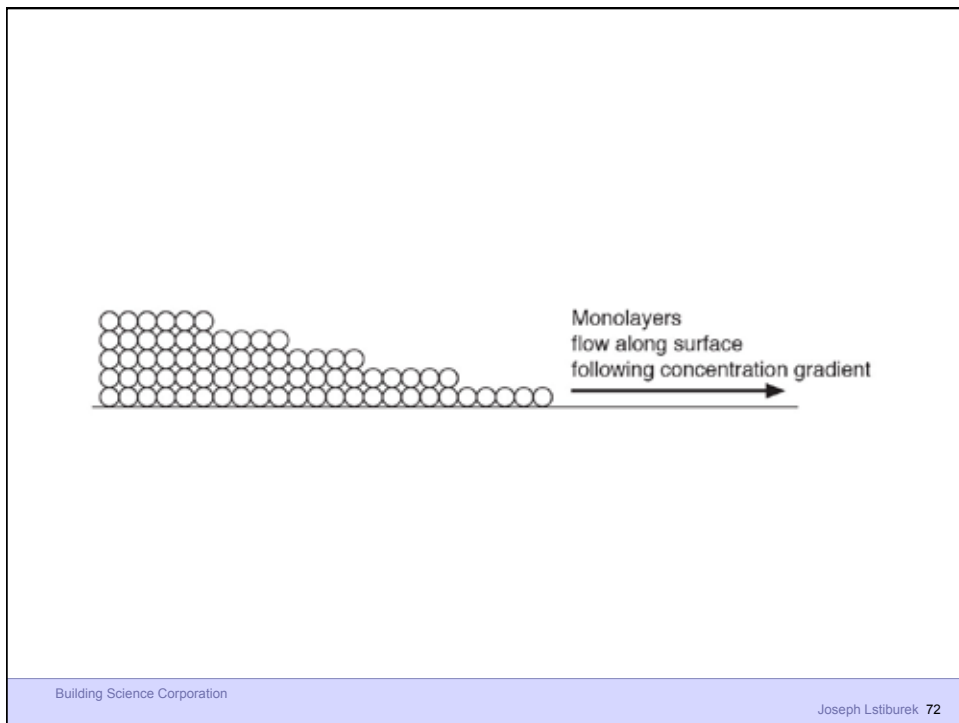
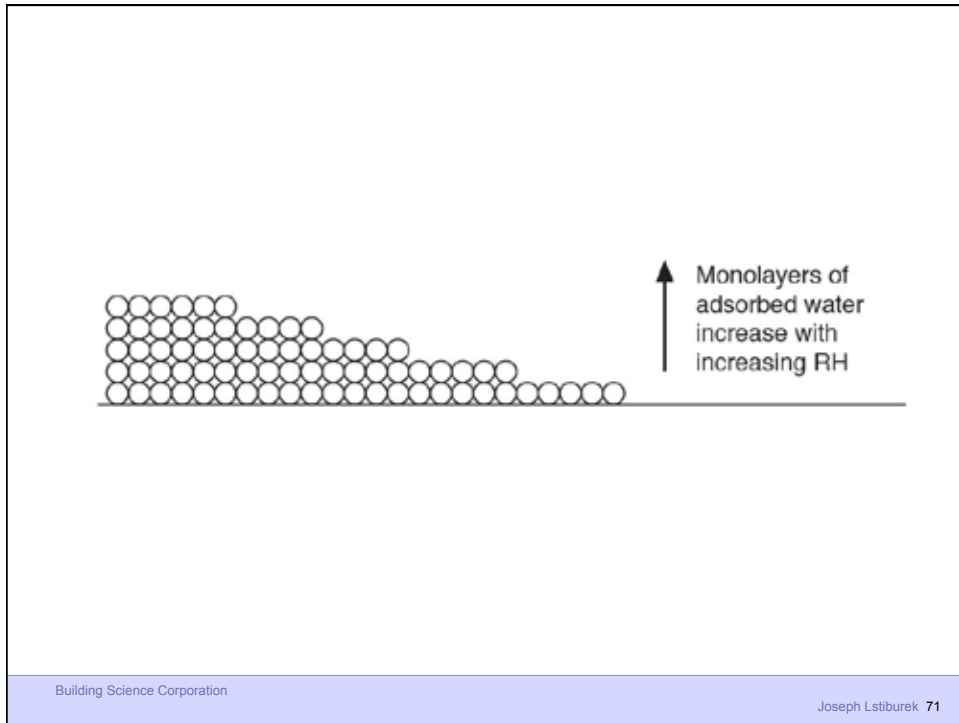

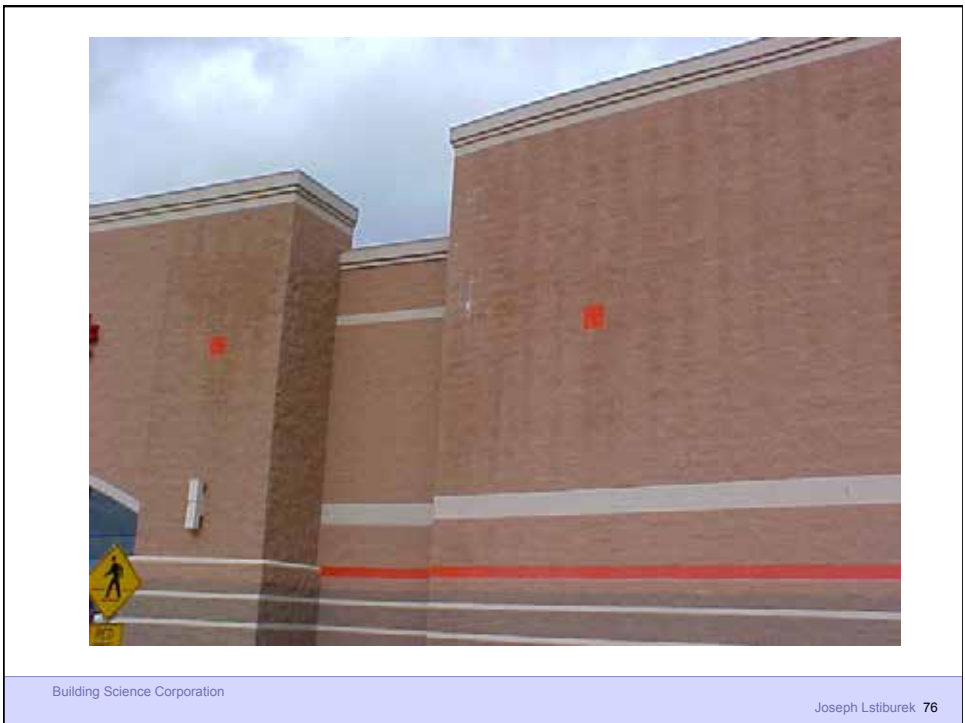
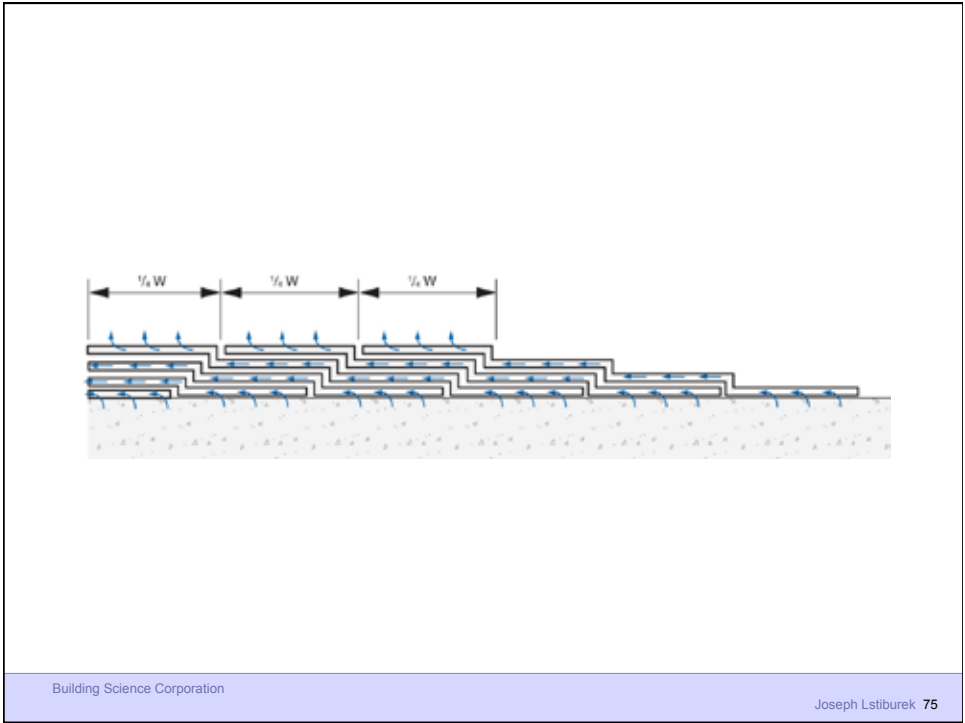



Building Science Corporation

Joseph Lstiburek 77



Building Science Corporation

Joseph Lstiburek 78

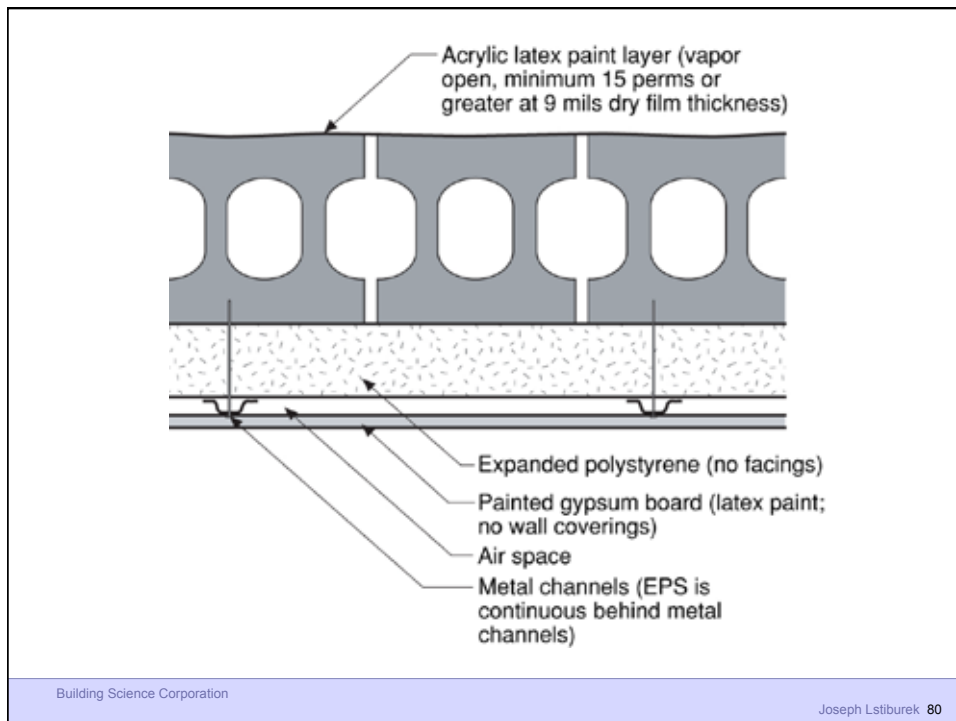
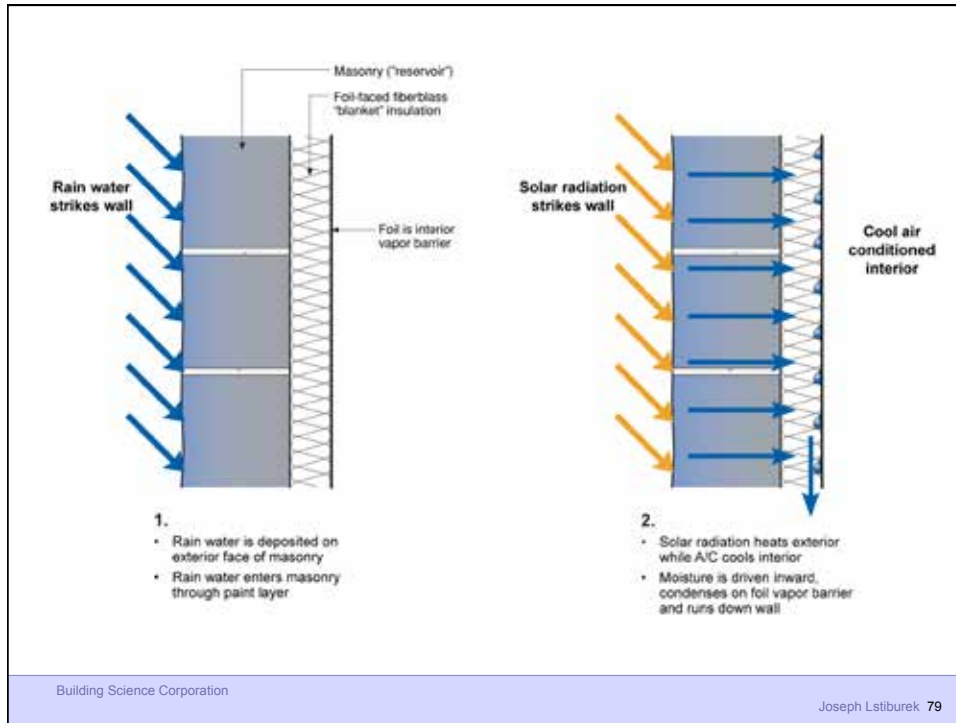

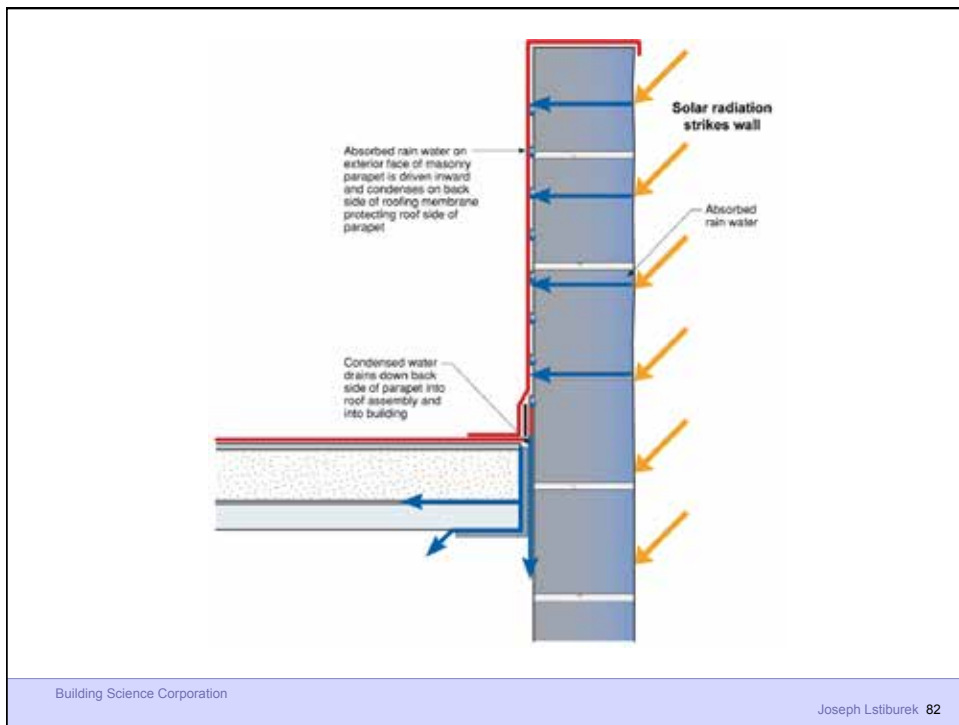
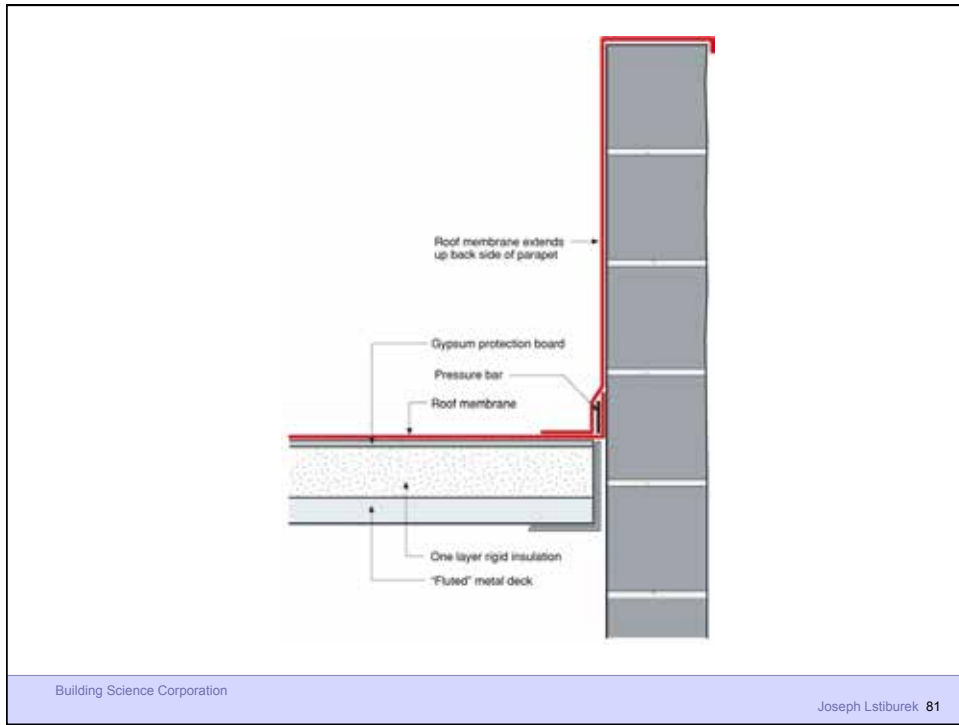

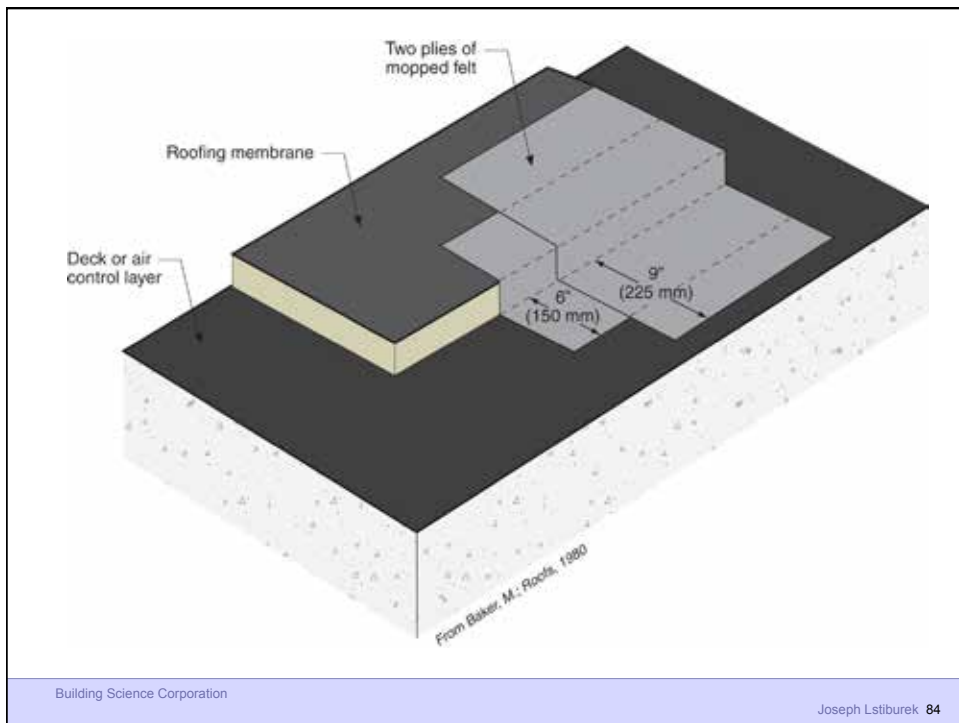
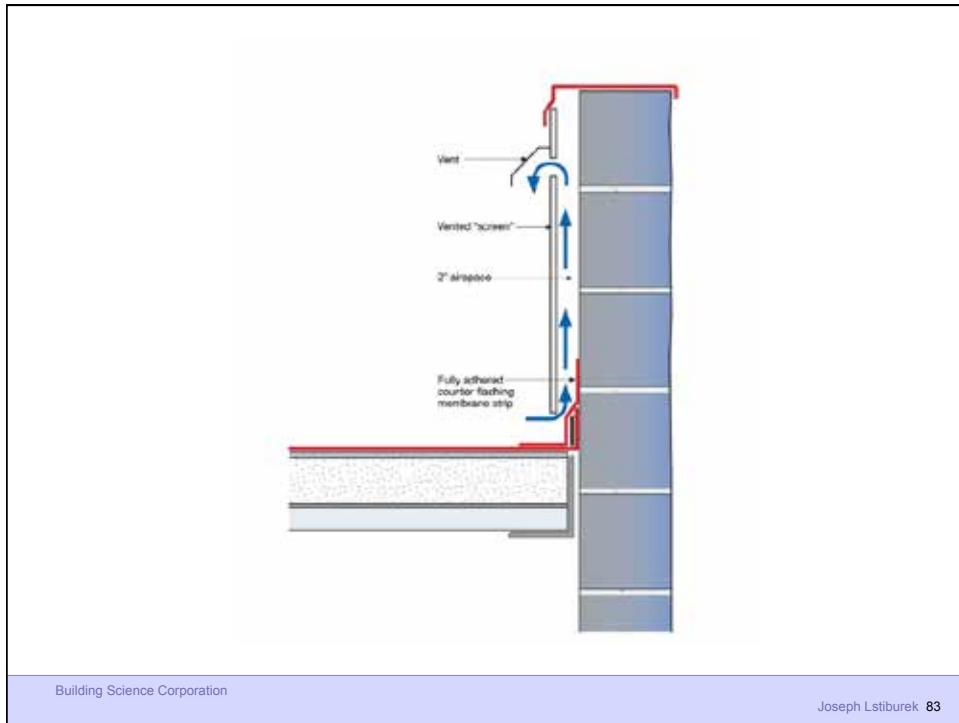

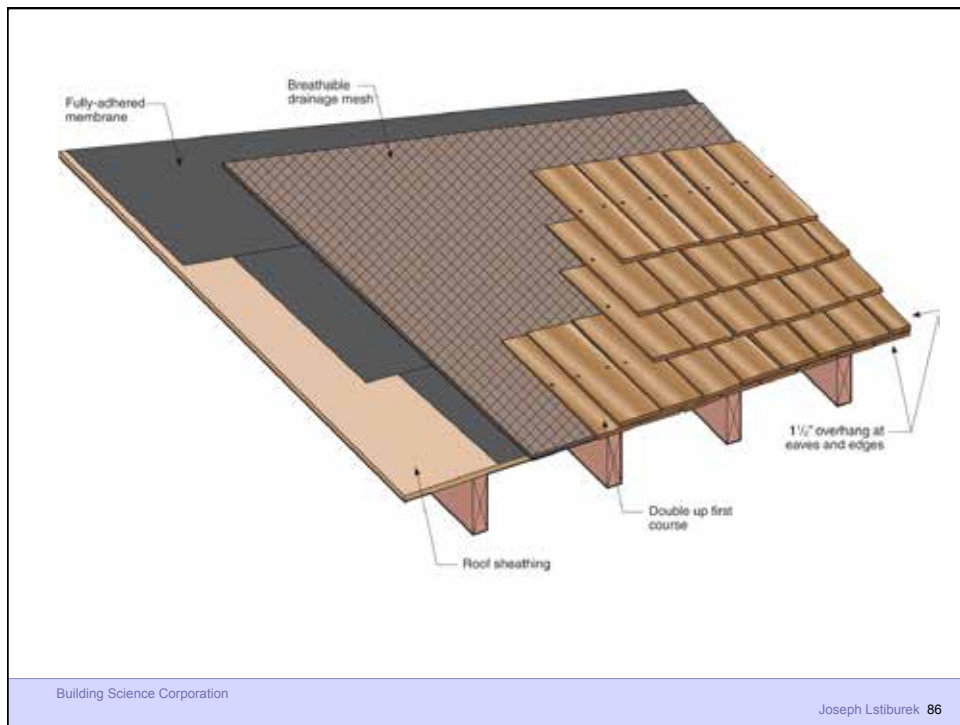
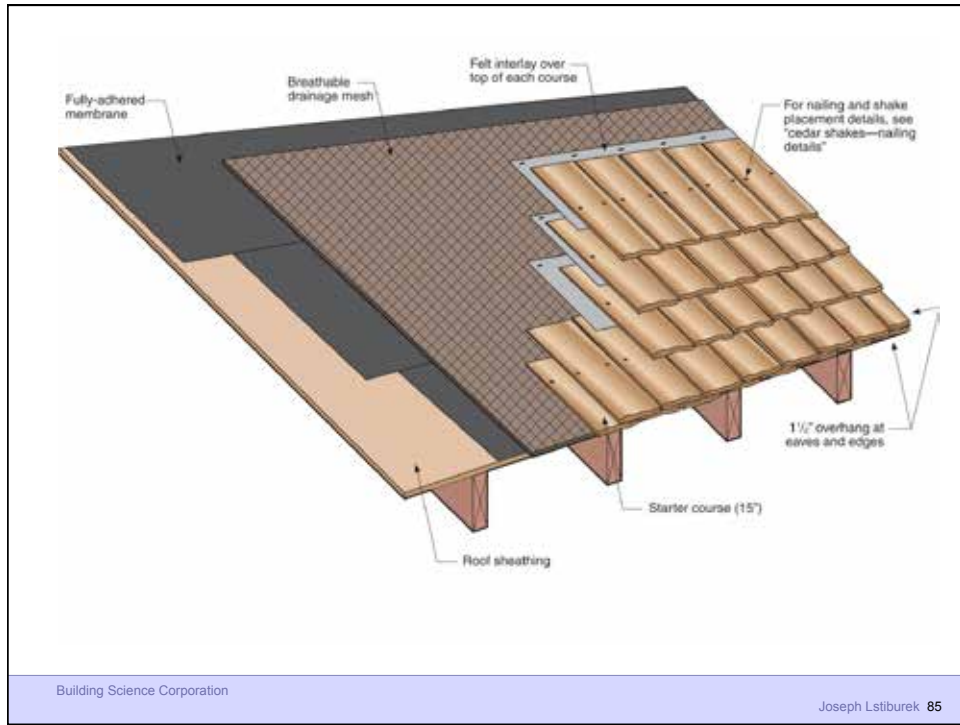

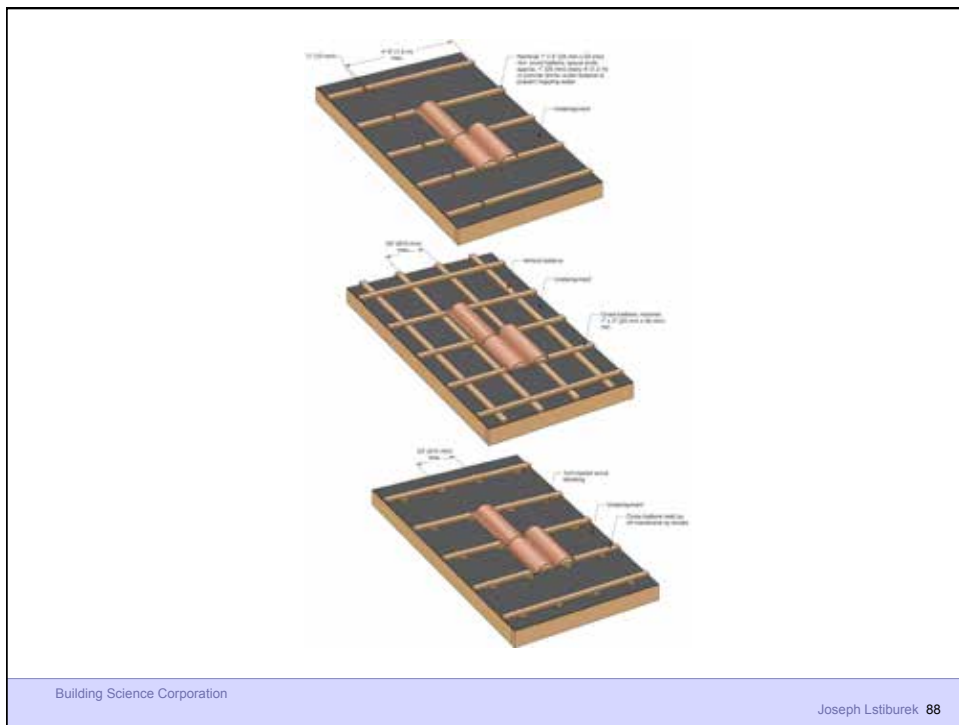
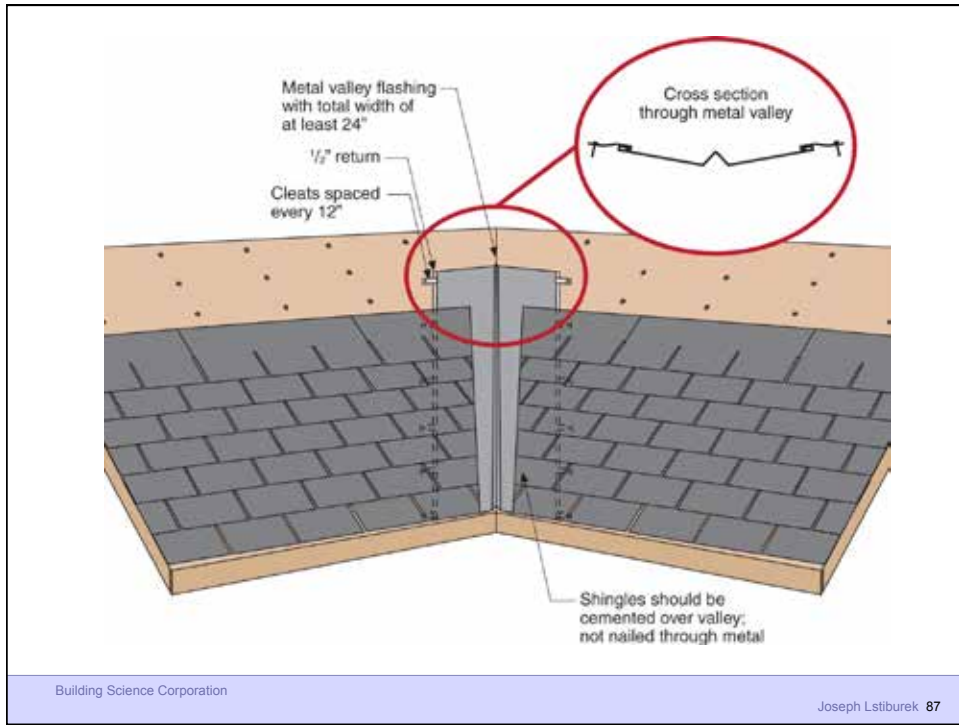

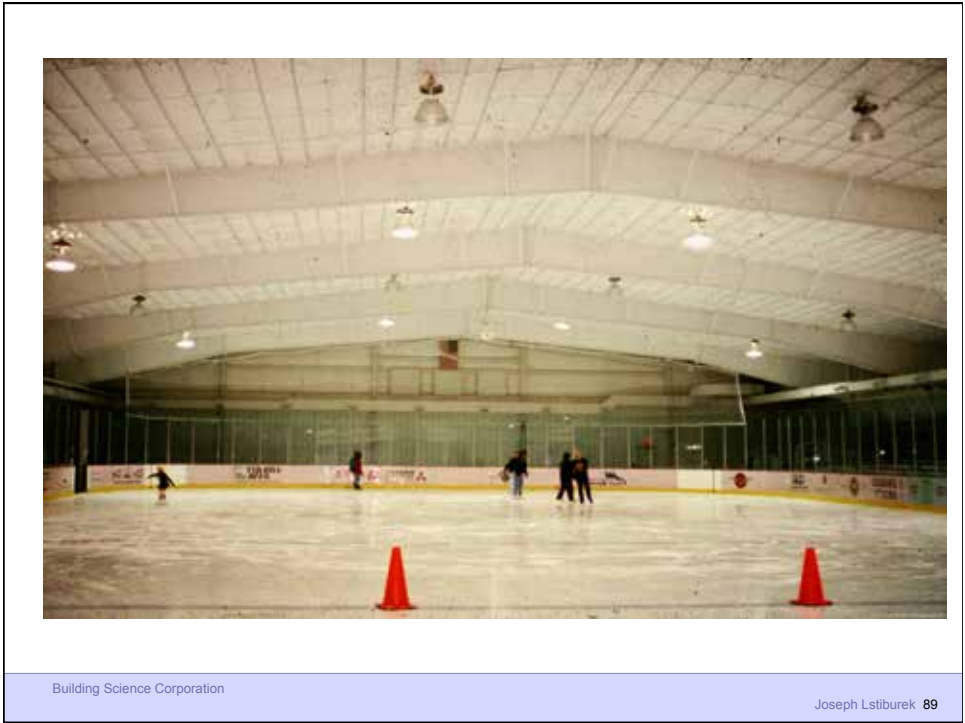



Building Science Corporation

Joseph Lstiburek 91

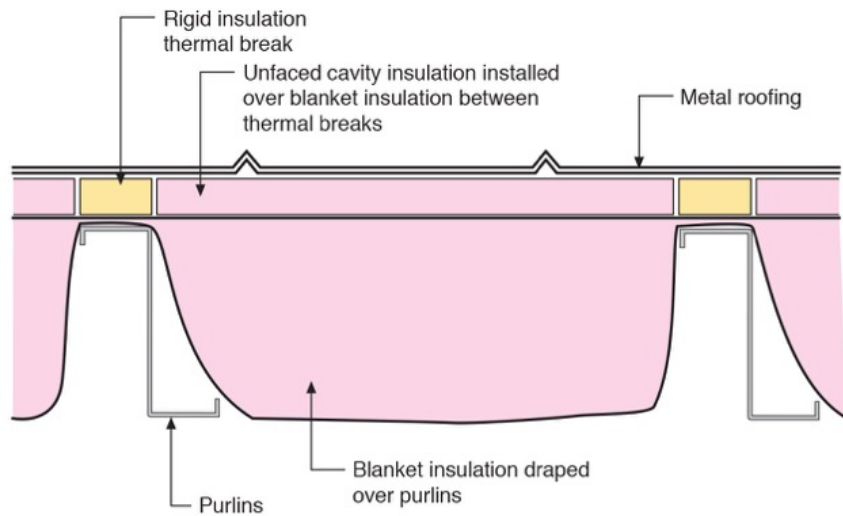

Blanket Insulation Purlin Roof System

Building Science Corporation

Joseph Lstiburek 92





Building Science Corporation

Joseph Lstiburek 95



Building Science Corporation

Joseph Lstiburek 96

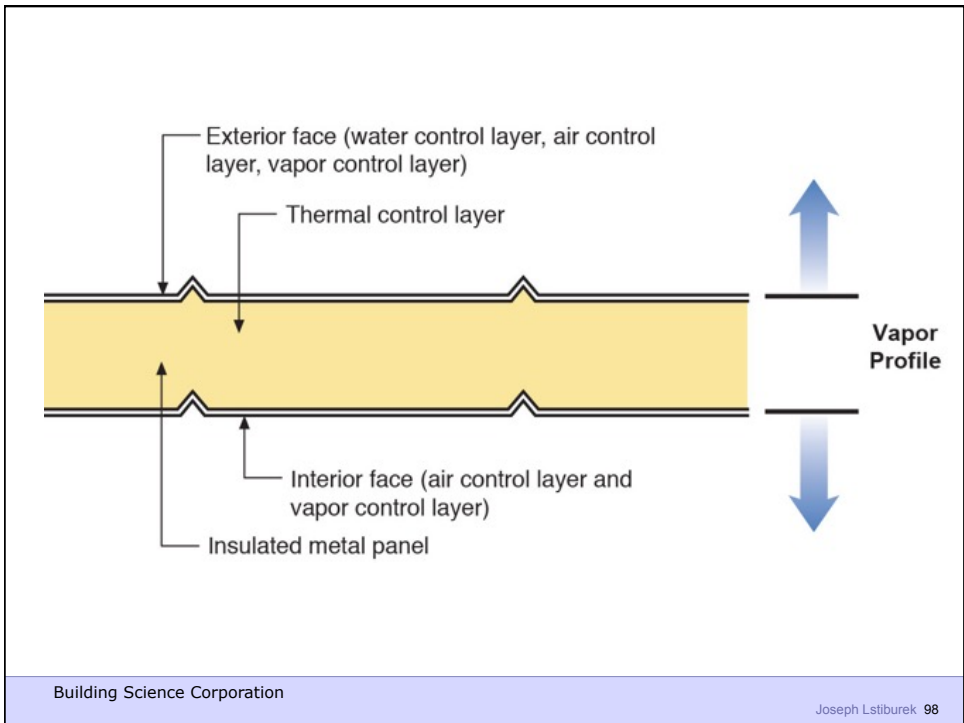

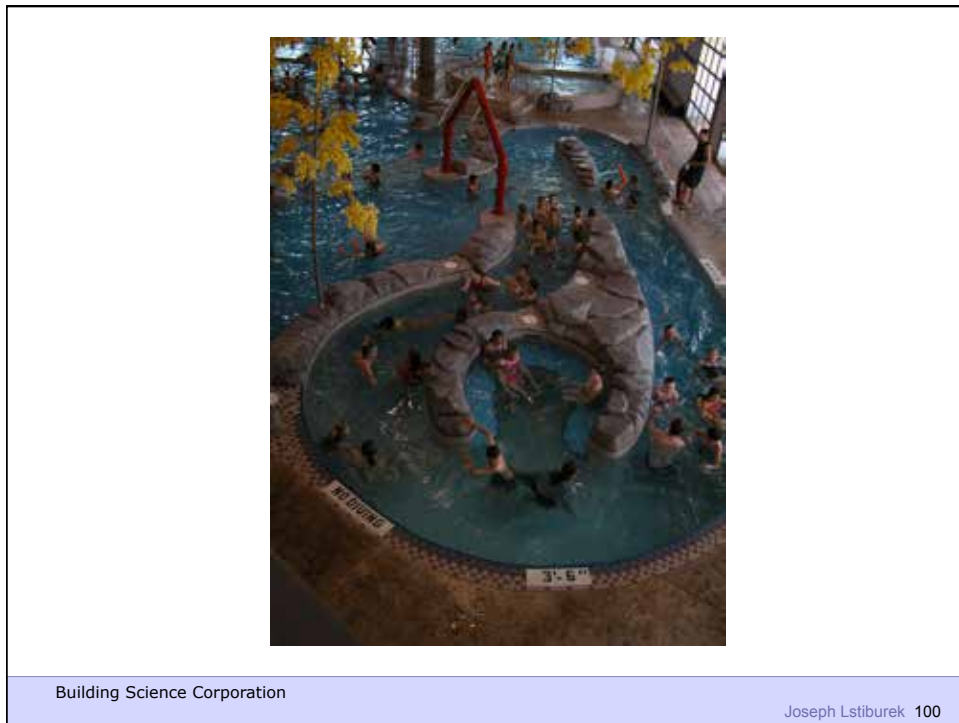
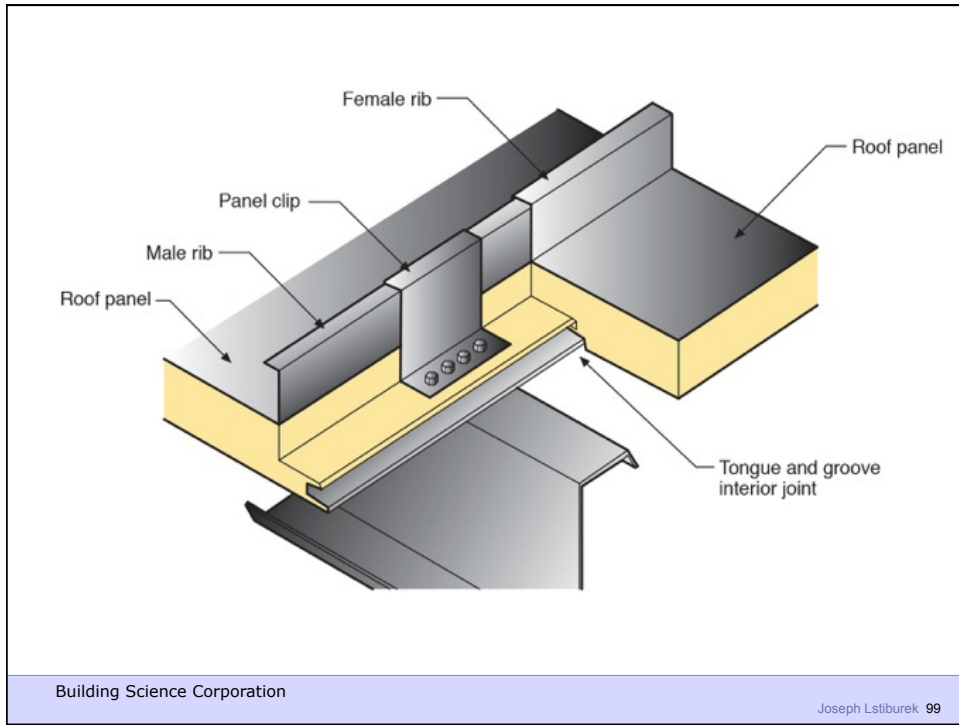

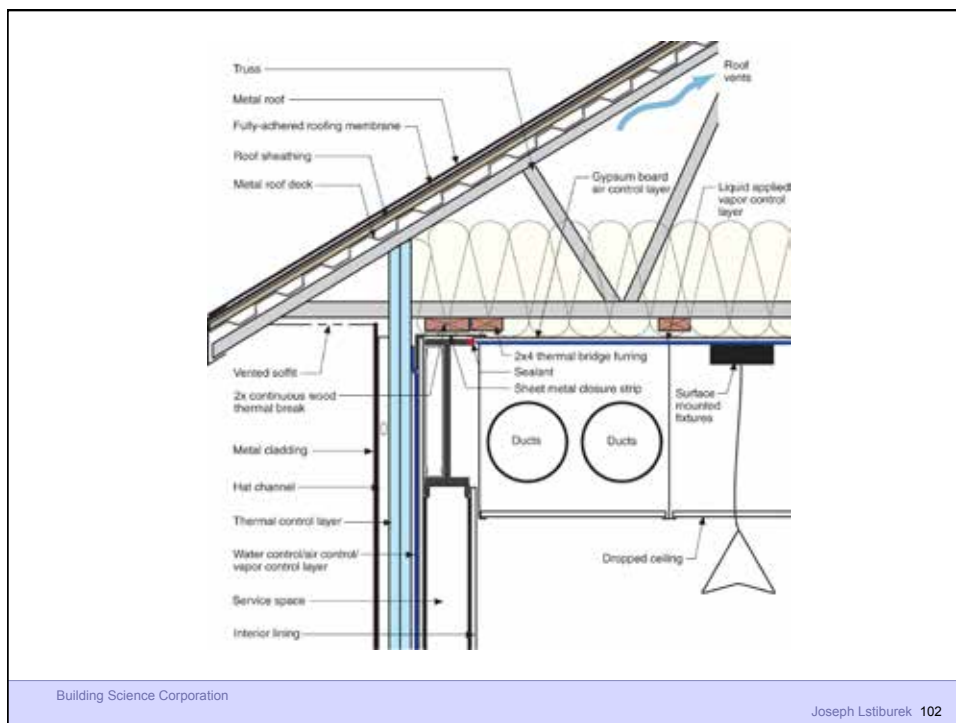
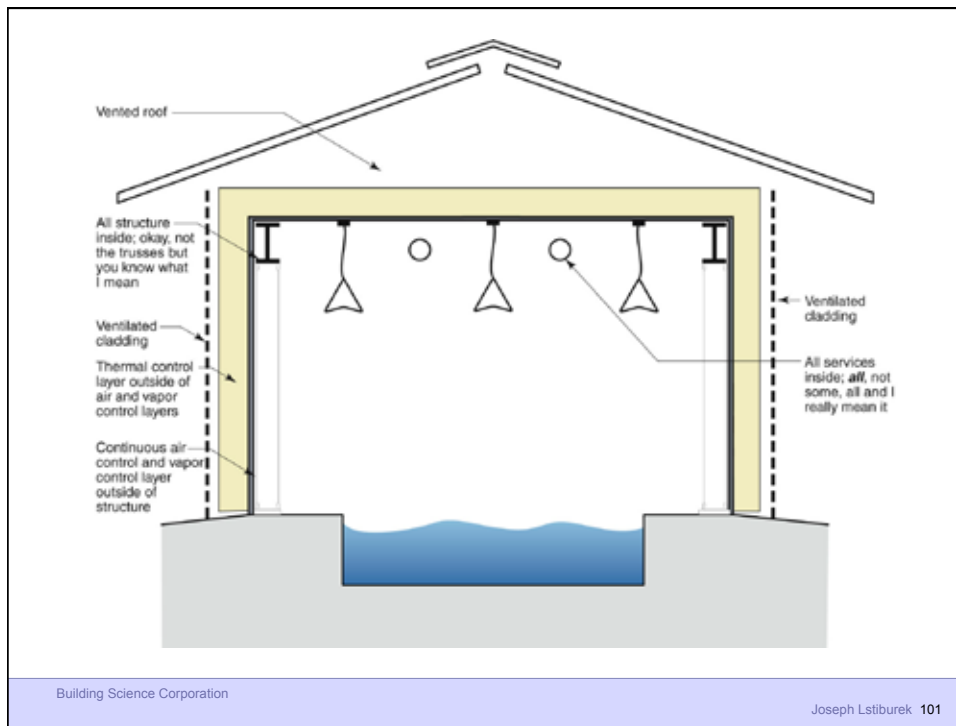

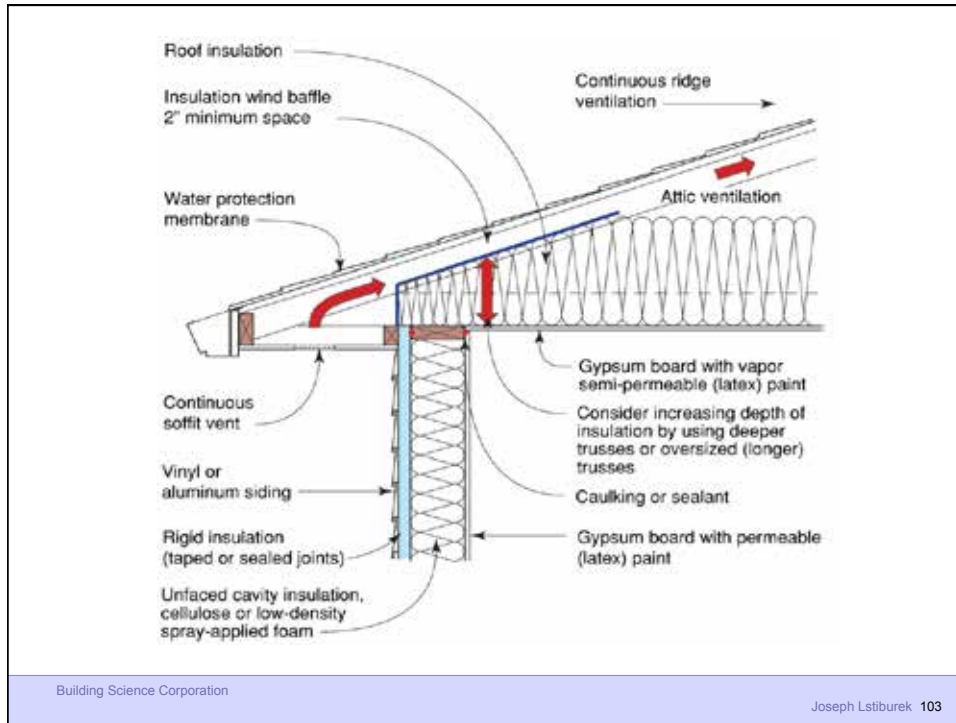

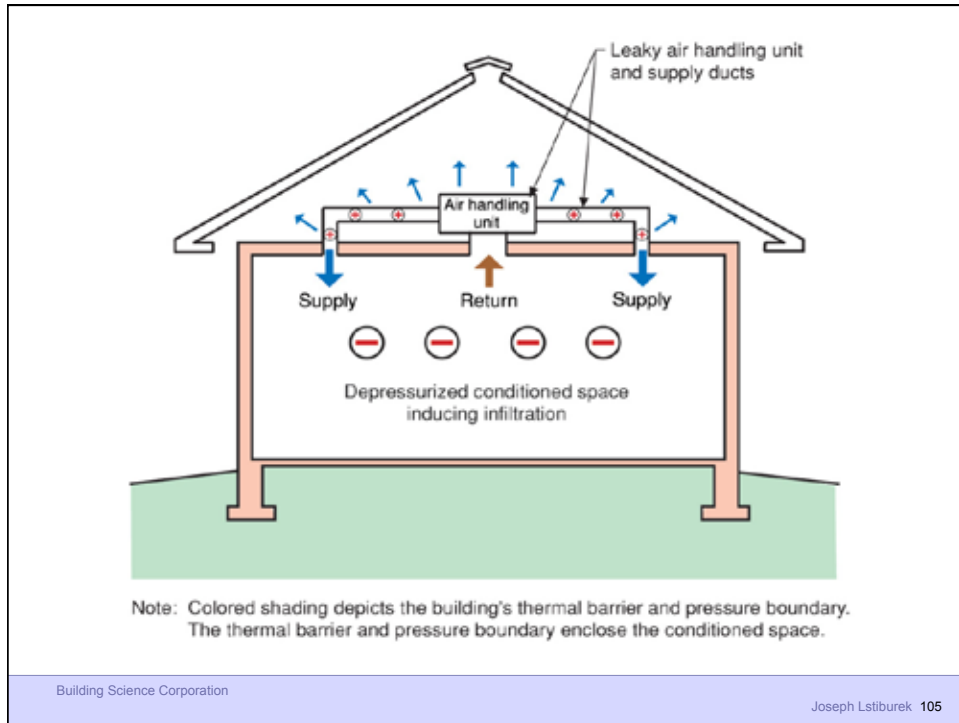

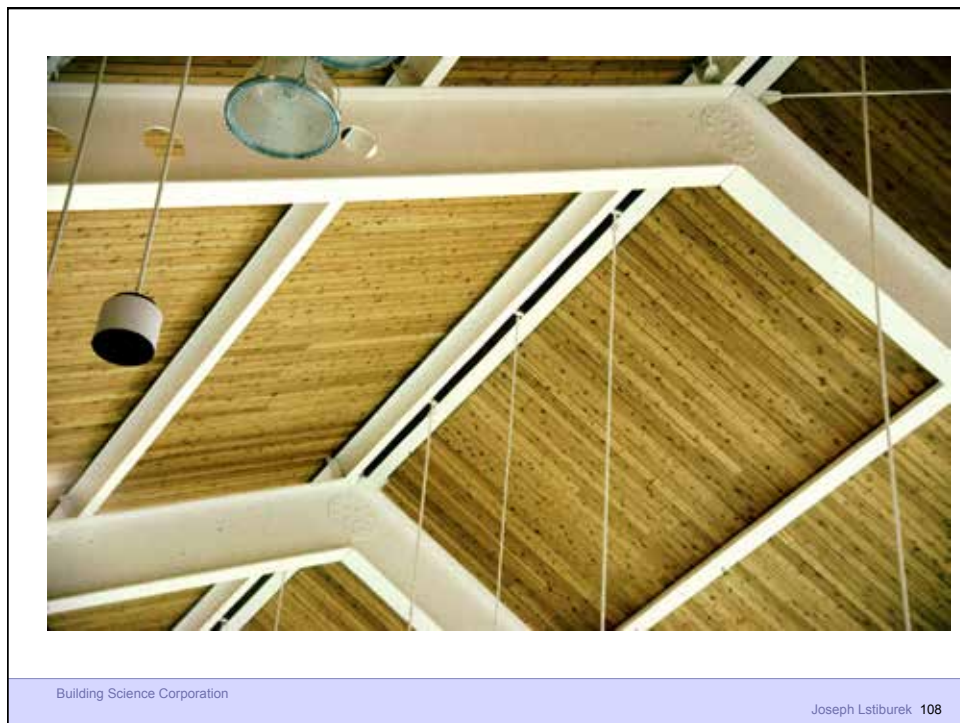
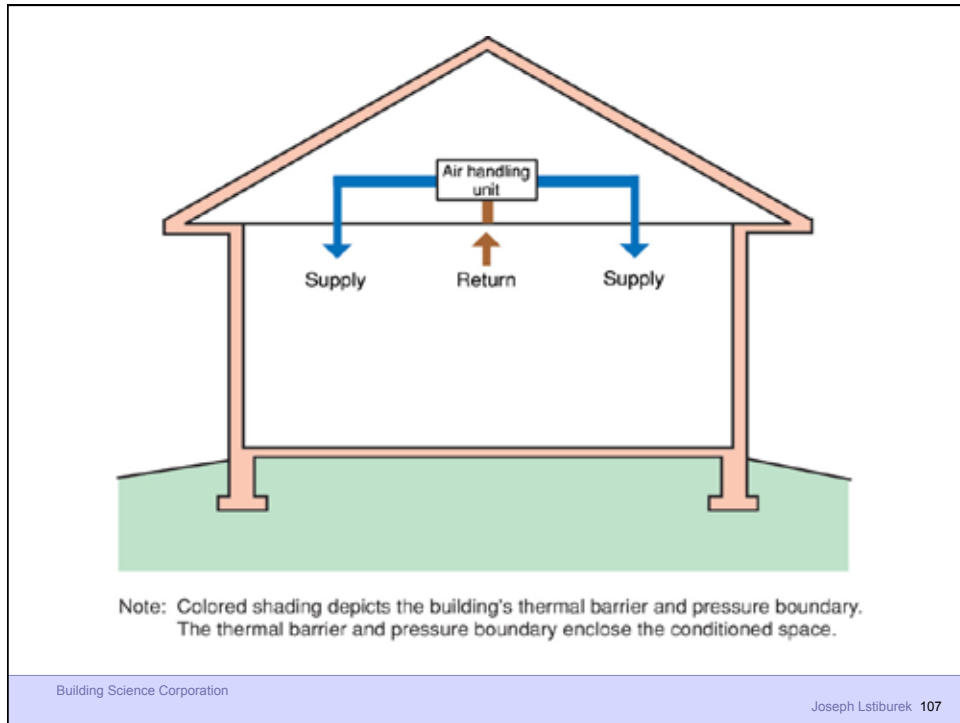

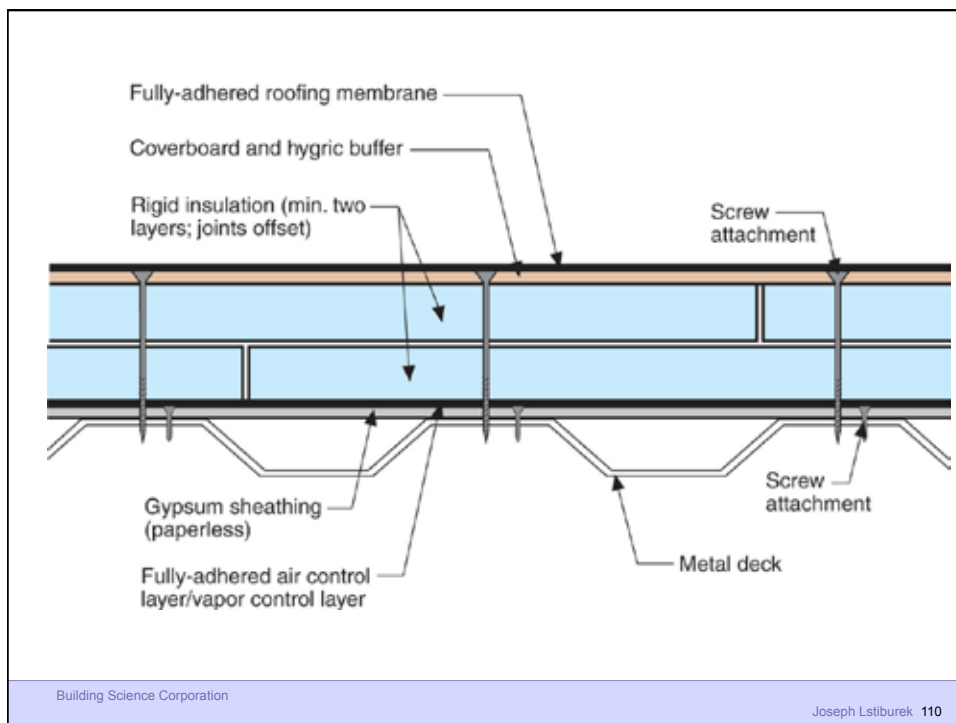
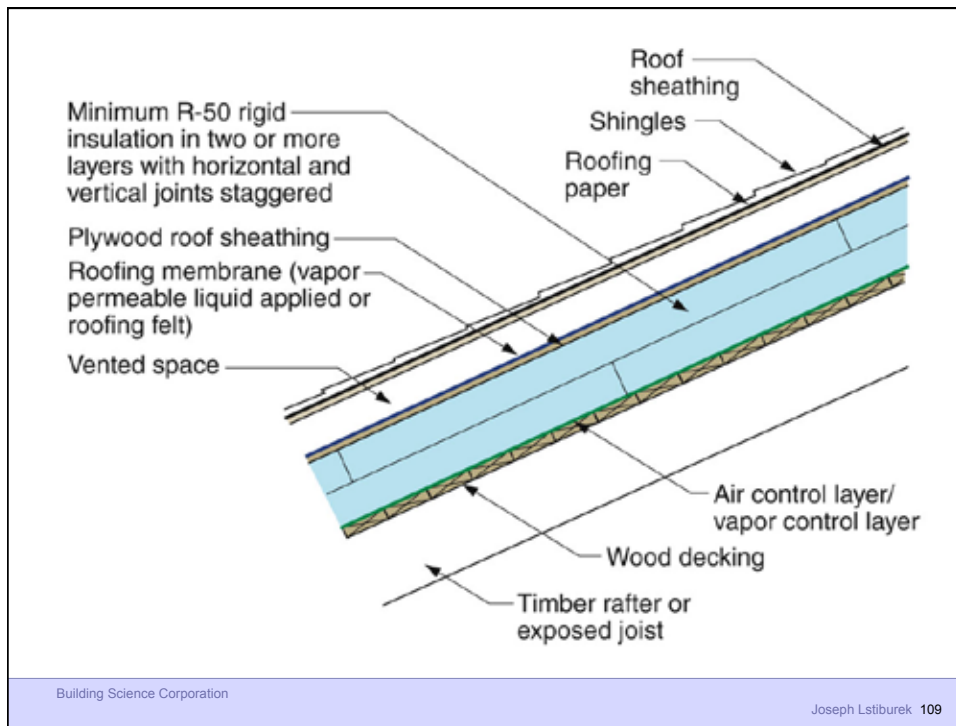

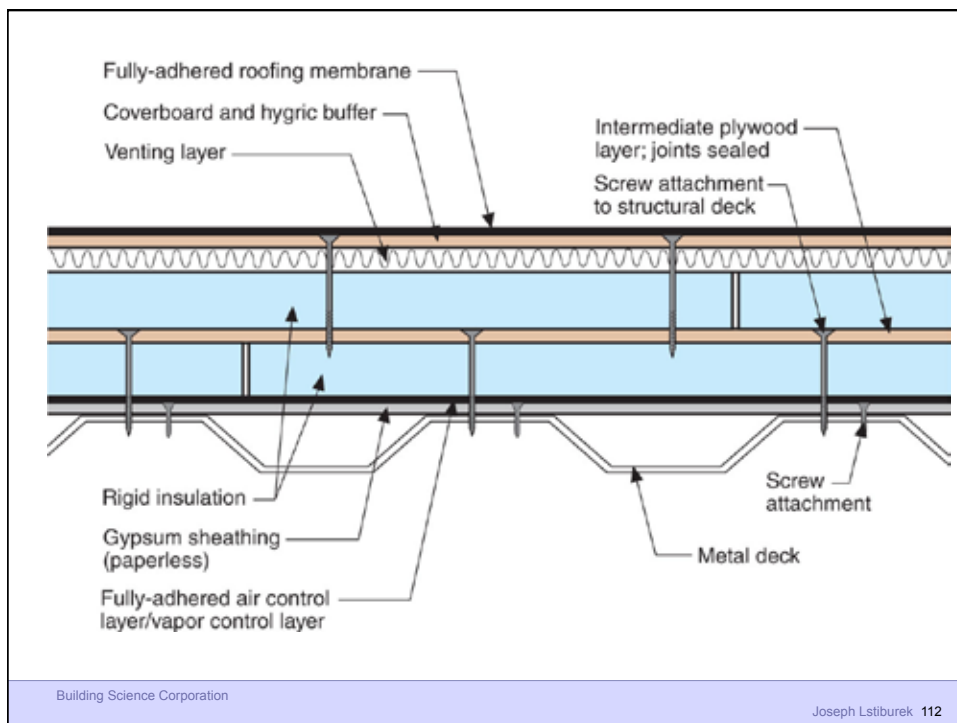
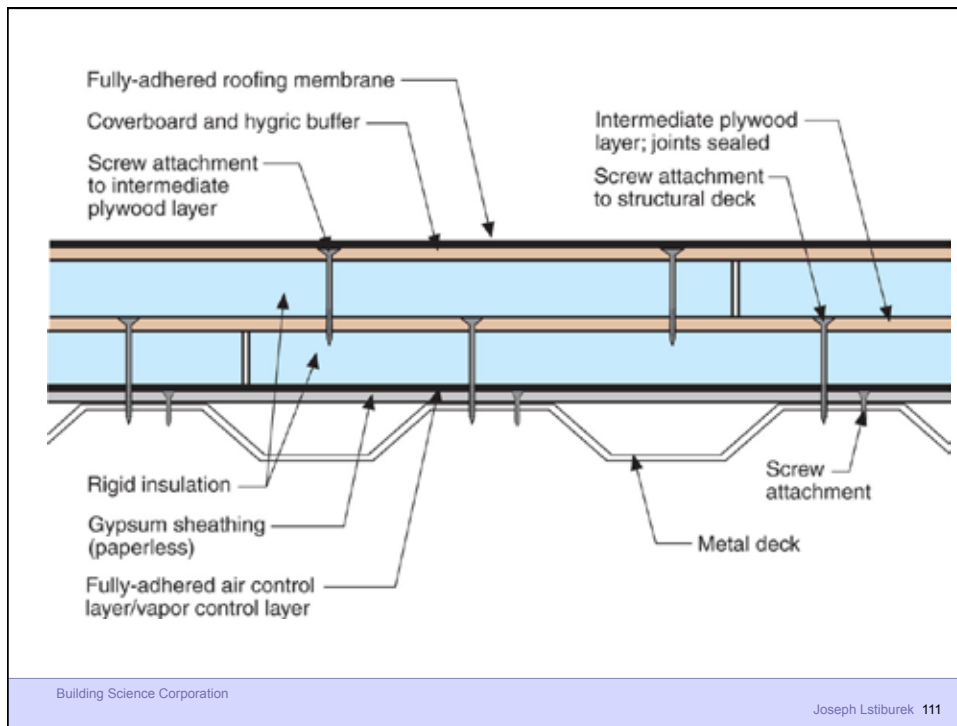



Building Science Corporation

Joseph Lstiburek 113



Building Science Corporation

Joseph Lstiburek 114

