

Joseph Lstiburek, Ph.D., P.Eng, ASHRAE Fellow

## Building Science

North American Wood Window and  
Door Symposium

[www.buildingscience.com](http://www.buildingscience.com)

Life is Tough Enough As it Is...

Building Science Corporation

Joseph Lstiburek 2

Life is Tough Enough As it Is...  
It's Harder When You Are Stupid

Building Science Corporation

Joseph Lstiburek 3

Don't Do Stupid Things

Building Science Corporation

Joseph Lstiburek 4

## What is a Building?

Building Science Corporation

Joseph Lstiburek 5

Water Control Layer  
Air Control Layer  
Vapor Control Layer  
Thermal Control Layer

Building Science Corporation

Joseph Lstiburek 6

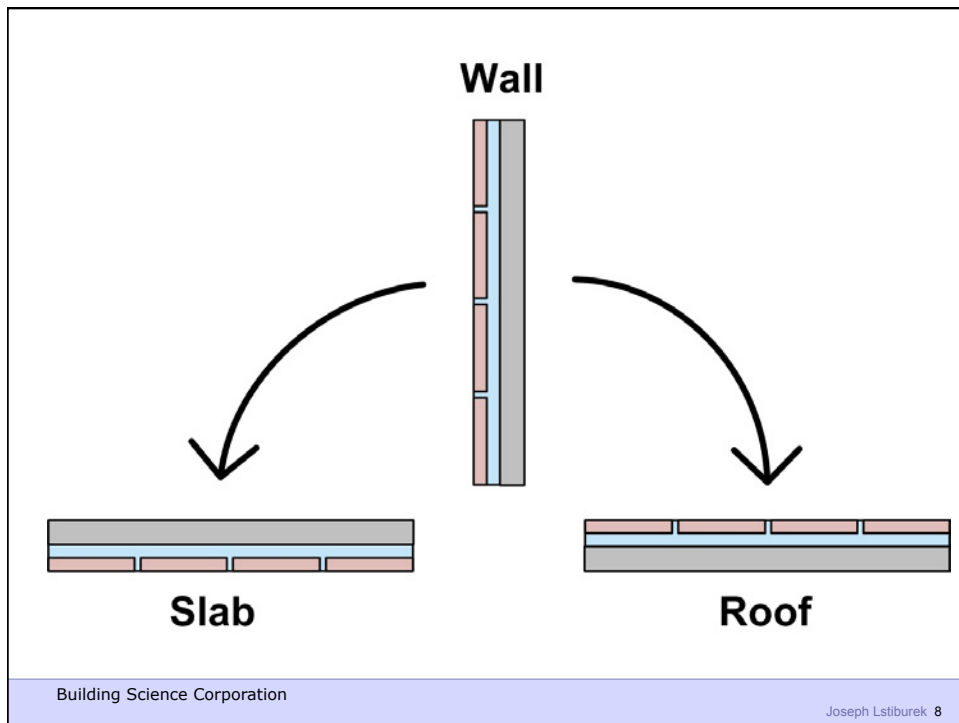
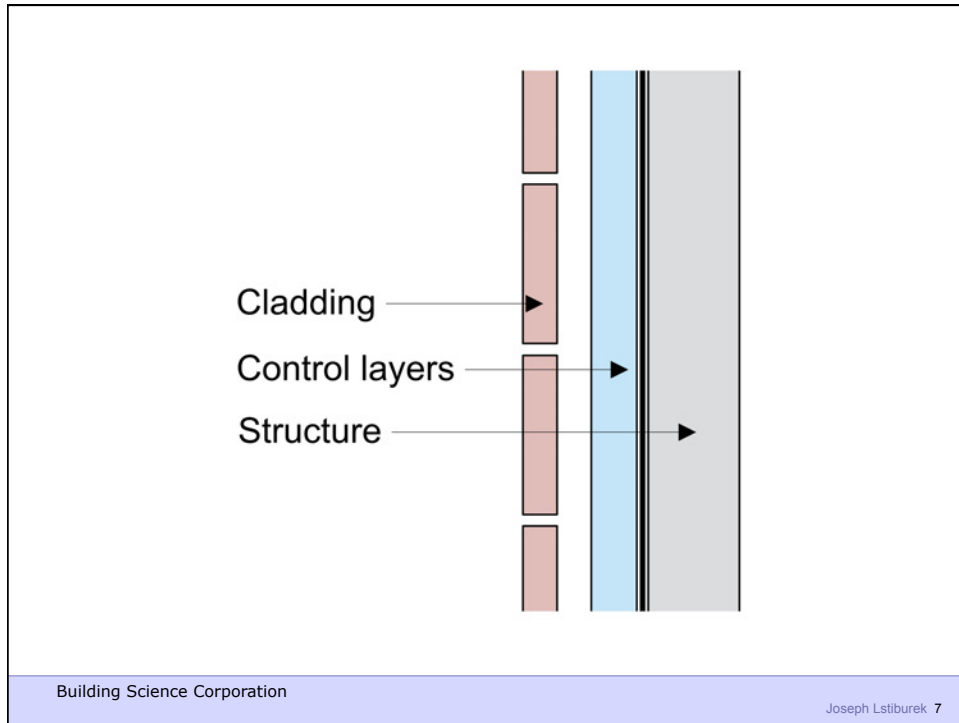

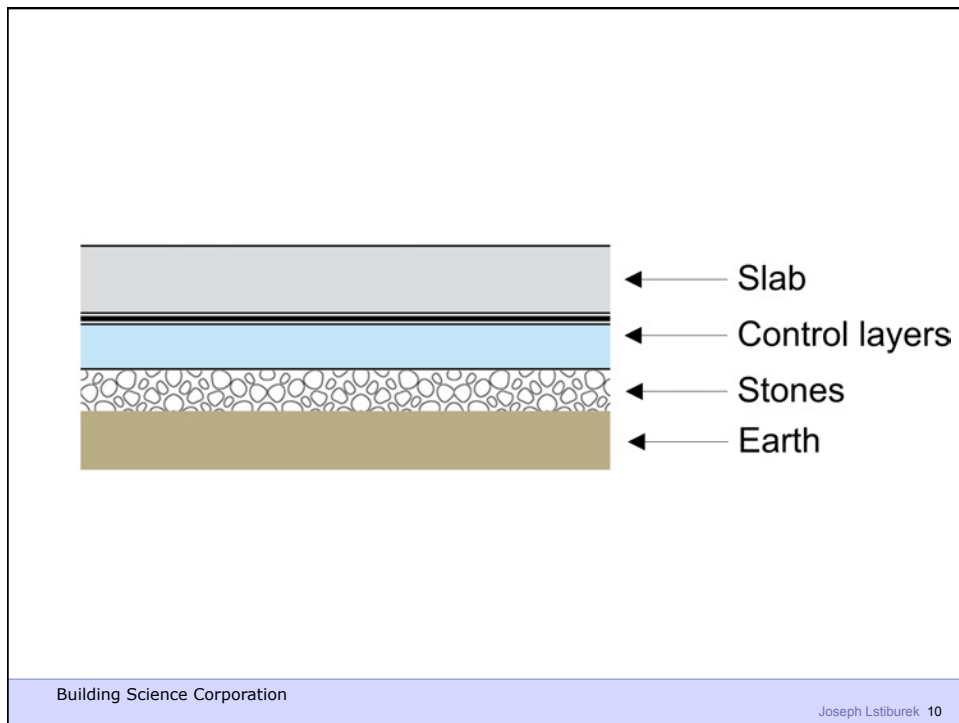
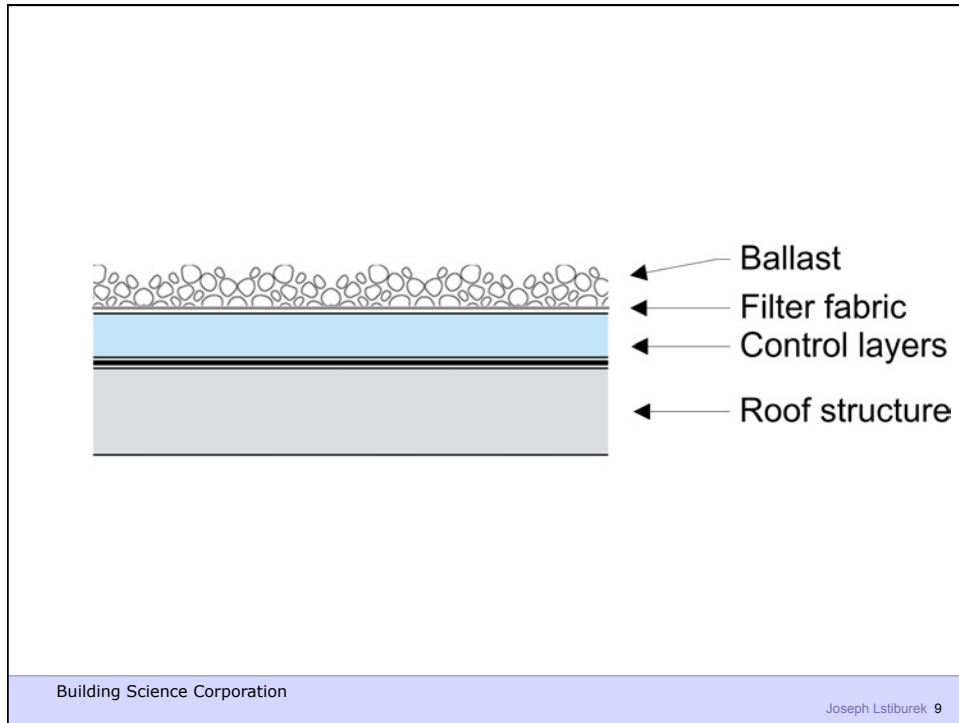

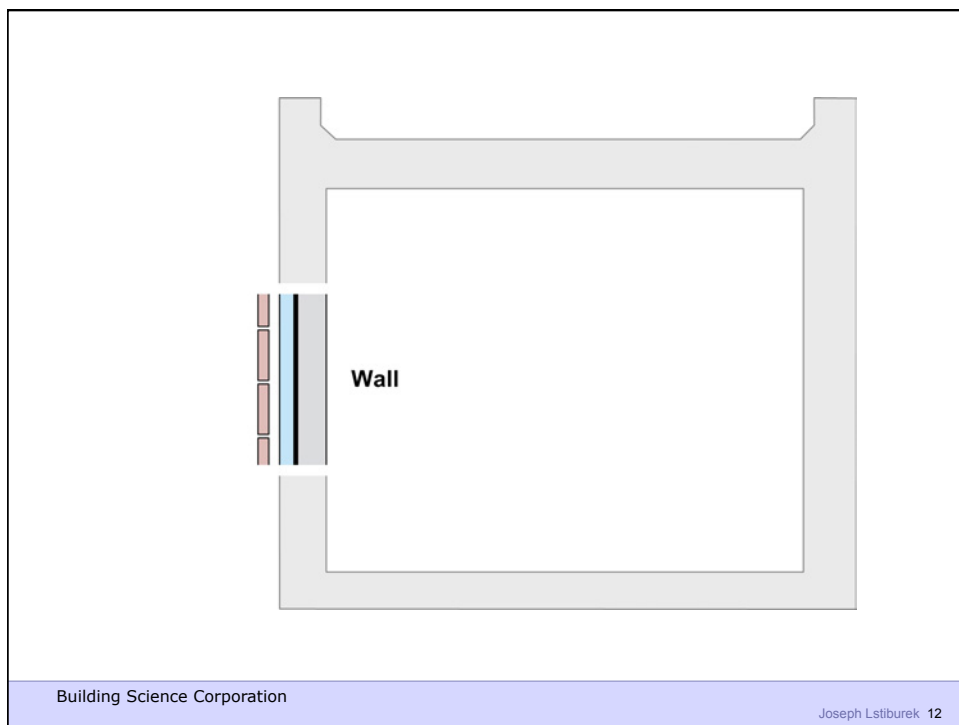
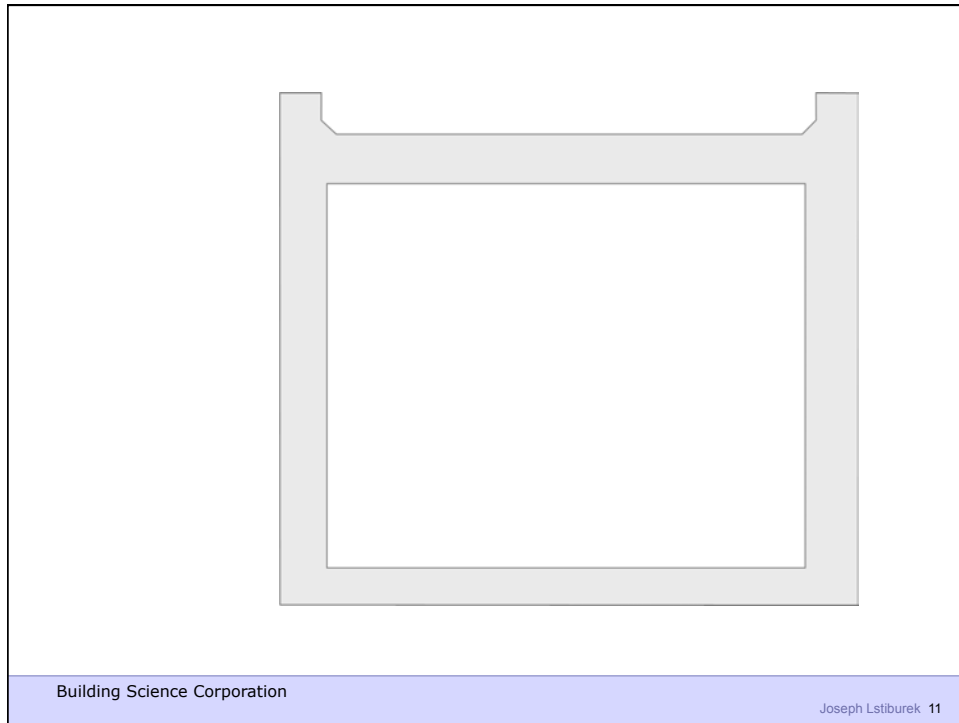

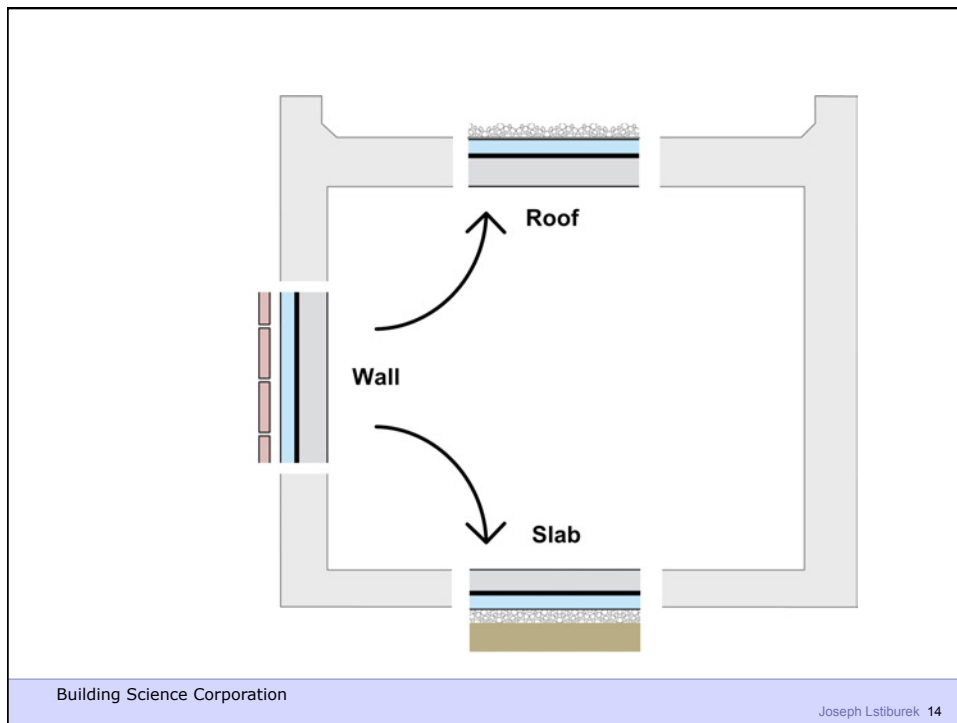
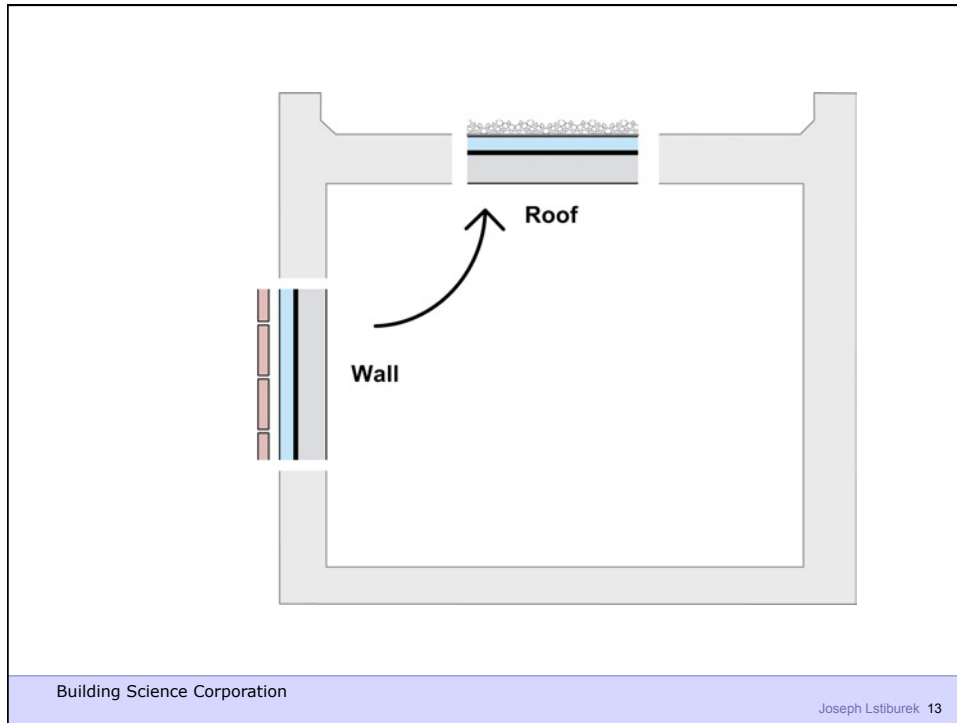

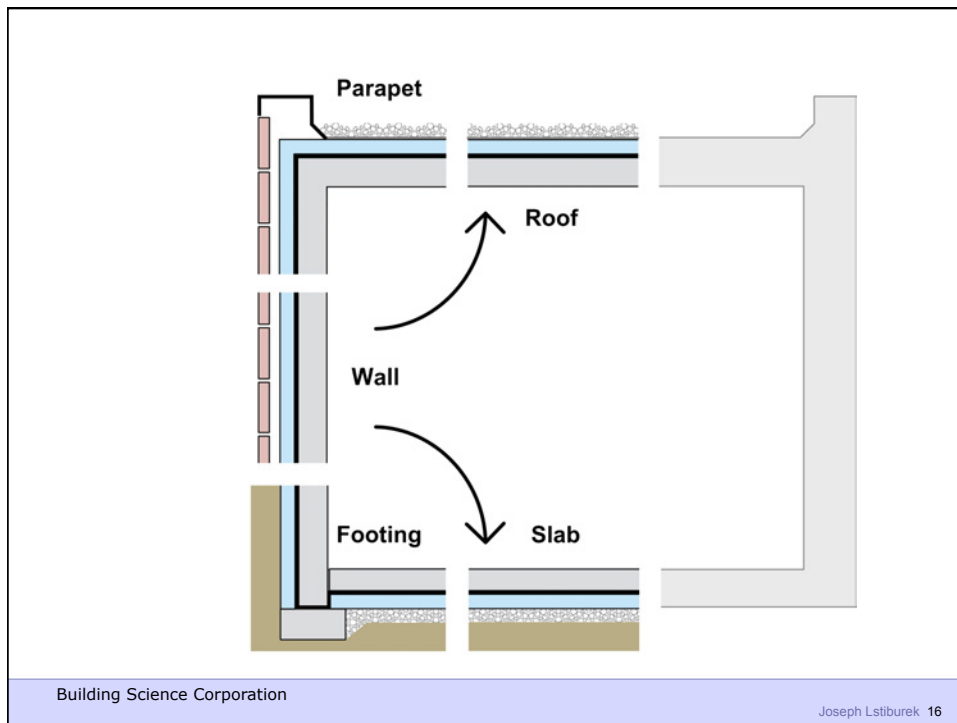
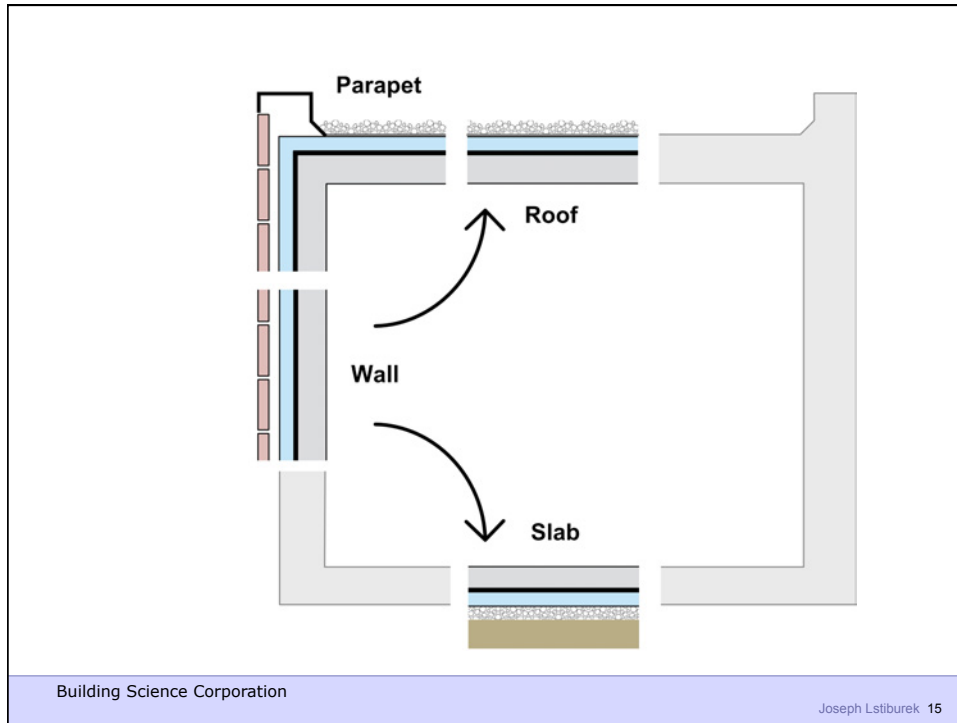



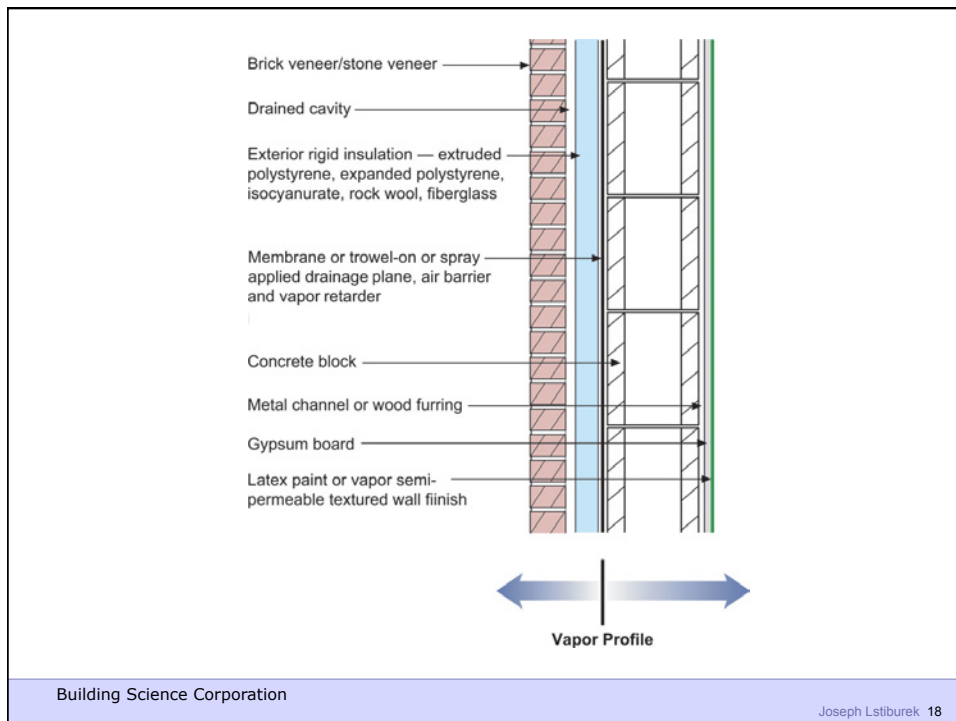
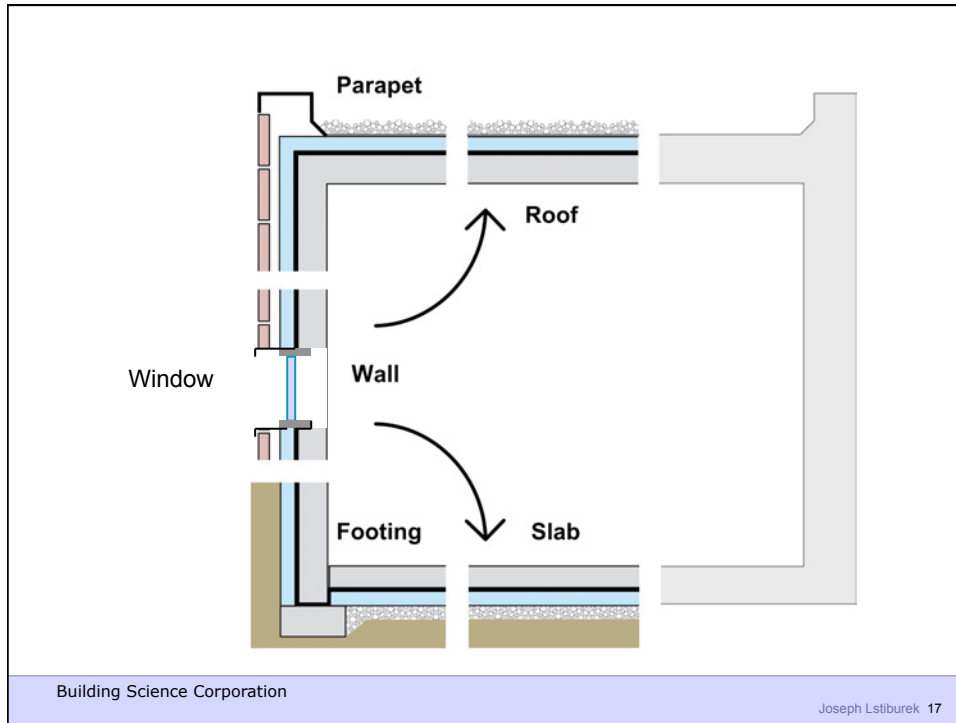

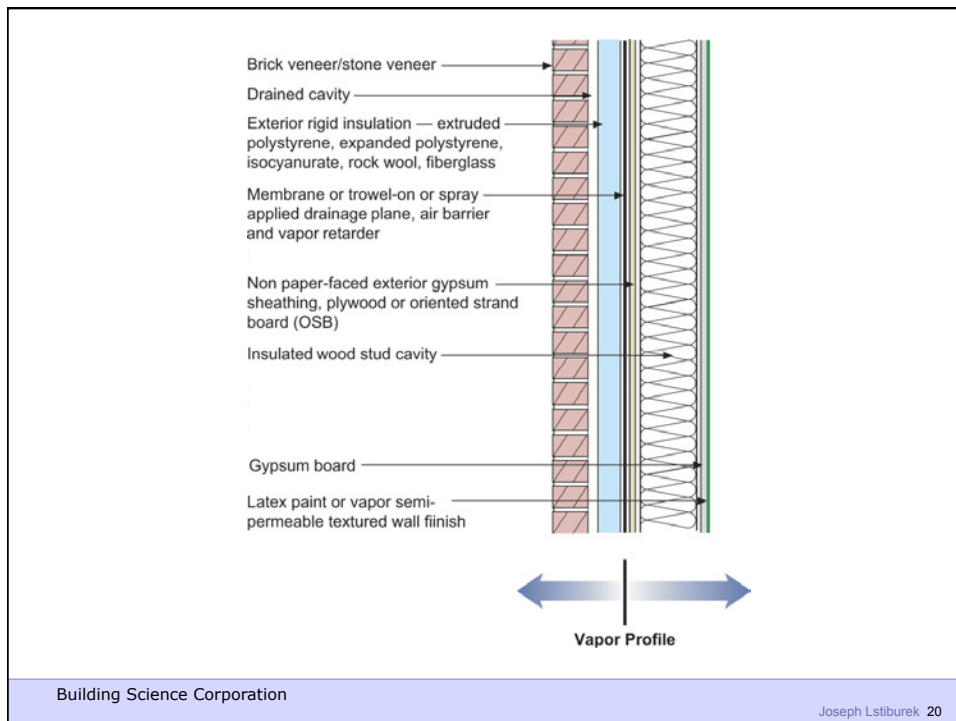
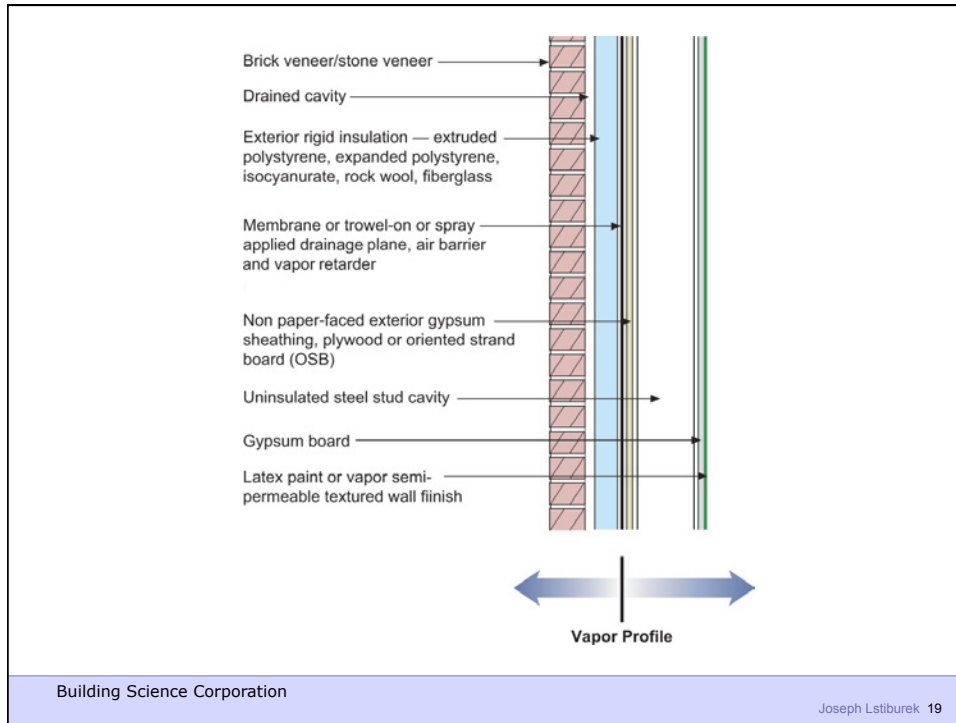

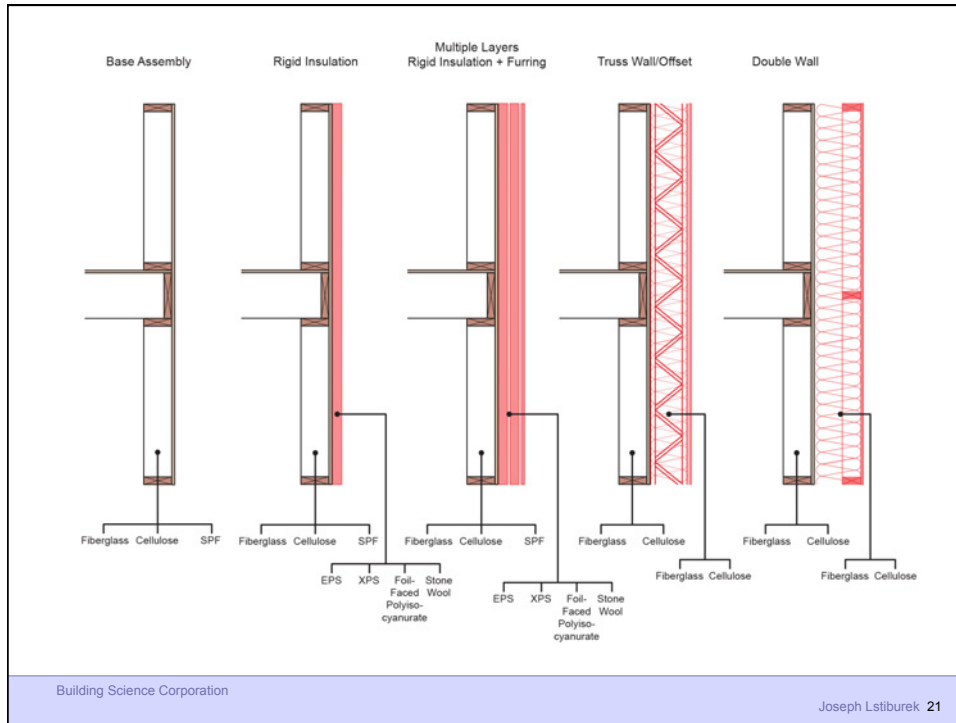





Building Science Corporation

Joseph Lstiburek – Rain Control 25

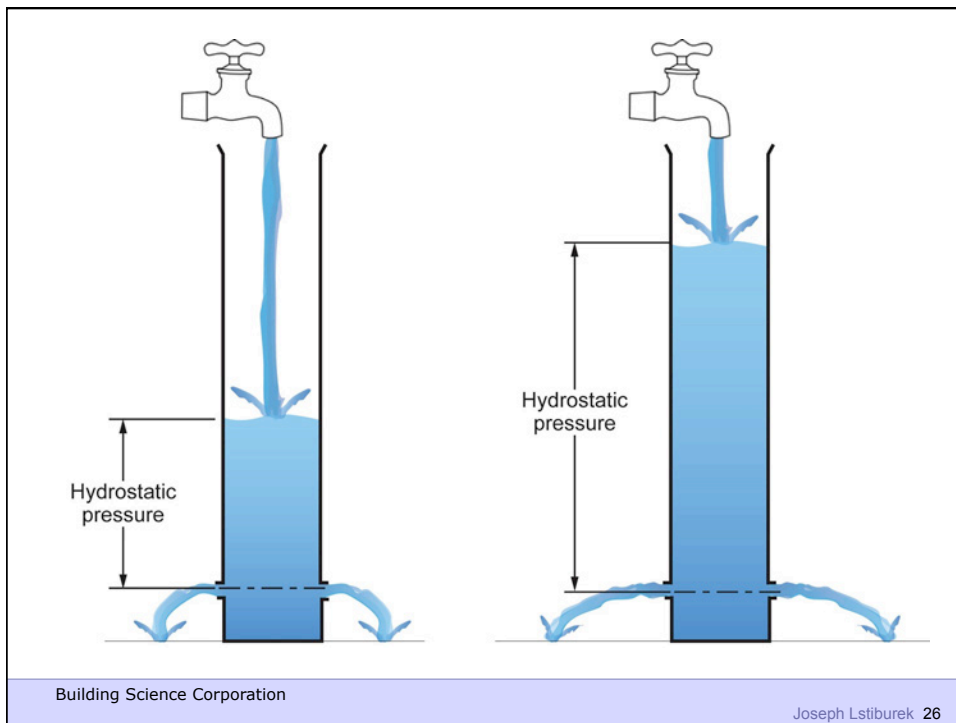

Building Science Corporation

Joseph Lstiburek 26



Building Science Corporation

Joseph Lstiburek 27

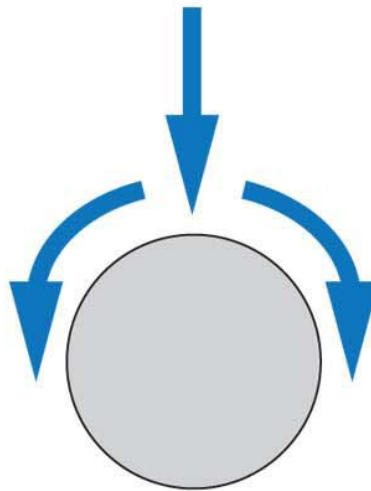

Building Science Corporation

Joseph Lstiburek 28

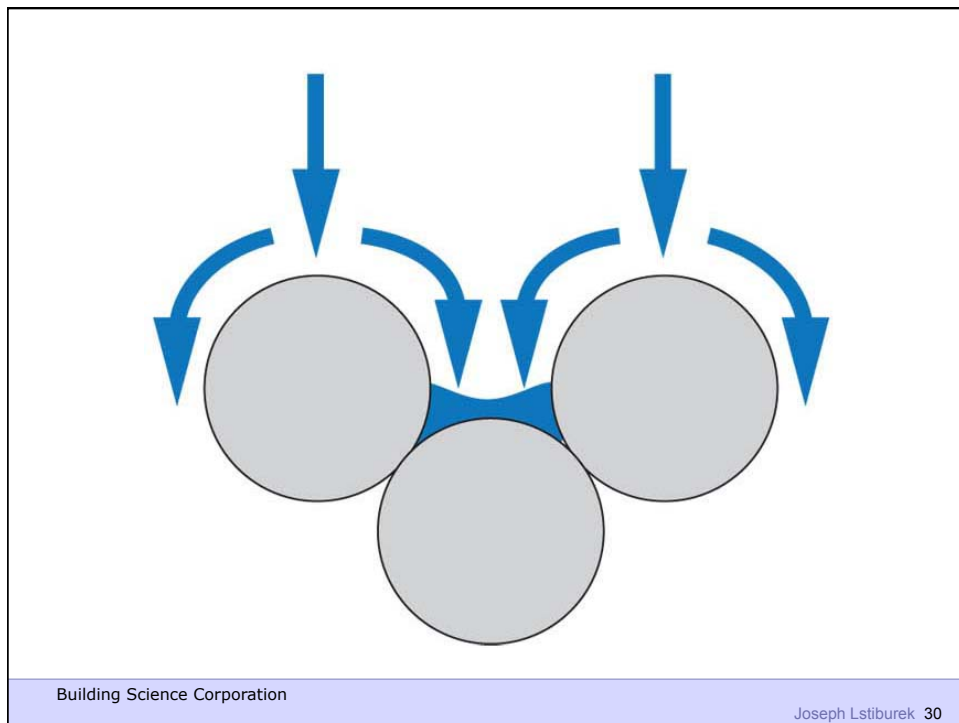
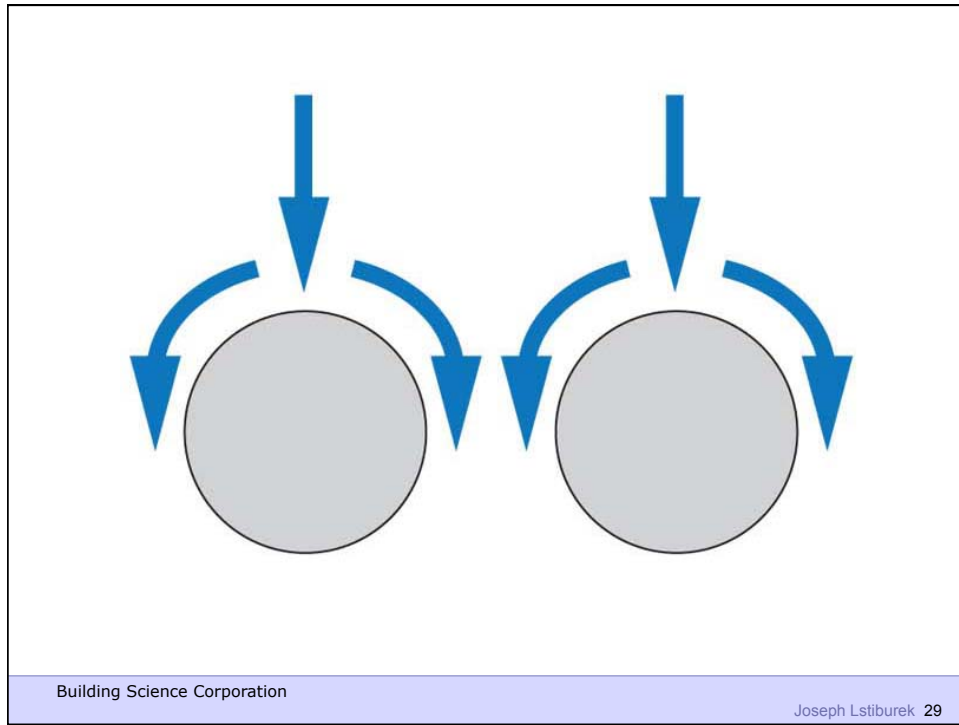



Building Science Corporation

Joseph Lstiburek 31

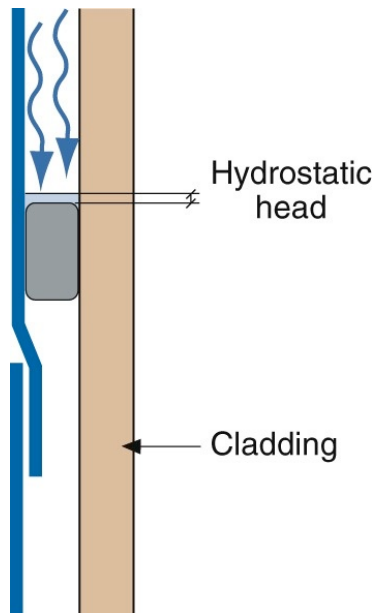

Building Science Corporation

Joseph Lstiburek 32



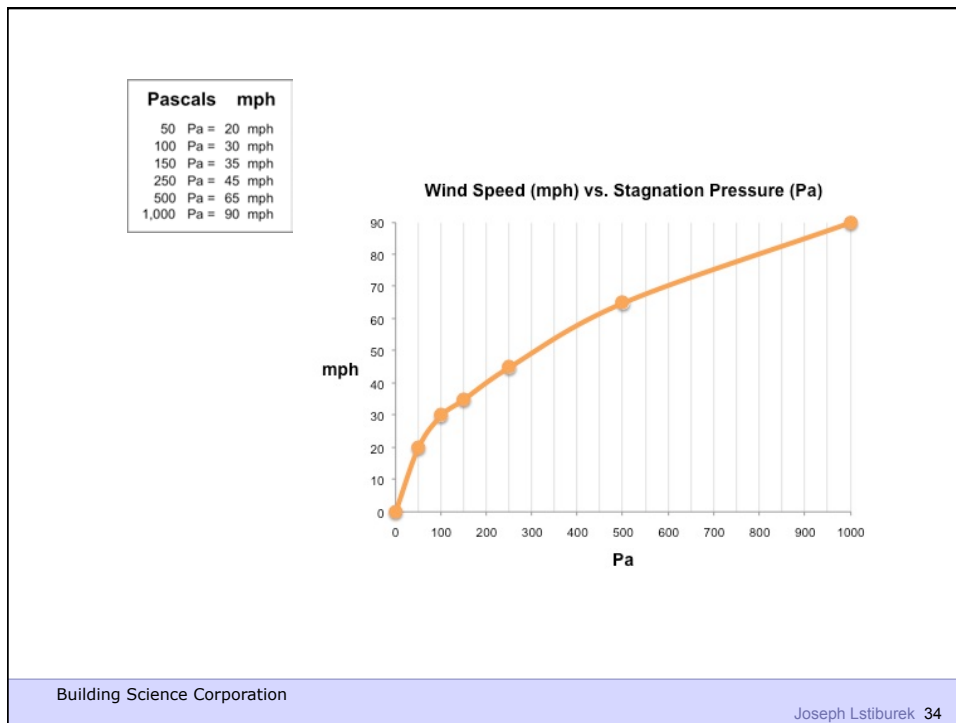
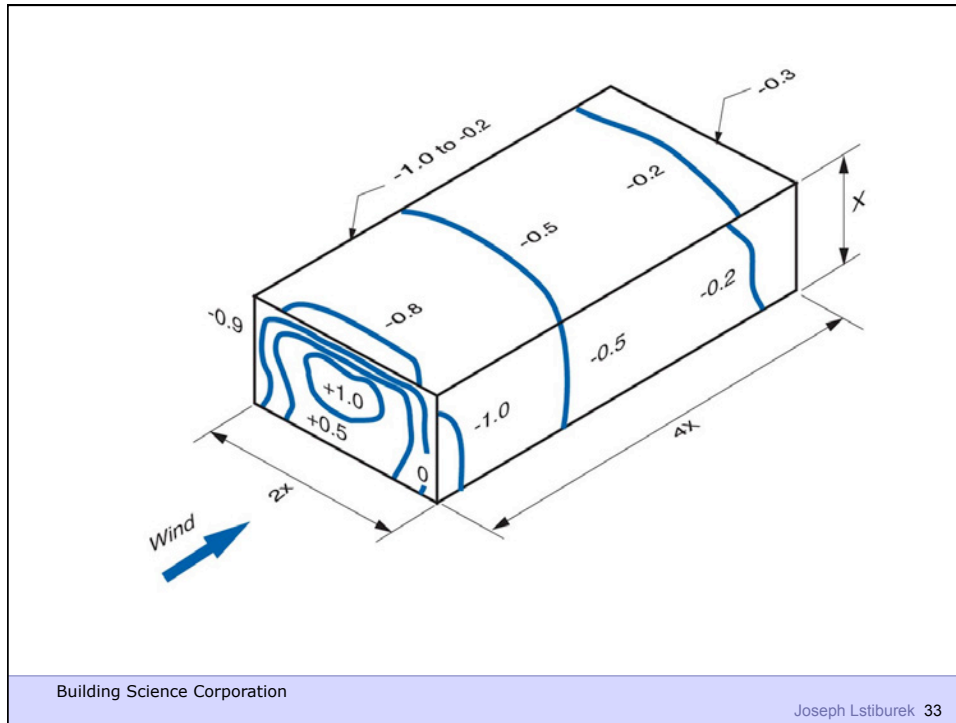



Building Science Corporation



Building Science Corporation

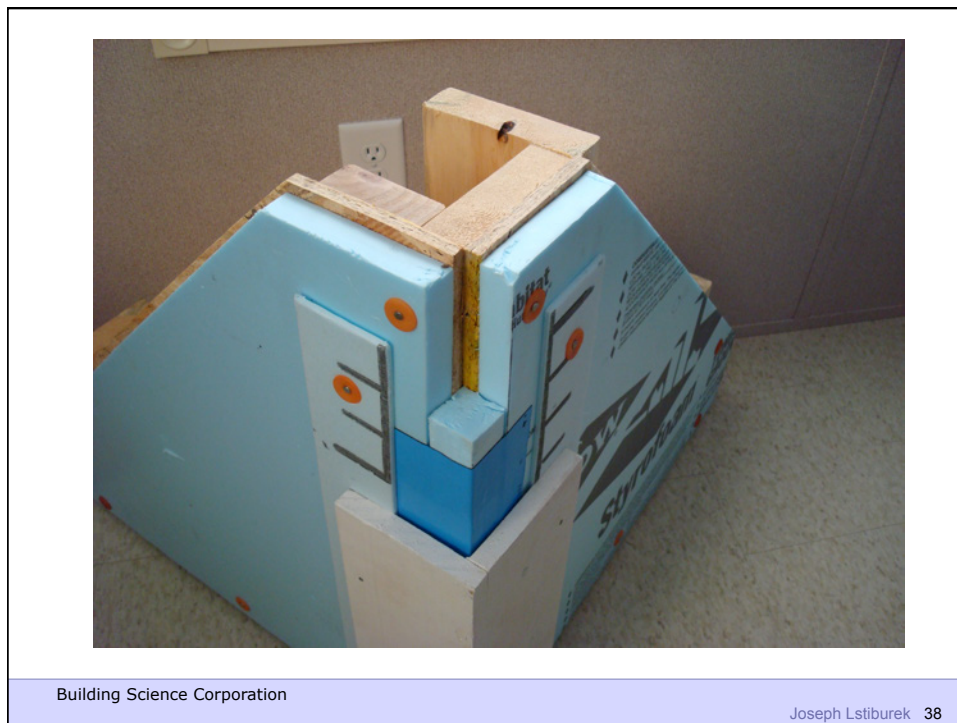
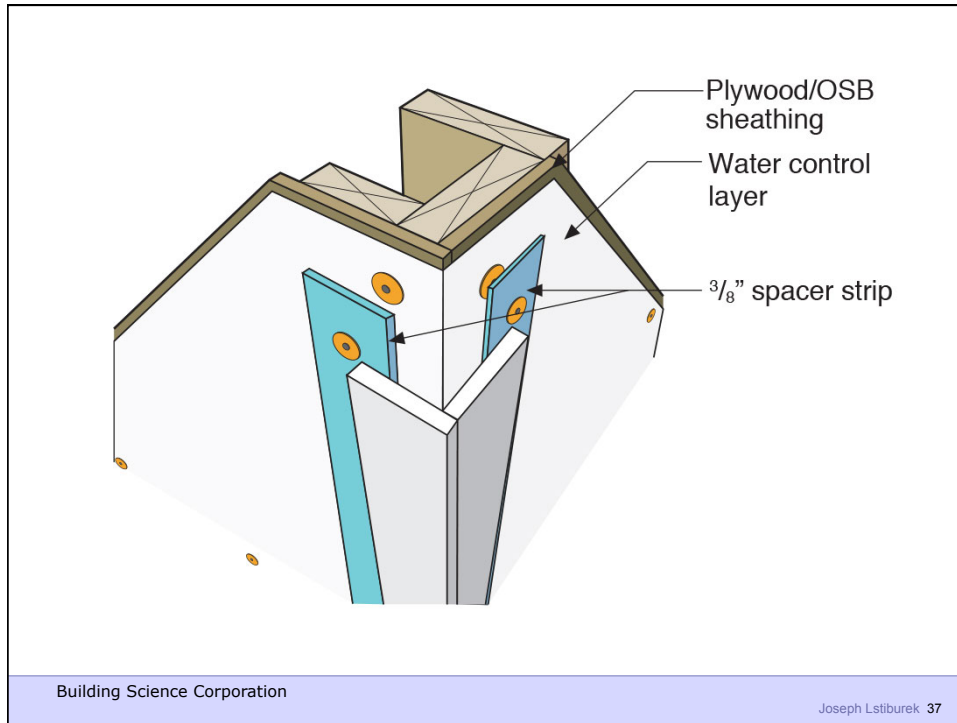



Building Science Corporation

Joseph Lstiburek 39

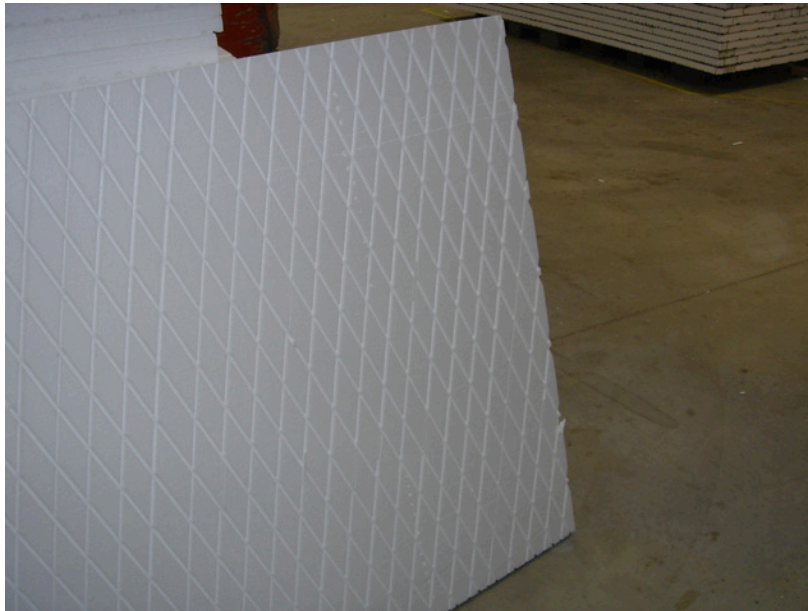

Building Science Corporation

Joseph Lstiburek 40

# Rain Screen

Building Science Corporation

Joseph Lstiburek 41

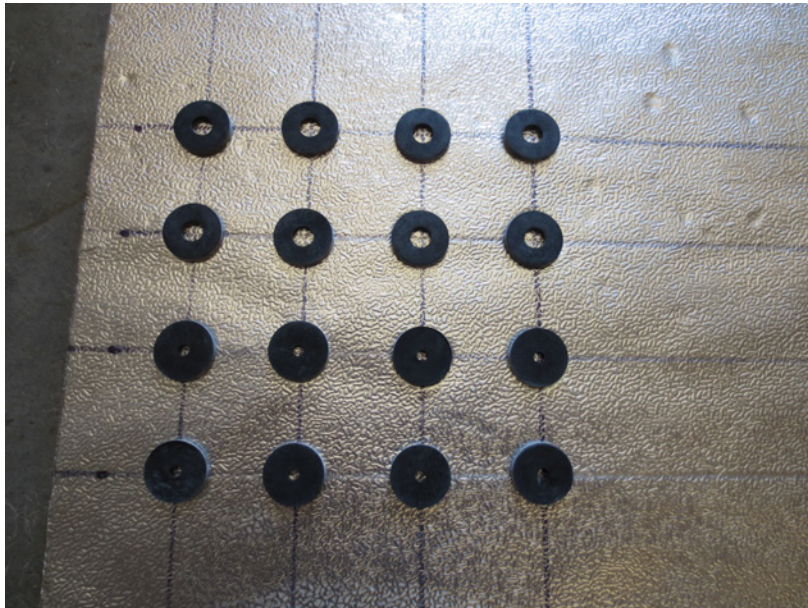

Building Science Corporation

Joseph Lstiburek 42

# Beer Screen?

Building Science Corporation

Joseph Lstiburek 43

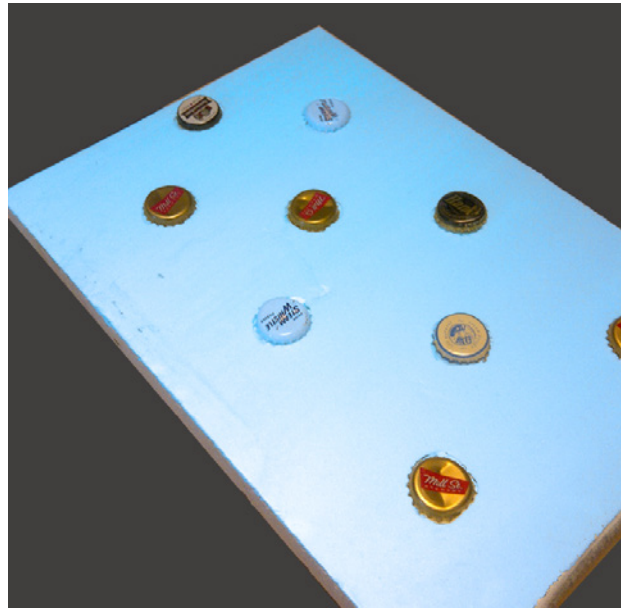

Building Science Corporation

Joseph Lstiburek 44

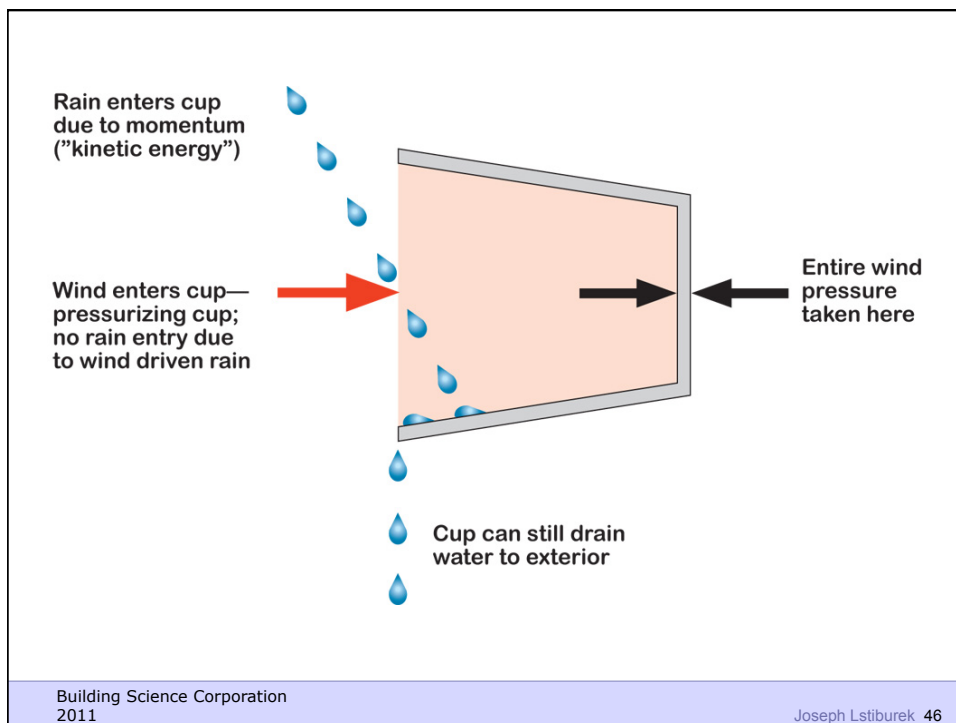
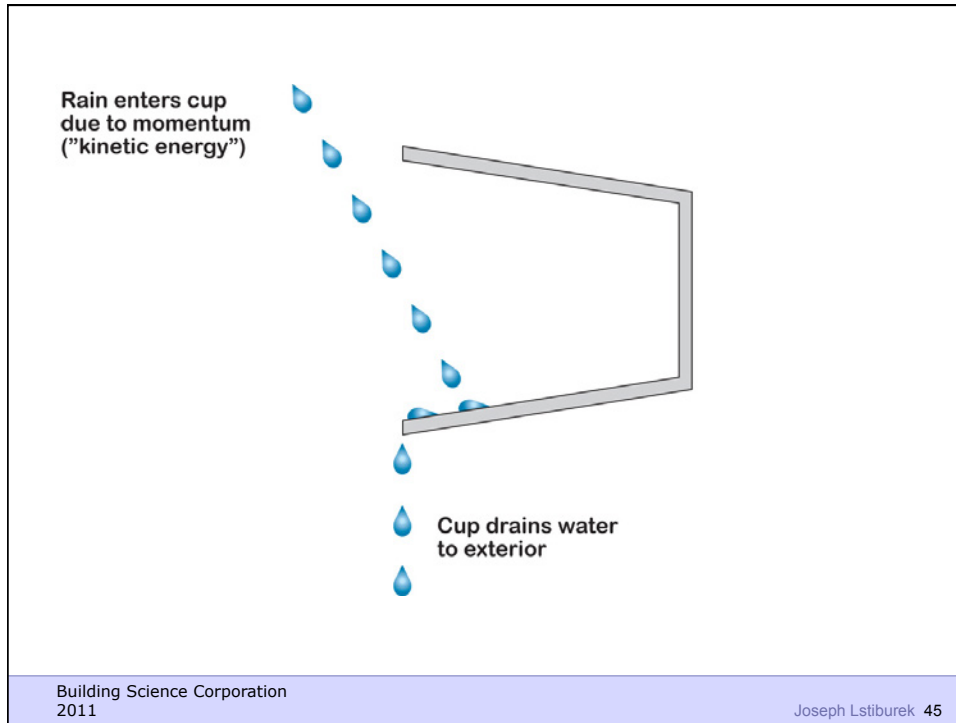

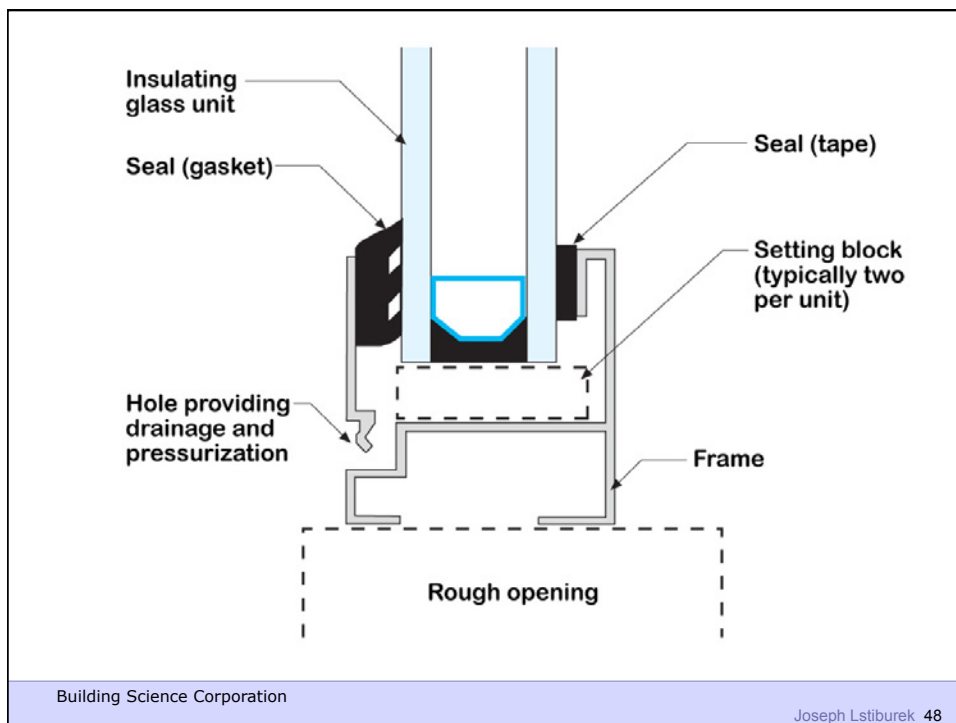
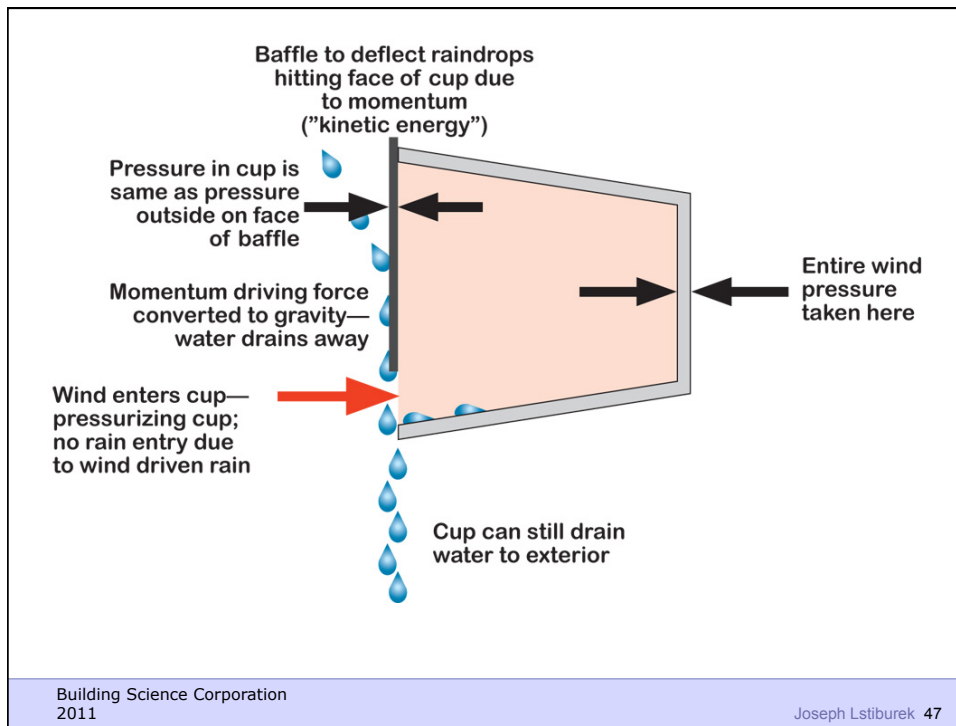



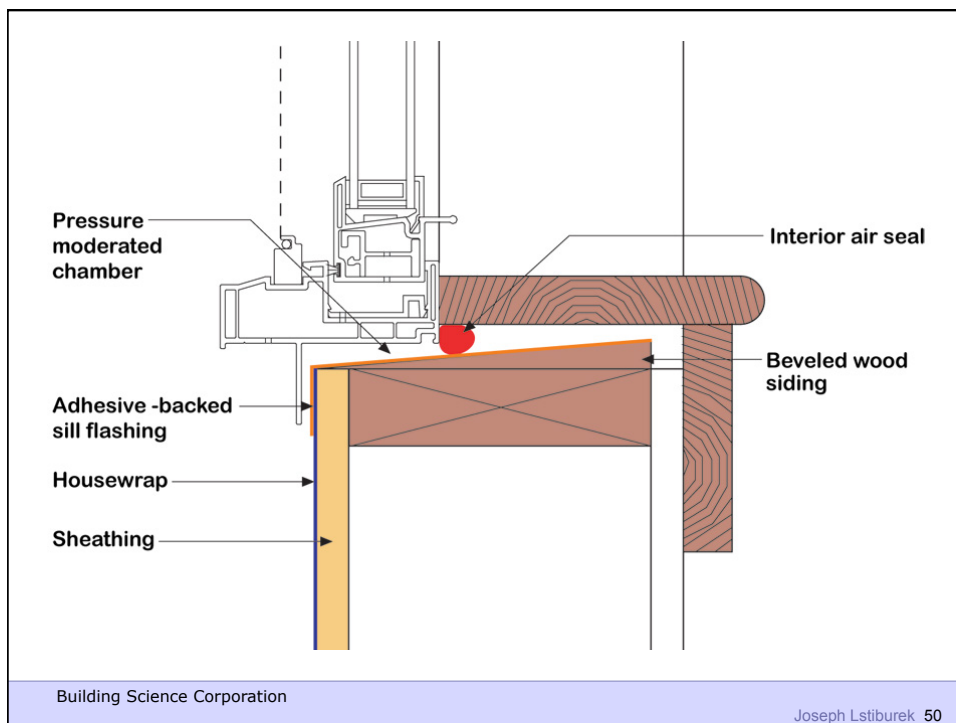
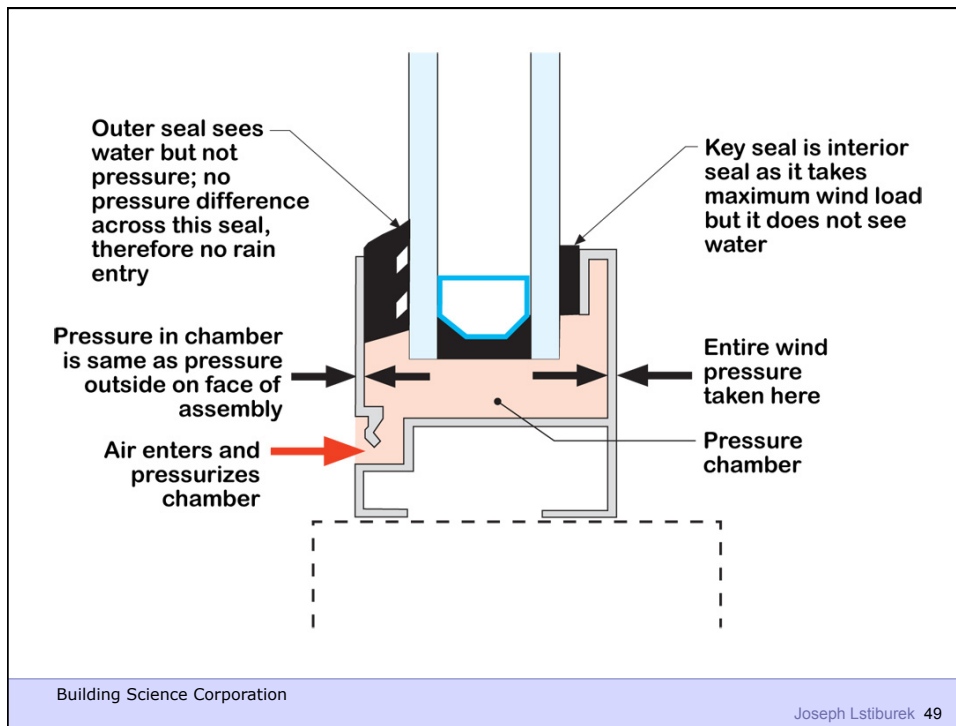



Building Science Corporation

Joseph Lstiburek 51



Building Science Corporation

Joseph Lstiburek 52

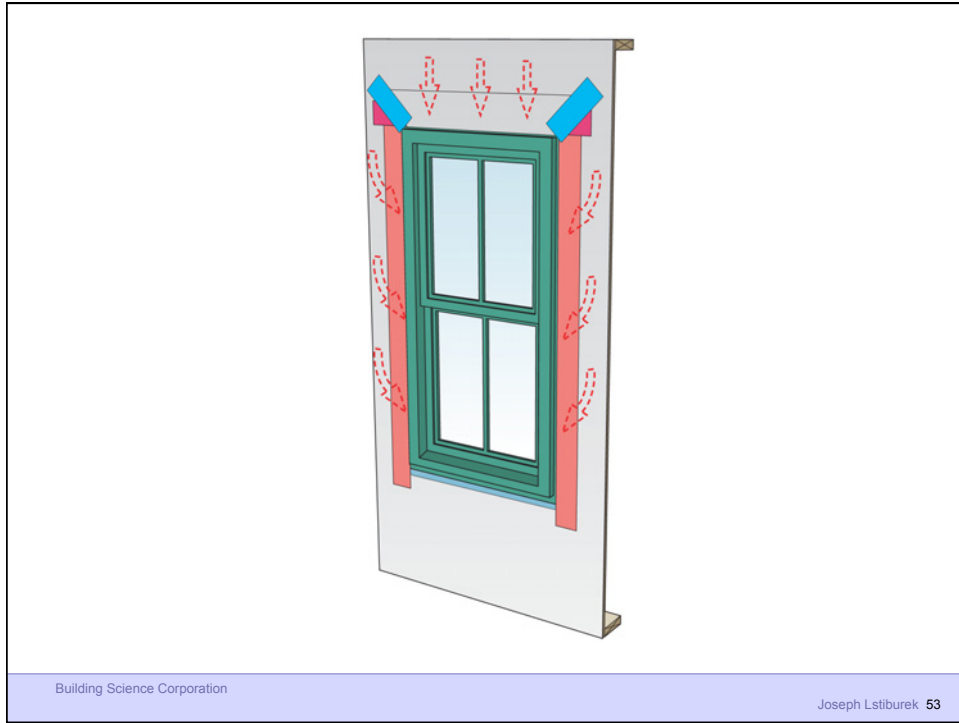

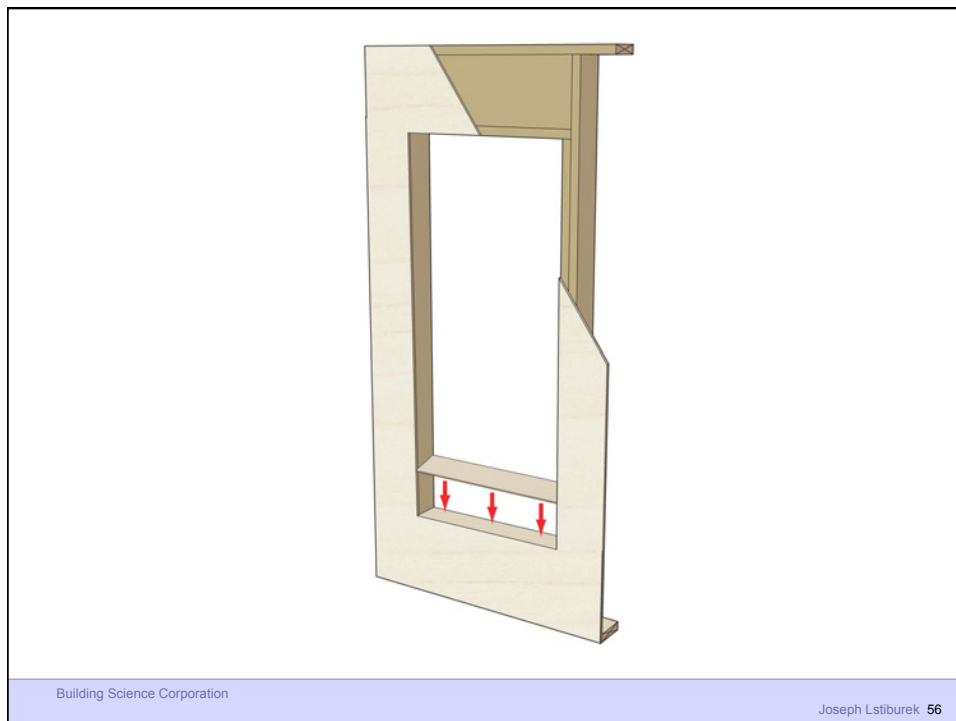
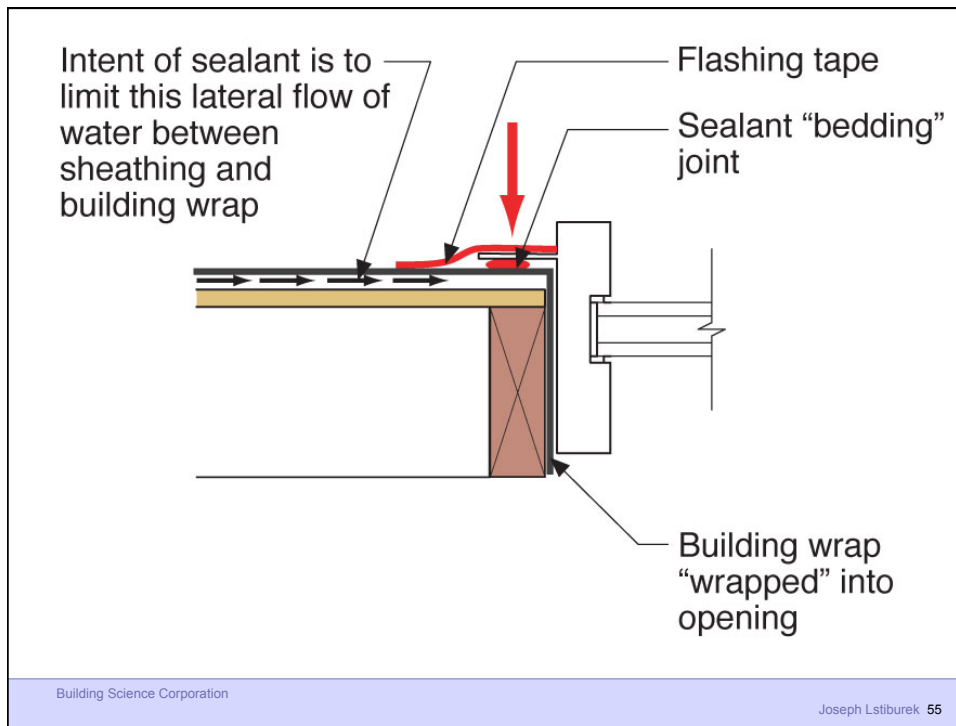

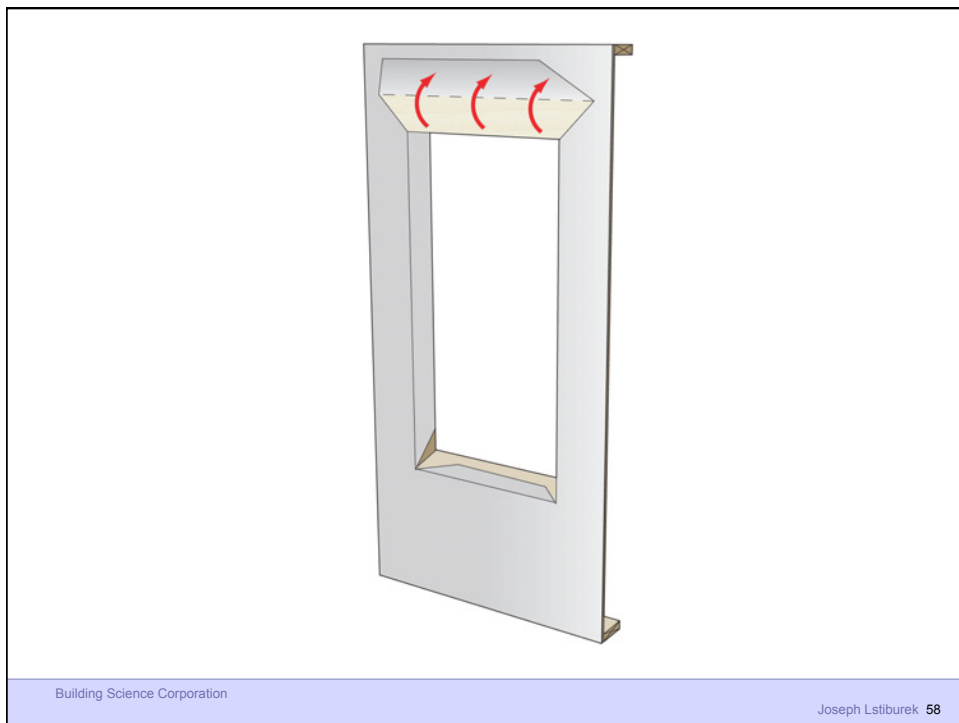
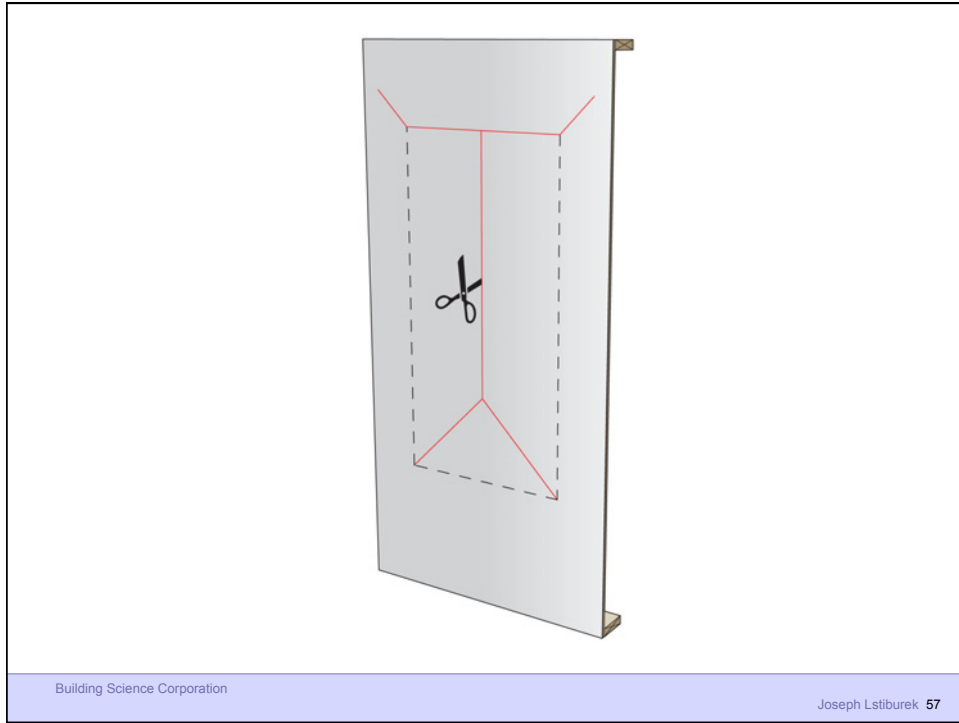

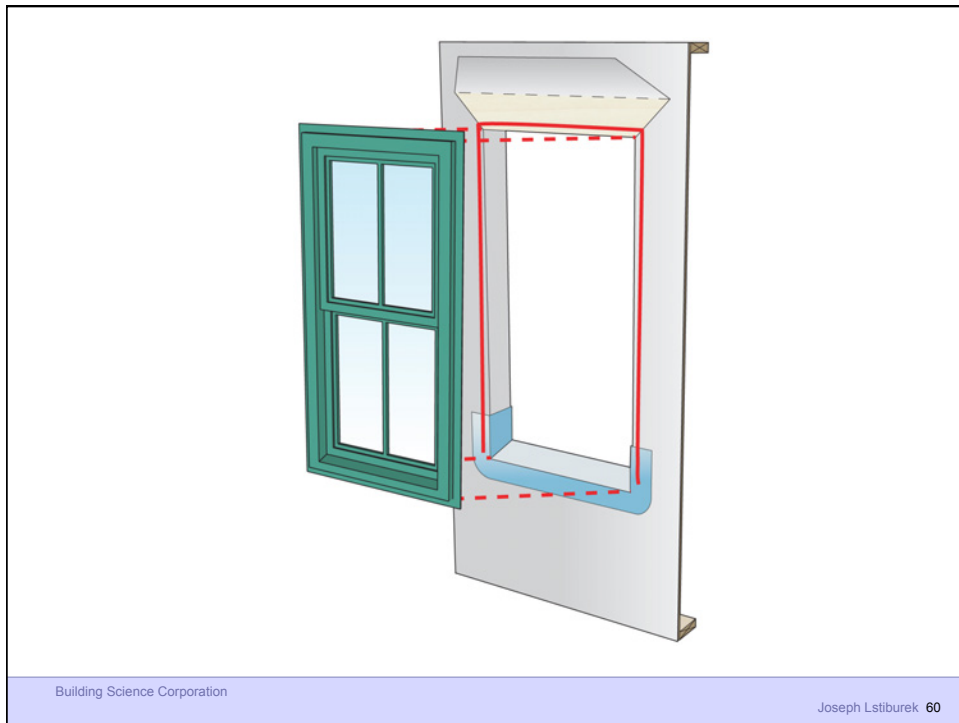
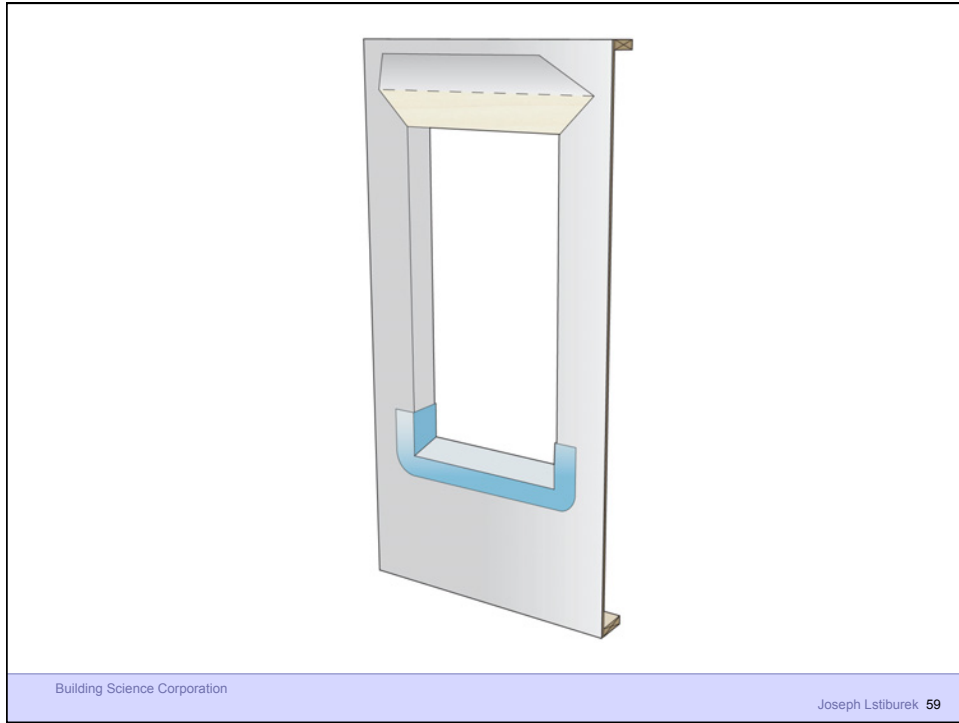

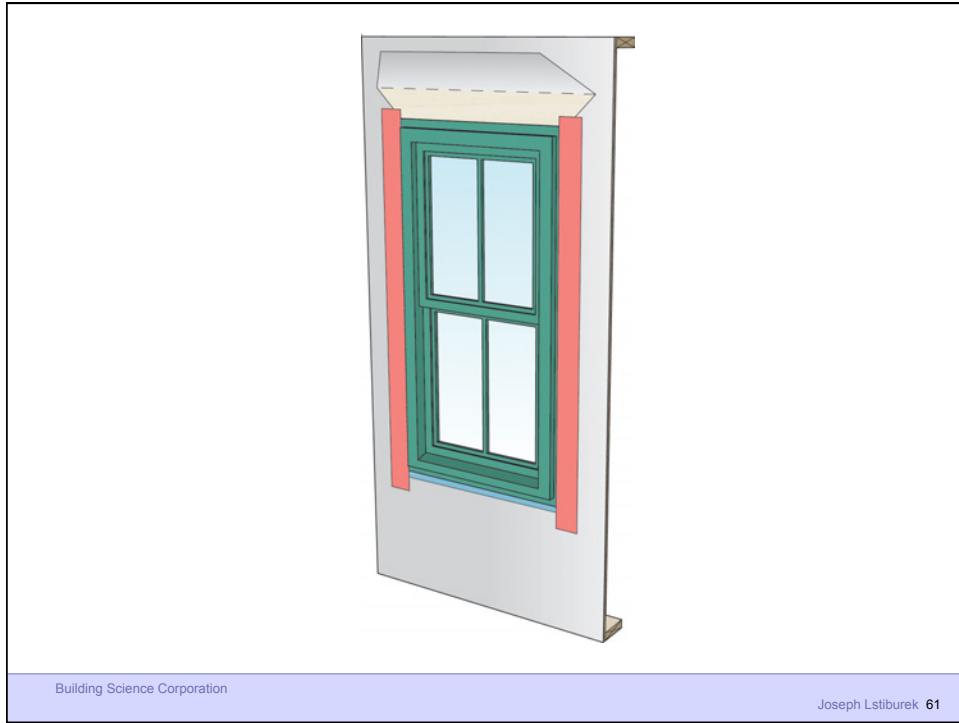

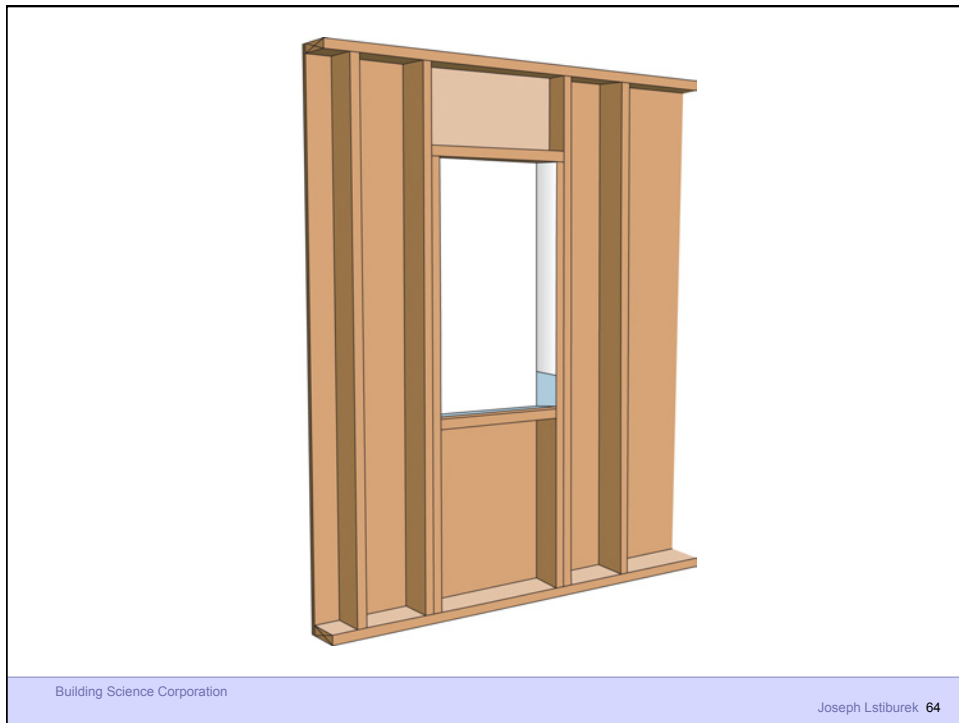
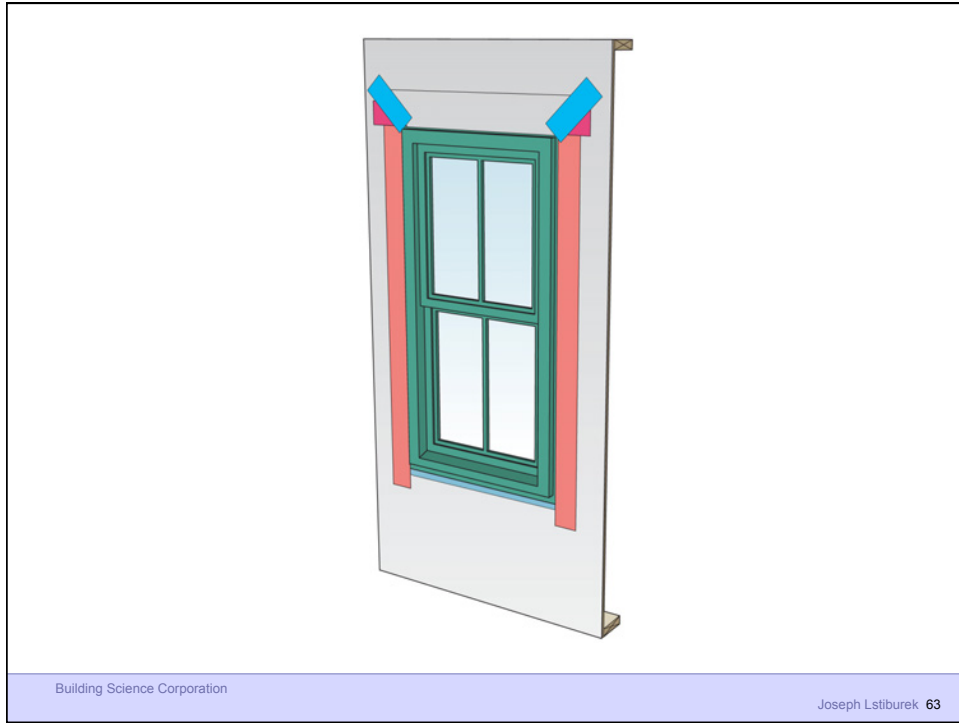



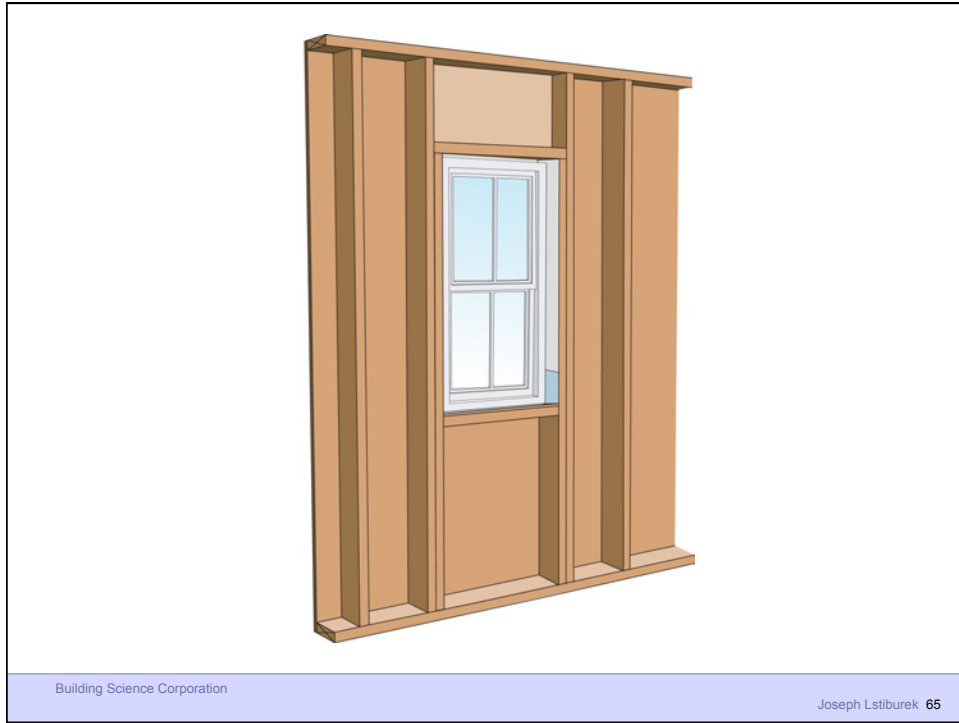



Building Science Corporation

Joseph Lstiburek 67



Building Science Corporation

Joseph Lstiburek 68



Building Science Corporation

Joseph Lstiburek 69



Building Science Corporation

Joseph Lstiburek 70

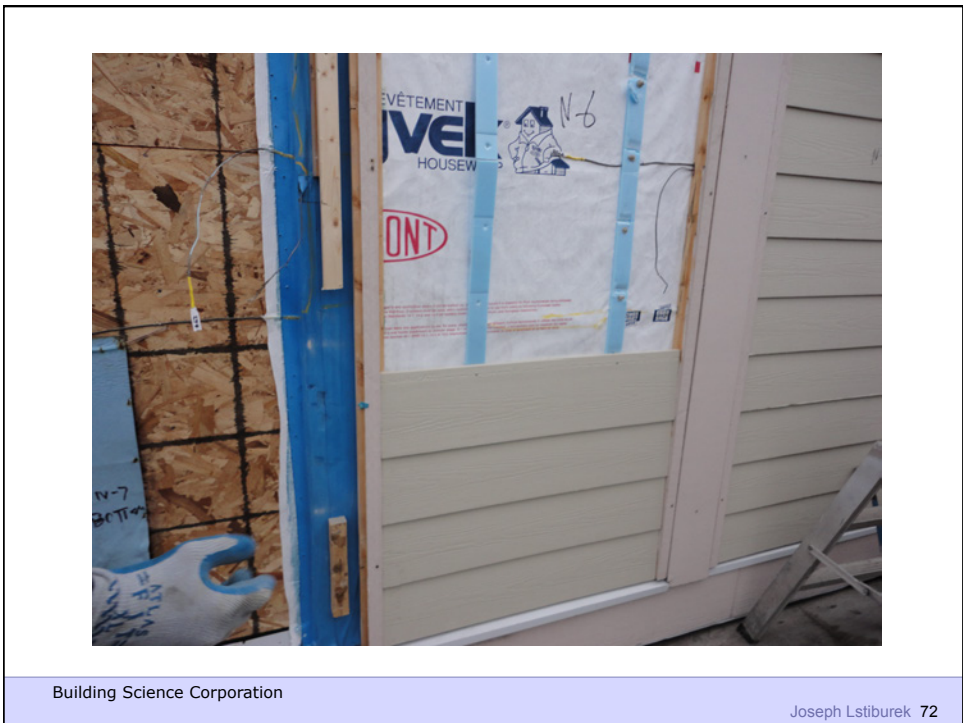



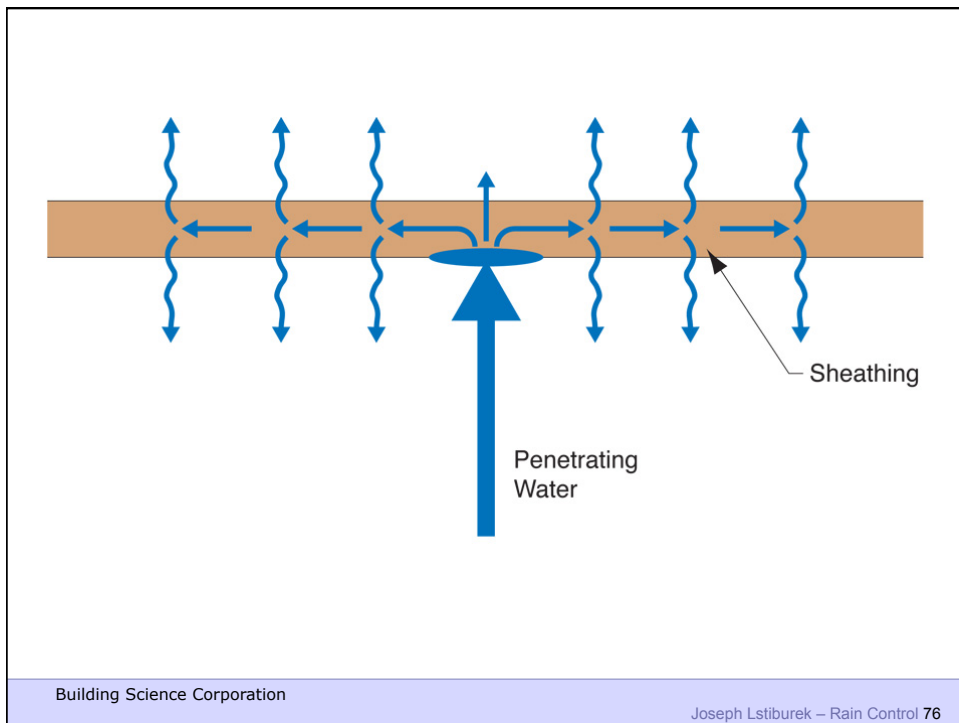

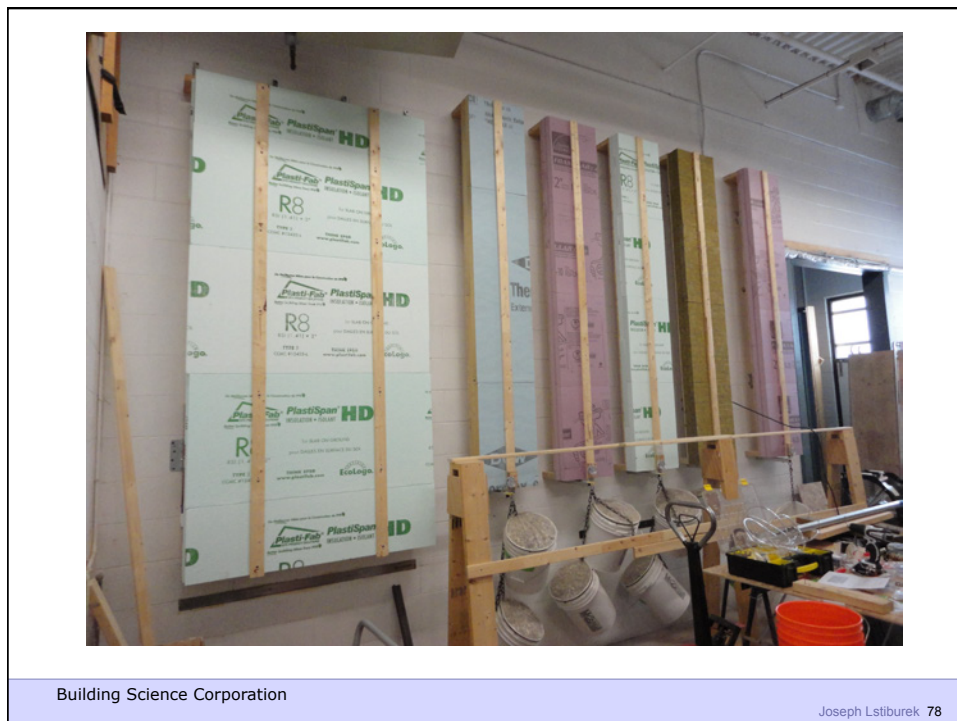
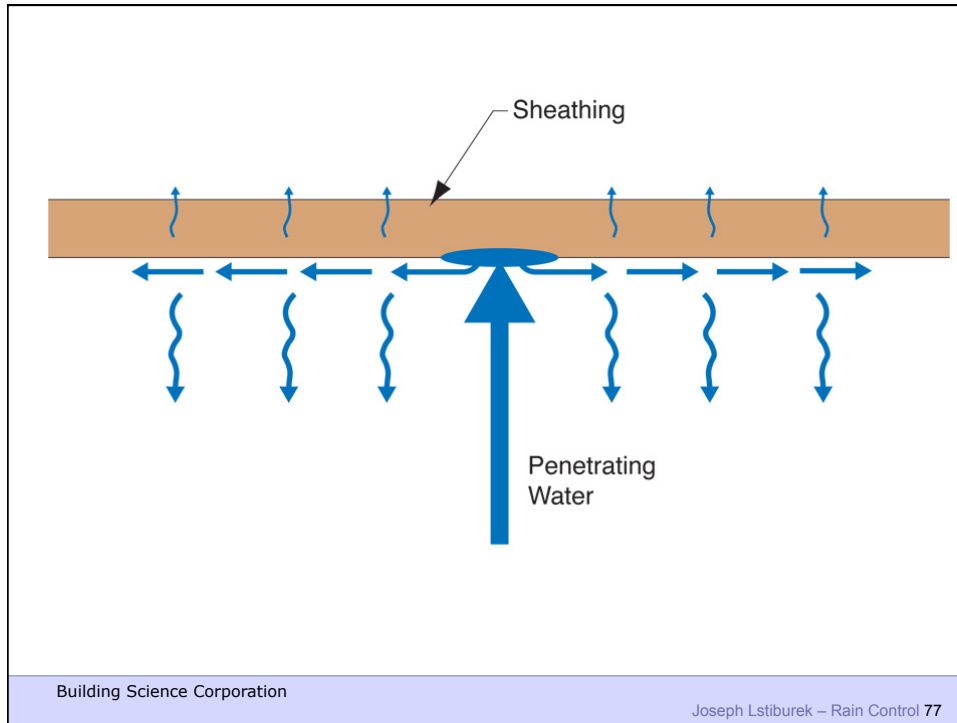







# Rockwool

1x3 furring @ 24" o.c.  
 #10 screws @ 16" o.c. vertically  
 Result: 20 psf cladding weight  
 with < 2/100" deflection

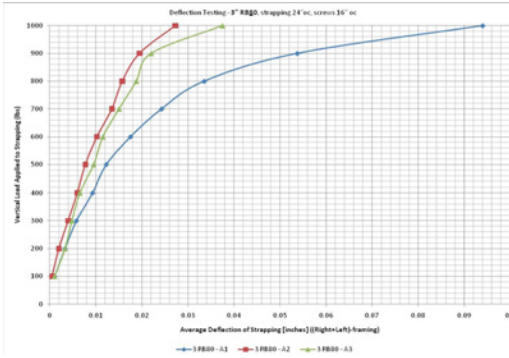

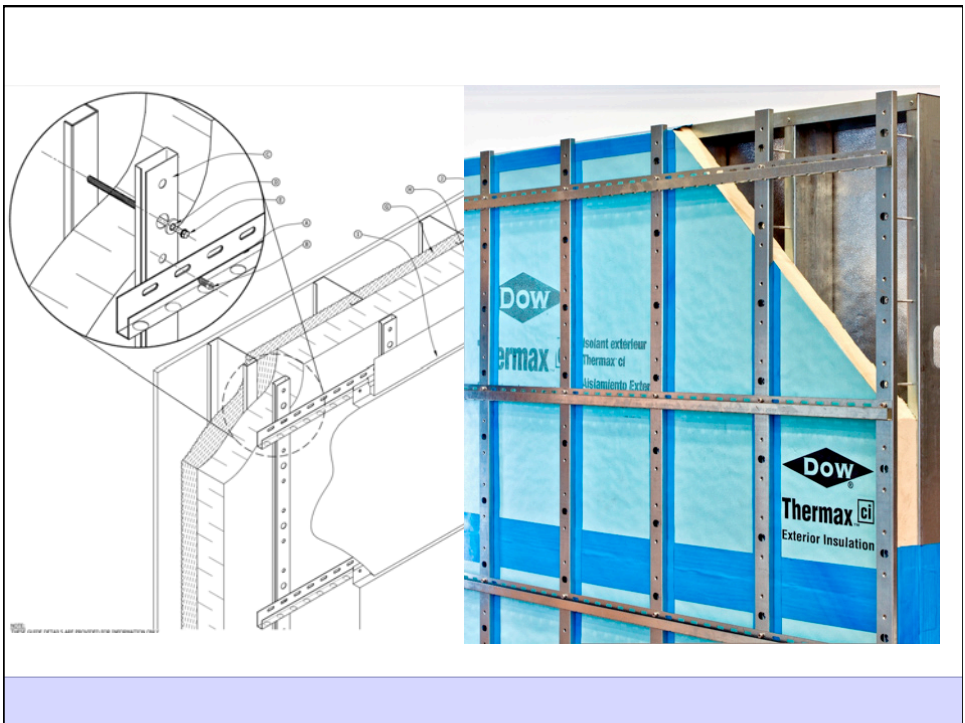
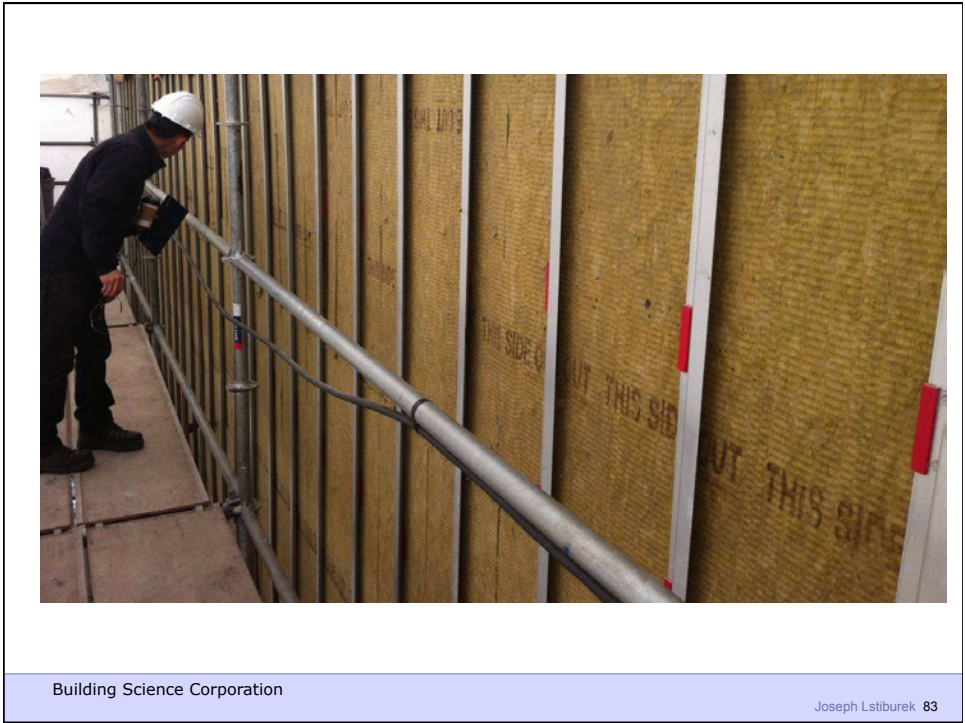

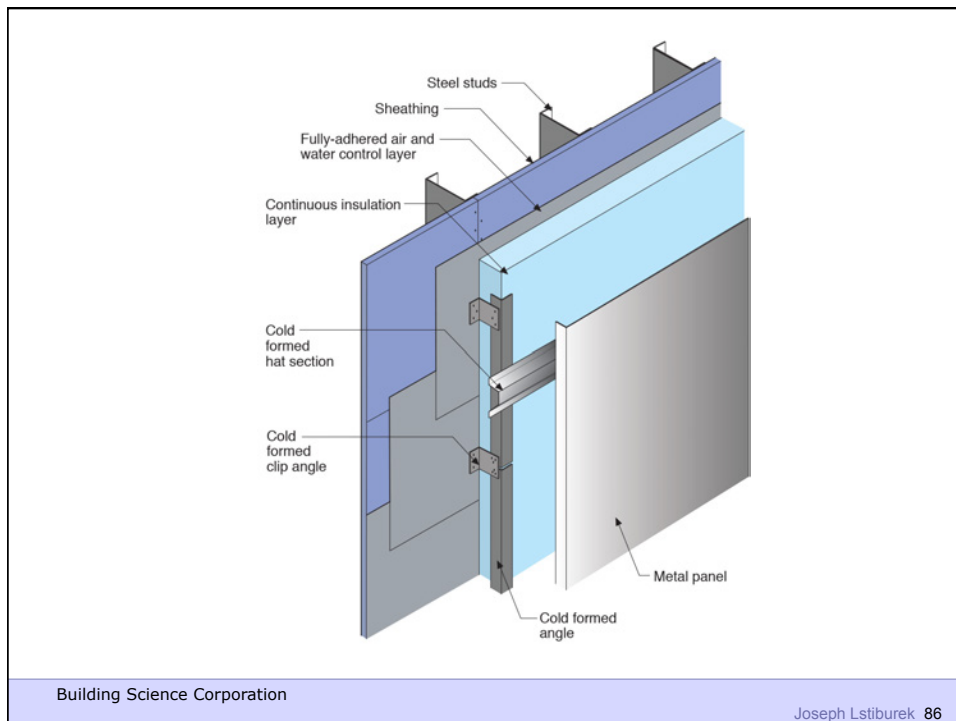
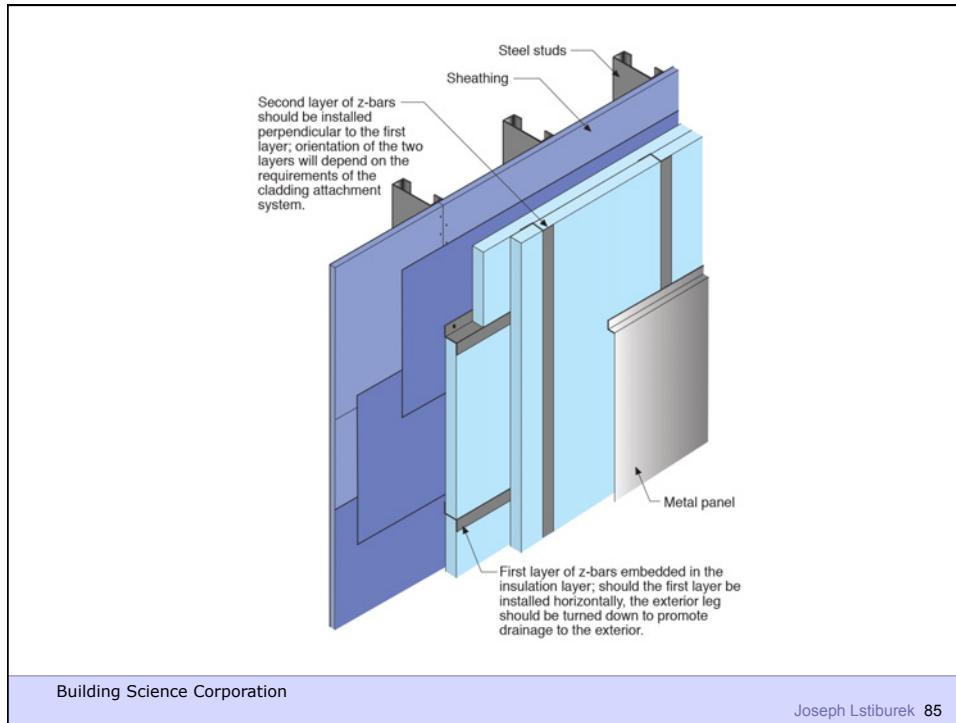

## Housewraps are so 80's

Building Science Corporation

Joseph Lstiburek 87



Building Science Corporation

Joseph Lstiburek 88



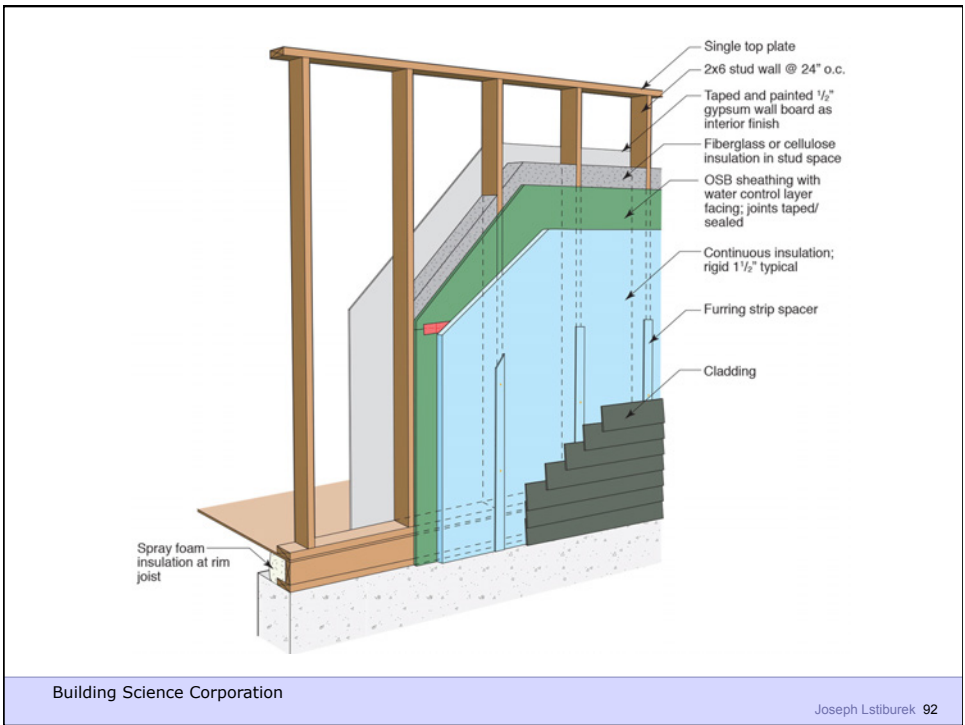

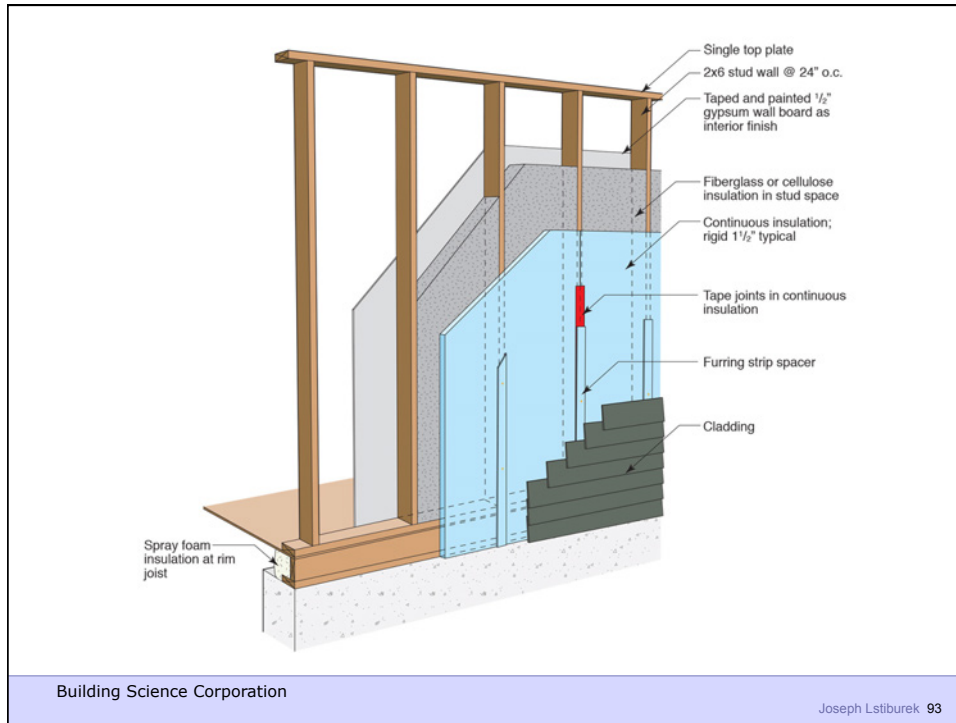

## Innies and Outies

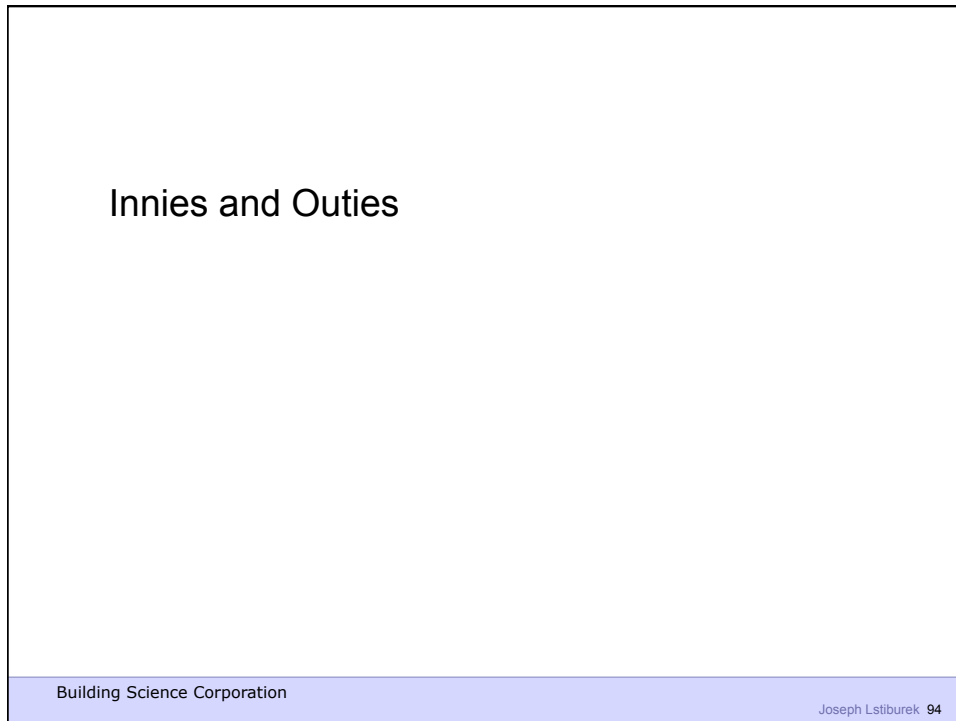

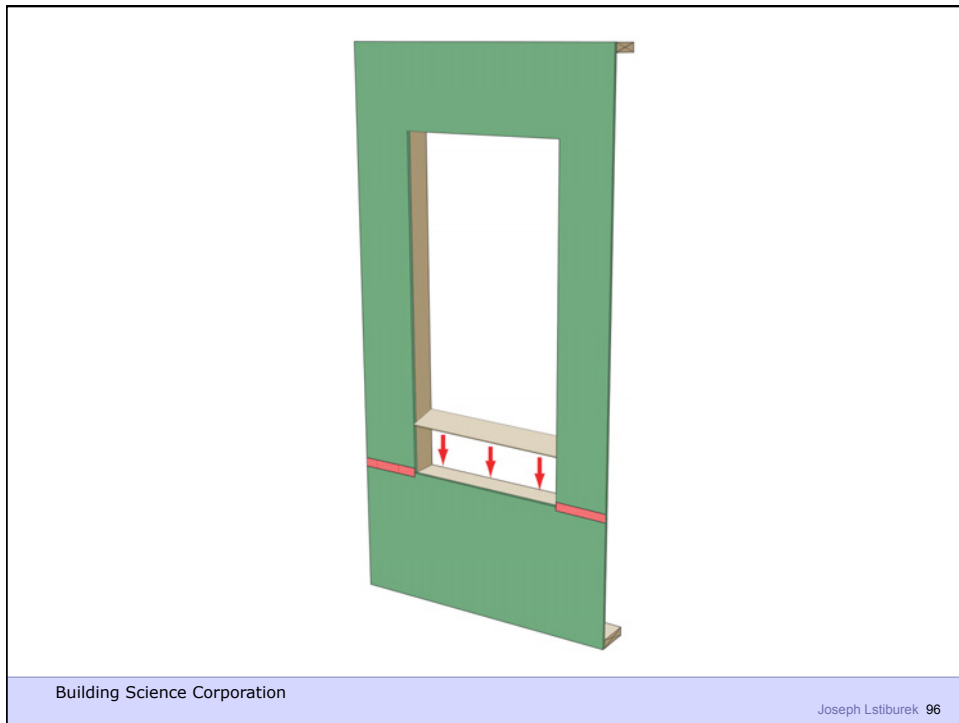
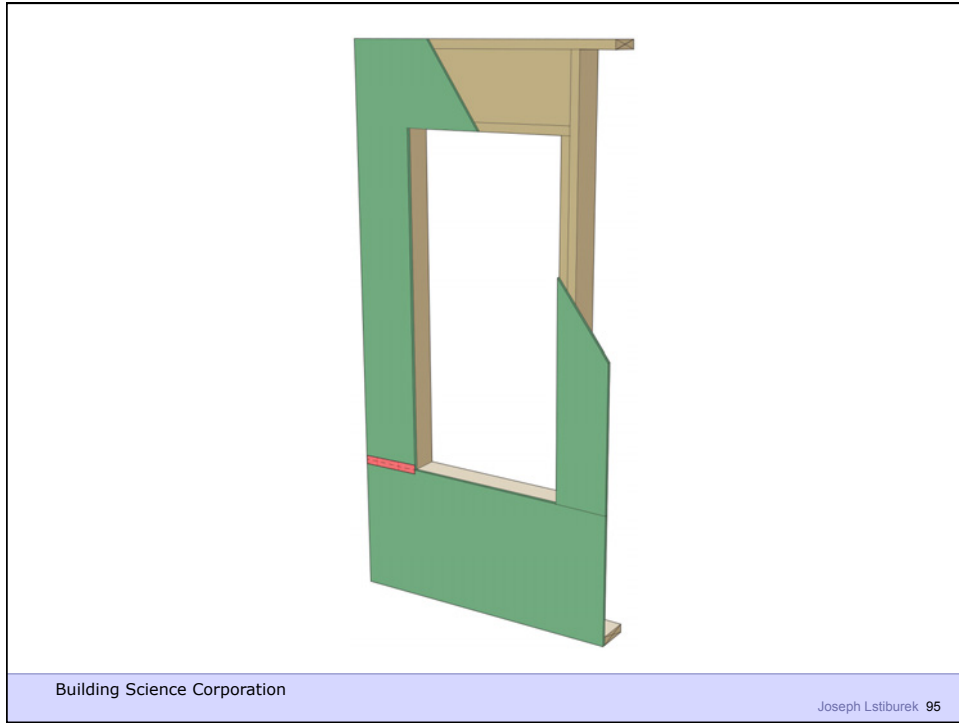



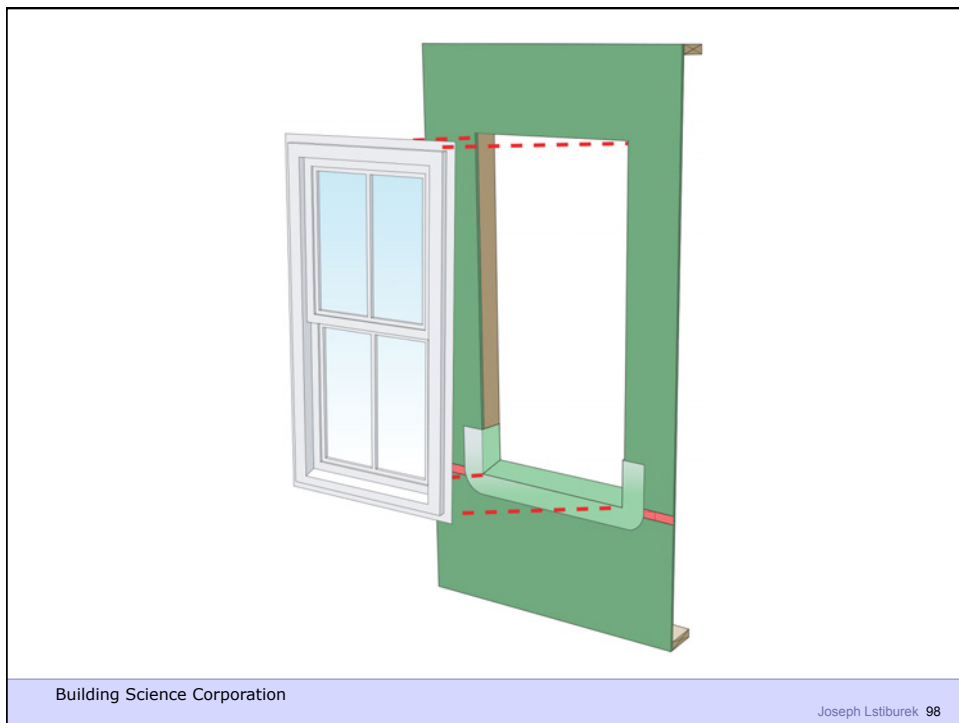
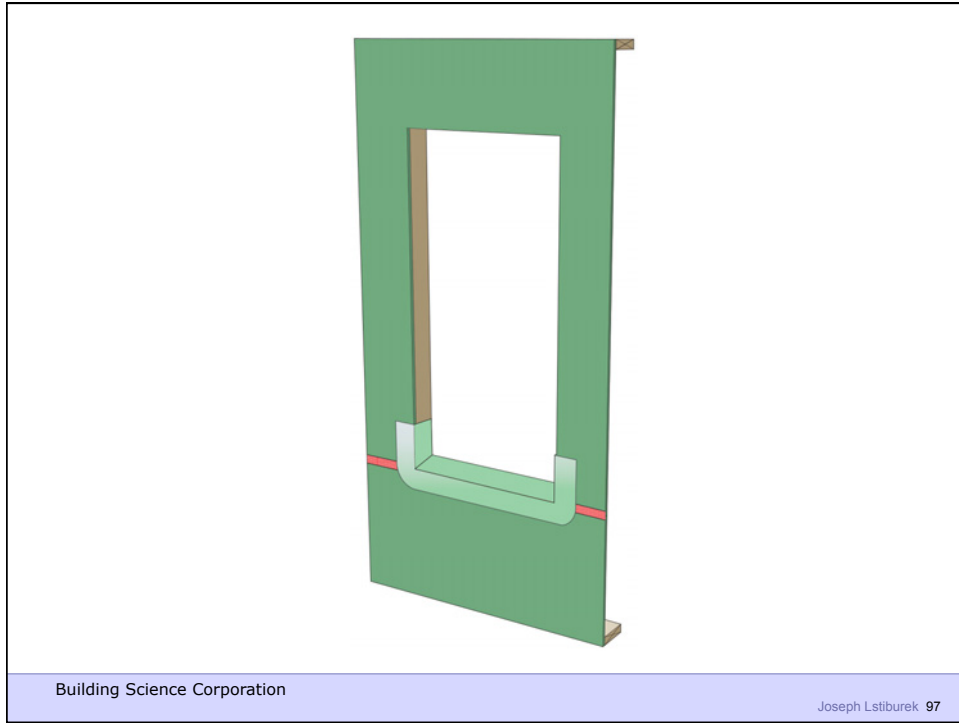

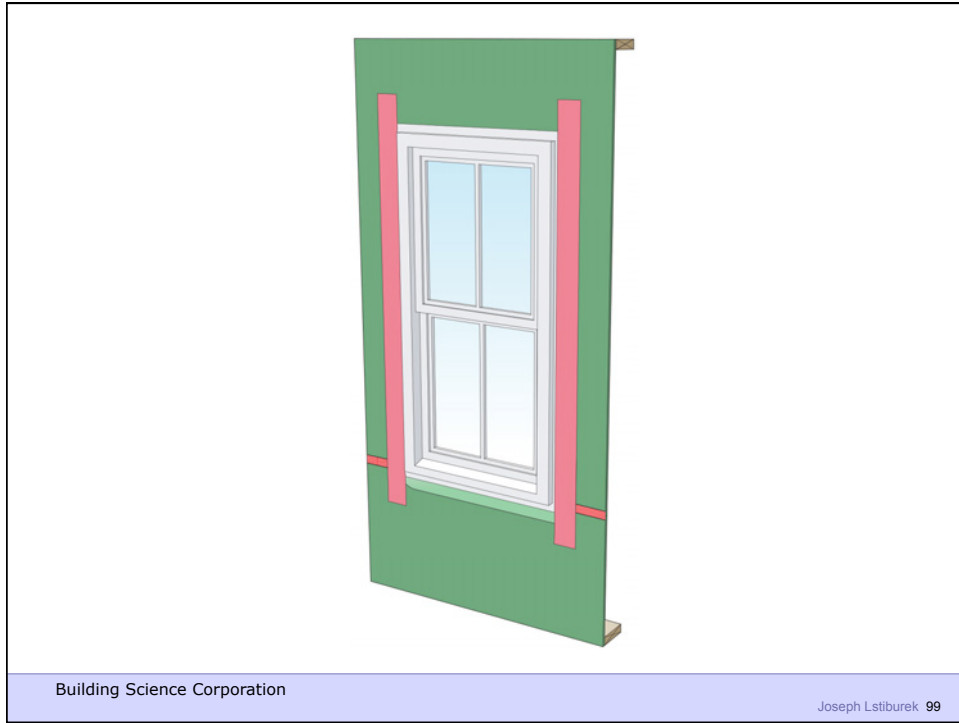

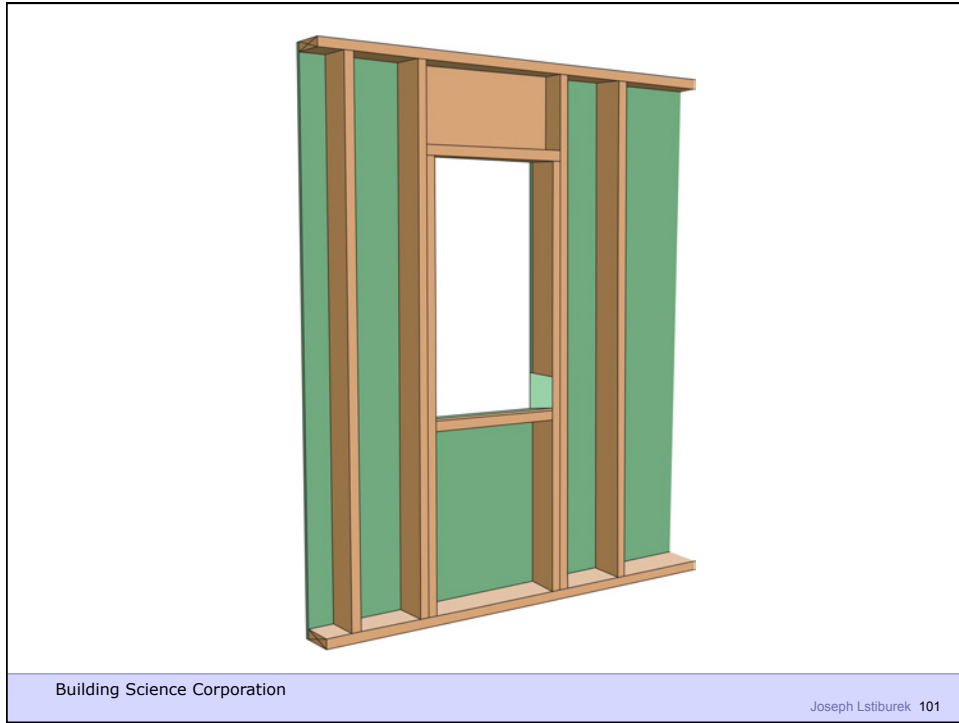

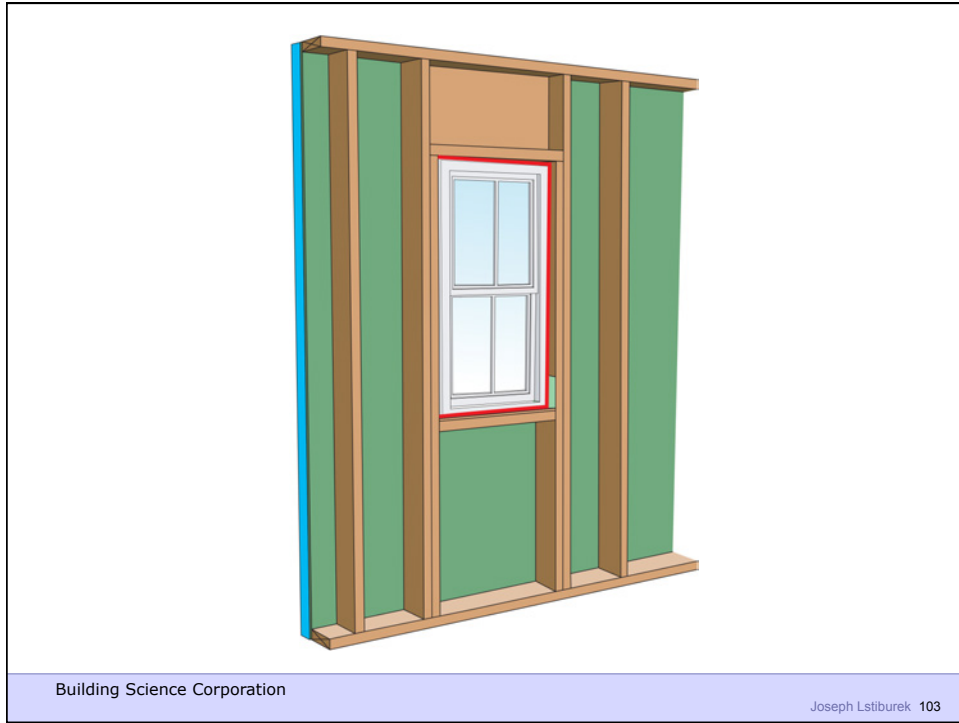

# Outies

Building Science Corporation

Joseph Lstiburek 105

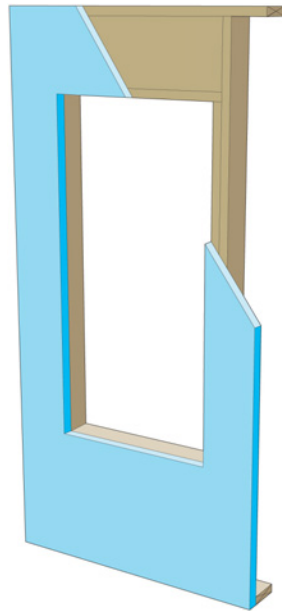

Building Science Corporation

Joseph Lstiburek 106

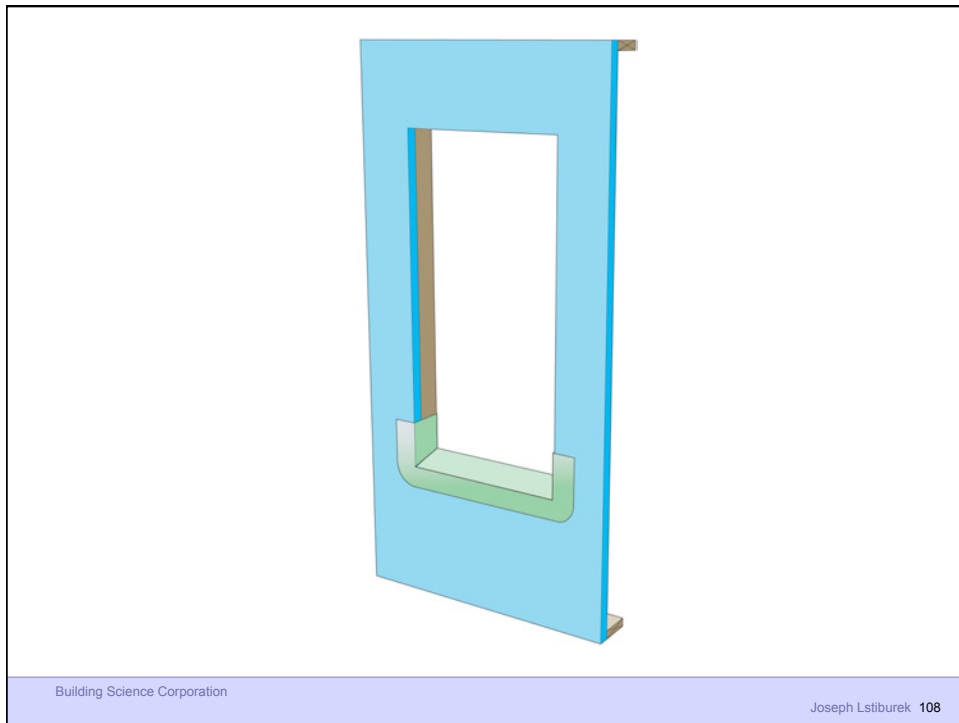
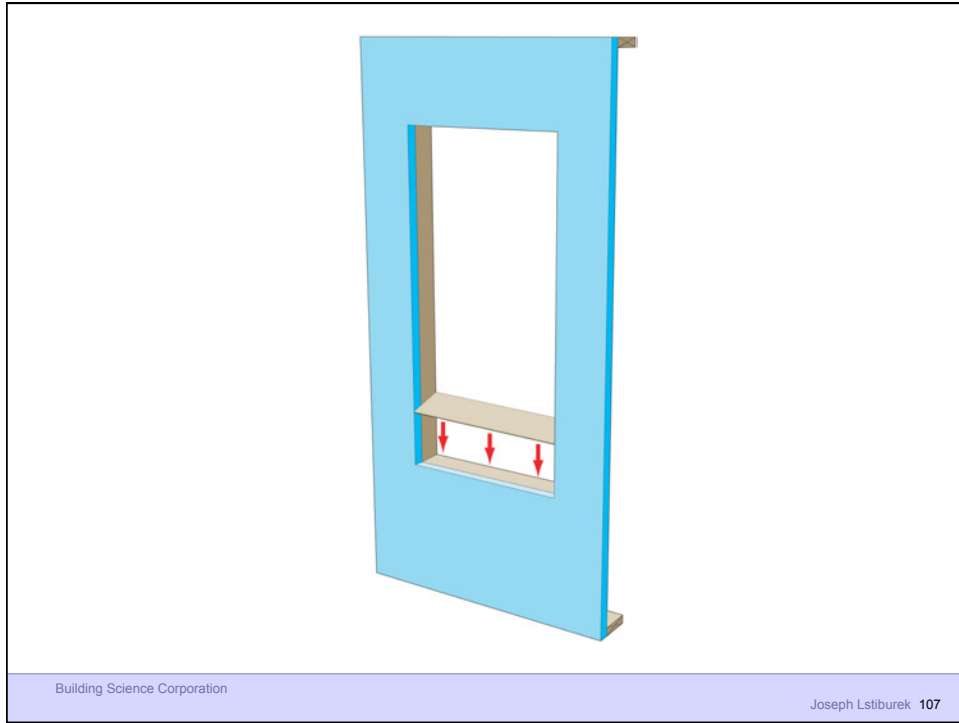

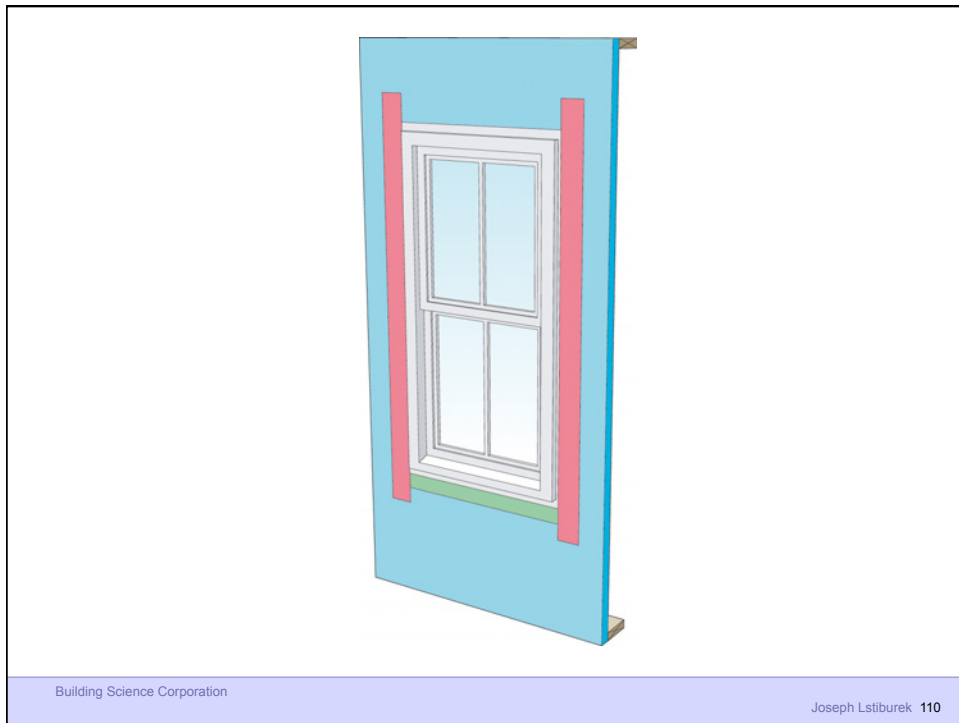
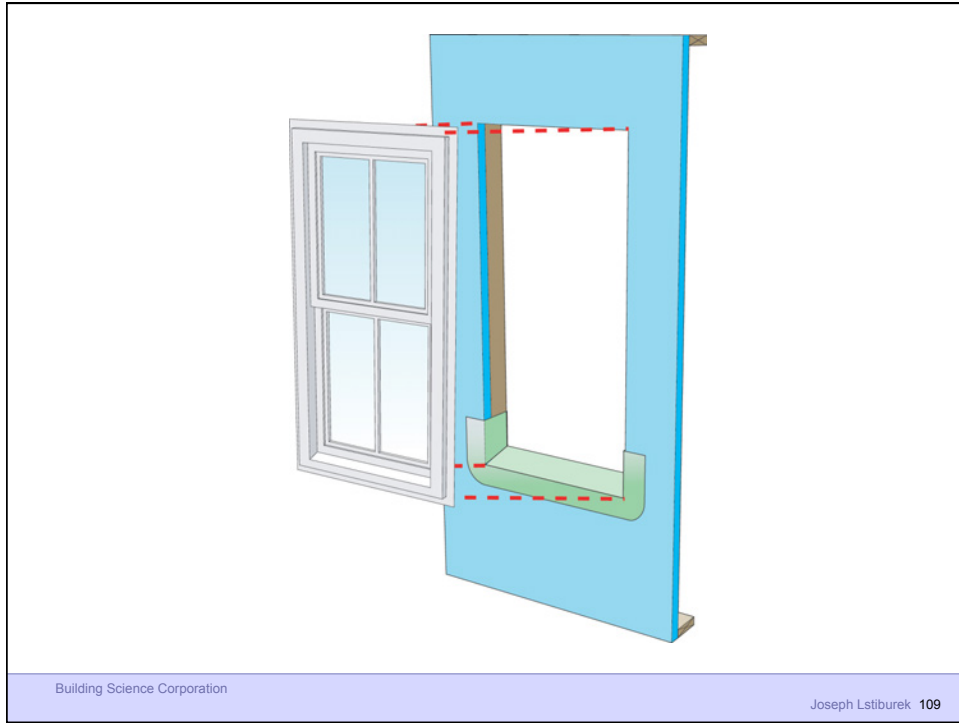

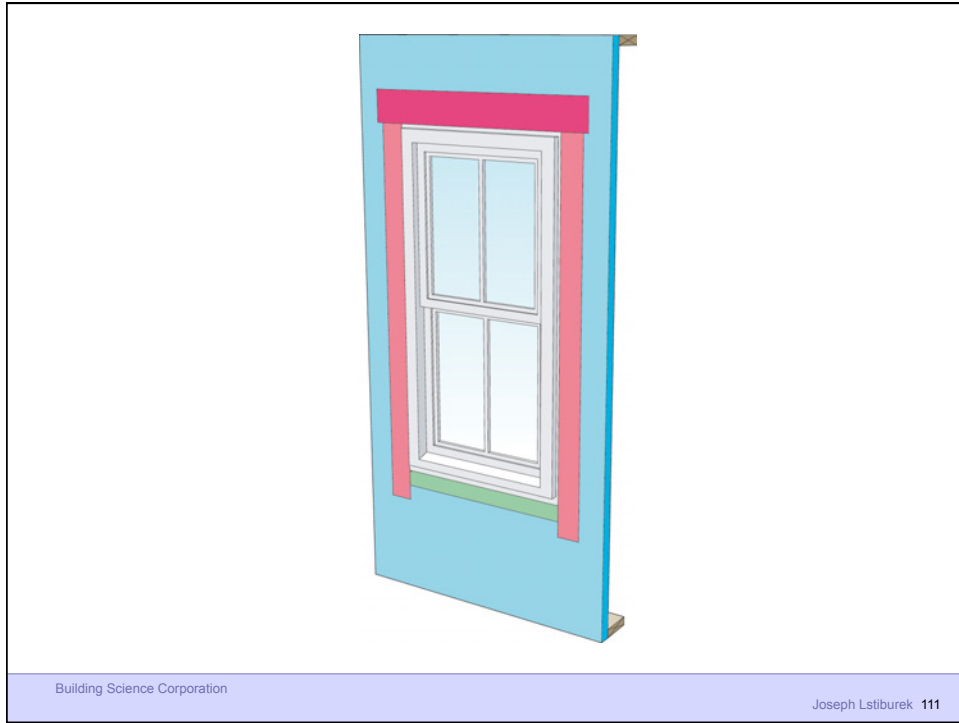



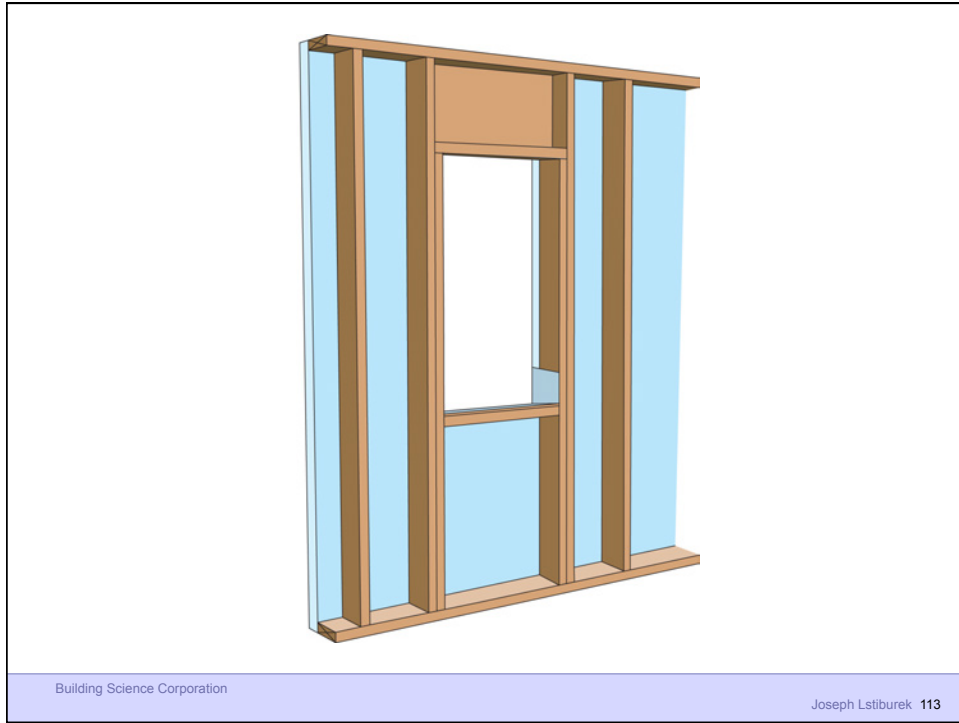



## Outies with Fluffy Rocks

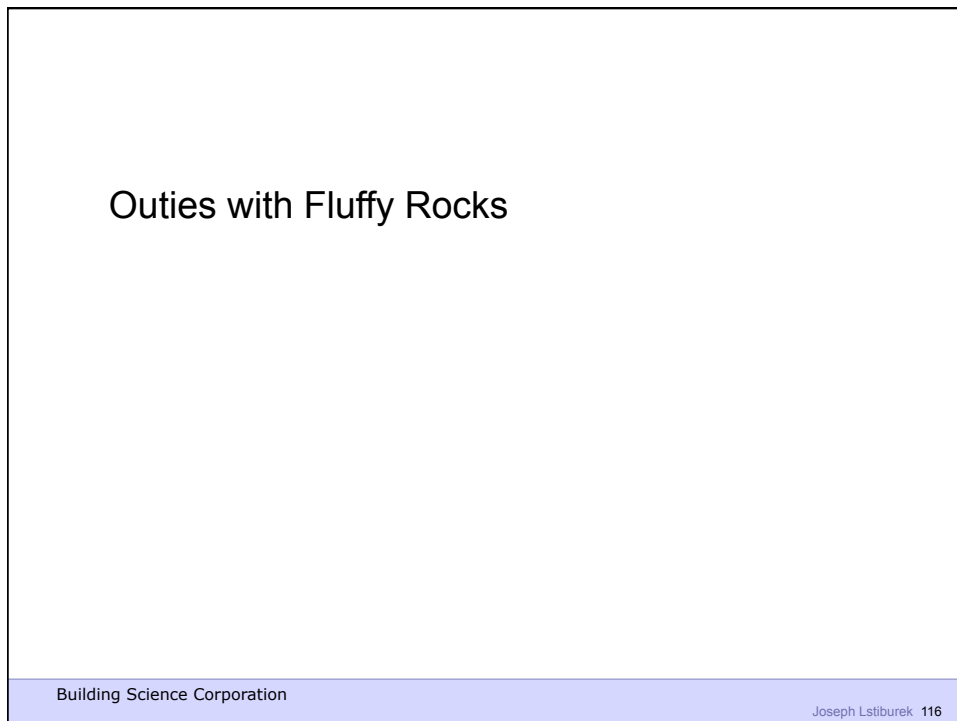

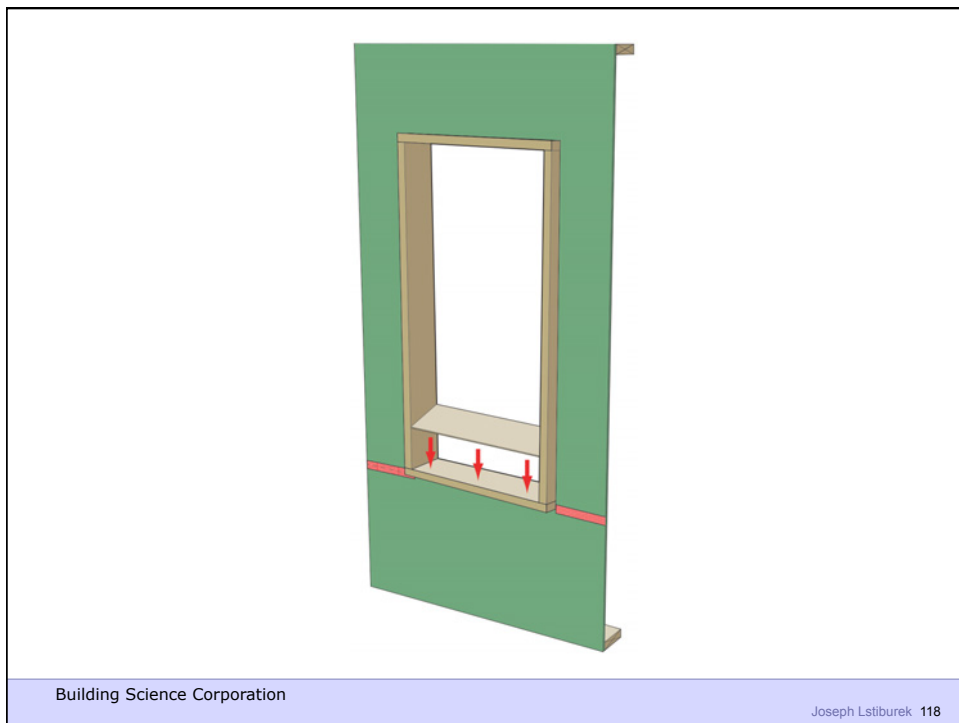
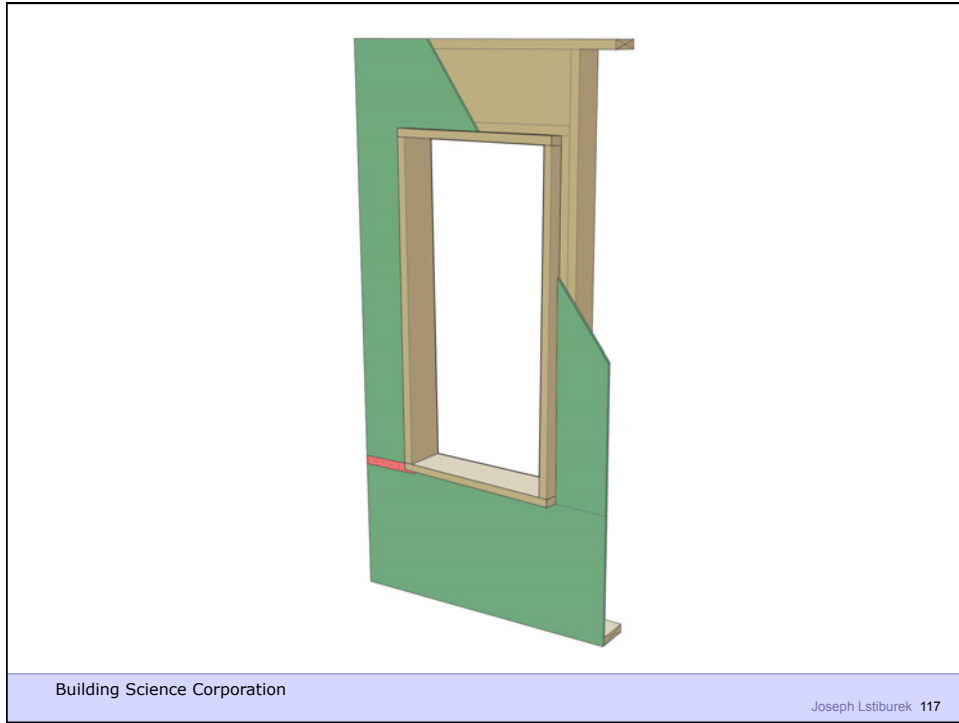

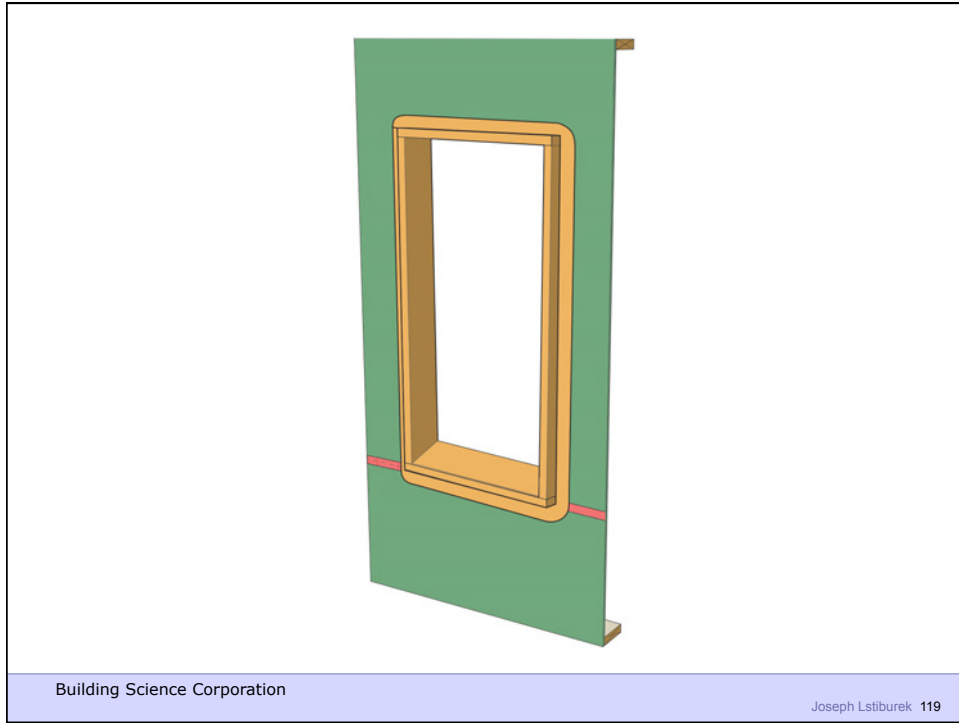

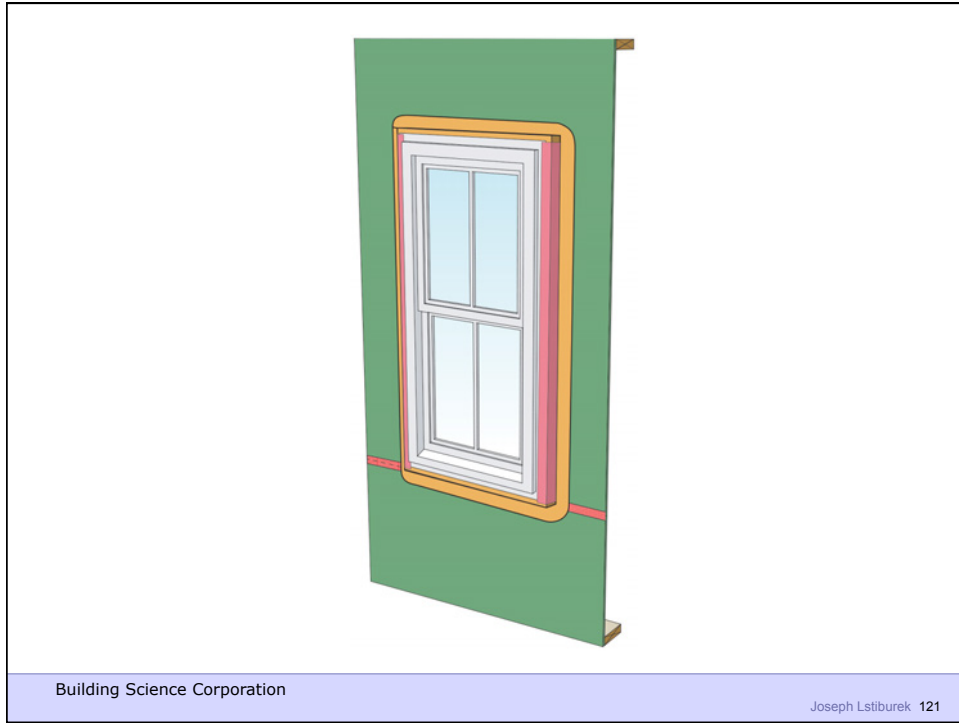

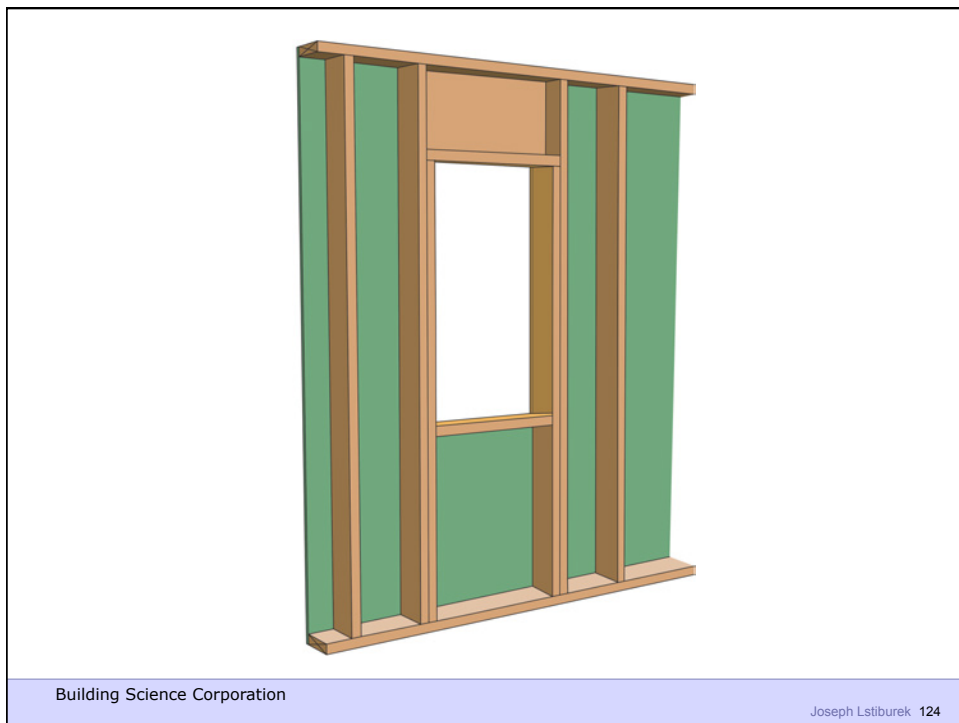
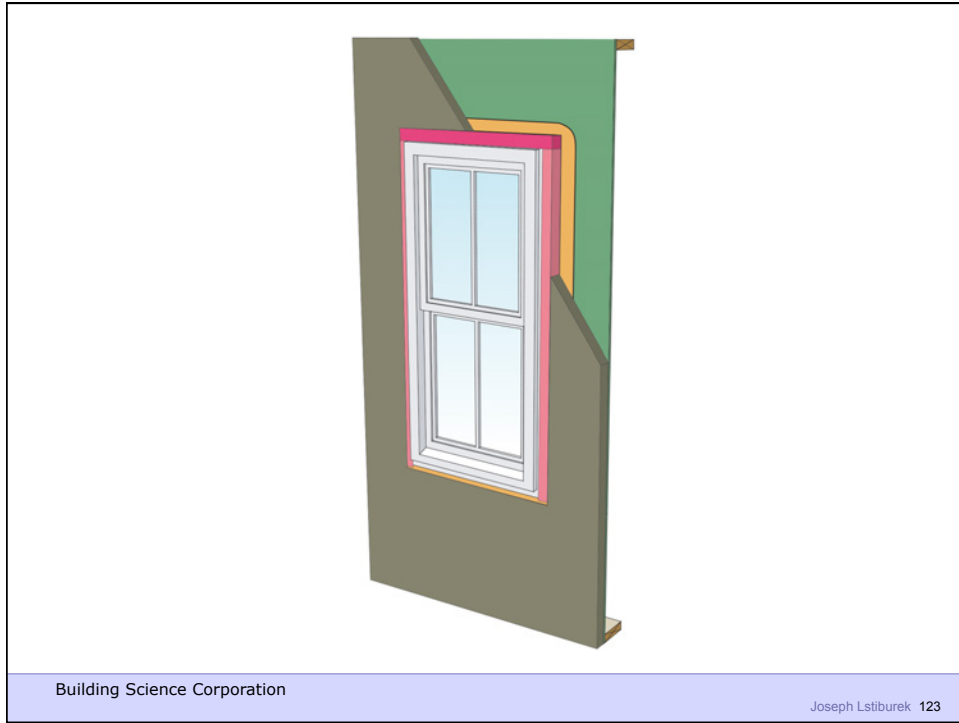

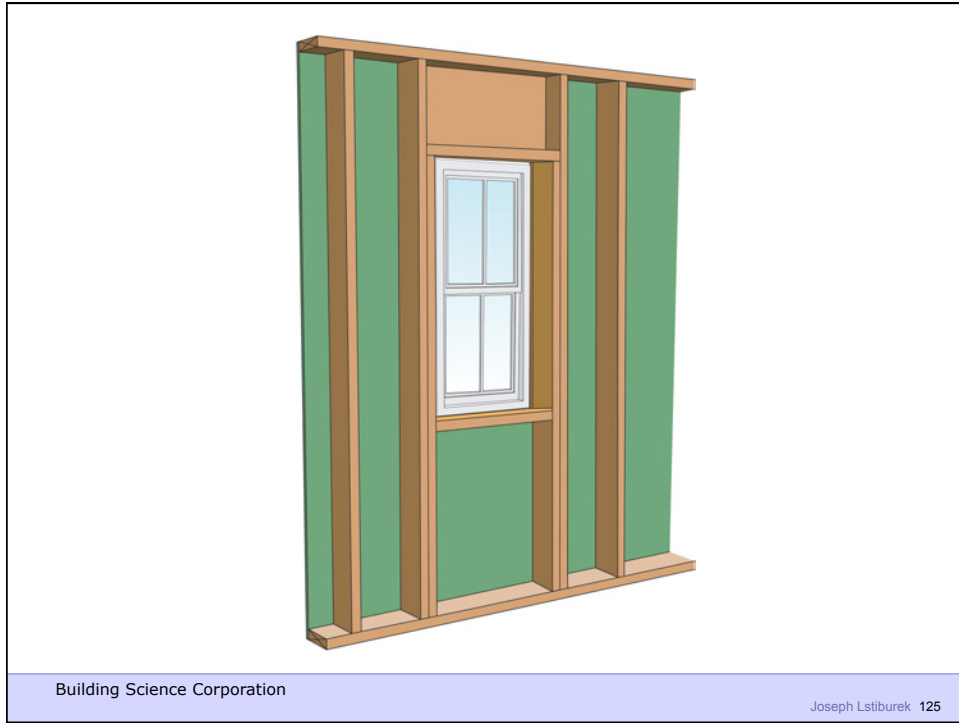

# Way Out There Outies

Building Science Corporation

Joseph Lstiburek 127

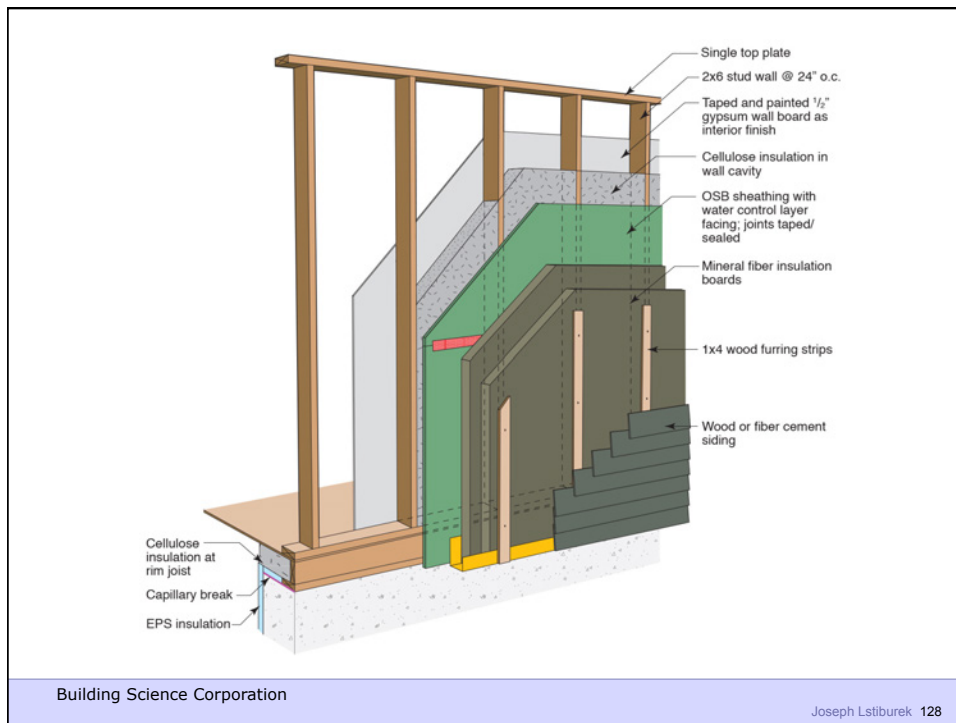

Building Science Corporation

Joseph Lstiburek 128



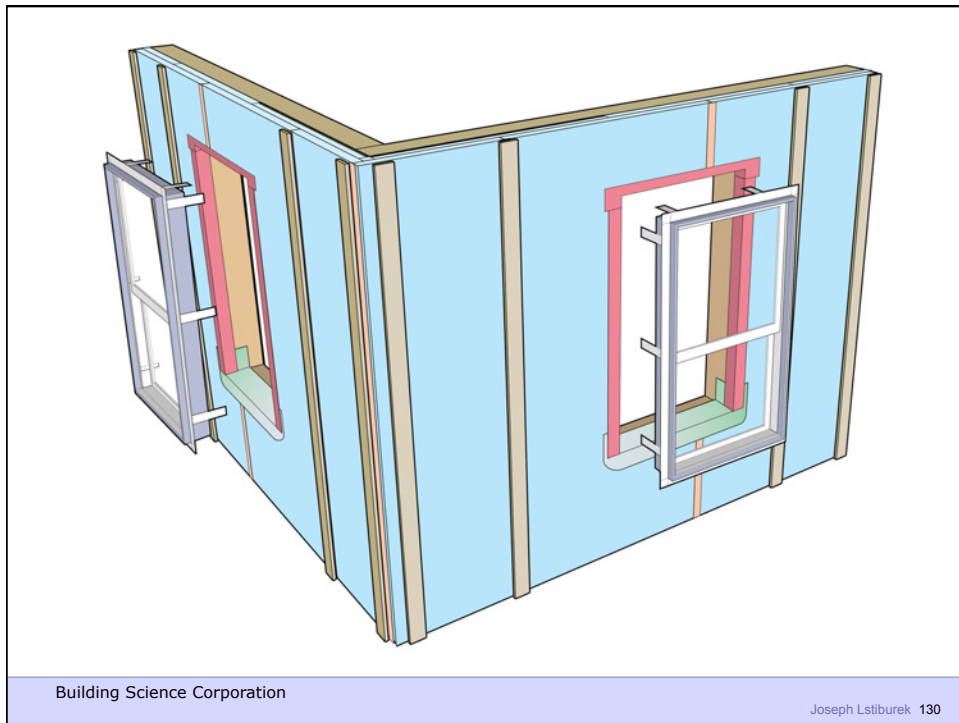
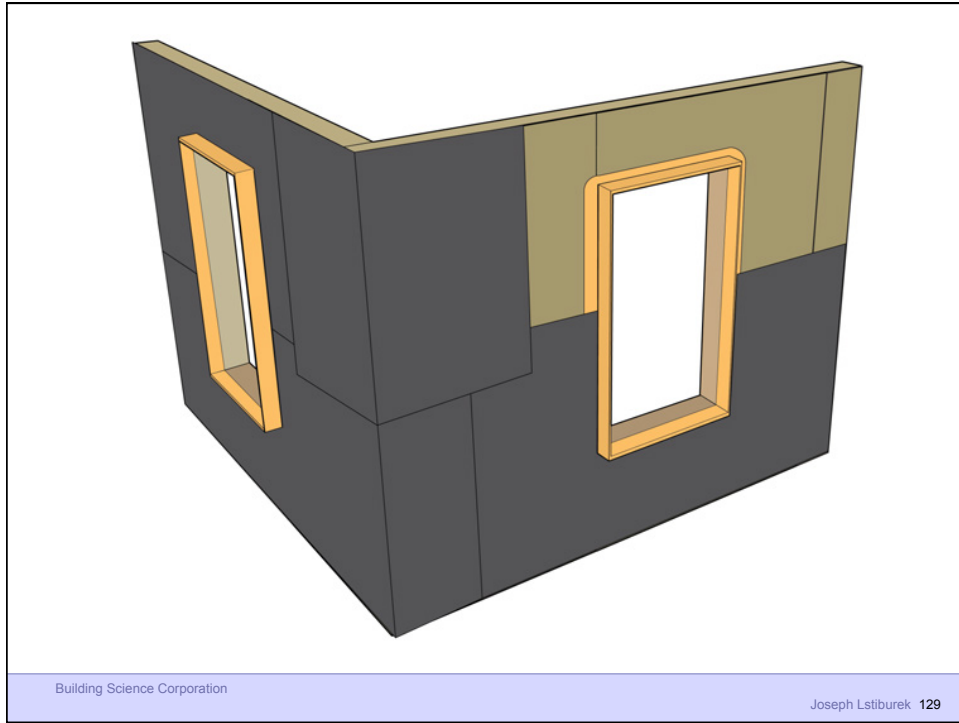

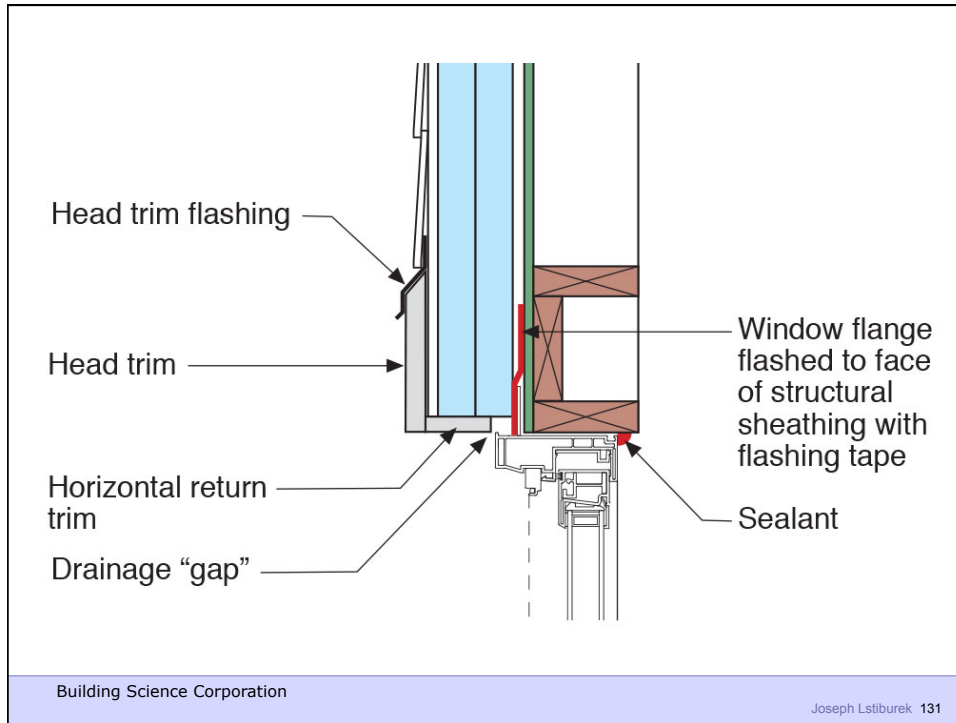



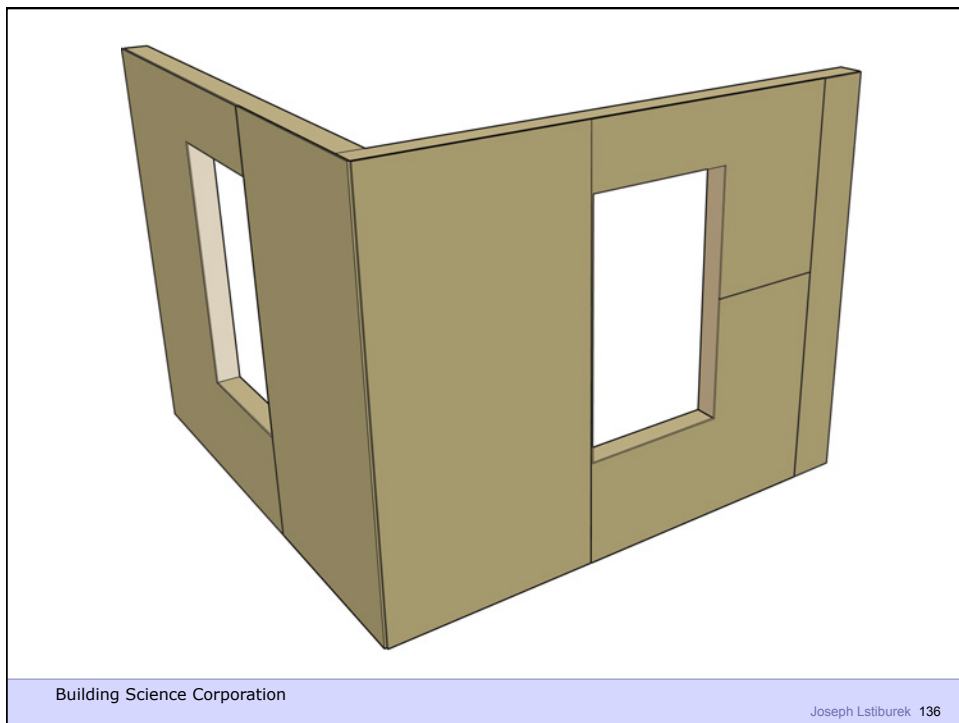
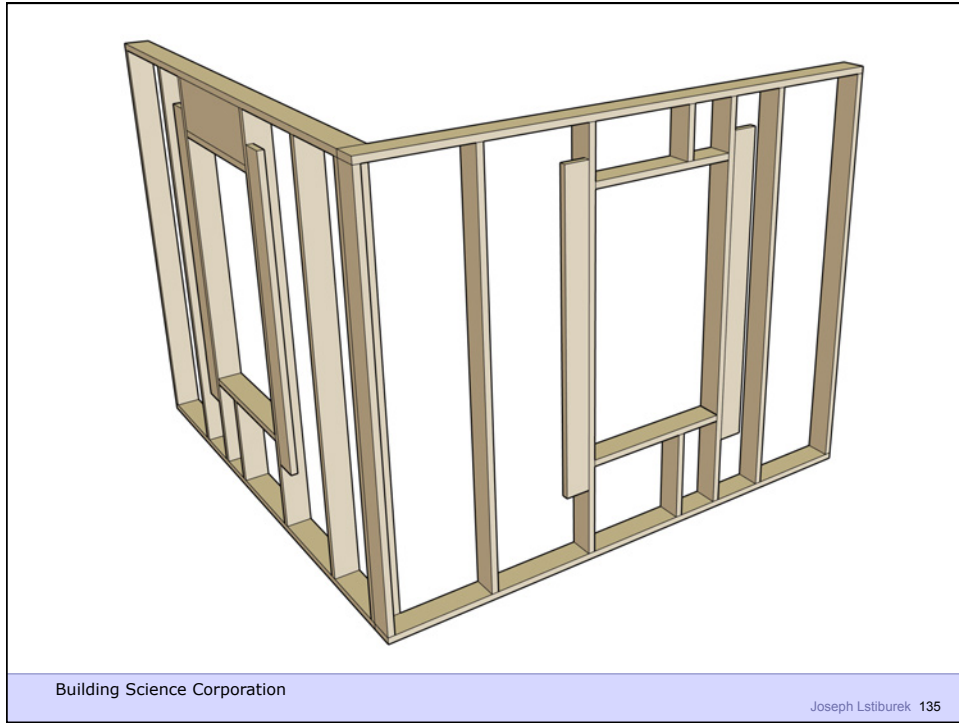

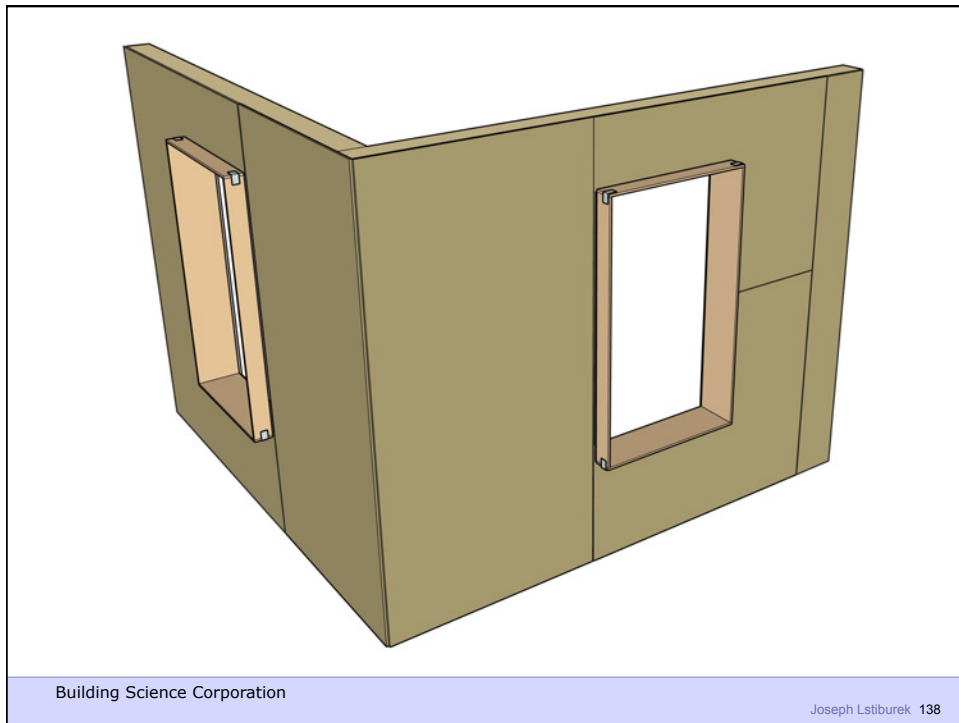
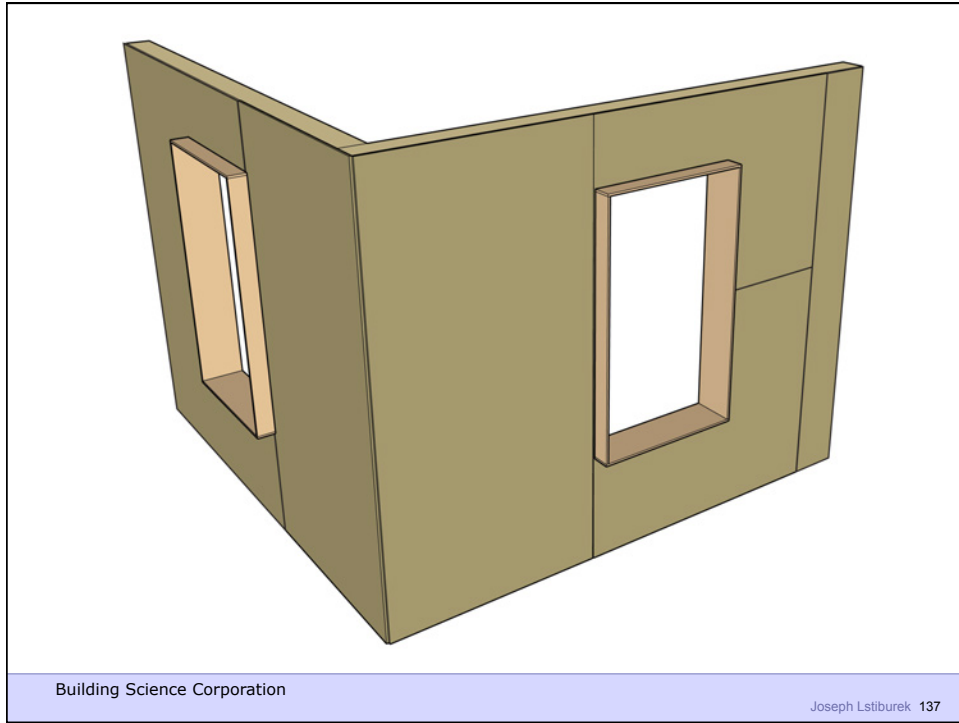

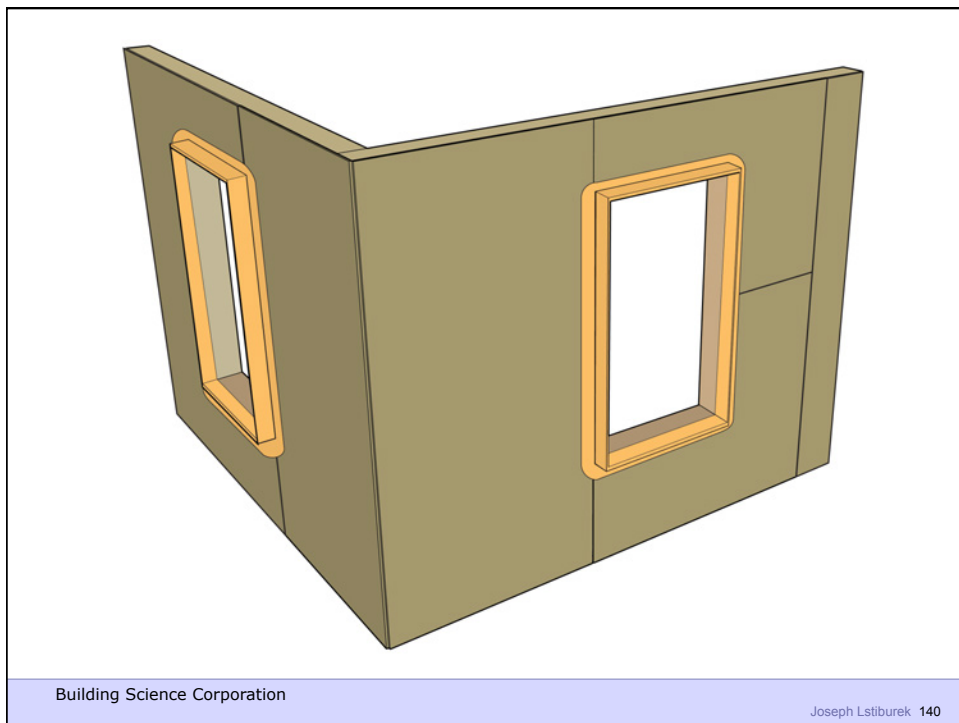
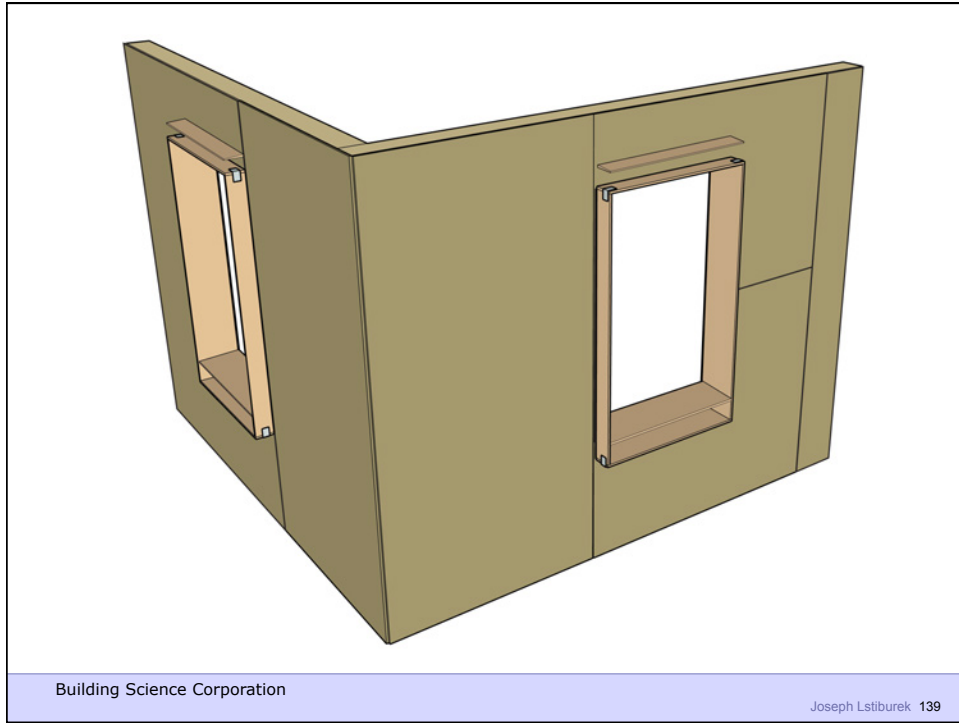

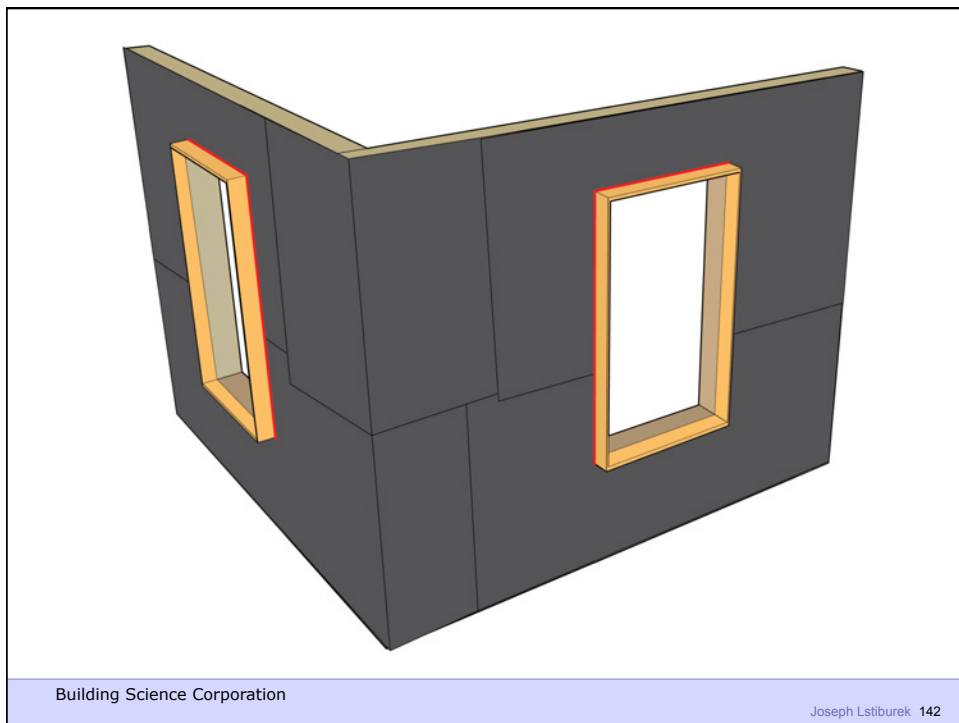
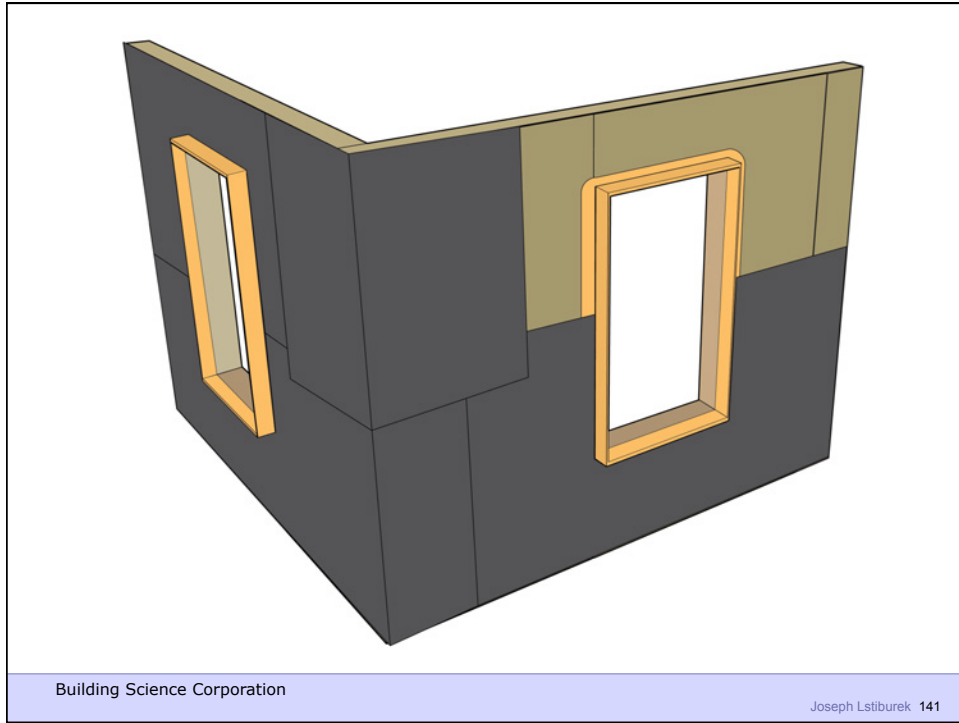

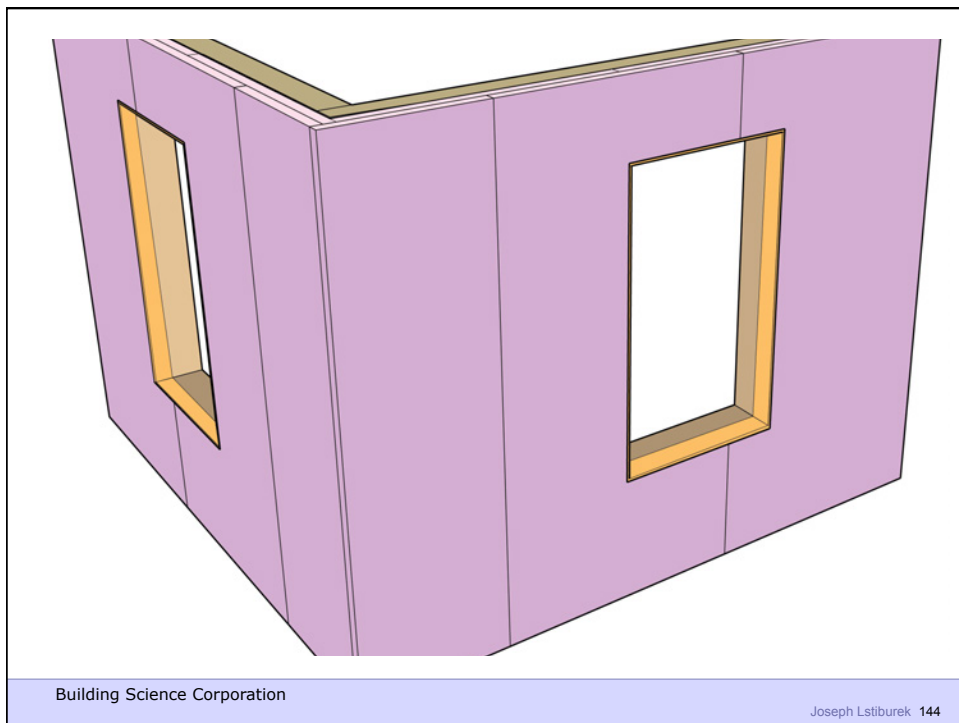
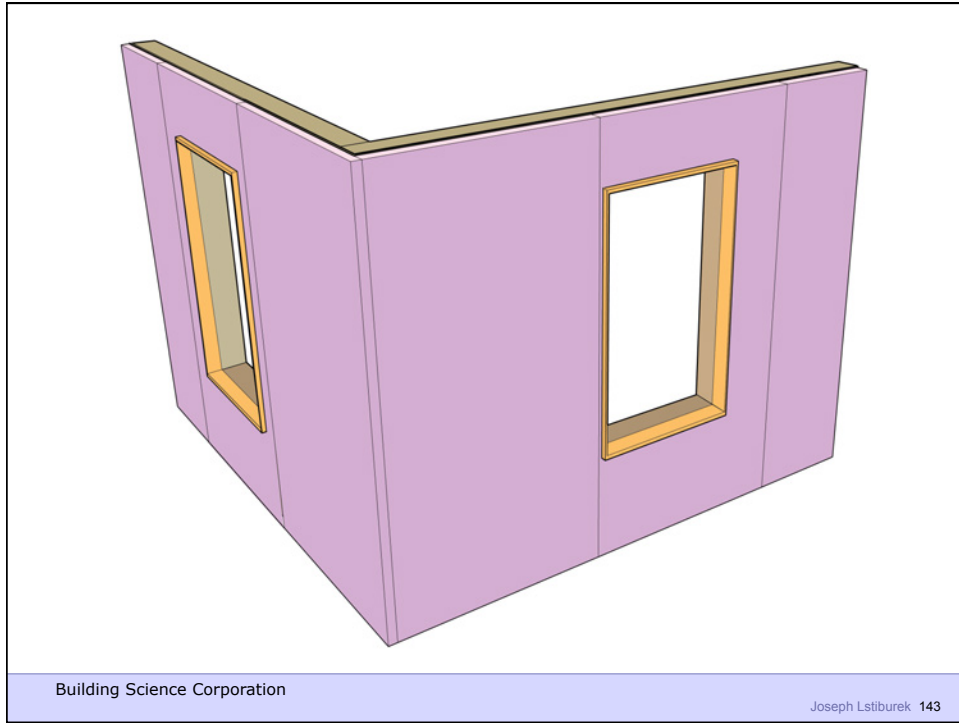



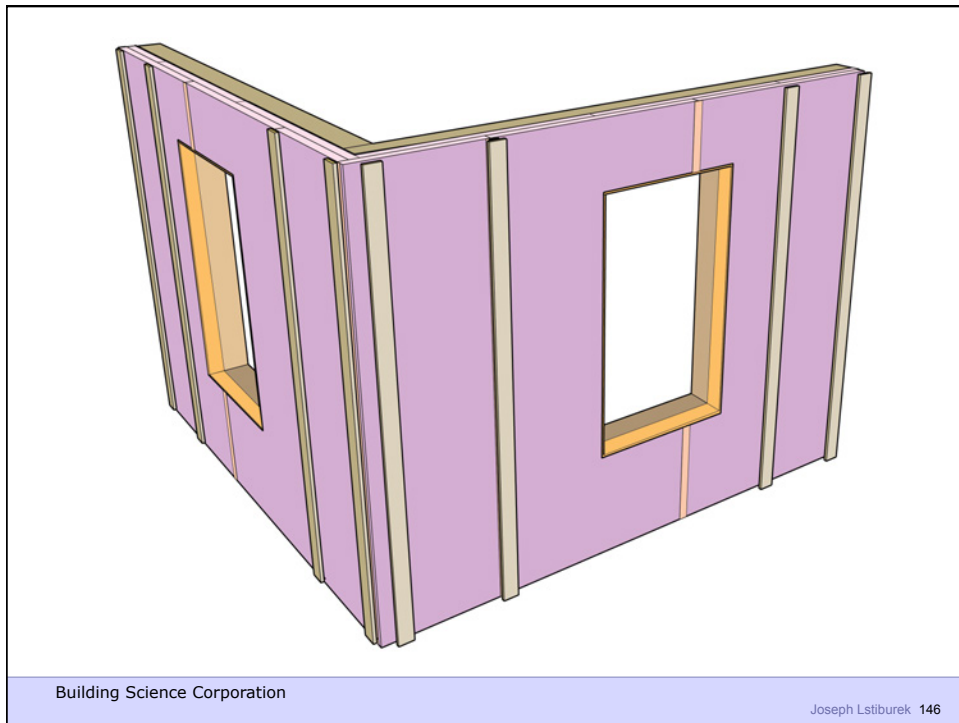
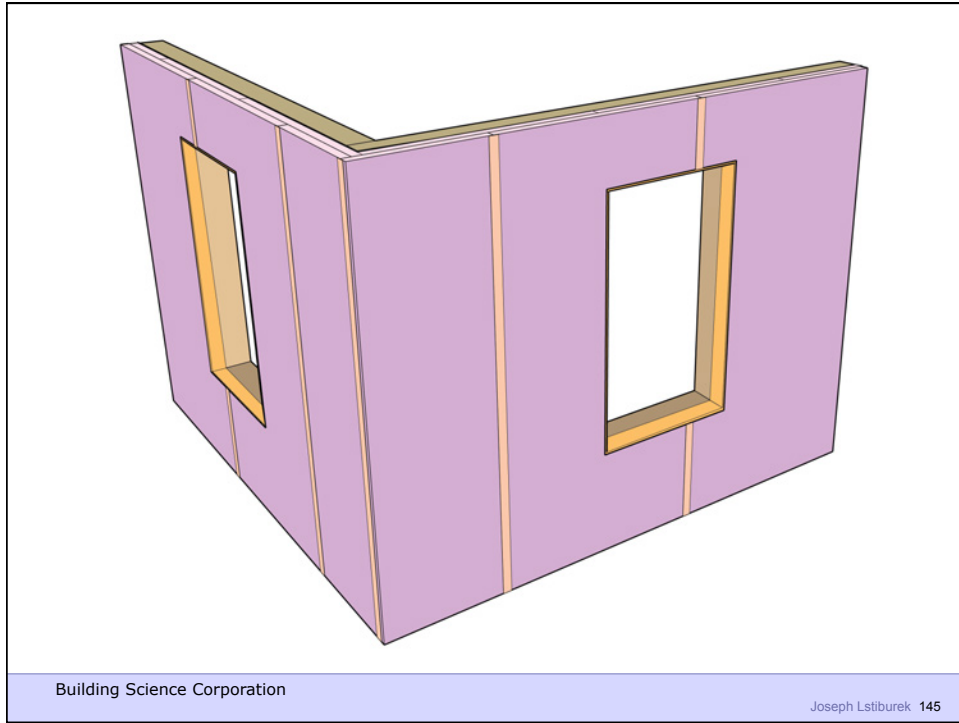

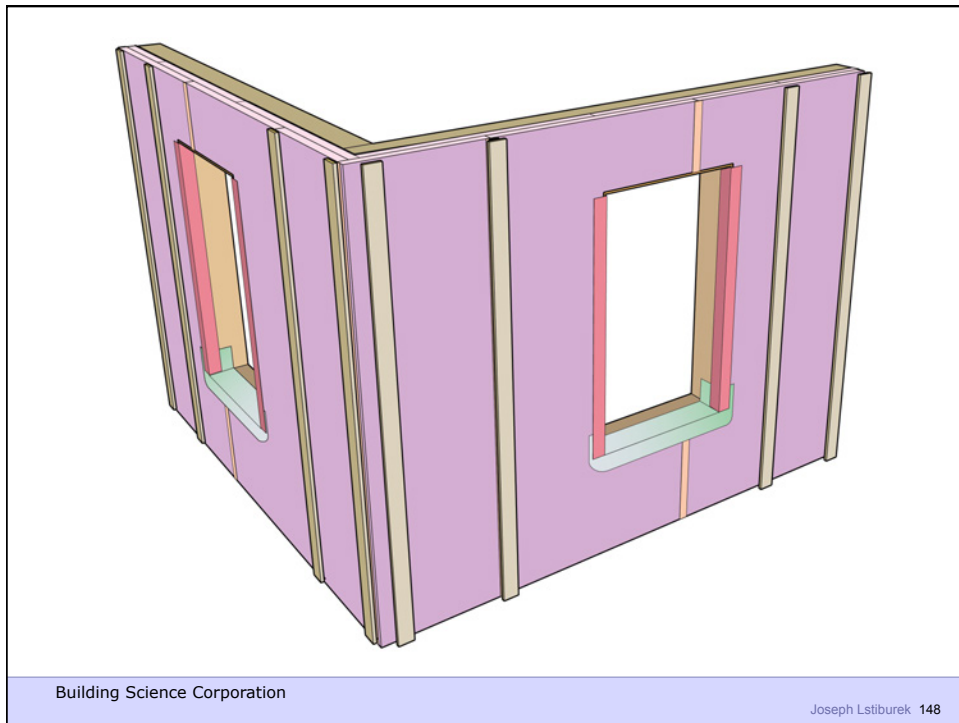
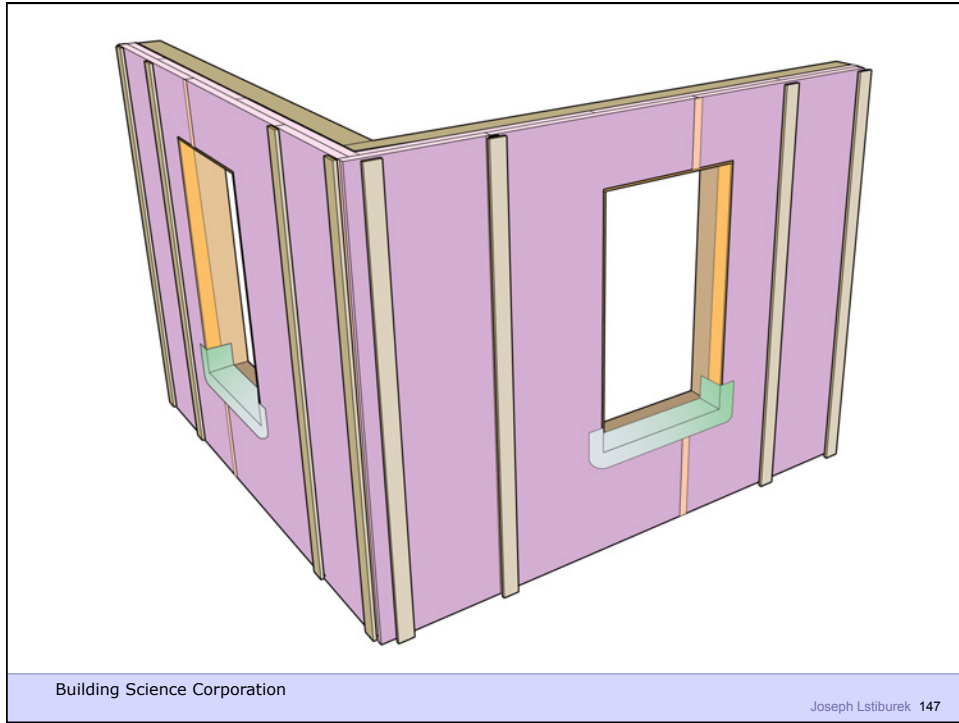

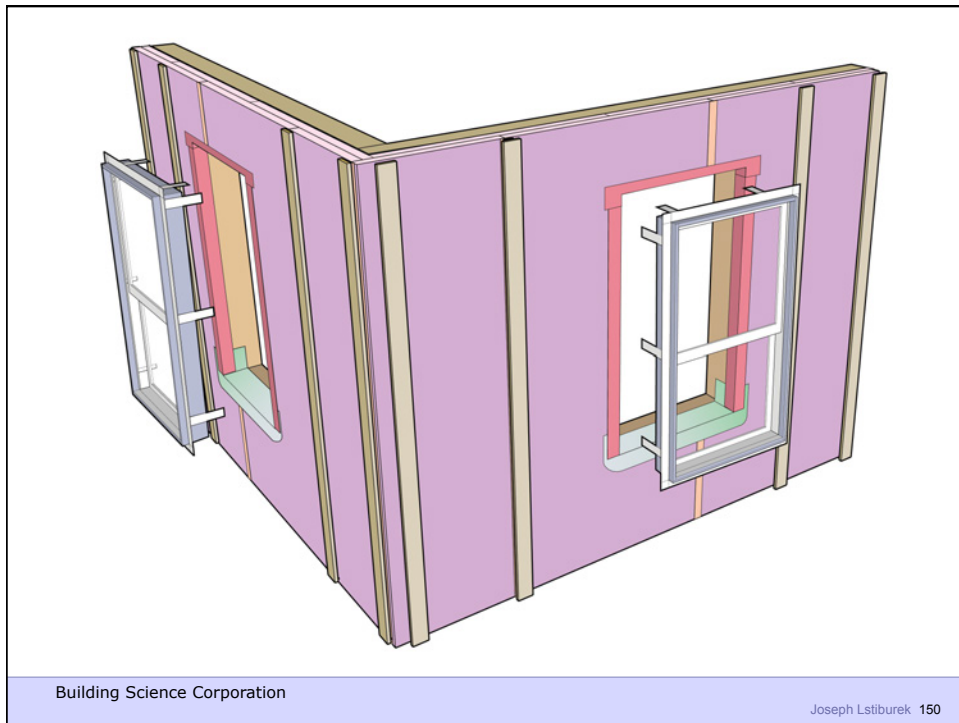
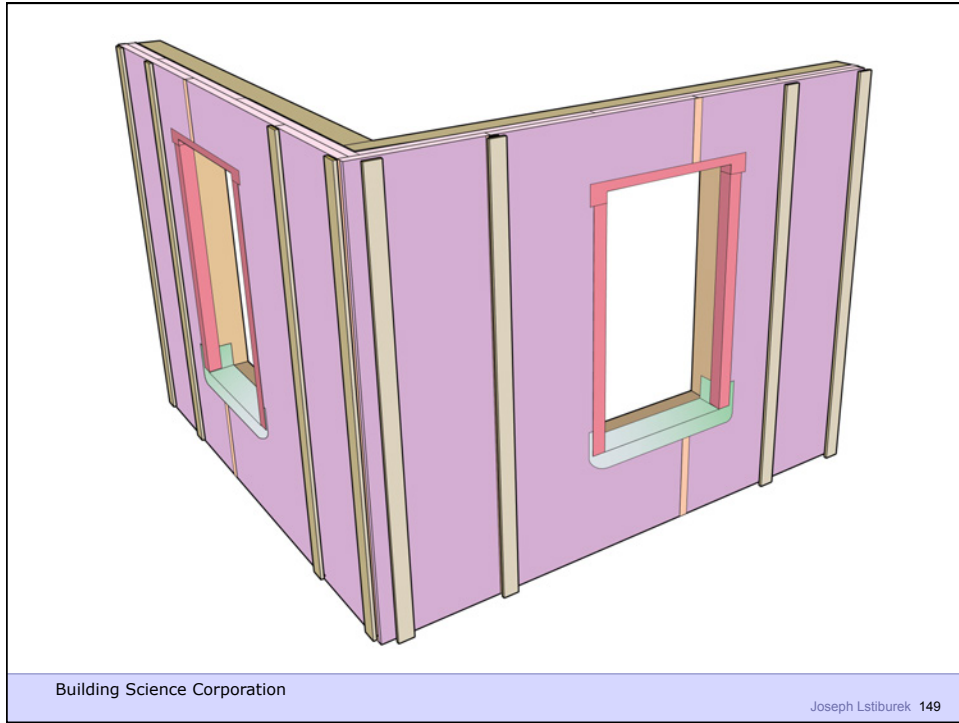

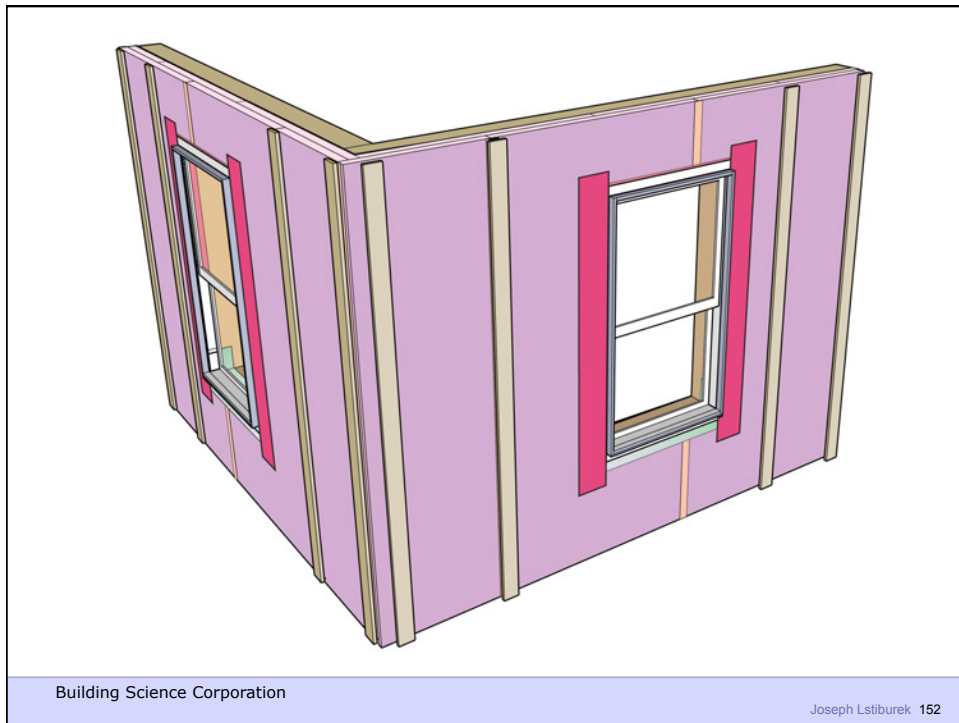
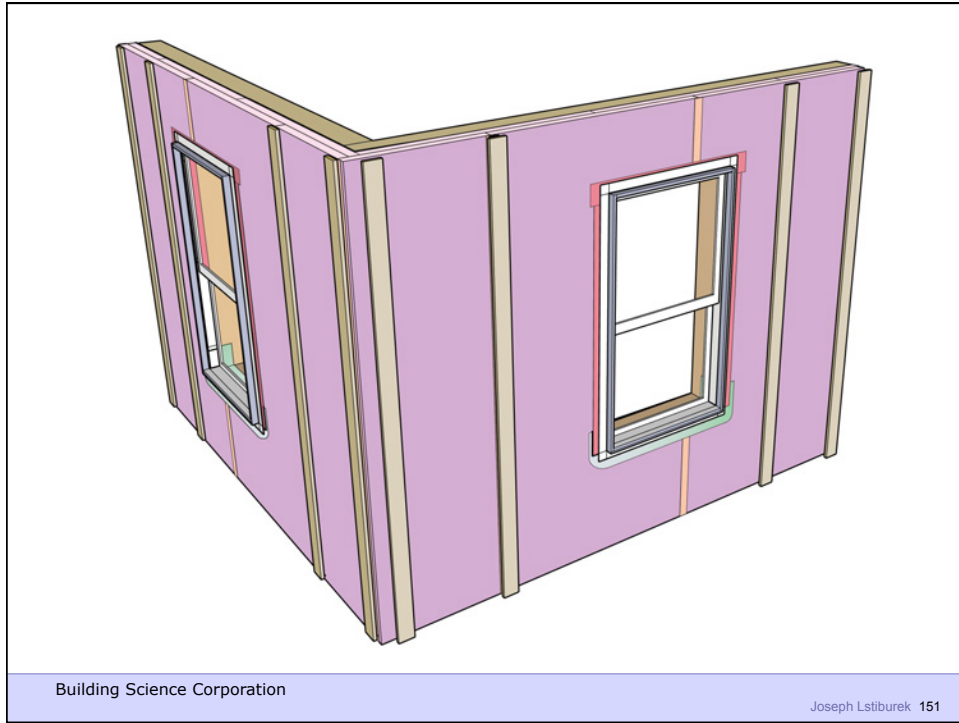

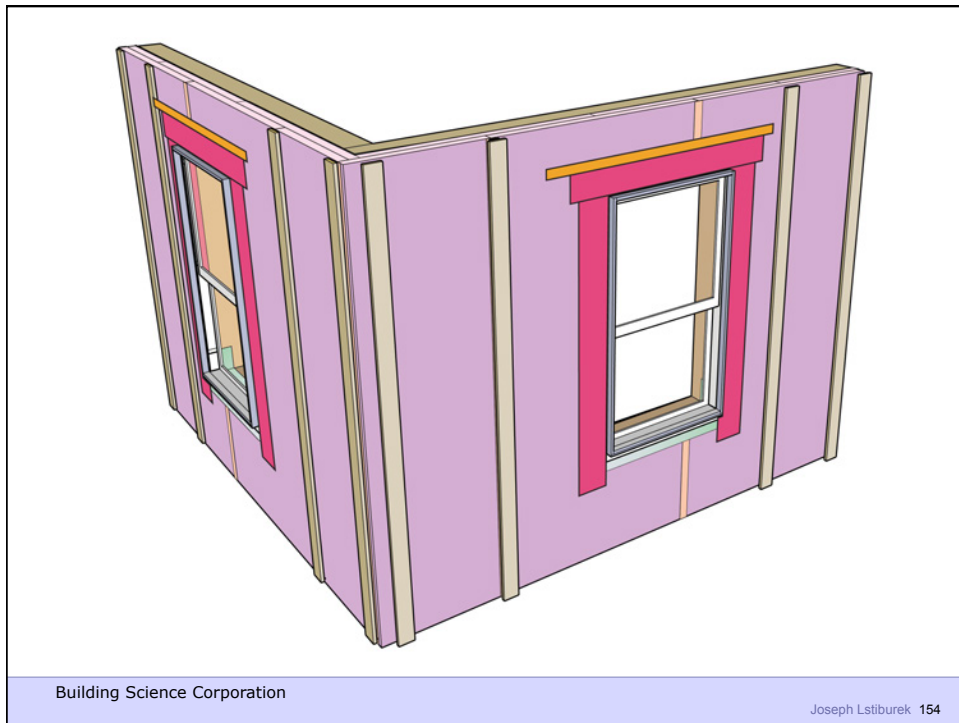
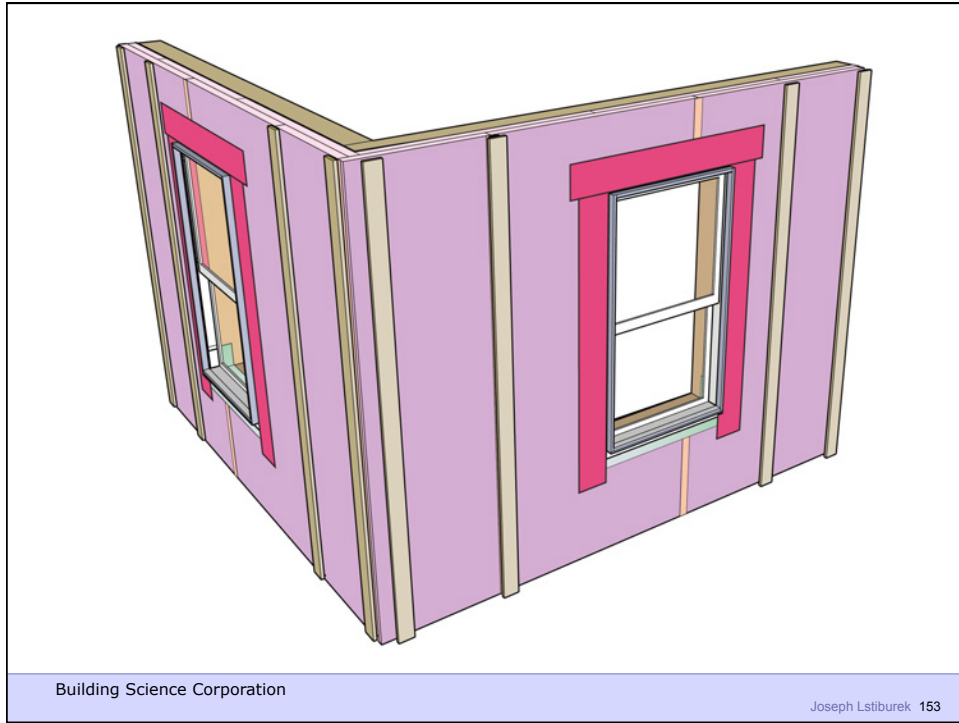

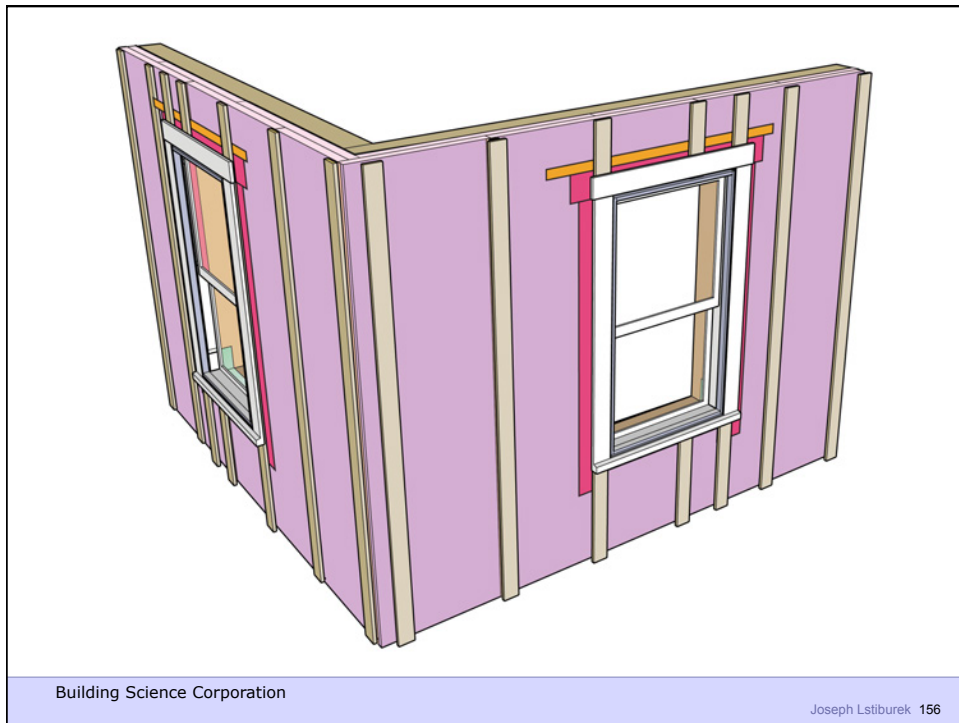
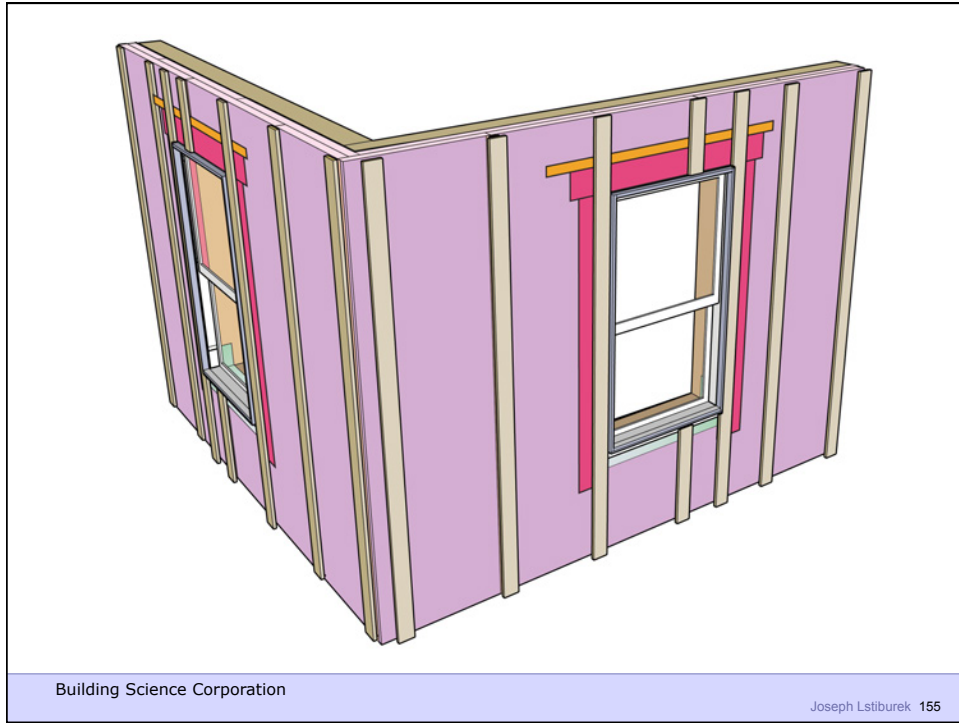

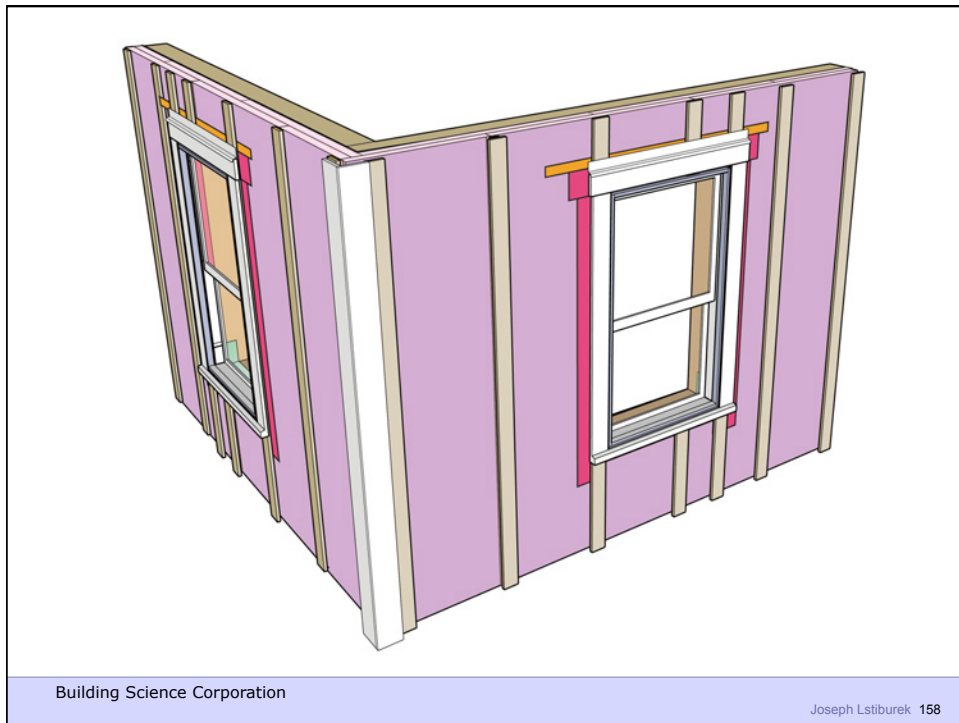
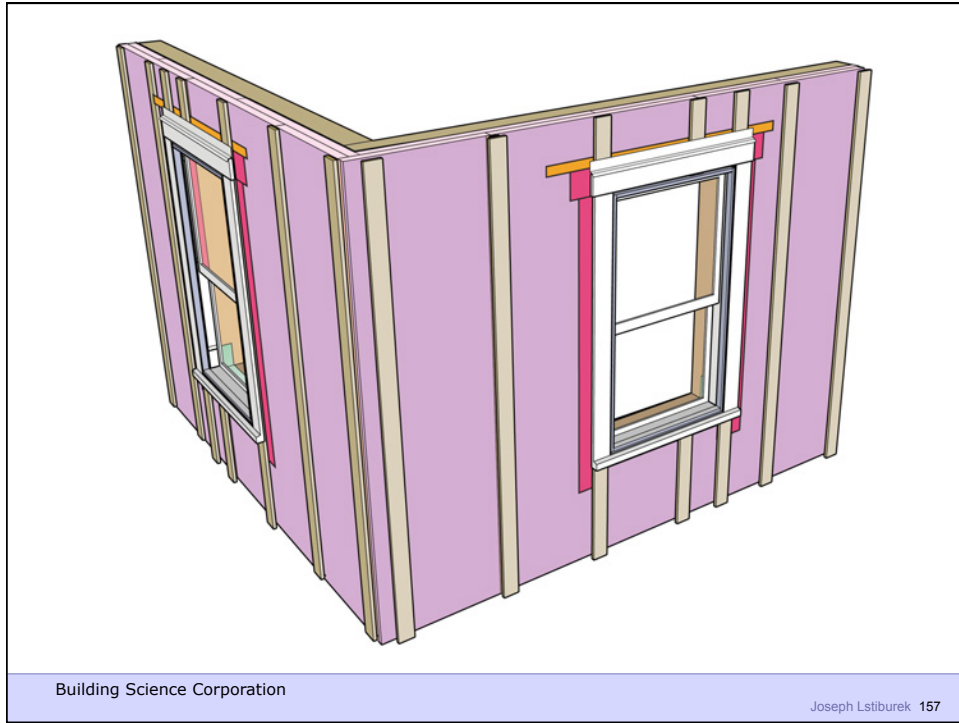

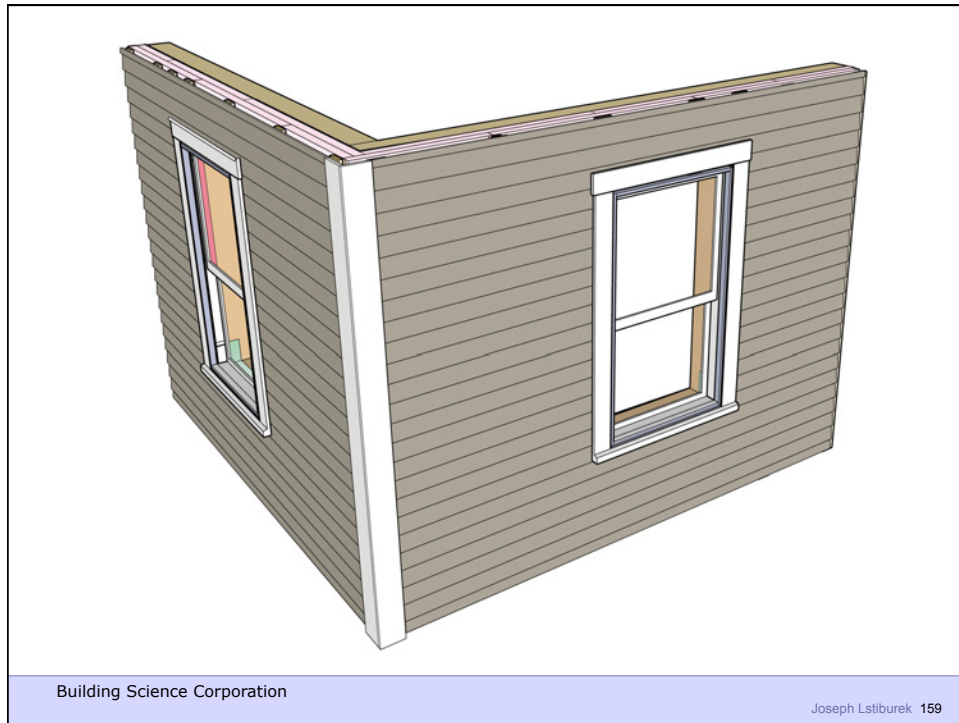

## Retrofit Innies

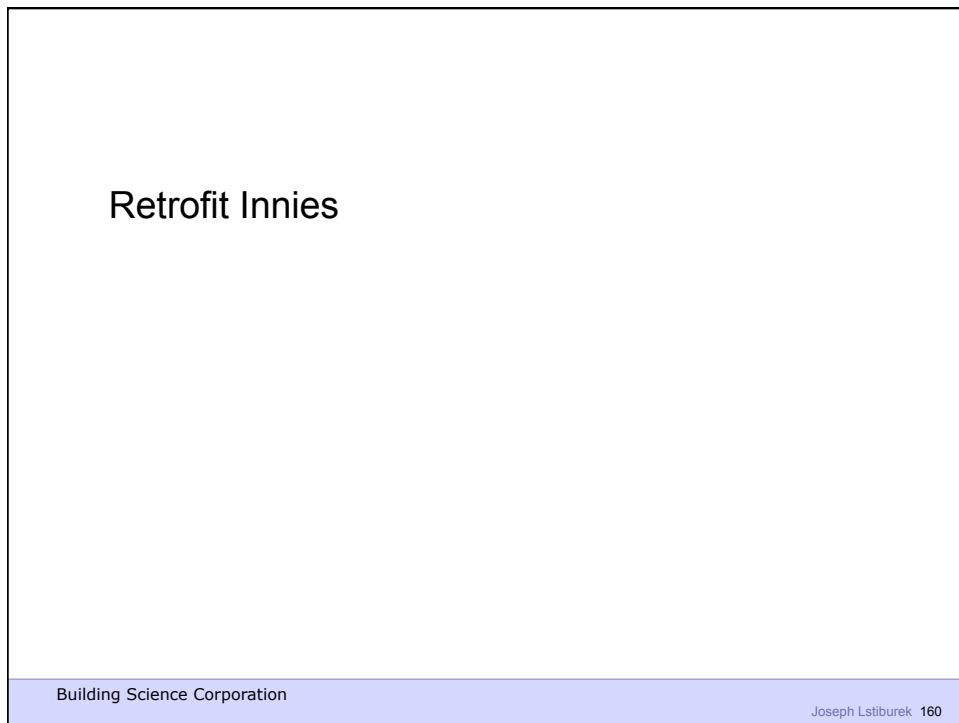





Building Science Corporation

Joseph Lstiburek 161



Building Science Corporation

Joseph Lstiburek 162





Building Science Corporation

Joseph Lstiburek 165



Building Science Corporation

Joseph Lstiburek 166



Building Science Corporation

Joseph Lstiburek 167



Building Science Corporation

Joseph Lstiburek 168



Building Science Corporation

Joseph Lstiburek 169



Building Science Corporation

Joseph Lstiburek 170



Building Science Corporation

Joseph Lstiburek 171



Building Science Corporation

Joseph Lstiburek 172





Building Science Corporation

Joseph Lstiburek 175



Building Science Corporation

Joseph Lstiburek 176





Building Science Corporation

Joseph Lstiburek 177



Building Science Corporation

Joseph Lstiburek 178

## My Place – Retrofit Outies

Building Science Corporation

Joseph Lstiburek 179



Building Science Corporation

Joseph Lstiburek 180

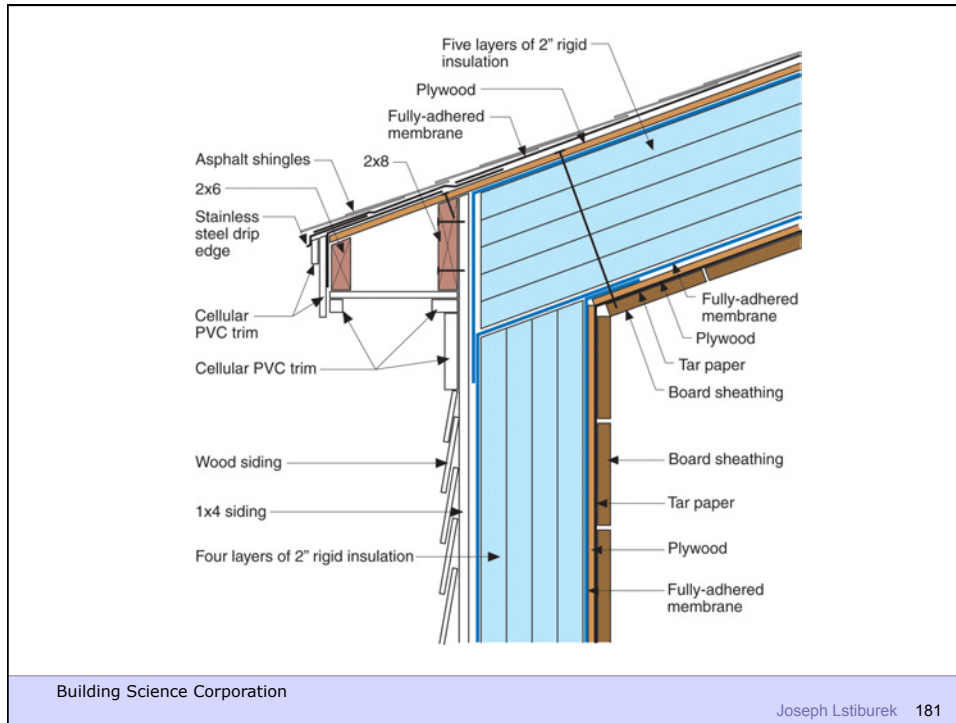

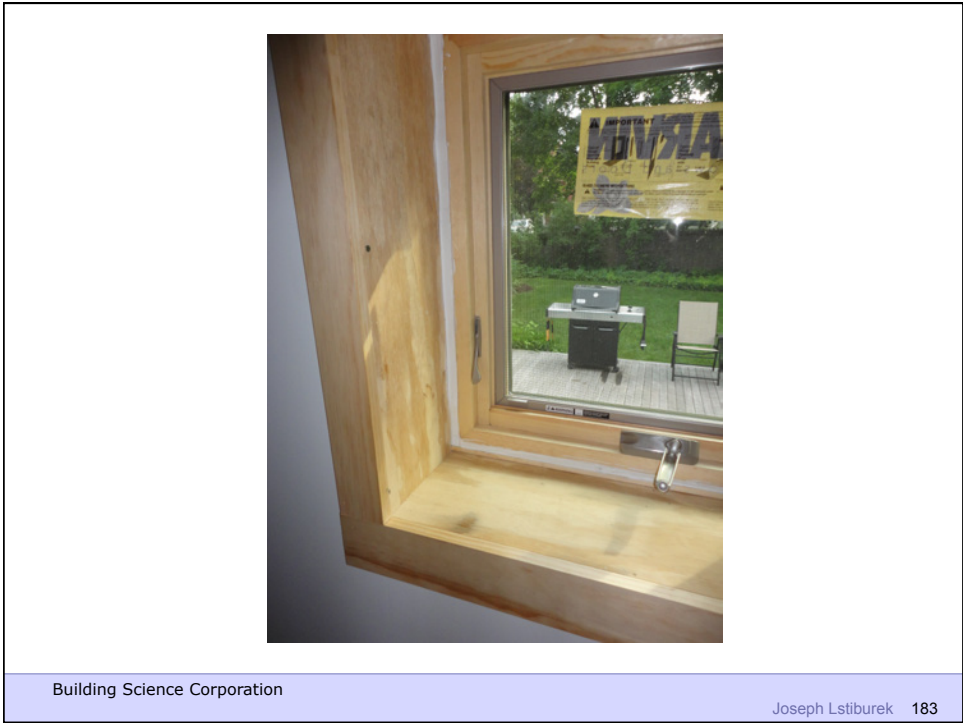



Building Science Corporation

Joseph Lstiburek 185

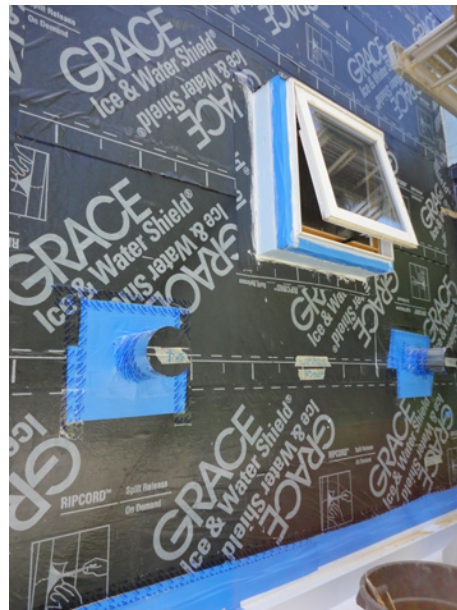

Building Science Corporation

Joseph Lstiburek 186



Building Science Corporation

Joseph Lstiburek 187



Building Science Corporation

Joseph Lstiburek 188



Building Science Corporation

Joseph Lstiburek 189



Building Science Corporation

Joseph Lstiburek - Walls and Windows 190