

Joseph Lstiburek, Ph.D., P.Eng, ASHRAE Fellow

Building Science

Adventures In Building Science

www.buildingscience.com

Life is Tough Enough As it Is...

Building Science Corporation Joseph Lstiburek 2

Life is Tough Enough As it Is...
It's Harder When You Are Stupid

Building Science Corporation Joseph Lstiburek 3

Don't Do Stupid Things

Building Science Corporation Joseph Lstiburek 4



Building Science Corporation

Joseph Lstiburek 5



Building Science Corporation

Joseph Lstiburek 6



Building Science Corporation

Joseph Lstiburek 7



Building Science Corporation

Joseph Lstiburek 8

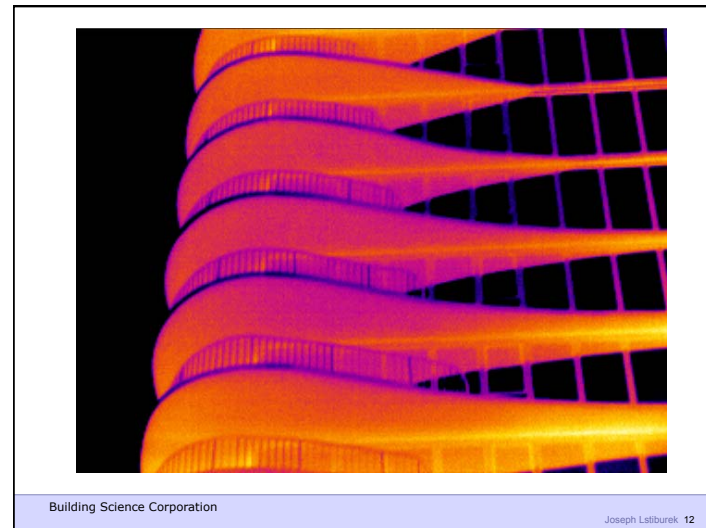
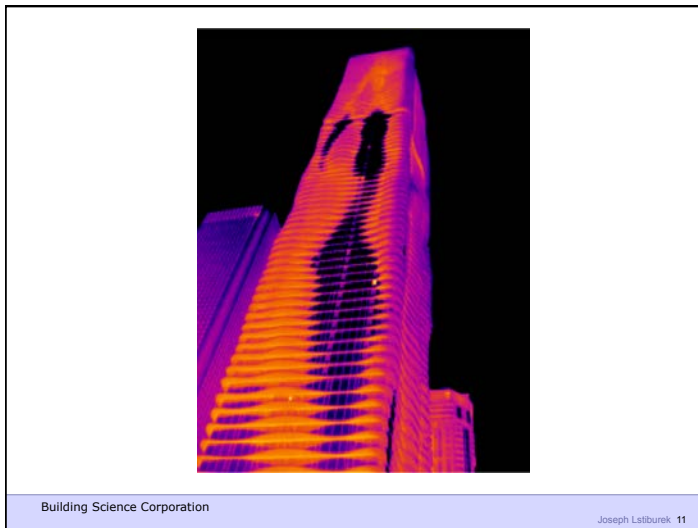
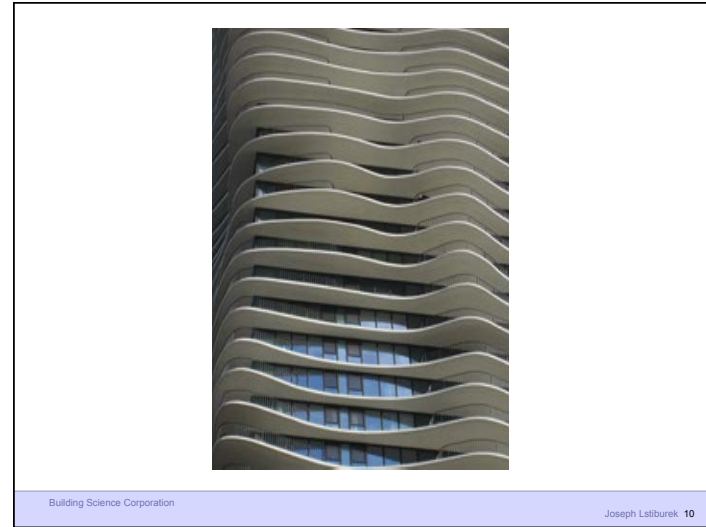

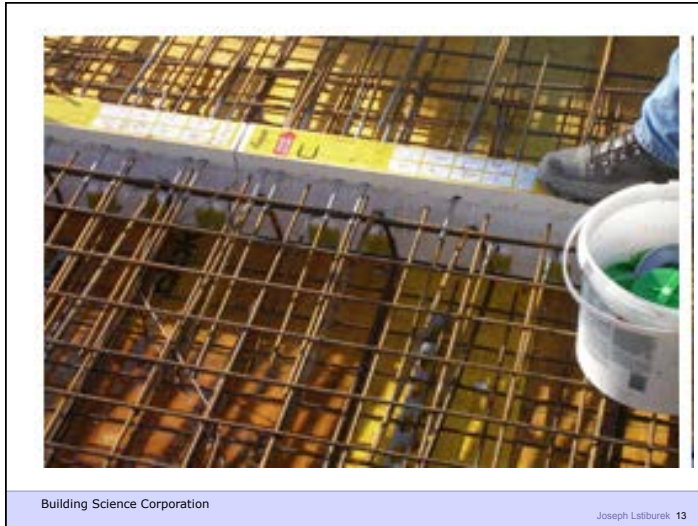

Building Science Corporation

Joseph Lstiburek 13

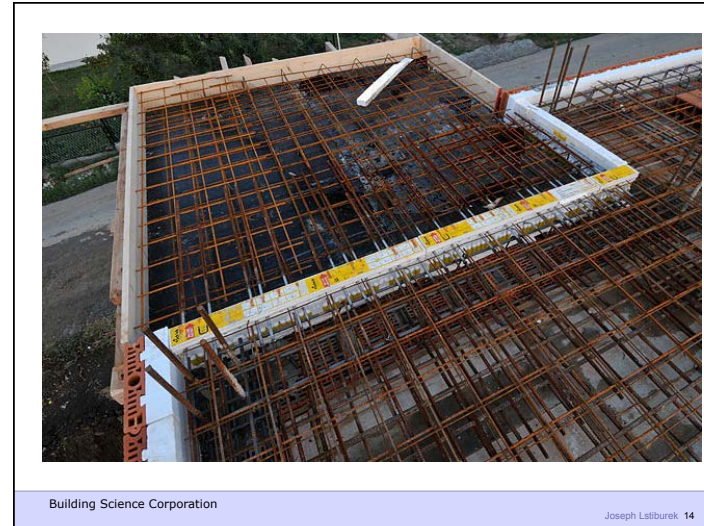

Building Science Corporation

Joseph Lstiburek 14

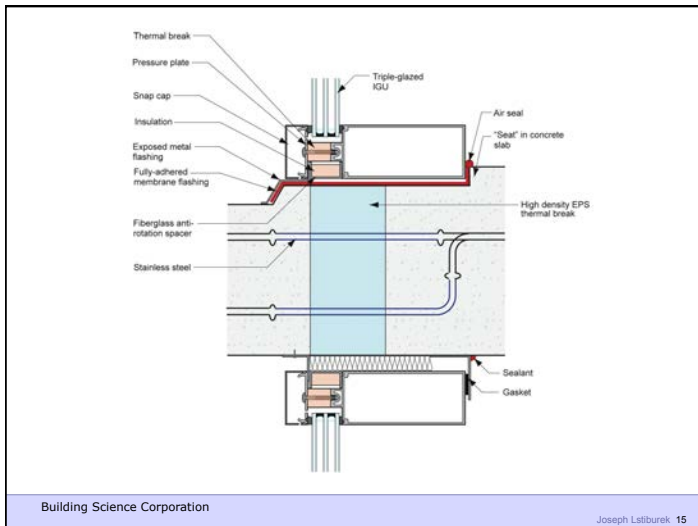

Building Science Corporation

Joseph Lstiburek 15

What is a Building?

Building Science Corporation

Joseph Lstiburek 16

A Building is an Environmental Separator

Building Science Corporation

Joseph Lstiburek 17

- Control heat flow
- Control airflow
- Control water vapor flow
- Control rain
- Control ground water
- Control light and solar radiation
- Control noise and vibrations
- Control contaminants, environmental hazards and odors
- Control insects, rodents and vermin
- Control fire
- Provide strength and rigidity
- Be durable
- Be aesthetically pleasing
- Be economical

Building Science Corporation

Joseph Lstiburek 18

Heat Flow Is From Warm To Cold
Moisture Flow Is From Warm To Cold
Moisture Flow Is From More To Less
Air Flow Is From A Higher Pressure to a
Lower Pressure
Gravity Acts Down

Building Science Corporation

Joseph Lstiburek 19

Water Control Layer
Air Control Layer
Vapor Control Layer
Thermal Control Layer

Building Science Corporation

Joseph Lstiburek 20

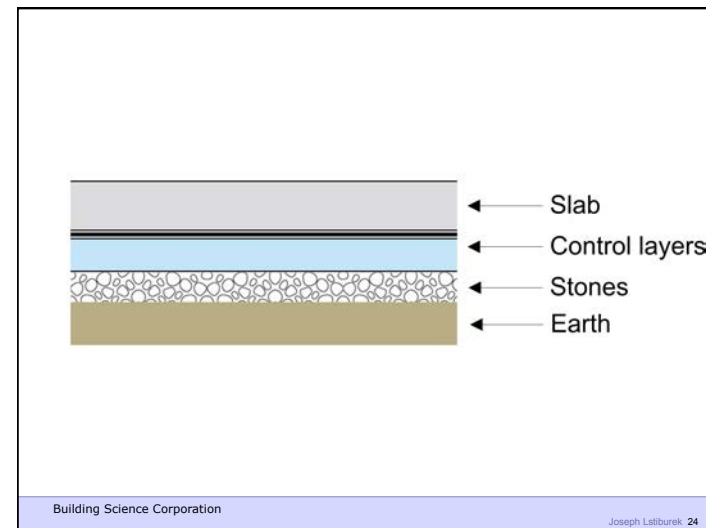
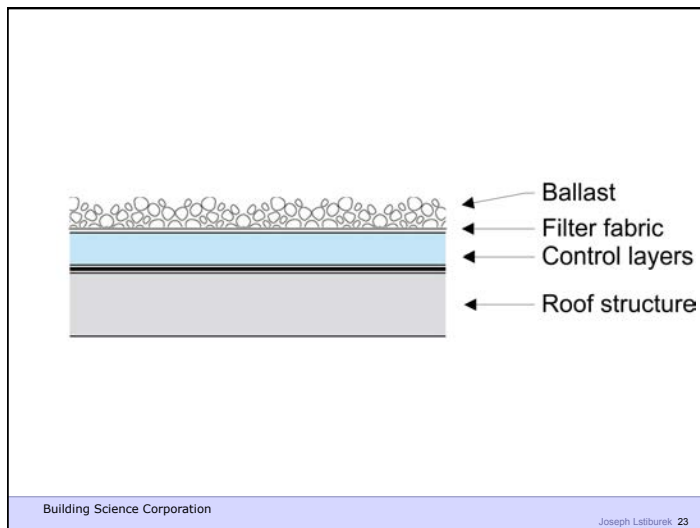
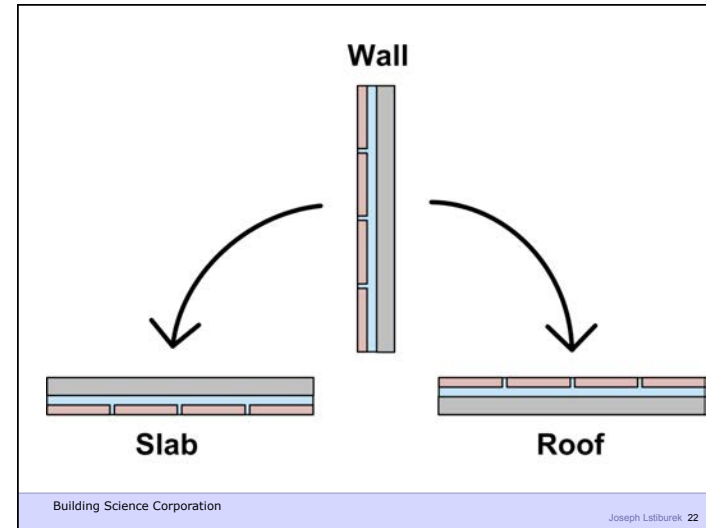
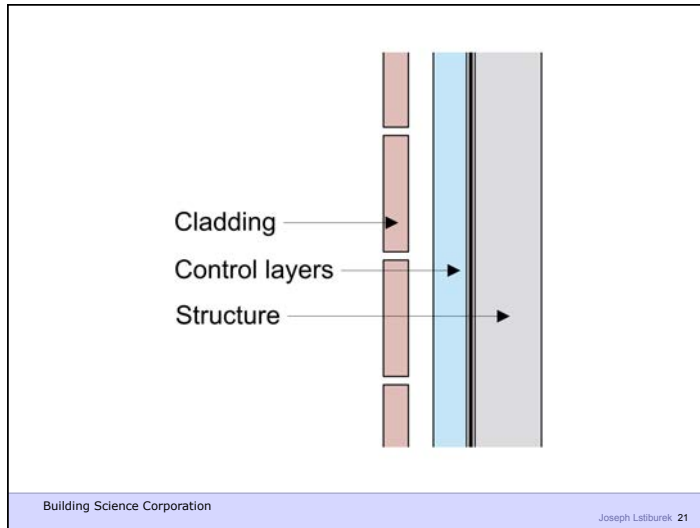

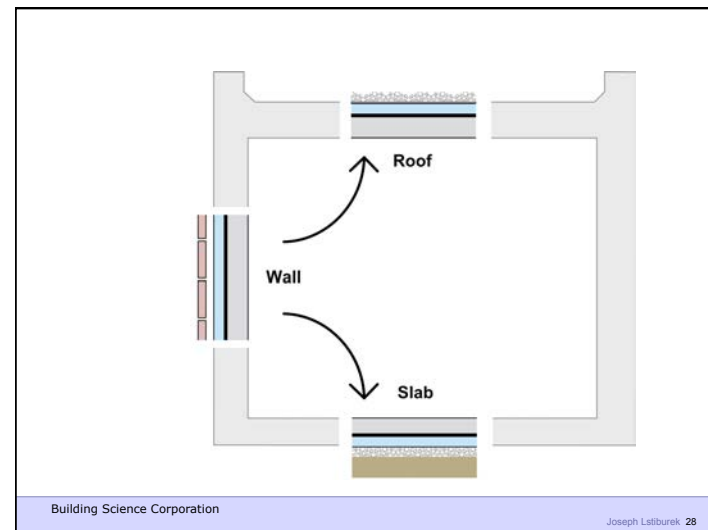
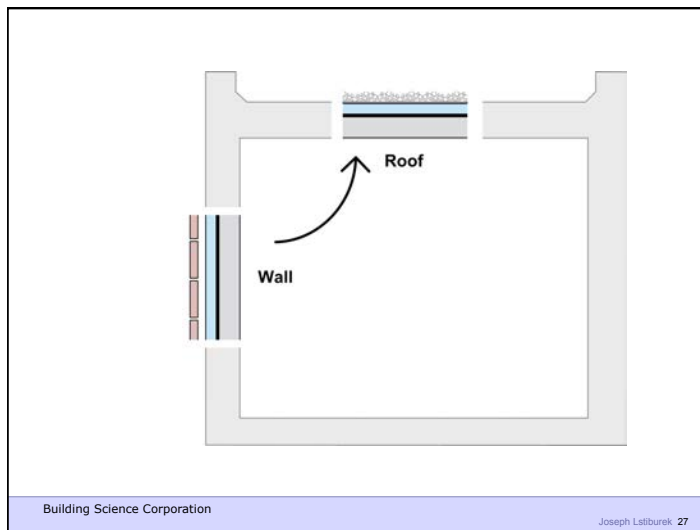
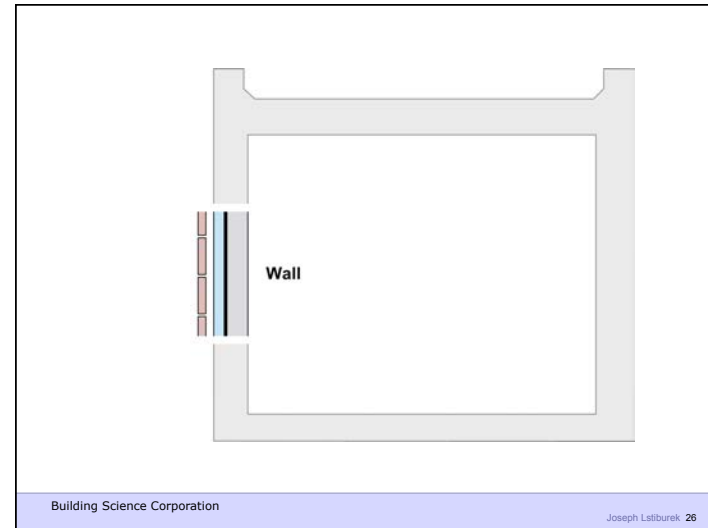
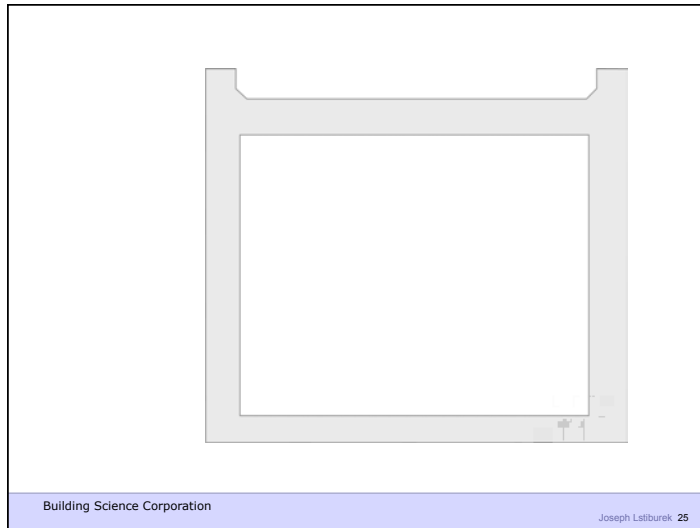

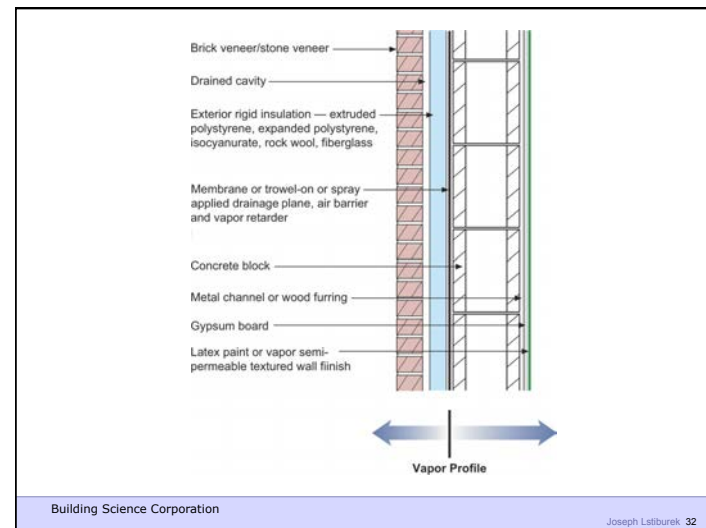
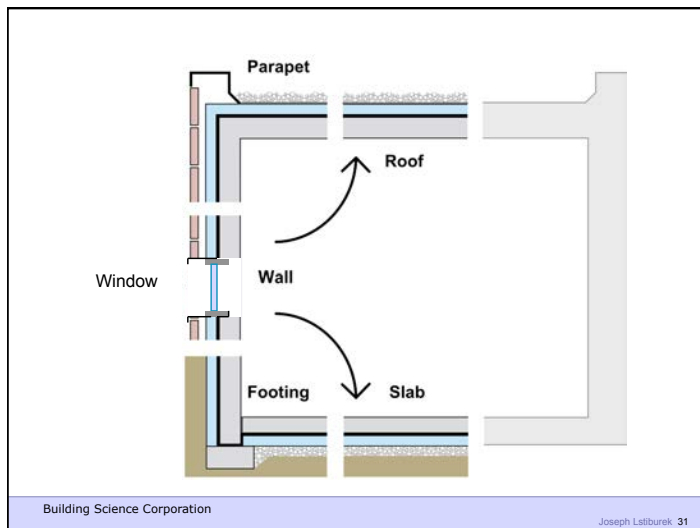
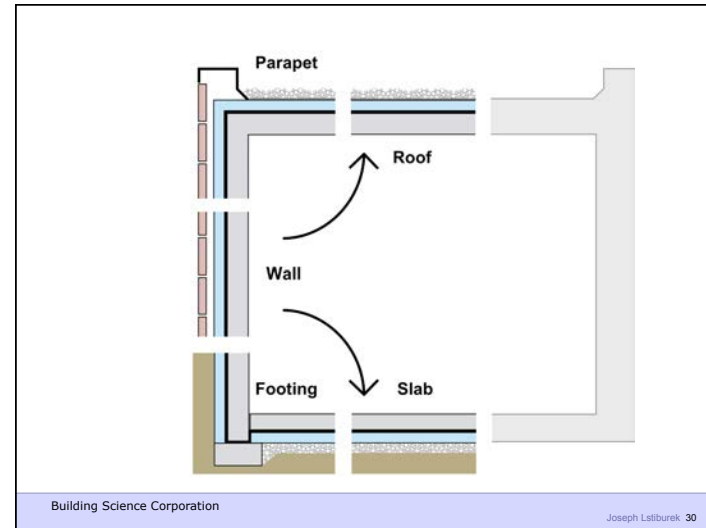
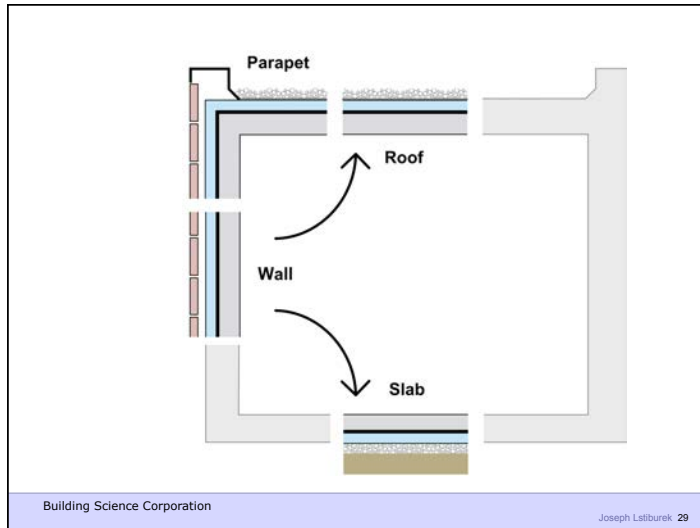

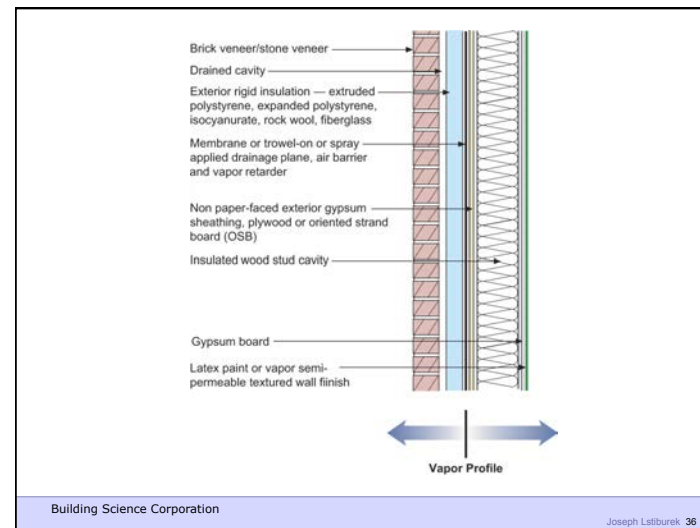
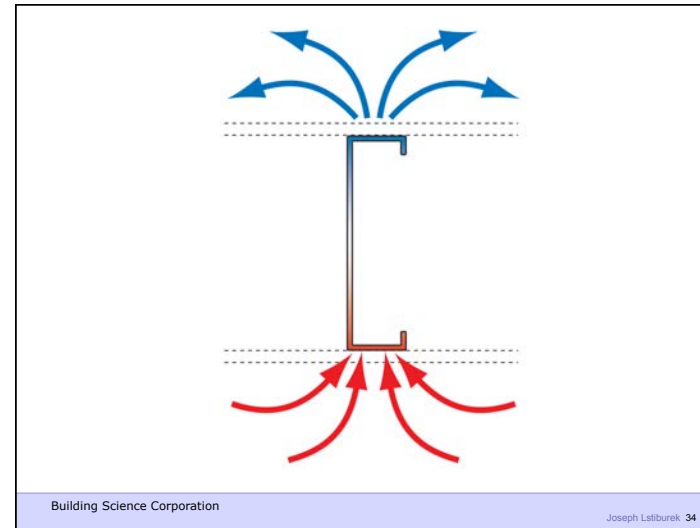
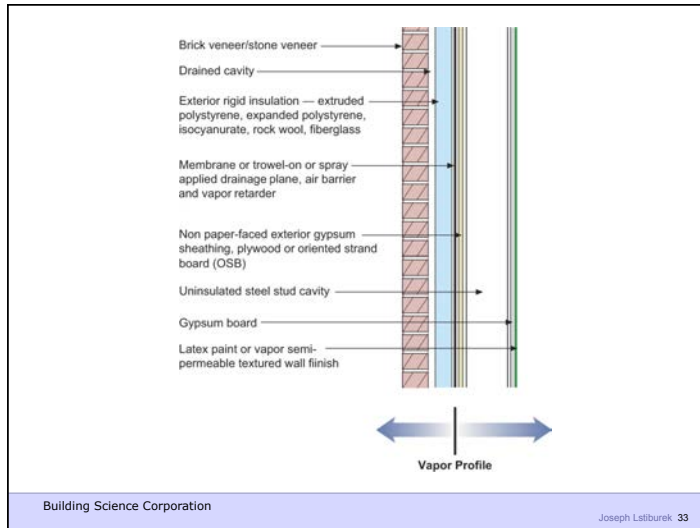

Commercial Enclosure: Simple Layers

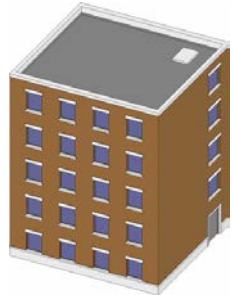

- Structure
- Rain/Air/Vapor
- Insulation
- Finish

Building Science Corporation

Joseph Lstiburek 37

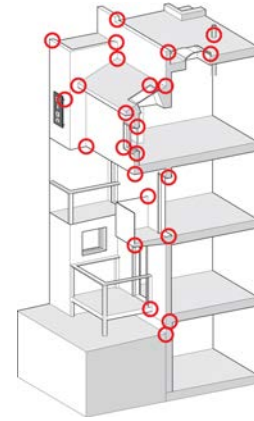

Building Science Corporation

Joseph Lstiburek 38



Building Science Corporation

Joseph Lstiburek 39



Building Science Corporation

Joseph Lstiburek 40

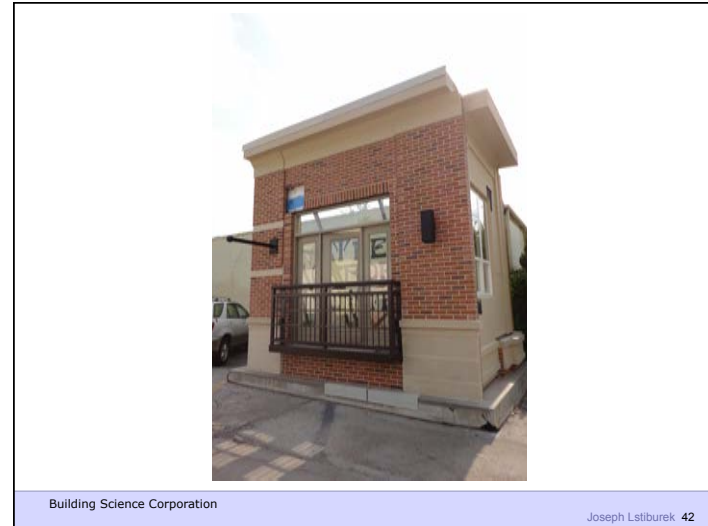

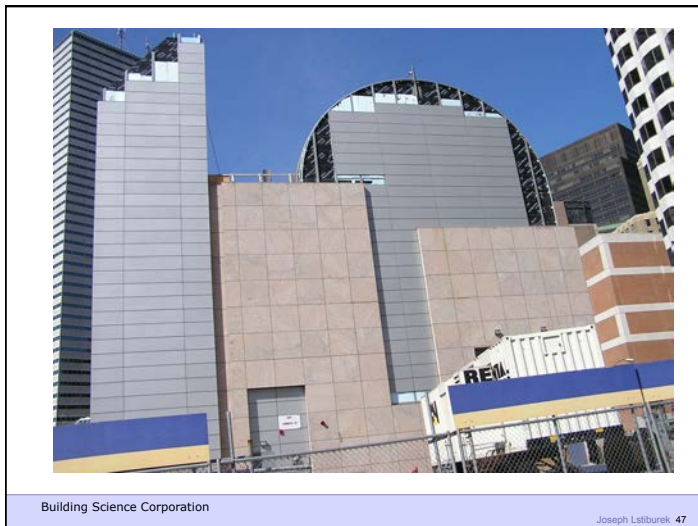

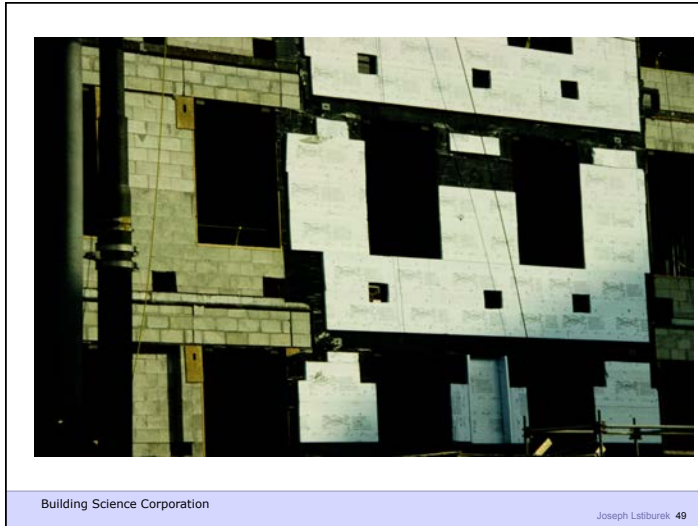

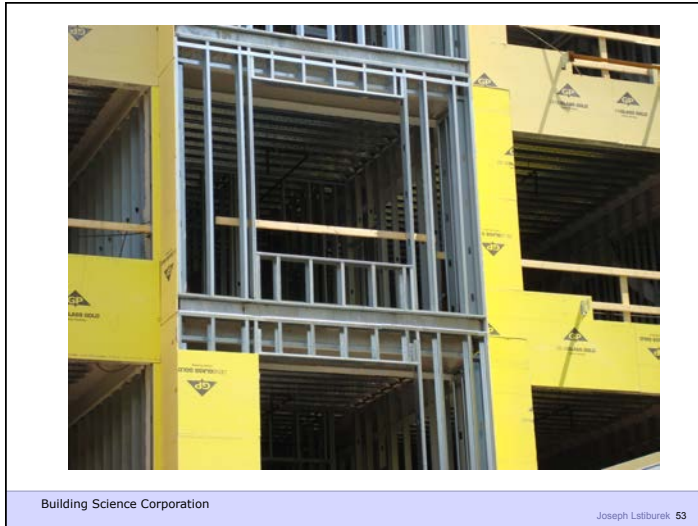

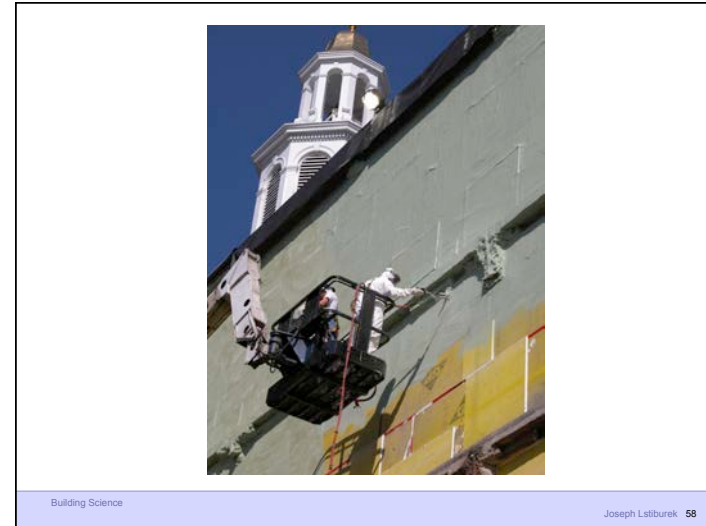

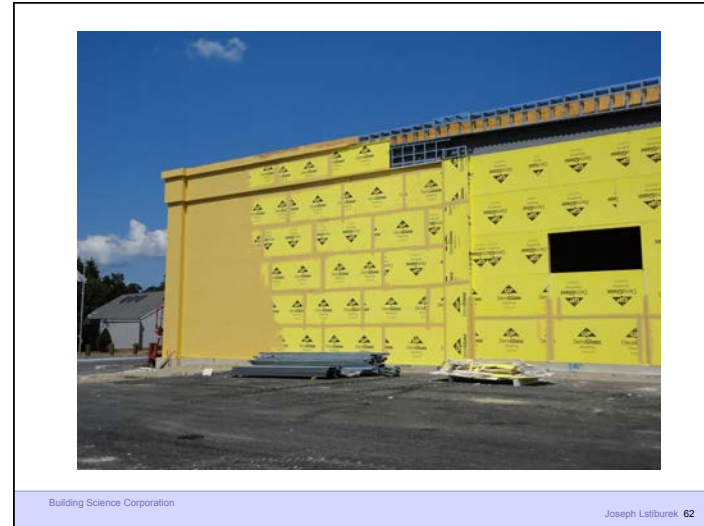



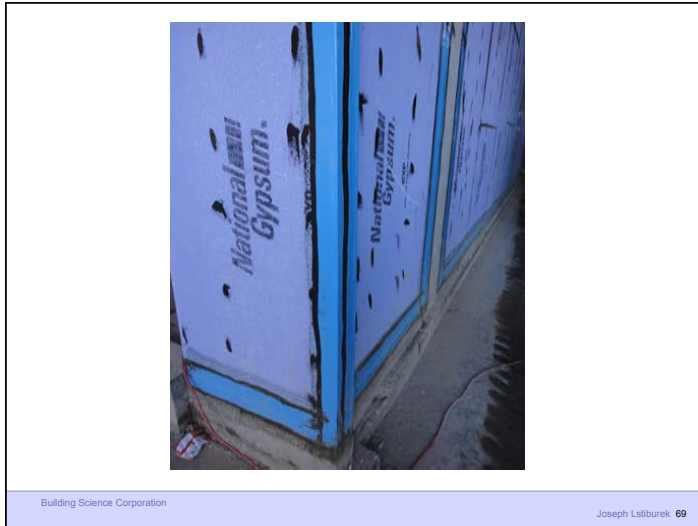



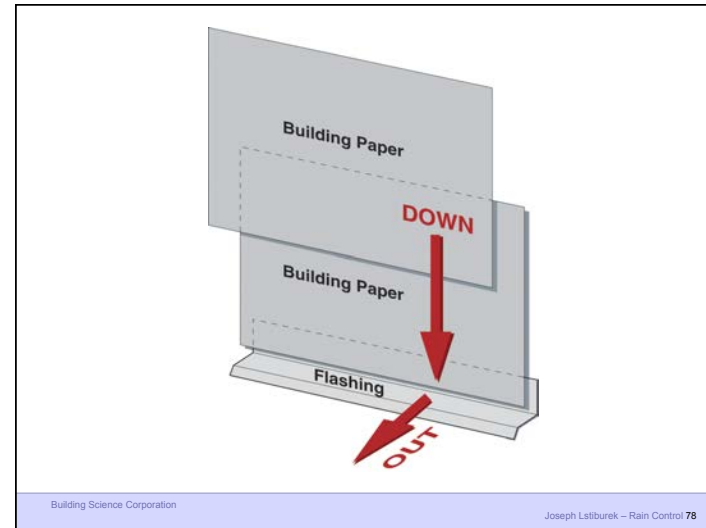
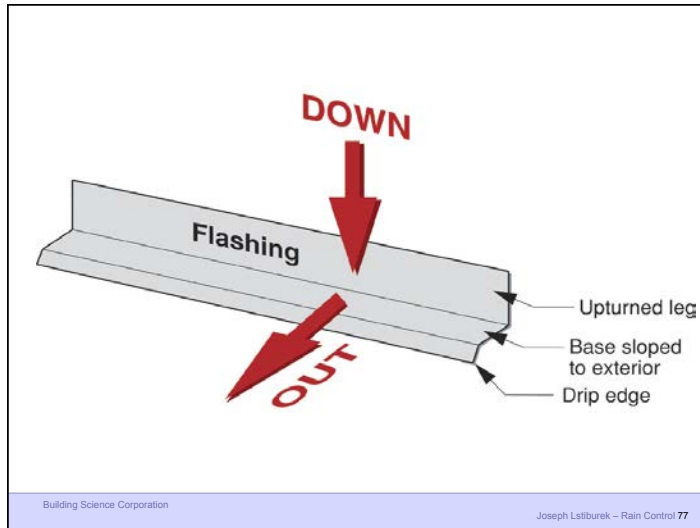

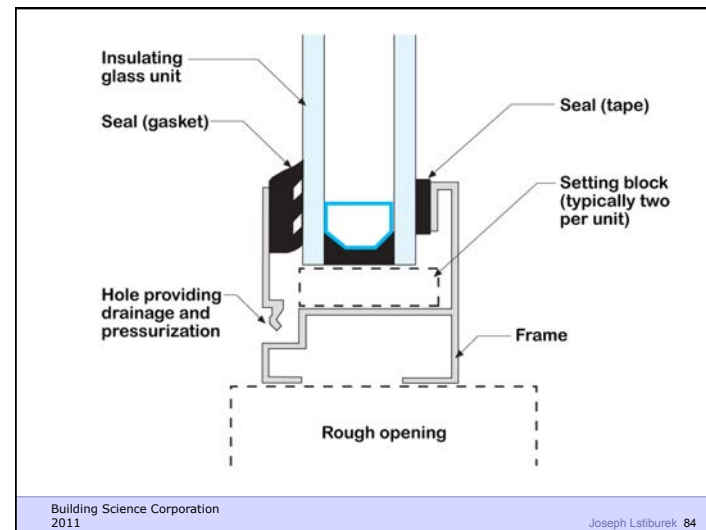
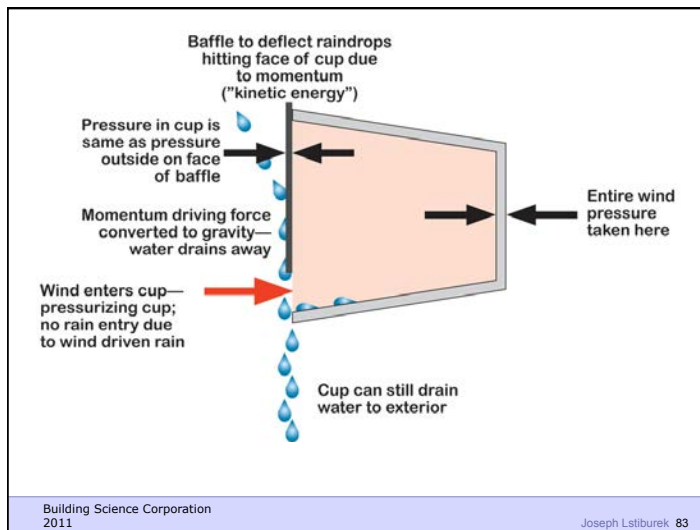
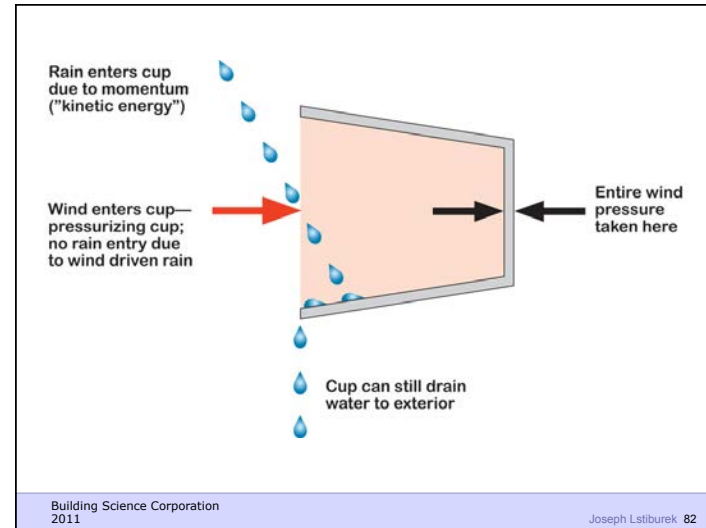
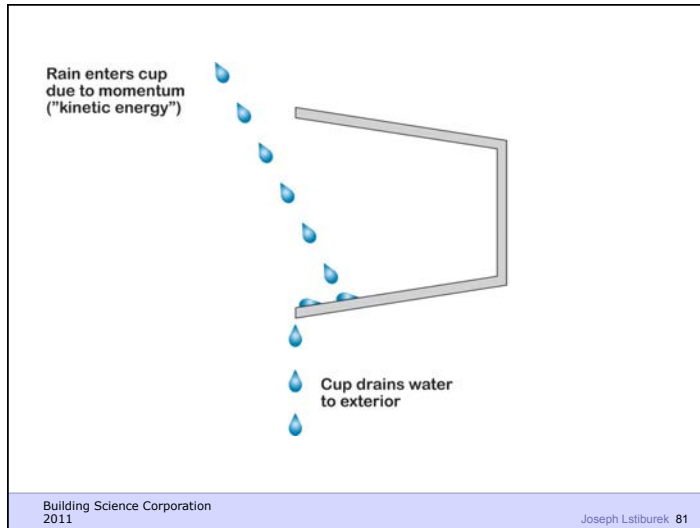

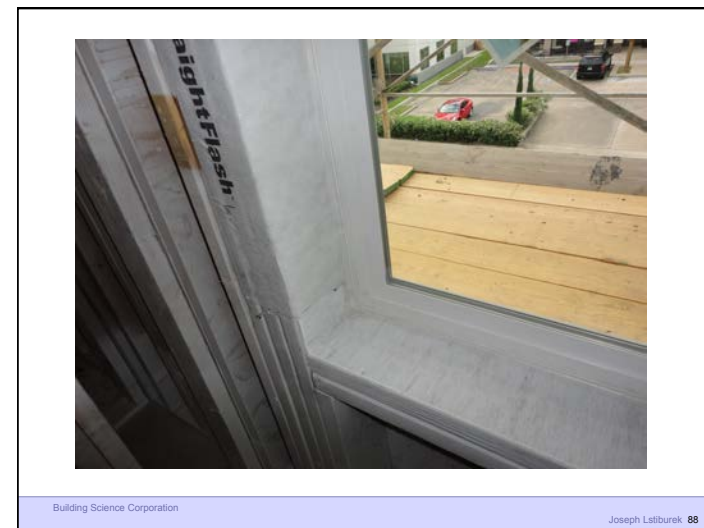
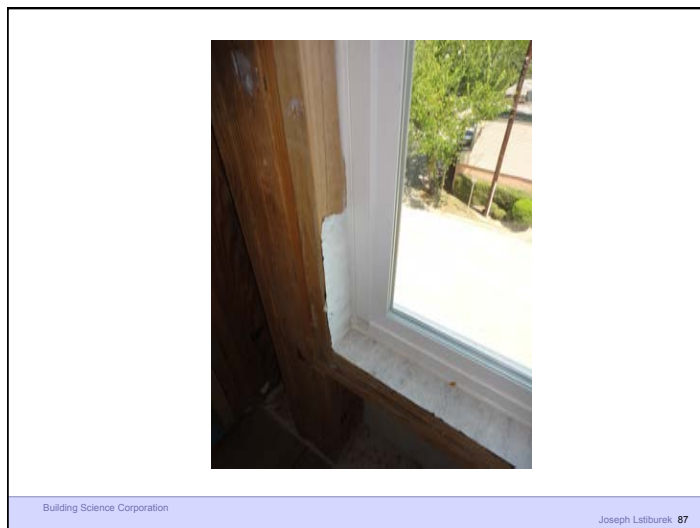
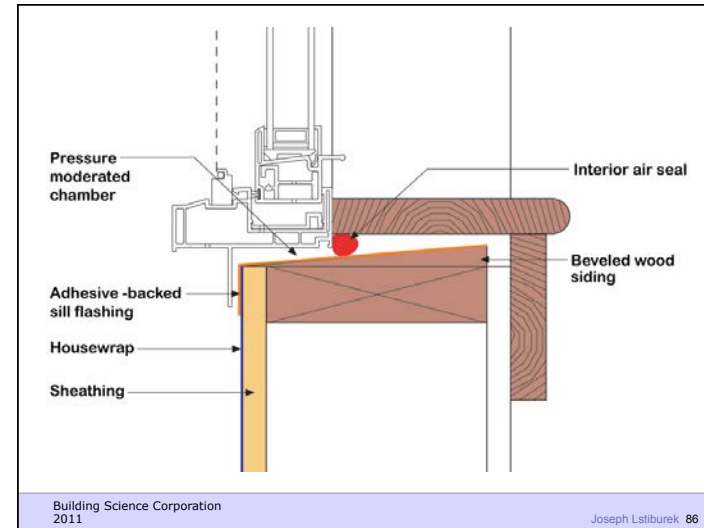
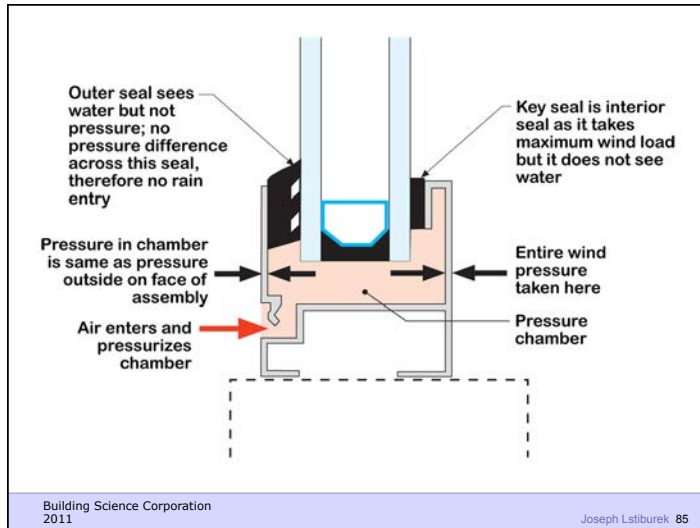

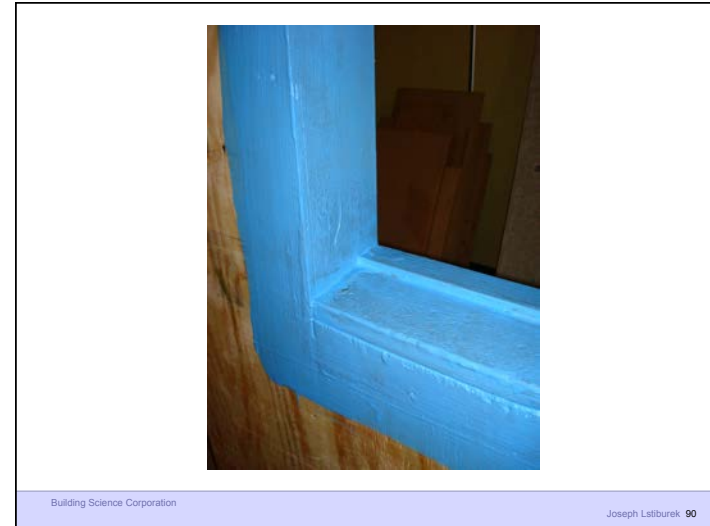

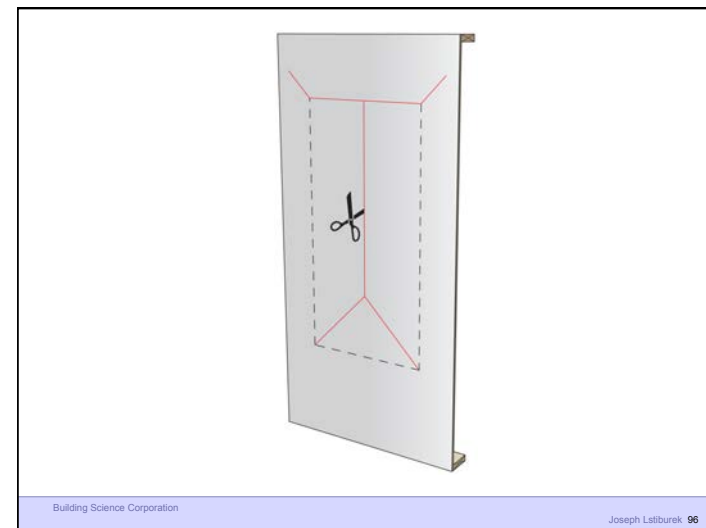
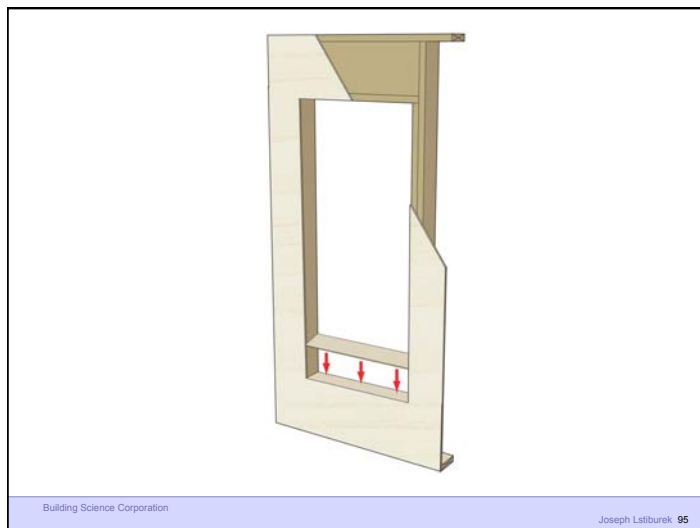
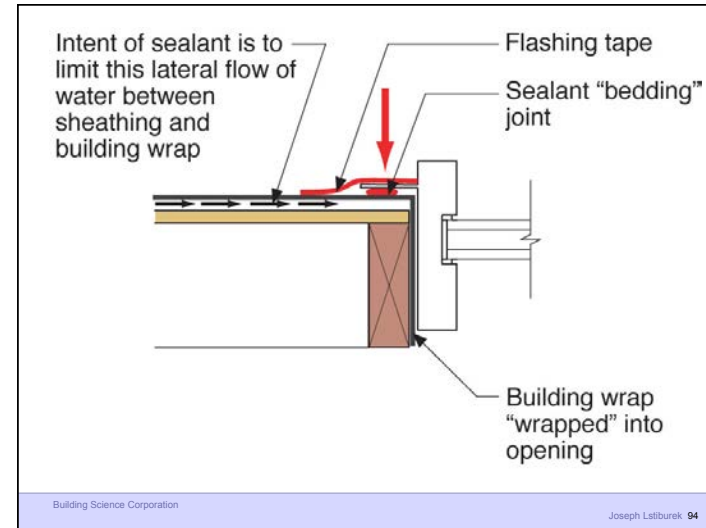

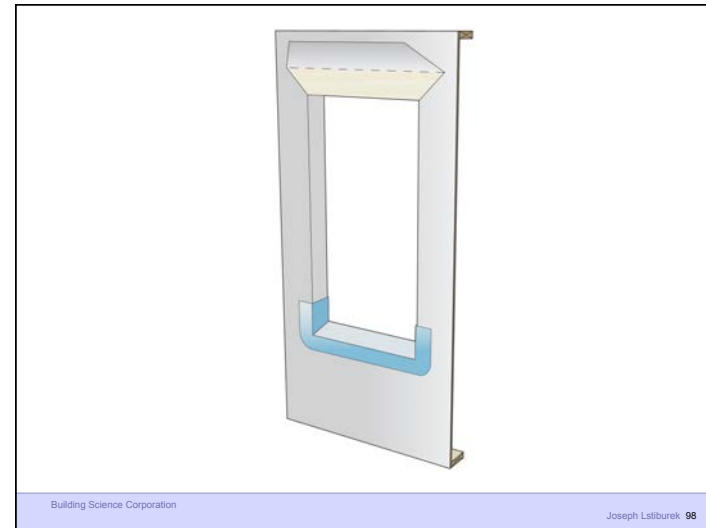
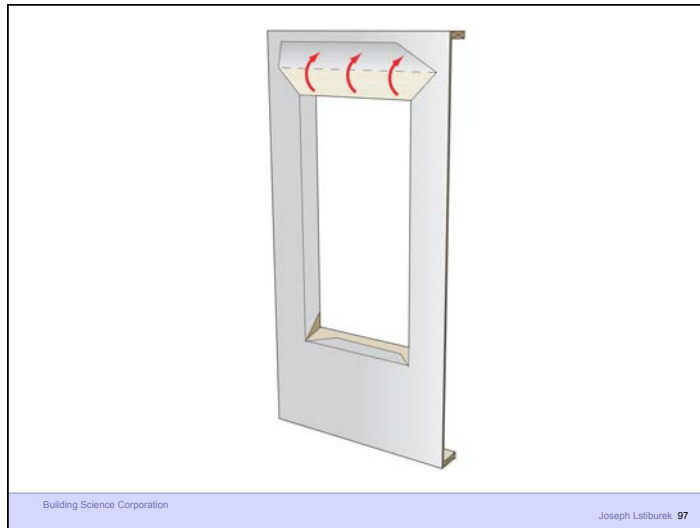

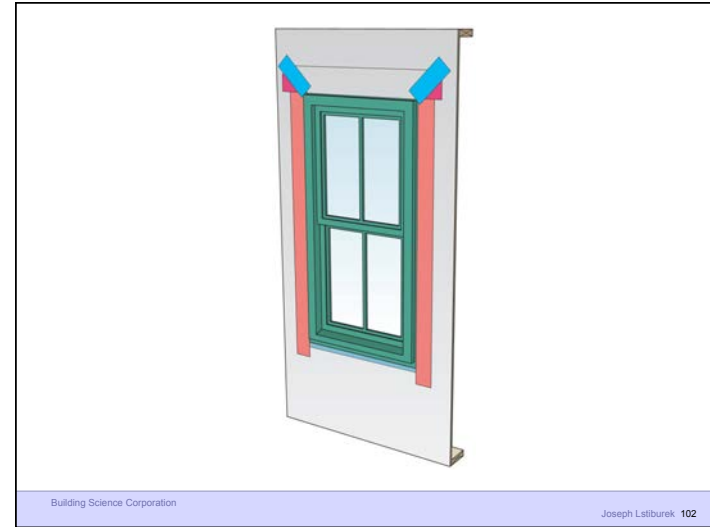
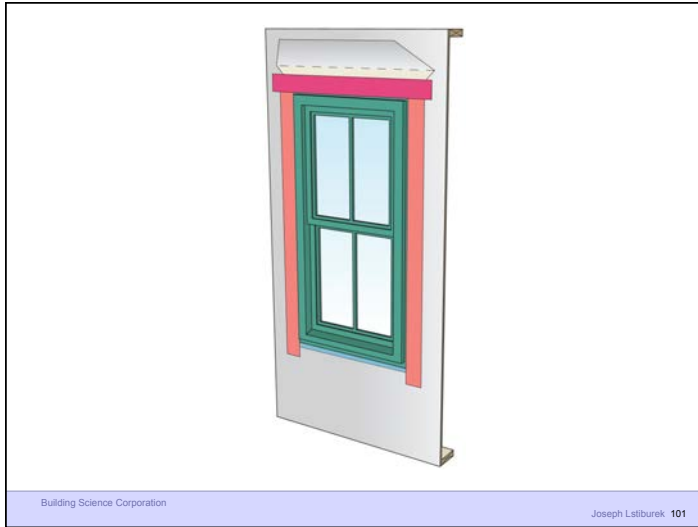

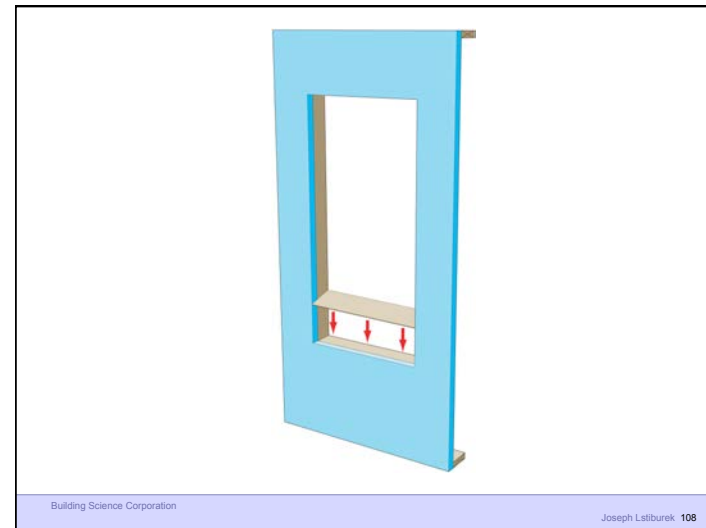
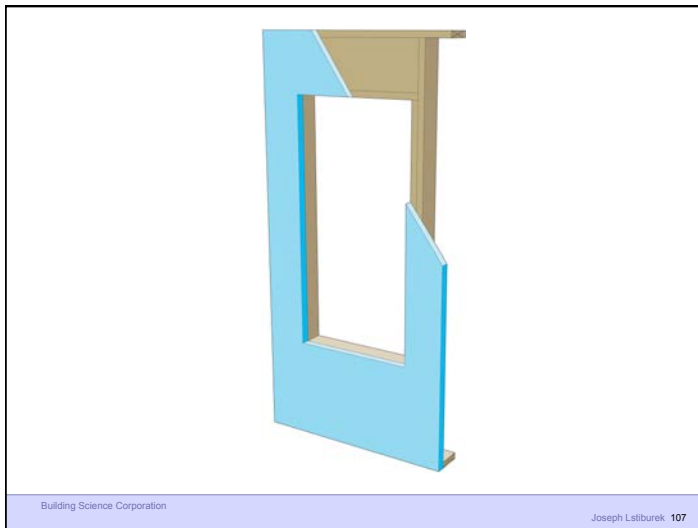
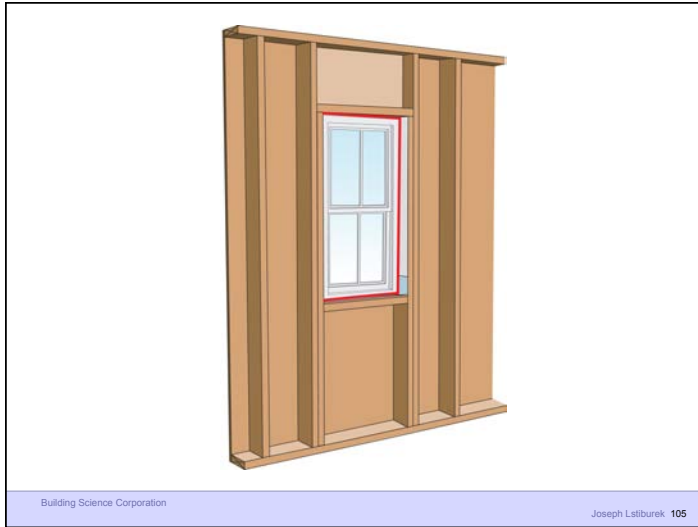

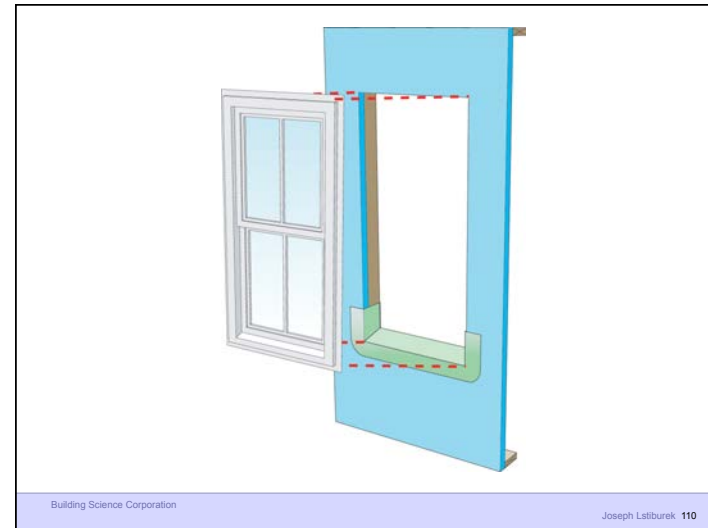
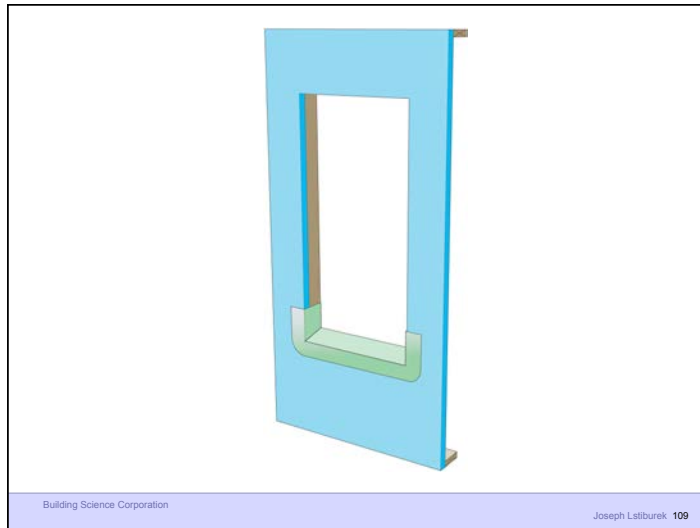

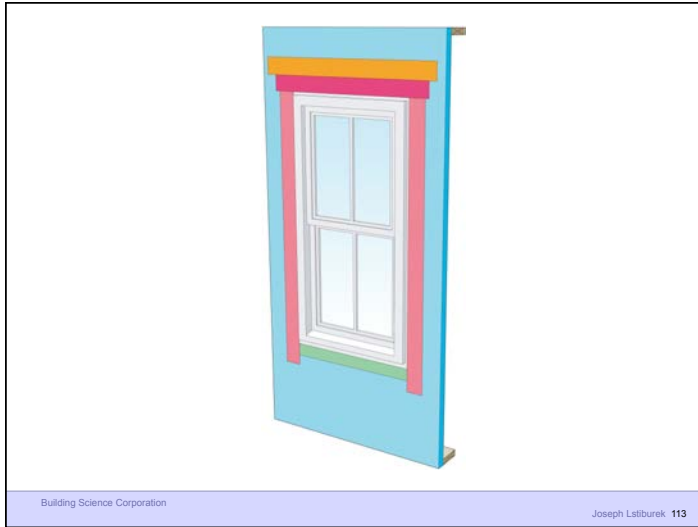

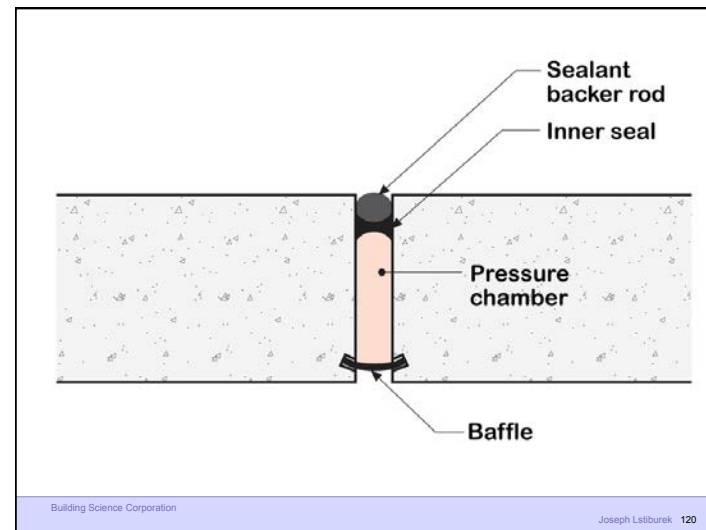
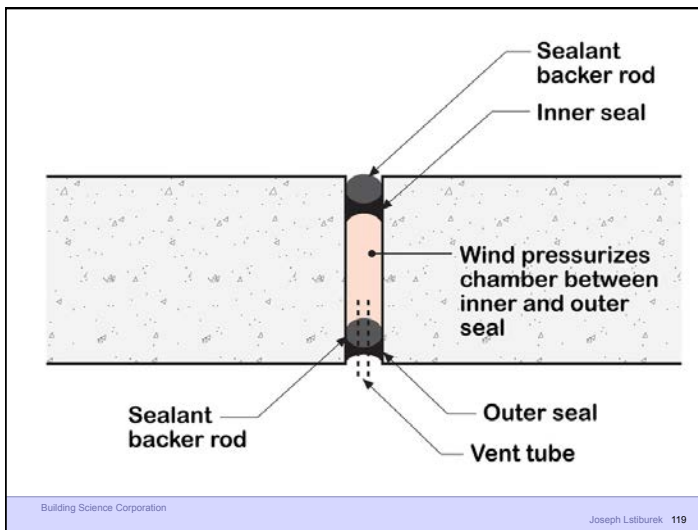
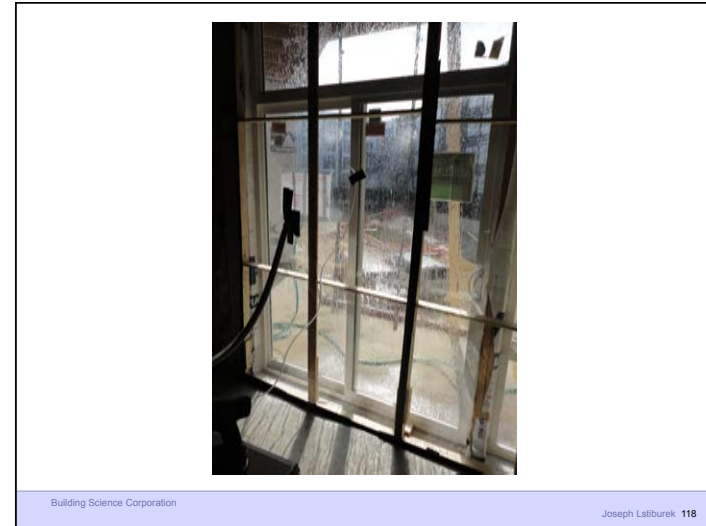

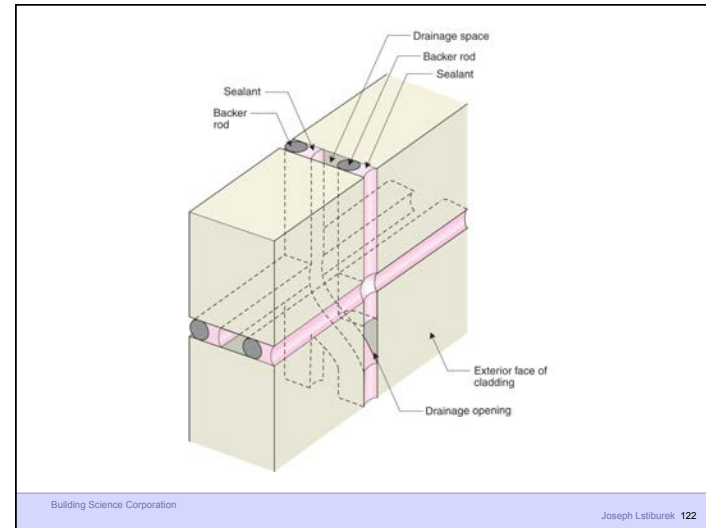
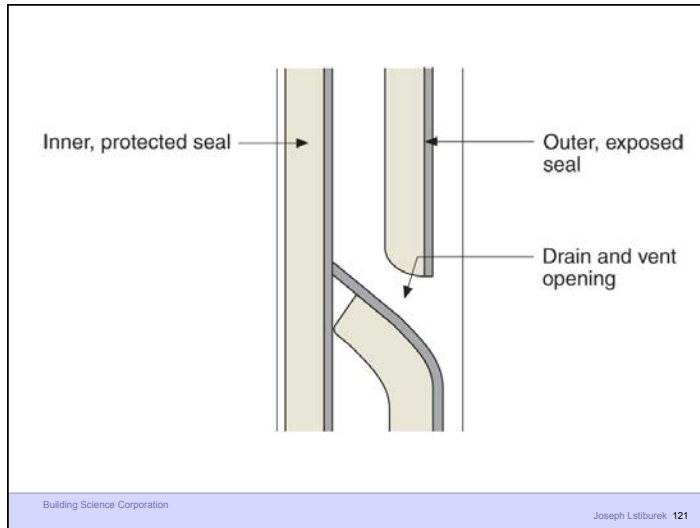

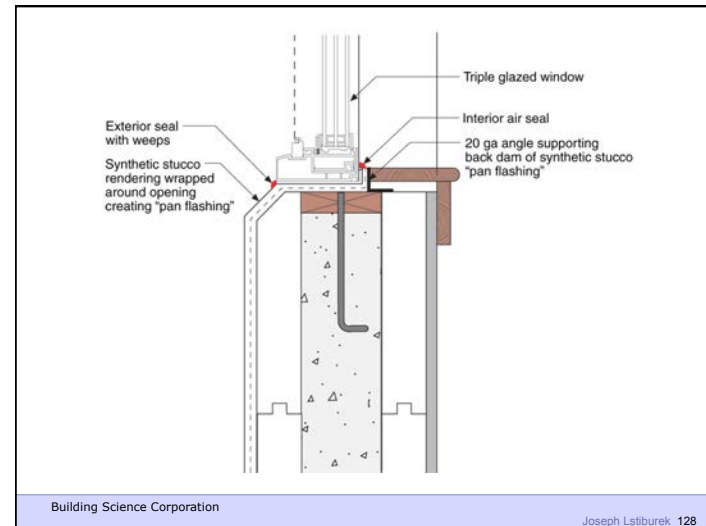

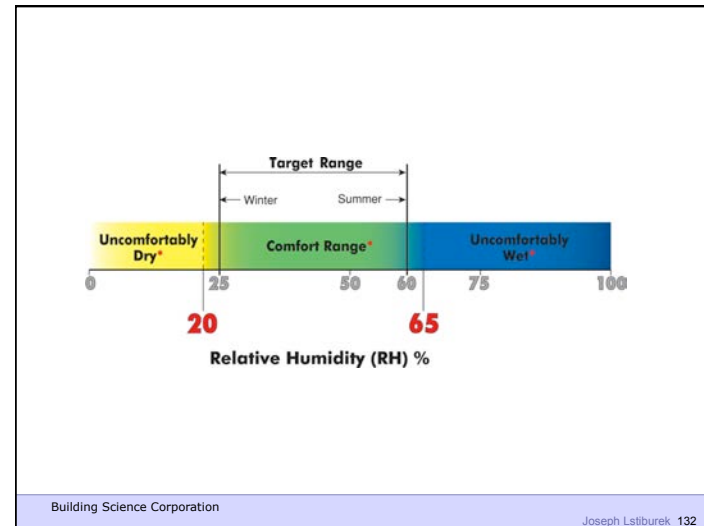
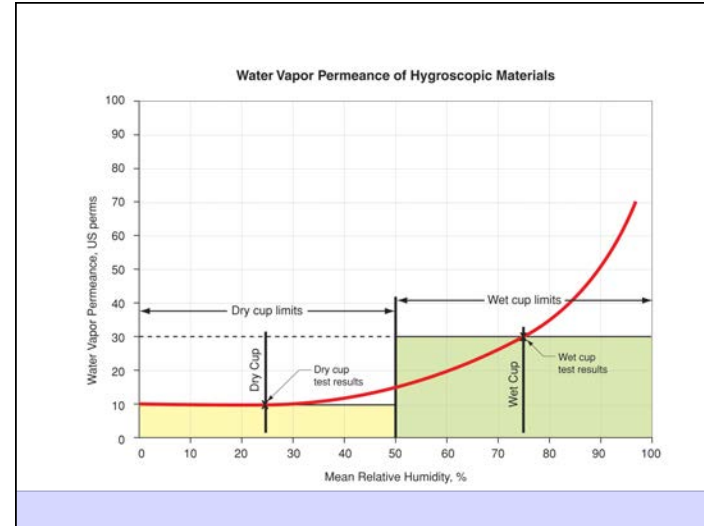
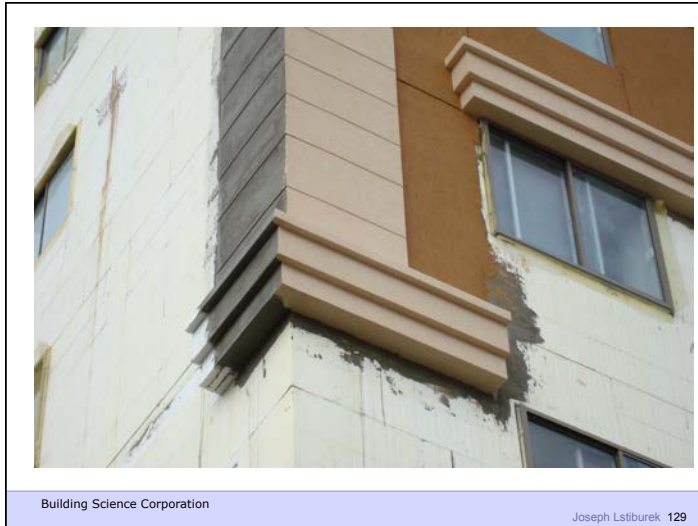

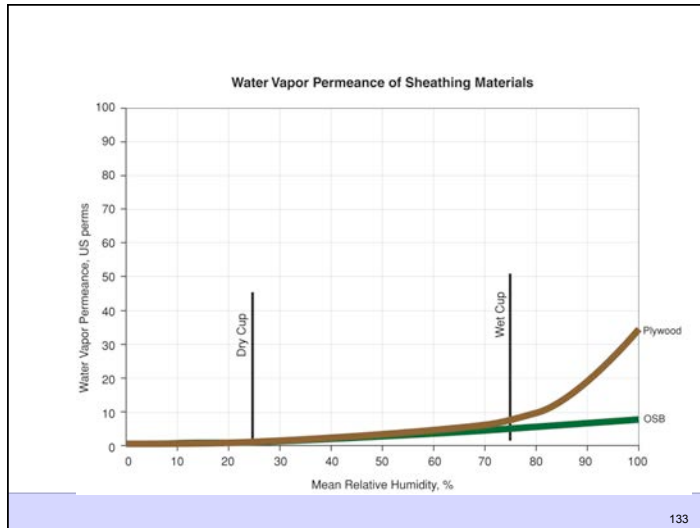

133

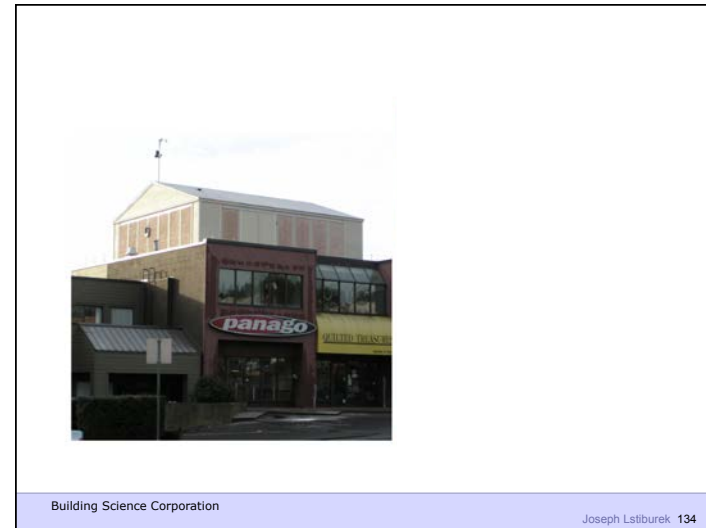

Building Science Corporation

Joseph Lstiburek 134

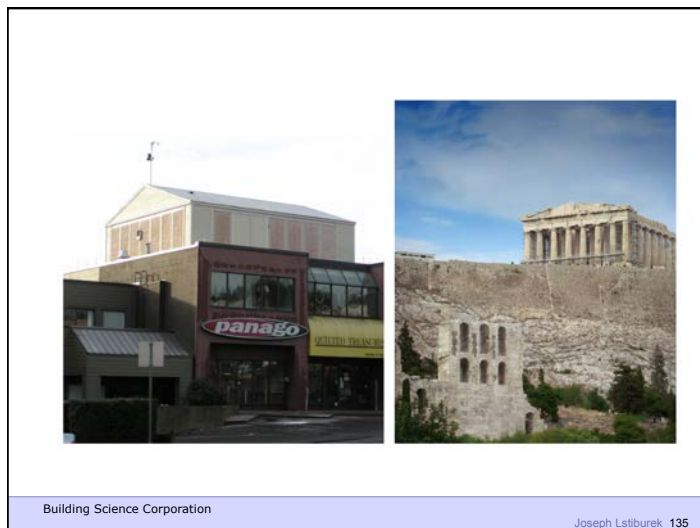

Building Science Corporation

Joseph Lstiburek 135



Building Science Corporation

Joseph Lstiburek 136

